

C3381



Crestchic Loadbanks
WORLDWIDE LOADBANK SPECIALISTS

Load bank Operating Instructions

**Crestchic Ltd.
2nd Avenue
Centrum 100
Burton upon Trent
Staffordshire
United Kingdom
DE14 2WF**

**Tel. +44 (0) 1283 531645
Fax. +44 (0) 1283 510103**

**www.crestchic.co.uk
sales@crestchic.co.uk
hires@crestchic.co.uk**

Reproduction of this document, in part or whole, by any means, electrical, mechanical, optical, chemical, manual or otherwise is prohibited without written permission from Crestchic Limited.

The information contained herein is believed to be accurate as of the date of publication, however, Crestchic Limited will not be liable for any damages, including indirect or consequential, arising from use of the hardware or software described within or reliance upon the accuracy of this documentation. The information contained herein is subject to change without notice.

Revision: A
Date: 16th August 2006



3.3MVA RESISTIVE / REACTIVE LOADBANK

CONTENTS

- 1. GENERAL LOADBANK INFORMATION**
- 2. SAFETY CONSIDERATIONS**
- 3. DESCRIPTION OF A LOADBANK**
- 4. INSTALLATION / OPERATION OF LOADBANK**
- 5. MAINTENANCE**
- 6. TROUBLESHOOTING**
- 7. TERMINOLOGY / CALCULATIONS**
- 8. ECLIPSE AC LOADBANK OPERATING INSTRUCTIONS FOR WINDOWS PC**
- 9. ECLIPSE AC LOADBANK OPERATING INSTRUCTIONS FOR HHT CONTROLLER**
- 10. PARTS LIST**
- 11. DRAWINGS – GENERAL ARRANGEMENT**
- 12. DRAWINGS – WIRING DIAGRAMS**
- 13. PARTS LISTS / DRAWINGS – SUB-ASSEMBLIES**
- 14. TECHNICAL INFORMATION**
- 15. TEST RESULTS**



1. GENERAL LOADBANK INFORMATION

Customer Crestchic (Asia-Pacific) PTE Ltd
Singapore.

Loadbank Serial No. C3381

Equipment 3.3MVA Loadbank
10ft. Container

Loadbank Capacity @ 480V

kVA	kW	PF
3300	2640	0.8
3105	2640	0.85
2933	2640	0.9
2779	2640	0.95
2640	2640	unity

Test Supply 380-480V, 50/60Hz, 3-Phase, 3/4-Wire

Step Resolution 1.67kW / 1.90kVA_r @ 480V

Auxiliary Supply 380-480V, 50/60Hz, 3-Phase, 4-Wire

Control System Micro

Controller HHT / PC

Loadbank Software EclipseC55 Edition 22

PC Software Eclipse V1.80 / Transview V1.56

Dimensions 2991 x 2438 x 2591mm (l, w, h)

Gross Weight 8900kg

Paint Specification White – BS4800 00E55



2. SAFETY

General Safety

1. Injury to the person operating or servicing this equipment is able to occur if any of these **SAFETY** and/or **WARNING** statements are ignored.
2. The user must be fully conversant with this manual and in full understanding of it before operating the loadbank.
3. Personal injury from electrical shock may occur if the power is not isolated before any maintenance measures are undertaken.
4. The loadbank must be operated only by personnel adequately experienced in the operation of the power source(s) being connected to it.
5. The loadbank must only be operated with all of its covers in their correct positions and secured.

Installation

6. For safety purposes upon receiving the loadbank an initial inspection is recommended. In addition to this periodical preventative maintenance and safety inspections are required to ensure the continued safe and reliable operation of the unit.
7. The loadbank must be properly sited, stable and located in a well ventilated area.
8. Connect a ground wire from the Loadbank Earth Stud Terminal to the power supply under test. Size the Earth cable accordingly. The loadbank **must not** be operated without an adequate earth connection.
9. A minimum clearance of 2m (4m recommended) must be allowed from the inlet grille.

Warning **The loadbank produces a hot exhaust gas approximately 120°C above ambient temperature at a distance of 1m from the outlet grilles.**

10. Do not position the loadbank where hot exhaust air is able to re-circulate back through the inlet grille, as this will cause the unit to overheat.
11. All safety devices within the loadbank have been proven reliable as part of the test procedure.
12. Ensure that the load cables are of good condition and suitably rated for the current they will be required to carry from the power source to the loadbank.



13. Route the load cables through the canvas pouch aperture to the connection chamber and securely connect them to the correct loadbank terminals. **Do not** route the cables through the connection chamber door, or leave the door open during test.
14. Observe the correct 3-phase and neutral sequence (if neutral connected) when connecting the loadbank to the power source. Connecting a phase to the neutral **will damage** the loadbank.
15. If more than one loadbank is to be used then the test supply should be connected to each load bank in parallel.
16. Do not operate the Loadbank over the rated voltage or frequency as this may cause failure to the loadbank.
17. Under no circumstances is the Over Temperature Switch to be bypassed. If the loadbank is operated with the temperature switch bypassed the elements will be liable to overheat if any fault condition occurs. In severe cases this will result in the unit catching fire.
18. Air-flow switches are fitted to the fan(s) to detect the fan(s) are running. If an air-flow switch as not activated upon start up, or should open during operation the load will be dropped after a 12 second delay to prevent overheating.
19. Circuit Breakers and/or Fuses are fitted in the loadbank for short circuit and over current protection.
20. Ensure that all covers, inlet/outlet grilles are fixed and all doors are closed before applying power to the loadbank.
21. At the end of a test the load must be set to zero and the loadbank fan(s) left running for a minimum of 5 minutes to cool the resistive elements.
22. Avoid contact with the outlet grille during test and a period of time afterwards as this becomes very hot during operation and may result in serious burns.
23. Do not permit objects to enter or block the air inlet/outlet grilles of the Loadbank. A blockage will cause the Loadbank to overheat. If an object enters the loadbank it will cause damage to the fan(s) and/or resistor elements. If objects enter the loadbank grilles then the unit must be switched off, removed from all sources of electrical supply and then inspected physically and electrically to ensure no damage has occurred.



3. DESCRIPTION OF A LOADBANK

The loadbank is an outdoor, transportable resistive/reactive unit for electrically load testing 380-480V A.C. 50/60Hz 3-phase power supplies with voltage tolerance of 5%.

The function of the loadbank is the dissipation of electrical energy which is transformed into heat by the resistive elements. This unit will produce 2640kW of real power dissipation at 480V full load.

The heat is removed from the loadbank by the fan(s) passing air over the resistive elements. It is essential the inlet and outlet grilles are free from any obstruction otherwise the loadbank will overheat.

Circuit Breakers and/or Fuses are fitted inside the loadbank for short circuit and over current protection.

Do not operate the Loadbank over the rated voltage or frequency as this may cause failure to the loadbank.

External Auxiliary Supply input 380-480V 50/60Hz. If this supply is connected select 'External' of the 'Control Supply' switch and also select the voltage range on the 'Control Voltage' switch of the connected supply. This will supply the cooling fans and the control of the loadbank. 63A 3-phase supply is required.

If no External Auxiliary Supply is connected, the 'Control Supply' switch must be in the 'Internal' position and again select the voltage range on the 'Control Voltage' switch of the connected test supply. If the control of the loadbank is derived from the test supply, should the voltage fall below 340V while under load the cooling fan(s) will stop, resulting in the load to be dropped.

A 230V inlet socket is provided for internal lighting and anti-condensation heating. This circuit should remain live at all times whenever possible, to prevent condensation build-up inside the load module and the micro control chamber. If this is not connected the auxiliary supply is used to prevent condensation in the micro control chamber when switched on.

Load application is controlled from either the Hand Held Terminal (HHT) or a Laptop PC with Eclipse Software installed. For complete Micro (MCS) operating instructions please refer to 'Eclipse AC Loadbank Operating Instructions for Windows PC' or 'Eclipse AC Loadbank Operating Instructions for HHT Controller' enclosed in this manual.



4. INSTALLATION / OPERATION OF LOADBANK

Installation

Upon receiving the loadbank an initial inspection is recommended. In addition to this periodical preventative maintenance and safety inspections are required to ensure the continued safe and reliable operation of the unit.

The loadbank must be properly sited, stable and located in a well ventilated area.

A minimum clearance of 2m (**4m** recommended) must be allowed from the inlet grille. Ensure that no loose material is in the vicinity of the inlet grille (e.g. Paper).

Warning **The loadbank produces a hot exhaust gas approximately 120°C above ambient temperature at a distance of 1m from the outlet grilles.**

Do not position the loadbank where hot exhaust air is able to re-circulate back through the inlet grille, as this will cause the unit to overheat.

When installing two or more loadbanks ensure they are sufficiently spaced from each other, so the hot exhaust from one unit does not feed the air intake of another.

Connect a ground wire from the Loadbank Earth Stud Terminal to the power supply under test. Size the Earth cable accordingly. The loadbank **must not** be operated without an adequate earth connection.

Ensure that the load cables are of good condition and suitably rated for the current they will be required to carry from the power source to the loadbank.

Route the load cables through the canvas pouch aperture to the connection chamber and securely connect them to the correct loadbank terminals. **Do not** route the cables through the connection chamber door, or leave the door open during test.

Securely connect the test load cables to the terminals; observe the correct 3-phase and neutral sequence (if neutral connected) when connecting the loadbank to the power source. Connecting a phase to the neutral **will damage** the loadbank.

Connect the 'External' auxiliary supply if one is to be used. 63A 3-phase supply is required. This is the most suitable option to maintain the control / fan(s) supply if the test supply should fail.

Connect Remote Voltage Sensing supply if one is to be used for instrumentation.

Do not leave the connection chamber door open during operation of the loadbank or test supply live.



All safety devices within the loadbank have been proven reliable as part of the test procedure.

Under no circumstances is the Over Temperature Switch to be bypassed. If the loadbank is operated with the temperature switch bypassed the elements will be liable to overheat if any fault condition occurs. In severe cases this will result in fire.

Circuit Breakers and/or Fuses are fitted in the loadbank for short circuit and over current protection.

Ensure that all covers, inlet/outlet grilles are fixed and all doors are closed before applying power to the loadbank.

Operation

1. Select 'Internal' or 'External' auxiliary supply as required on the control facia. (Internal – control supply taken from the test supply / External – control supply taken from the separate auxiliary supply). Also there is a 'Control Supply' selector switch which must be configured to the appropriate supply that is being fed either Internal or External for the control circuitry.

Eg.1 For 450V test supply – no auxiliary, select the following:-

Internal

440-480V – Control Supply

Eg.2 For 450V test supply – 400V auxiliary supply, select the following:-

External

380V-440V – Control Supply

2. Select 'Loadbank' or 'Terminals' remote voltage sensing as required on the control facia. (Loadbank – voltage sensing taken direct from the test supply / Terminals – voltage sensing taken from separate supply).
 3. Connect the controller unit (HHT or PC) to the control-input socket mounted on the load module facia of the master unit, this is marked 'Control Terminal'. In some cases this may be via an extension reel. Ensure that the cables are in good condition.
 4. If a 'master/slave' configuration is to be used, connect the control cables in cascade i.e. from 'Port B' on the first unit to 'Port A' on the second unit.
 5. It should be noted that for correct operation only one controller should be fitted to a chain of multiple loadbanks, and it is usual for this to be connected to one of the loadbanks at the end of the chain.
 6. If the unit is to be used 'Stand alone', Inter-module communication ports 'Port A' and 'Port B' are not used.
-



7. Ensure that all covers are fixed and all doors are closed.
8. This equipment has been fitted with an 'Emergency Stop', if pressed this will shed all load and stop the movement of the fan(s). Ensure that the fault / hazard as been cleared before resetting the Emergency Stop.

Note: - The 230V supply for the internal lighting and heating, if connected is not affected by the Emergency Stop.

Warning: - The Emergency Stop does not isolate the Test Supply or the Auxiliary Supply; this must be done at source.

9. The equipment is now ready for use.
10. Switch on the Auxiliary Supply if one is to be used.
11. Switch on the test supply.
12. For complete Micro (MCS) operating instructions please refer to 'Eclipse AC Loadbank Operating Instructions for Windows PC' or 'Eclipse AC Loadbank Operating Instructions for HHT Controller' enclosed in this manual.
13. The load module is fitted with automatic correction of phase rotation on the fan supplies. Once the fan(s) have started check that the airflow is normal and in the direction from the fan(s) and across the elements.
14. If a cooling fault condition occurs, by loss of the airflow due to the inlet grilles being blocked or fan failure, which is detected by airflow switches AF1 – AF6, or if the temperature sensors inside the load module exceed 90°C the load will automatically lock out.
15. If the equipment being tested fails, and this is providing the power for the control system, then the cooling fans will stop. Whilst this is not dangerous on an occasional basis, it is to be avoided if there is the possibility of the power source under test repeatedly shutting down when close to full load. In these circumstances an external auxiliary supply should be used for the control system, to keep the fans running and prevent unnecessary thermal stressing of the loadbank resistive elements.
16. Avoid contact with the outlet grille during test and a period of time afterwards as this becomes very hot during operation and may result in serious burns.
17. Do not permit objects to enter or block the air inlet/outlet grilles of the Loadbank. A blockage will cause the Loadbank to overheat. If an object enters the loadbank it will cause damage to the fan(s) and/or resistor elements. If objects enter the loadbank grilles then the unit must be switched off, removed from all sources of electrical supply, allowed to cool fully, and then inspected both physically and electrically to ensure no damage has occurred.



Crestchic Loadbanks

WORLDWIDE LOADBANK SPECIALISTS

18. At the end of a test the load must be set to zero and the loadbank fan(s) left running for a minimum of 5 minutes to cool the resistive elements.
19. The number of starts per hour of the fan(s) should be limited to ten to avoid overheating.



5. MAINTENANCE

Crestchic Load Banks are virtually 'maintenance free' however we do recommend that the units are checked once a year for tightness of all electrical and mechanical connections, and also the load contactors should be checked for wear.

General maintenance must be carried out with the test and auxiliary power isolated from the loadbank.

For fault finding, when a supply is required, then only the auxiliary supply should be connected. Maintenance work should only be done by qualified personnel, fully aware of the danger involved.

WARNING: -PERSONAL INJURY FROM ELECTRICAL SHOCK MAY RESULT IF THE POWER IS NOT ISOLATED BEFORE SERVICING. MAINTENANCE WORK MUST BE CARRIED OUT BY QUALIFIED PERSONNEL.

The resistive elements are long life maintenance free items, if an element was to "blow" or become damaged for any reason, obviously this would affect the loading of the electrical supply under test. The element cannot be repaired and a replacement element would have to be installed, this can be obtained from Crestchic Ltd. (please specify kW rating and voltage engraved on the element).

Fan units are fitted with 'sealed for life' bearings lubricated with wide temperature range grease and require no maintenance.

All panel/door seals must be inspected every 6-months to ensure they make a good seal to prevent water or any foreign matter entering the enclosure.

Door hinges and fasteners must be lubricated every 6-months, and also castor mounted units should have the castors lubricated.

Reactor fan filters to be inspected **monthly** or after use in a dirty environment to ensure good air flow into the container. This is to prevent the interior of the container from overheating.

Replacing Elements

Disconnect the cables or coppers connected to the faulty element termination points. The elements are fitted with two glands at the termination ends which securely hold the element in position, some Load Banks are fitted with element support hooks and others fitted with 'toast racks' to support the other end. Remove the nuts on the glands to free the element. Remove one of the grilles in the element chamber (the nearest to the element) and slide the element out.



Torque Settings

To ensure correct tightness of all electrical POWER connections, the torque settings shown in **Table 1** below must be used.

Location	Connections	Steel Fixings		Brass Fixings	
		Torque (N.m)	Torque (lbf.in)	Torque (N.m)	Torque (lbf.in)
Busbars	M6 Copper	7.2	63.7		
	M8 Copper	17	150.5		
	M10 Copper	28	247.8		
	M12 Copper	45	398.3	33	292.1
	M16 Copper	91	805.4	74	654.9
Elements	4BA Elements	1.2	10.6		
	2BA Elements	1.75	15.5		
Fuses	Bolt-on fuses	17	150.5		
	32A Fuse Holder	2	17.7		
	63A Fuse Holder	3	26.6		
	100A Fuse Holder	3.5	31.0		
	125A Fuse Holder	4	35.4		
Siemens Contactors	Contactors 10231-10261	2.0-2.5	18.0-22.0		
	Contactors 10341-10361	3.0-4.5	27.0-40.0		
	Contactors 10441-10461	4.0-6.0	36.0-53.0		
	Contactors 10541-10566	10.0-14.0	90.0-124.0		
	Contactors 10646-10666	14.0-24.0	124.0-210.0		
	Contactors 10756-10766	14.0-24.0	124.0-210.0		
Telemecanique Contactors	Contactors D12	1.2	10.6		
	Contactors D18	1.7	15.0		
	Contactors D25	1.85	16.4		
	Contactors D32	2.5	22.1		
	Contactors D40	5	44.3		
	Contactors D50	5	44.3		
	Contactors D65	5	44.3		
	Contactors D80	9	79.7		
	Contactors D95	9	79.7		
	Contactors D115	14	123.9		
	Contactors F150	14	123.9		
	Contactors F185	17	150.5		
	Contactors F225 to F500	35	309.9		

Table 1 – Torque Settings



6. TROUBLESHOOTING

Maintenance should be carried out with the main power isolated from the loadbank, and only done by qualified service engineers/technicians. Auxiliary power supply may be required to carry out necessary checks.

Problem	Check	Action
Loadbank control supply not on	Control circuit breakers not closed	Check and close circuit breaker – Repeated tripping of the circuit breaker must be investigated
	Internal/Off/External switch set to the Off position	Set the switch to the Internal or External position as required
	Emergency stop actuated	Release the emergency stop (pull)
Fan(s) not running/Fan contactor(s) not energised	Fan motor overload tripped	Reset fan motor overload. Repeated tripping must be investigated further.
	Loose connection	Check and tighten as necessary.
	Fuse to Logo Module FT1 blown	Check and replace.
	PSR or PSF Supply problem – refer to Table 3 below.	Refer to Table 3 .
	Fan(s) failure	Check and replace if necessary.
No load applied	Over temperature sensor activated	Check loadbank cooling/airflow.
	Load circuit breaker(s) not closed	Close circuit breaker.
	Air-flow paddle not energised	Check air-flow paddle switch or air flow
	Loose connection	Check and tighten as necessary.
Load step not energised	Fuse(s) blown.	Check and replace. Repeated fuse blowing must be investigated further
	Contactor failure	Check and replace if required.
	Driver board slave relay failure	Check and replace as required.
	Loose connection	Check and tighten as necessary.



Problem	Check	Action
Load step not providing the rated load	Applied voltage is de-rated	Check and correct if necessary
	Fuse(s) blown.	Check and replace. Repeated fuse blowing must be investigated further
	Contactors not fully energised	Check and replace contactor if necessary
	Load step resistor element(s) are open-circuit.	Check and replace as required
Contactor "chattering"	Connection to contactor coil loose	Check and tighten as necessary
	Control circuit voltage too low	Check control voltage and auxiliary supply and or test supply
	Contacts/core dirty or corroded	Check and replace contactor if necessary
No communication response	Check all control leads	Check connection security/lead integrity
	Check all ribbon cable connections	Check connection security/lead integrity
	Check Systems Board (Fuse/Transformer)	Check and replace as required
Loadbank error messages	Error message on controller screen	Refer to the summary of loadbank error messages in the attached Eclipse manual

Table 2 – Troubleshooting

Supply Condition	PSR		PSF		Action
	Green LED	Red LED	Green LED	Red LED	
Normal	On	Off	On	Flashing	No action required
	On	Flashing	On	Off	
Under Voltage Condition or phase missing	On	On	On	On	Correct supply voltage, use auxiliary supply or increase cable sizes
PSR Failure	Off	Off	On	Off	Check and replace PSR
PSF Failure	On	Off	Off	Off	Check and replace PSF
No Supply	Off	Off	Off	Off	Check supply at CB64

Table 3 – Phase Failure Relay/Supply Problems

7. TERMINOLOGY / CALCULATIONS

Apparent Power	MVA / kVA / VA
Real/Actual Power	MW / kW / W
Reactive Power	MVAr / kVAr / VAR
Power Factor	p.f. = $\cos\phi$
Unity Power Factor	kW = kVA

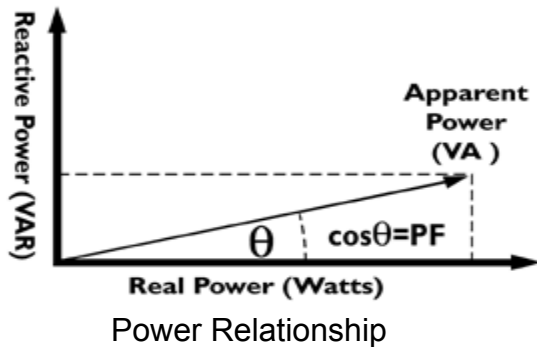

Ohm's Law $I = V / R$ (A) $V = I \times R$ (V) $R = V / I$ (Ω)

Loadbank Capacity at other voltages:-

Rated Power Capacity of loadbank x (Applied Voltage / Design Voltage)² = Actual Power

e.g. $4800 \times (415 / 480)^2 = 3588\text{kW}$

Power Calculations:-

e.g. 2.0MVA @ 0.9p.f. 480V

Real Power = kVA x pf = kW $2000 \times 0.9 = 1800\text{kW}$

Reactive Power = $\sqrt{((\text{kVA}^2) - (\text{kW}^2))}$ = kVAr $\sqrt{((2000^2) - (1800^2))} = 872\text{kVAr}$

Apparent Power = $\sqrt{((\text{kW}^2) + (\text{kVAr}^2))}$ = kVA $\sqrt{((1800^2) + (872^2))} = 2000\text{kVA}$

Real Power = $\sqrt{((\text{kVA}^2) - (\text{kVAr}^2))}$ = kW $\sqrt{((2000^2) - (872^2))} = 1800\text{kW}$

3Ø Current = kW / ($\sqrt{3} \times V$) $1800 / (1.732 \times 480) = 2165\text{A (kW)}$

3Ø Current = kW / ($\sqrt{3} \times V \times \text{pf}$) $1800 / (1.732 \times 480 \times 0.9) = 2405\text{A (kVA)}$

3Ø Current = $\sqrt{((\text{A-kW}^2) + (\text{A-kVAr}^2))}$ = A $\sqrt{((2165^2) + (1048^2))} = 2405\text{A}$

kVA = $\sqrt{3} \times V \times I$ $1.732 \times 480 \times 2405 = 2000\text{kVA}$



Noise Calculation:-

If you have identical noise sources and you require the total noise level the formula is as follows: -

10xlog (No. of sources) added to the source level

e.g. 4.5MVA with 85dBA @ 3m approx.

2 x 4.5MVA each with 85dBA

$$10 \times \log 2 = 3 \qquad 3 + 85 = 88\text{dBA @ } 3\text{m}$$

Noise level reduction: - Each time the distance is doubled reduce dBA reading by 6.

$$\text{dBA @ } 6\text{m} = 85 - 6 = 79\text{dBA}$$

$$\text{dBA @ } 12\text{m} = 85 - 6 - 6 = 73\text{dBA}$$

Temperature Calculation:-

$$^{\circ}\text{C} = (^{\circ}\text{F} - 32) / 1.8 \qquad ^{\circ}\text{F} = (1.8 \times ^{\circ}\text{C}) + 32$$

Metric Conversions:-

$$1 \text{ inch} = 25.4 \text{ mm (2.54 cm)} \qquad 1 \text{ cm} = 0.3937 \text{ inch}$$

$$1 \text{ lb} = 0.4536 \text{ kg} \qquad 1 \text{ kg} = 2.2046 \text{ lbs}$$



Crestchic Loadbanks
WORLDWIDE LOADBANK SPECIALISTS

8. ECLIPSE AC LOADBANK OPERATING INSTRUCTIONS FOR WINDOWS PC



Crestchic Loadbanks

WORLDWIDE LOADBANK SPECIALISTS

Eclipse

AC Loadbank Operating

Instructions for Windows

PC

Crestchic Limited
2nd Avenue
Centrum 100
Burton upon Trent
Staffordshire
United Kingdom
DE14 2WF

Tel. +44 (0) 1283 531645

Fax. +44 (0) 1283 510103

Reproduction of this document, in part or whole, by any means, electrical, mechanical, optical, chemical, manual or otherwise is prohibited without written permission from Crestchic Limited.

This document reflects Release 1.60 or later of the Eclipse software. The information contained herein is believed to be accurate as of the date of publication, however, Crestchic Limited will not be liable for any damages, including indirect or consequential, arising from use of the hardware or software described within or reliance upon the accuracy of this documentation. The information contained herein is subject to change without notice.

Revision: B
Date: 30th August 2004
Author: R. Warwick

Contents

	<u>Section</u>	<u>Page</u>
1.0	Introduction.....	4
2.0	Operator Interface.....	5
3.0	Start Up Sequence.....	6
4.0	Instrumentation Display.....	10
4.1	Digital Instrumentation.....	10
4.2	Analogue Instrumentation.....	12
5.0	Manual Loads.....	14
5.1	Load Preparation.....	14
5.2	Load Application and Control.....	15
6.0	Load Calculation.....	17
7.0	Load Adjustment and Trimming.....	18
7.1	Load Adjustment.....	18
7.2	Load Trimming.....	19
7.3	Learned Loads.....	21
7.4	Summary.....	21
8.0	Search Mode.....	22
8.1	Stored Nodes.....	23
8.2	Applying a Stored Node.....	24
9.0	Preset Loads.....	25
9.1	Overview.....	25
9.2	Defining the M-Load.....	26
9.3	Programming Presets.....	26
10.0	Automatic Load Profiles.....	29
10.1	Creating a Load Profile.....	29
10.2	Writing a Load Profile to Disk.....	31
10.3	Reading a Load Profile from Disk.....	31
10.4	Running an Automatic Load Profile.....	32
11.0	Transient Response.....	35
11.1	Overview.....	35
11.2	Download of Last Transient.....	36
11.3	Transient Menu Options.....	36
11.4	Transient Configuration.....	38

12.0	Configuration Options	39
12.1	Test Supply Details	39
12.2	Results Report Configuration	40
12.3	Loadbank Time	42
12.4	User Pass-code	42
12.5	Communications Port Selection.....	43
12.6	Report Auto Deletion.....	43
13.0	Loadbank Shutdown	44
14.0	Miscellaneous Options.....	45
14.1	Toolbar and Status bar Visibility	45
14.2	Loadbank Statistics	45
14.3	Transducer Values	46
14.4	System Event Log.....	46
14.5	Communications Errors	47
Appendix A	Summary of Menu Options	48
A.1	Command Menu	48
A.2	View Menu	48
A.3	Presets Menu	49
A.4	Transient Menu	50
A.5	Configuration Menu	50
A.6	Help Menu.....	50
Appendix B	PC File Information	51
B.1	Output to a PC	51
B.2	Uploading from a PC.....	52
Appendix C	Quick Start Guide	55
C.1	Setting Up.....	55
C.2	Start Up	56
C.3	Manual Loads.....	57
C.4	Search Mode.....	60
C.5	Automatic Load Profile.....	60
C.6	Configuration Options.....	61
C.7	Shutdown Loadbanks	64
Appendix D	Summary of On-Load Error Messages.....	65
Appendix E	Glossary	67

1.0 Introduction

This document describes the operation of *Crestchic* Loadbanks using the computerised Eclipse AC Load Control System with a PC as the control terminal. **These are general instructions and some of the facilities and options described will depend upon the size, specification and operating range of loadbank being used.**

The computer control system is split into two parts. Firstly there is a powerful microprocessor board situated in the loadbank enclosure. This processor is responsible for the actual calculation and control of the applied load, and the monitoring of the loadbank operating conditions.

The second part of the control system is an electronic controller unit that can be sited at a distance from the loadbank - for example, in the control room of the equipment under test. This controller can be either a custom designed *Crestchic* hand-held control terminal, the HHT100, or a laptop personal computer (PC) running *Microsoft* Windows. The controller is used to provide the operator interface, allowing the required load steps to be set-up and applied and then displaying instrumentation data whilst on-load.

For several reasons it is recommended that a PC be used as the loadbank controller whenever possible. Firstly, because the Eclipse software runs under the Windows operating system it is able to utilise the standard control features familiar to almost everyone who has used a PC. This greatly reduces the learning curve encountered when using the software for the first time as well as making the loadbank operation easy and intuitive. Secondly the Eclipse software fully exploits the display and storage capabilities of a PC providing enhanced facilities and more loadbank functionality than available when using the HHT100 controller.

The Eclipse software can also be supplied on CD-ROM to allow customers to use their own Windows PC to control the loadbank. This software will run under Windows 98/ME/XP and Windows NT/2000/XP-Pro.

It has been attempted to define and explain new terms as they are introduced in the text. However, this has not always been possible. Therefore a glossary of terms is appended at the end of this document for reference purposes.

2.0 Operator Interface

The Eclipse software that runs on a PC is a fully featured Windows application. As such it makes use of all the standard operator interface controls available in this environment. These include drop-down menus, list-boxes, slider controls and toolbar shortcuts.

Together with the point-and-click Windows interface these features combine to provide a user-friendly and intuitive system for loadbank control that will be familiar to most computer users and lets new operators quickly become accustomed to controlling the loadbank in this manner.

For more information on using the standard Windows interface the operator should consult the *Microsoft* documentation provided with their PC.

3.0 Start Up Sequence

When using a PC as the control terminal this should be switched on first, together with any printer that is being used. The PC will go through its start-up procedure and after about 30 seconds will reach a point where the Windows desktop is displayed. To start the loadbank control program double-click on the Eclipse icon to launch the application.

The PC will display the screen shown below and is now ready for the loadbank to be powered up and establish contact.

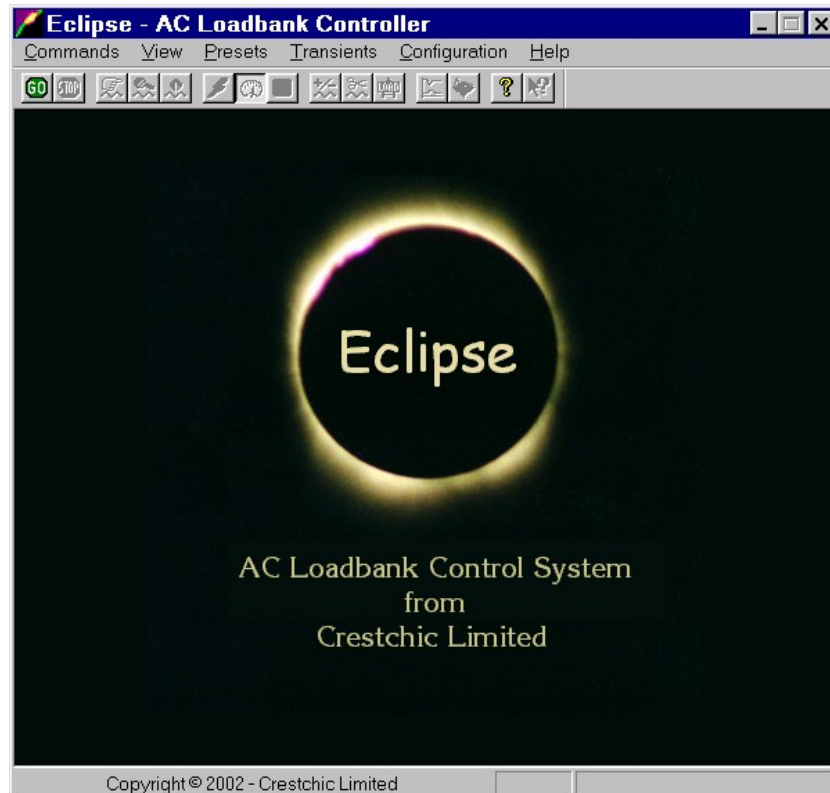

The loadbank(s) may now be switched on. Before doing so ensure the emergency stop buttons are deactivated on all the modules and if a signal distribution pod is being used check its Load Dump switch is in the normal position. Power-up each loadbank by moving the Control Supply selector switch from the OFF/RESET position.

Obviously, for a loadbank control system to function when it is being powered internally from the test supply that power source must be providing voltage to the bus bars at this point. Slave loadbank(s) should be powered-up first followed by the master loadbank.

To commence the loadbank start-up sequence select the Start Loadbank option from the Command menu or simply press the **GO** button on the application toolbar.

When the start-up sequence is initiated the loadbank calibration data is first read into the PC. Once this is done the start-up sequence automatically moves on to the next phase which is to instruct the master loadbank to determine the total load capacity of all the slave loadbanks connected to form the system.

Once the size of the configured load has been determined the results are displayed on the screen as reproduced below.

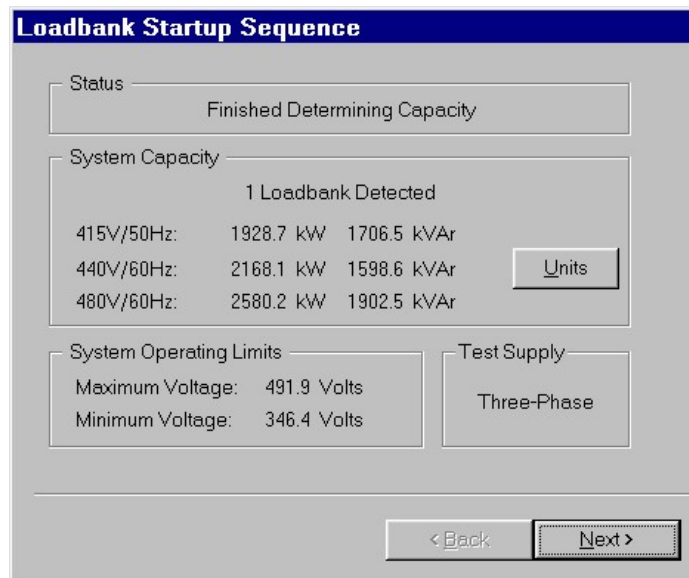

The nominal capacity figures should be checked to ensure the loadbank is capable of providing the load required to fully test the power source. By pressing the Units button the loadbank capacity can be displayed in different units.

This screen also gives details of the operating mode of the loadbank, single-phase or three-phase, and the voltage range that the loadbank is designed to be used within. If an attempt is made to use the loadbank to test a supply that is outside of these limits then an error message will be displayed and any load applied at the time will be shed.

To move to the next phase of the start-up sequence press the Next button. The screen gives details of the generator to be tested. The values displayed are the nominal values for the generator.

The generator parameters entered by the operator are stored in non-volatile memory in the loadbank computer and are displayed every time the loadbank is started. The generator specification may be edited at this point should a different generator be being tested from when the loadbank was last used. Pressing the Edit button allows these values to be modified.

It is important that the generator is specified correctly and the maximum tolerance on the nominal full load output is given. It is these parameters that the loadbank computer uses to ensure that excessive loads are not applied to the generator. More information on editing the Generator Specification is given in the Configuration Menu section of this manual.

The Generator Specification screen is reproduced below. By pressing the Units button repeatedly at this point the load can be displayed in terms of kVA, Amps and kW.

The screenshot shows a software window titled "Loadbank Startup Sequence". It contains two main sections: "Loadbank Inputs" and "Power Source Ratings".

Loadbank Inputs	
Nominal Ph-Ph Voltage:	415.0 Volts
Nominal Frequency:	50.0 Hz

Power Source Ratings	
100% Full Load (FL) :	1000.0 kVA
at Power Factor:	0.80
Full Load Tolerance:	140.0 % FL

 The loadbank is programmed to test a power source with the ratings shown above.

Once the generator has been correctly specified the next part of the start-up sequence can be performed.

At this point a screen may be displayed enquiring if the operator wishes to retain previously learned loads. Learned loads are stored whilst working on a particular piece of equipment to allow a specific load to be recalled. If the loadbank is being used with the same equipment as when the loads were learned, and there have been no other changes in the test environment, then the loads may be retained. Otherwise the learned loads are invalid and should be erased.

The final part of the start-up sequence displays the screen below inviting the operator to start the loadbank cooling fans.

The screenshot shows a software window titled "Loadbank Startup Sequence". It contains the following sections:

Cooling Fan Status: Fans are not Running

Standing Powers	
Loadbank 1412:	0.0 kW
	0.0 kVAr
System Totals:	0.0 kW
	0.0 kVAr

Fan-Start Time Out: Not Active

 The loadbank cooling fans may be started at this time or the startup sequence can be completed without the fans running. In this case the fans will be started before the first load is applied.

Pressing the Start Fans button will begin the fan start sequence. This may take up to a minute to complete depending upon the number of cooling fans fitted within the loadbank. Alternatively, if the Finish button is pressed then the computer defers the starting of the fans until a load is to be applied. This enables parameters to be set-up without the distraction of fan noise.

Once the fans have been started the standing power that they are consuming will be displayed in the dialog box. To view the standing power for an individual loadbank select the required unit from the drop-down list.

The start-up sequence is now complete. Pressing the Finish button will show the main instrumentation display. The loadbank is now ready for use.

4.0 Instrumentation Display

The Eclipse software has two different display modes to present the loadbank instrumentation readings to the operator. The load measurements can be displayed in either digital format or represented using analogue meters.

To change the display mode select either the Analogue Instruments or Digital Instruments option from the View menu.

4.1 Digital Instrumentation

When selected the digital instrumentation display is as shown below.

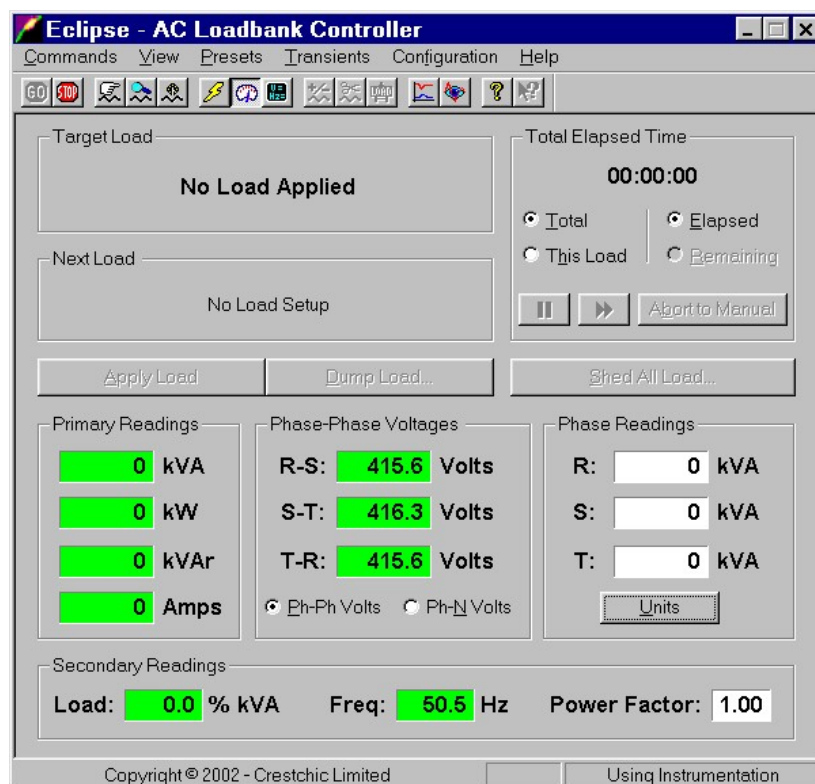

At the top of the display is the load information. The Target Load area shows the details of any applied load whilst the Next Load area displays details of the next load to be applied if one has been set-up.

To the right of the load information is the timing information display. Using the radio buttons in combination it is possible to show the elapsed time since the start of the load-test or since the last load was applied. When using the Automatic Load-Profile mode it is also possible to view the remaining time until the next load-change or until the entire load-profile is completed. The three buttons below the radio buttons are used when executing an automatic load-profile and are discussed in that section of this manual.

Below the load information and timing areas of the display are three buttons that control the load application and removal. Once a load has been set-up ready for application the Apply Load button will become active and when pressed the load will be applied by the loadbank. Once applied the button will change function to become a Re-Apply Load button. This may be useful if the initial load application causes the voltage output of the generator to change. Hence the applied load that was calculated using the voltage prior to the load-change may be slightly incorrect. Pressing the Re-Apply Load button will re-calculate the load parameters using the latest voltage measurements to give a more accurate load.

The Dump Load button is activated once a load is applied. The dump facility enables the load to be shed in 25% stages. It can be used as a "Panic Button" if too much load is applied to the power source. The Dump Load button can be used repeatedly to reduce the load down to a safe level.

The Shed All Load button can be used to conclude the testing at any time and remove all loading from the test supply. The operator will be asked to confirm they wish to end the test so that the inadvertent operation of this button will not cause the load to be shed.

Below the load control buttons are the instrumentation displays. The primary instrumentation area shows the total powers and current being drawn from the test supply. These displays are colour-coded to indicate when the limits of the test supply are being reached. The readings will be show in the green until within 5% of the selected full-load tolerance percentage. Once above this the display will change to amber until the full-load tolerance is exceeded by 2% at which point the display will show red. For example, if the full-load tolerance is 110% then the primary instruments will display green for reading up to 105% of the generators rating. The displays will show amber for measured values between 105% and 112% of full-load and the show red when the readings exceed 112% of full-load.

The voltage measurements are given in the centre of the display. By using the radio buttons either the phase-phase or phase-neutral values can be selected for display. These displays are also colour-coded to indicate when the loadbank operating limits are being reached. The displays will normally show green but will turn amber when the measured voltage comes within 2% of the maximum or minimum loadbank operating voltage. Once the voltage limit is exceeded then the display will show red.

On the right of the display are the phase readings displays. By pressing the Units button the kVA, kW or Amps in each phase can be shown in this area. Pressing the Units button also determines the units in which the applied load and next load are expressed.

Finally at the bottom of the display are the secondary readings. These are the percentage full-load, measured frequency and power factor readings.

The percentage full-load is expressed in the currently selected units and is colour-coded using the same scheme as described above for the primary readings.

The measured frequency is shown centrally and the colour coding on this indicates if the reactive load component is operating within its limits. The same limits as given above of the voltage measurements apply. For example, the reactors in the loadbank cannot usually be used above 440V on a 50Hz supply. Therefore the frequency reading would show amber when the voltage reached 431.2 volts and then show red when the 440V limit was exceeded.

4.2 Analogue Instrumentation

When the analogue instrumentation display is selected the Eclipse window changes to that shown below.

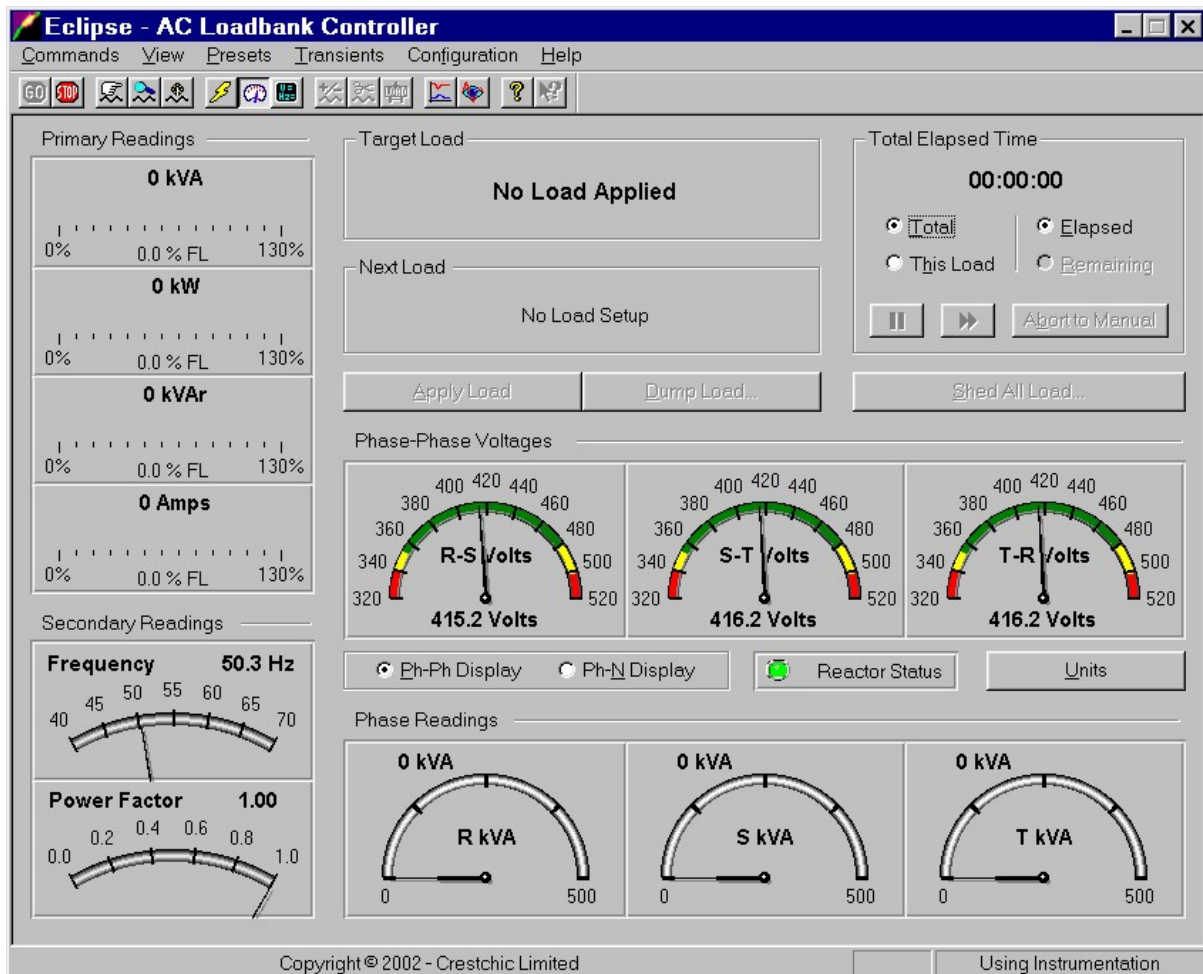

The load information area and timing details area of the analogue instrumentation are as described in the previous sub-section as is the operation of the load control buttons.

The primary readings are now located in a column on the left of the display. Each reading is represented by a bar indicator. The colour of the bar indicates how close the measured value is to the full-load tolerance of the test supply. The colour coding is as described for the primary instrumentation in the previous sub-section.

Below the primary instrumentation is the secondary instrumentation with the measured frequency and power factor being displayed on the meters.

At the centre of the display are the voltage meters that can display either phase-phase or phase-neutral values. These meters show the entire span of the permissible voltage range and indicate if the test-supply voltage is within the loadbanks operating range. The colour-coding scheme is the same as that described for the voltage displays on the digital instrument screen.

The reactor status indicator shows if the loadbank reactors are being operated at too high a voltage for the supply frequency. This indicator will show amber when the operating limit is approached and red once the limit is exceeded.

Finally at the bottom of the analogue instrumentation screen are the phase reading meters. These meters can show either the kVA, kW or Amps flowing in each phase of the test supply. Pressing the Units button will select the parameter to be displayed.

5.0 Manual Loads

This mode offers the simplest form of loadbank control where a load, as the name implies, is set-up by the operator and applied to the equipment under test. The load can be defined in terms of the required load current (Amps), the true power (kW) or the apparent power (kVA), and the power factor. The computer will calculate the necessary resistive and reactive components from these entries.

5.1 Load Preparation

To set-up a load prior to its application select the Set-up Manual Load option from the Command menu or press the  button on the application toolbar. This will display the Manual Load Preparation dialog box shown below.

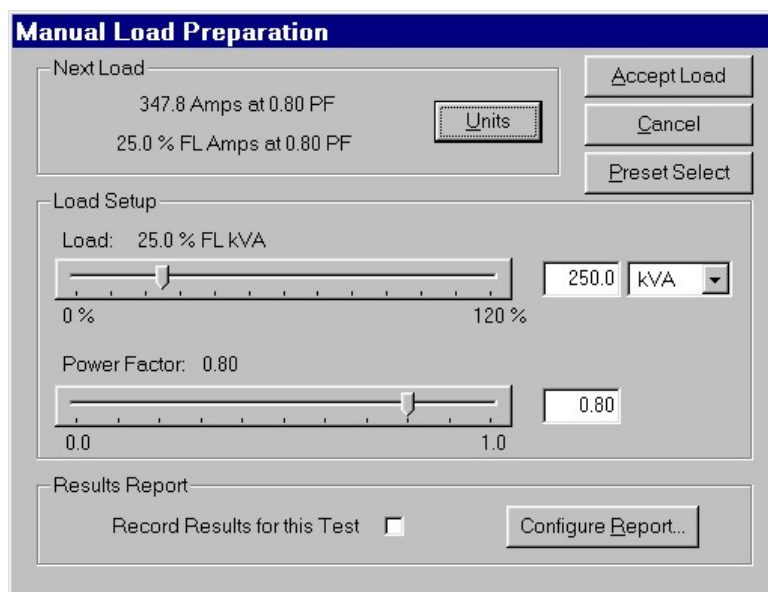

The dialog box is titled "Manual Load Preparation" and is divided into three main sections. The top section, "Next Load", displays the current load settings: "347.8 Amps at 0.80 PF" and "25.0 % FL Amps at 0.80 PF". To the right of this section are three buttons: "Accept Load", "Cancel", and "Preset Select". A "Units" button is located between the load display and the "Accept Load" button. The middle section, "Load Setup", contains two sliders. The first slider is for "Load" and is set to "25.0 % FL kVA". The slider range is from 0% to 120%. To the right of the slider is a text box containing "250.0" and a drop-down menu currently showing "kVA". The second slider is for "Power Factor" and is set to "0.80". The slider range is from 0.0 to 1.0. To the right of this slider is a text box containing "0.80". The bottom section, "Results Report", contains a checkbox labeled "Record Results for this Test" which is currently unchecked, and a "Configure Report..." button.

The load can be entered by selecting the appropriate units from the drop-down list box and then typing the size and power factor into the edit boxes. Alternatively the load can be set-up by using the slider controls to define its magnitude and power factor. When entering the load in Amps or kVA a power factor from 0.0 to unity may be used. When entering the load in kilowatts the power factor entry is limited to 0.1 as a minimum.

If a resistive-only loadbank is being used then the power factor will automatically be set to unity and the operator will not be able to alter this value.

The details of the entered load are displayed at the top of the dialog box and the units in which these are expressed can be changed independently by pressing the Units button.

If this is the first load to be applied the operator is also given the chance to record the instrumentation readings throughout the test to the PC hard disk. To do this click on the checkbox in the Results Report area of the dialog box. For more information about the Results Report and its configuration see the Configuration Options section of this manual.

As an alternative to defining the load the operator may select a preset load from a list of twenty pre-programmed loads. To do this press the Preset Select button to display the list of available presets. The Manual Load Preparation dialog box will then change to that shown below.

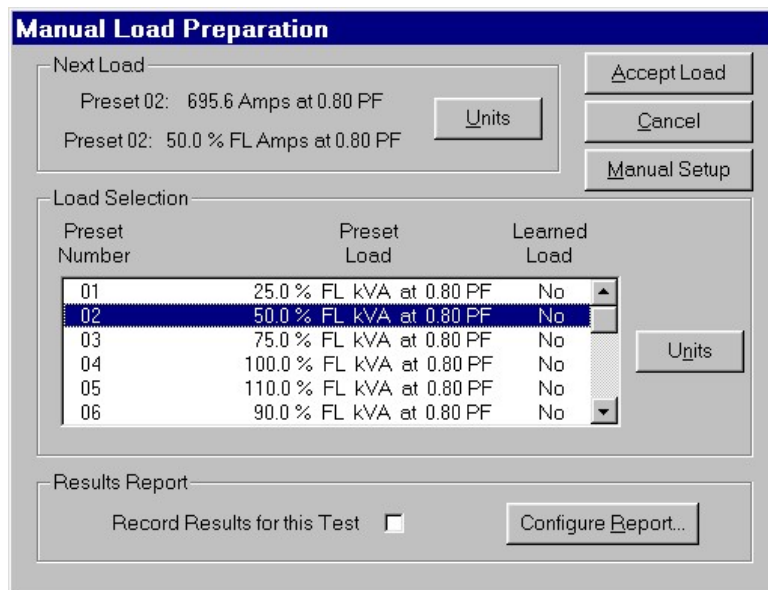

To select a preset load simply highlight the required entry in the list box and press the Accept Load button. Alternatively the load can be selected in one step by double-clicking the desired preset in the list box. For more information of preset loads and their programming see the Preset Loads section of this manual.

Once the Accept Load button is pressed the computer will check that the entered load does not exceed the generator limits, as defined during the Start-up Sequence. Should there be a problem a message box will display the cause of the error and the operator will be prompted to re-enter the load.

Once the new load has been accepted the Manual Load Preparation dialog box is dismissed and the Instrumentation Display shows the load details in the Next Load area. Note that the load is not yet applied at this stage.

5.2 Load Application and Control

Once the load has been prepared its details are shown in the Next Load area of the screen. To apply the load the Apply Load button must be pressed. If this is the first load of a test and the operator has elected to produce a record of the measured values then a dialog box will be displayed giving details of the Results Report filename and location. Once this has been accepted the new load will be applied by the loadbank and the display will start continually updating with measured values.

A typical screen from when the loadbank is on-load is reproduced below.

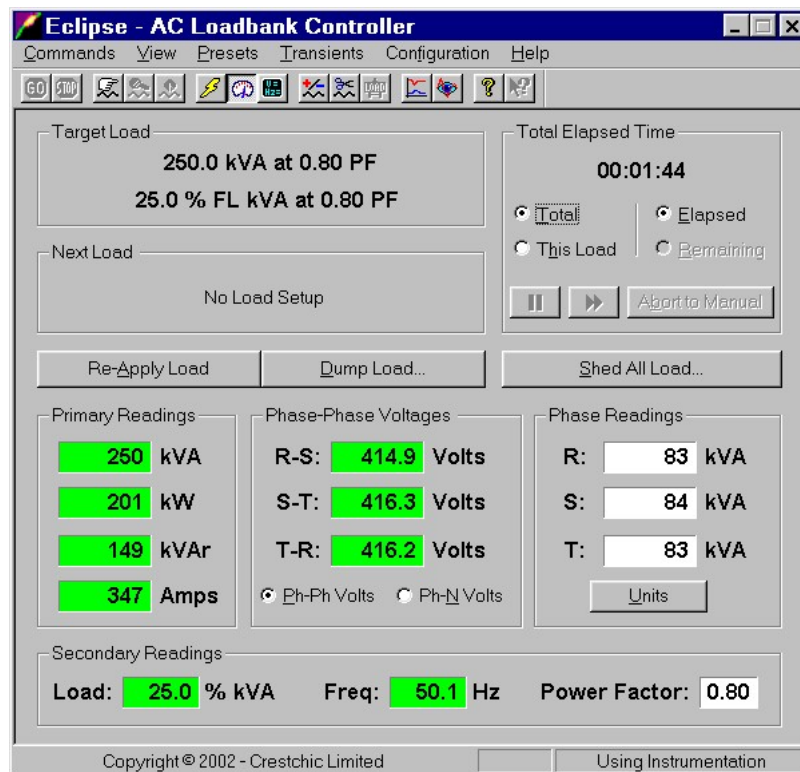

The loadbank can perform step changes by altering the load to a higher or lower value from the currently applied load. This is done in the same way as described in the previous subsection. Select the Set-up Manual Load option from the Command menu or press the  button on the application toolbar to call up the Manual Load Preparation dialog box.



Once the new load has been entered and accepted its details are shown in the Next Load area of the display. Again the new load has not yet been applied at this point but is set-up ready for when the Apply Load button is pressed.

The operator may conclude the testing at any time by pressing Shed All Load button. Once this is confirmed the loadbank will remove all load from the test supply.

As an alternative to shedding the entire load at one time, the Load Dump button may be used to shed the load in 25% stages.

6.0 Load Calculation

During the calculation of the load necessary to draw the power requested by the operator the computer utilises values for voltage and frequency. Either the nominal values for the generator or the actual transducer values measured by the loadbank instrumentation during the load test can be used in the load calculation. The operator must select whichever source of voltage and frequency figures will be most suitable.

To use the loadbank instrumentation values select the Use Instrument Values from the Configuration menu or press the  button on the toolbar. To use the test supply nominal values choose the Use Nominal Values option from the Configuration menu or press the  button on the Eclipse toolbar.

The operator may switch between either of the sources at any time. The status bar indicator will display the currently selected option.

There are advantages and disadvantages to both sources of these values. If nominal values are used these are obviously fixed throughout the range of the test, whereas the voltage supplied by the equipment being tested may fall as the load is increased. In this case the use of measured values would be more appropriate.

Alternatively, if there is significant voltage drop between the generator output terminals and the loadbank bus bars, where values are measured by the instrumentation, then using the nominal values of the generator output will give a more accurate load calculation. It is up to the operator to select which mode to use based on the individual circumstances of each installation.

When the Eclipse program is first launched it always defaults to using measured values as this method generally gives the more accurate results. If nominal values are to be used the operator must explicitly change to this mode of operation.

Finally, when using the Nominal Values option the loadbank does not check for violation of the minimum operating voltage. This allows the loadbank to perform “dark-start” testing where a load can be set up and applied to a generator’s outputs before the generator is started.

7.0 Load Adjustment and Trimming

When the operator enters a load the loadbank computer will calculate the required resistive and reactive components that are required to produce the requested load. For several reasons however it may happen that the calculated load does not produce exactly the requested load in reality. In these circumstances the Eclipse software allows two mechanisms that can be used to alter the applied load to produce more accurate results.

The first option is Load Adjustment in which the loadbank computer will change the applied load gradually until the target load entered by the operator is reached. The second option is Load Trimming. This mechanism allows the operator to interactively modify the applied load to meet his own requirements.

7.1 Load Adjustment

Load Adjustment is used to obtain the requested load by modifying the size of the load components that were initially calculated prior to the load-change. This compensates for any changes that occur after the load has been applied, for example voltage-drop due to the loading on the generator, or thermal drift causing the loadbank elements to change resistance as they heat-up.

To enter the Load Adjustment facility select the Auto Load Adjust option from the Command menu or press the  button on the toolbar. The Load Adjustment dialog box will then be displayed. This is shown below.

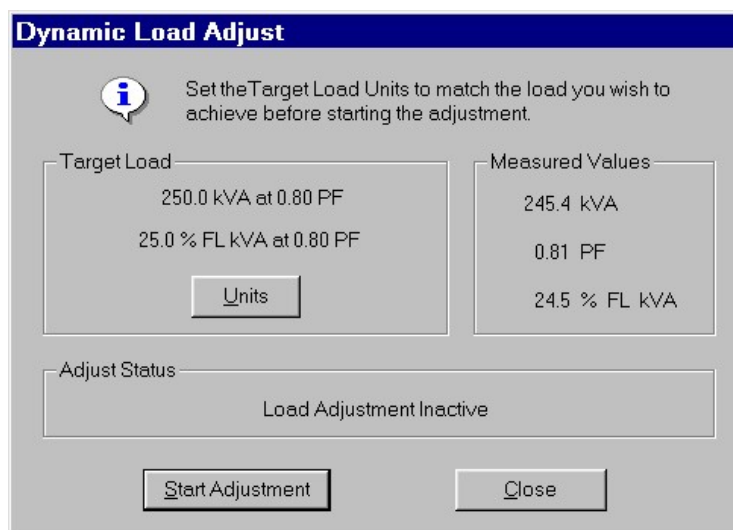

Load Adjustment will modify the resistive and reactive components of the applied load to try and achieve the target load in the selected units. For example, if the target load is expressed in Amps it will strive to produce the requested current, which may result in the kW or kVA being incorrect due to voltage variations. It is therefore important to use the Units button to display the required target load in the desired units before starting the adjustment.

Pressing the Start Adjustment button will start the load modification causing the computer to adjust the applied load whilst comparing the measured load to that requested by the operator. This continues until the requested current or power is being taken from power source under test. If, during the adjustment, the same button is pressed again the load adjustment ceases and the load is left at the value it has reached.



During the Load Adjustment procedure the measured values are displayed in the dialog box and these will be seen to approach the requested target load as the adjustment progresses. Once the requested target load has been attained the load adjustment will stop and the operator can dismiss the Load Adjustment dialog box by pressing the Close button.

7.2 Load Trimming

Another situation where the calculated load may lead to an incorrect total load is when there is an additional standing load on the test supply, other than that supplied by the loadbank, such as the power supply for the generator services. In this case the option is available to manually trim the loadbank load so that the total load, as seen at the generator, is equal to the nominal value of the requested target load. This facility is also useful to trim the load to match external instrumentation.

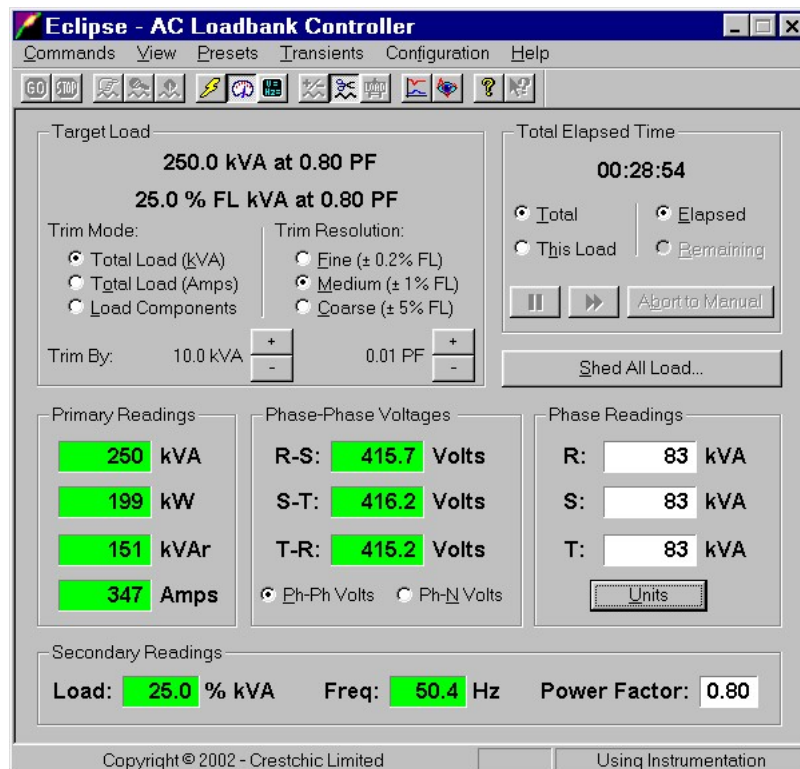
To enter the Load Trimming facility select the Load Trim Mode option from the Command menu or press the  button on the toolbar. This will cause the Instrumentation display to change and new controls to appear in the target load area. The modified Instrumentation display is shown below.





When the Load Trimming facility is selected the Trim Mode can be selected by clicking the appropriate radio button. These modes are discussed in detail below. The amount by which the load is changed in each step is determined by the chosen trim resolution. This can be selected to be coarse, medium or fine using the appropriate radio button. The applied load is manipulated using the four buttons marked  or  at the bottom of the target load area.

Load Trimming offers the operator a choice of three modes. In either of the Total Load modes the left-hand pair of trim buttons will increase or decrease the kVA or Amps of the applied load by 5% (coarse), 1% (medium) or 0.2% (fine) of the defined full-load power of the test supply, whilst maintaining the power factor at its current value. For example, if a 300 kVA generator is being used the load will be changed by 15 kVA every time one of the left-hand pair of trim buttons is pressed, assuming that Total Loads (kVA) is the chosen Trim Mode and coarse resolution selected.

Similarly, in either of the Total Loads modes, the right-hand pair of trim buttons will alter the Power Factor by 0.05 (coarse), 0.01 (medium) or 0.002 (fine) each time they are pressed whilst maintaining the magnitude of the applied load.

When Load Trimming facility is being used in Load Components mode the action of the trim buttons is somewhat different, allowing direct control of either the resistive or reactive components of the load. Pressing either of the left-hand pair of trim buttons will change the resistive part of the load by 5%, 1% or 0.2% of the total resistive full-load power, depending upon the selected resolution. The reactive load component will not be changed which means the power factor will also alter.

When the right-hand trim buttons are used in Load Components mode they act only upon the reactive part of the load. The  button will increase the amount of kVAr being applied by the Trim step size shown on the screen. Similarly the  button will reduce the kVAr by the Trim step size shown.

The Trim Mode and Trim Resolution may be changed at any time during the trimming operation so that the desired step size can be achieved. As the mode and resolution are altered the values displayed next to these buttons will change to indicate exactly how the applied load will be affected by the operation of the trim buttons.

It will of course be realised that in any Trim mode the right-hand pair of trim buttons will have no effect when using resistive-only loadbanks, as these have no reactive component to apply.

As a safety feature when using the Load Trimming mode the Eclipse software will only allow the applied load to be altered by $\pm 10\%$ of the nominal target load. Once this limit is reached the appropriate trim buttons will become disabled.

When the operator has finished manipulating the applied load using the Load Trimming facility the normal Instrumentation screen can be redisplayed by de-selecting the Load Trim Mode option on the Command menu or releasing the  button on the toolbar.

7.3 Learned Loads

If the target load is one of the twenty primary presets stored in the loadbank it is possible to store details of any alteration that has been made to the nominal load from the use of the Load Adjustment or Load Trimming facilities. The modified load details are stored with the other preset information by the loadbank computer. This is called a Learned Load.

The next time the preset is called the loadbank will use the modified load value and this should result in the applied load being very close to the desired value, provided the generator voltage and frequency output are not significantly different from when the load was initially learned.

Once a load has been modified using the Load Adjustment or Trimming facility it can be learned by selecting the Learn Load option from the Presets menu or pressing the  button on the application toolbar. The operator will be asked to confirm the action and then the revised loading details will be stored in the loadbanks non-volatile memory.

When the currently applied load is a learned load this will be indicated in the status bar.

7.4 Summary

Reviewing the Load Adjustment and Trimming options – the loadbank will initially calculate a load which when applied may not draw the desired power.

The operator can use either the Load Adjustment or Load Trimming facility to modify the applied load to that required and then this corrected load can be learned if the target load is a preset.



Next time the preset is called upon the Learned Load is applied and this should be close to the desired value.

8.0 Search Mode

This mode of operation is different from that previously described in the Manual Loads section of this manual. The purpose then was to apply a load to the equipment under test to ensure it had the capacity to provide the required power. In search mode the load can be freely manipulated by the operator to hunt for inconsistencies or critical nodes throughout the range of the equipment under test.

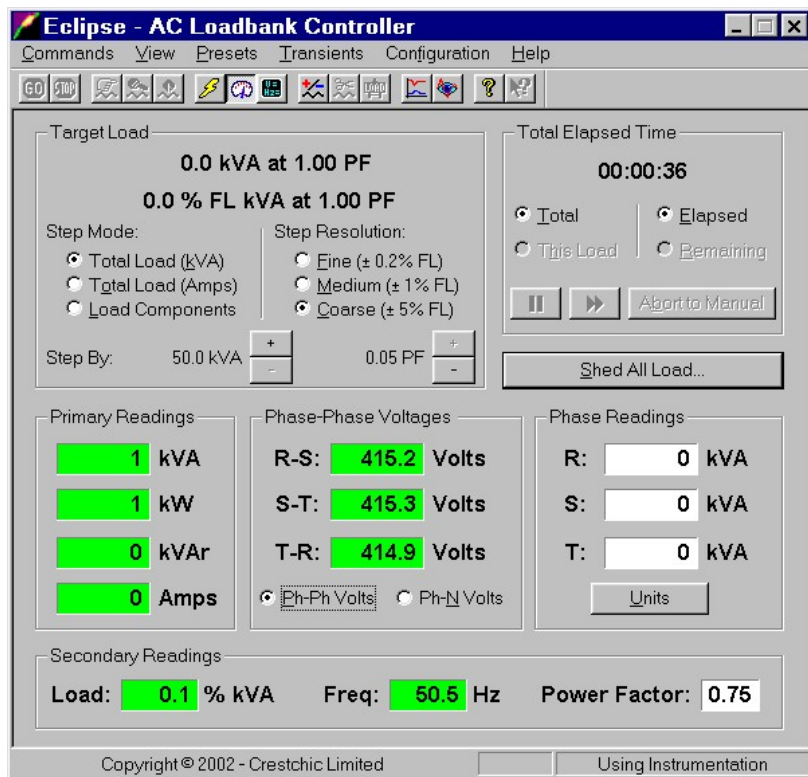
Search Mode is entered by selecting the Search Mode option from the Command menu or by pressing the  button on the toolbar. This causes the Instrumentation display screen to change and additional load manipulation controls to be displayed similar to those used when Load Trimming is used. There is initial starting load of zero kVA at unity power factor. The Instrumentation screen displayed in Search mode is shown below.



The size and power factor of the load are manipulated using the  and  buttons in the same way as described in the Load Trimming sub-section earlier in this manual. Any load can be achieved up to the test supply's full-load tolerance with any power factor from zero to unity, assuming the loadbank has the capacity to provide the load. The target load will change to show the nominal applied load as the load-step buttons are pressed.

The size of each load-step is determined by the resolution and this can be altered at any time by clicking a different resolution radio button. The operator is reminded that the load-step buttons operate on the load in a different way when the loadbank is in Load Components mode from when it is in one of the Total Load modes. Please refer to the description of Load Trimming given previously for full details.

The Load Adjustment feature is available in Search Mode to allow the computer to alter the load to obtain the target load displayed at the top of the screen.

To end the Search Mode operation press the Shed All Load button. The operator will be asked to confirm that all applied load should be removed. If this is the case, the loadbank will drop the applied load and exit Search Mode. The load manipulation controls will disappear and the standard Instrumentation screen will be displayed.

8.1 Stored Nodes

In Search mode there is provision for seven nodes to be stored in non-volatile memory. These are entirely separate and independent from the Preset Loads mentioned so far. When a point of interest is reached the load details can be stored as one of these nodes.

Selecting the Store Node option from the Presets menu will display the Node Selection dialog box shown below.

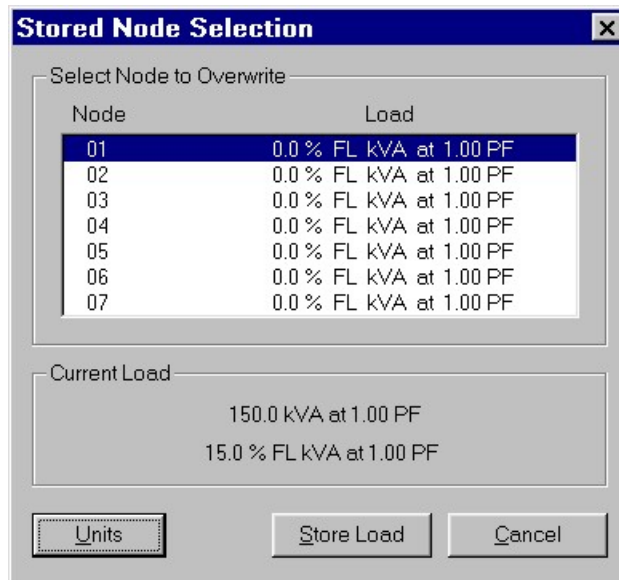

The load is displayed in both the current units and as a percentage of the test supply's full-load. Pressing the Units button will display the current load and node details in the different load units.

To store the current load highlight the desired node in the list box and press the Store Load button. Alternatively the required node can be double-clicked. In either case the operator will be asked to confirm that the old load information in the selected node should be overwritten with the current load details, and if so the new load for the chosen node will be stored in the loadbanks non-volatile memory.

8.2 Applying a Stored Node

To recall and apply a previously stored node select the Apply Stored Node option from the Preset menu to display the Node Selection dialog box.

The Node Selection dialog box that is displayed when a stored node is to be applied is shown below.

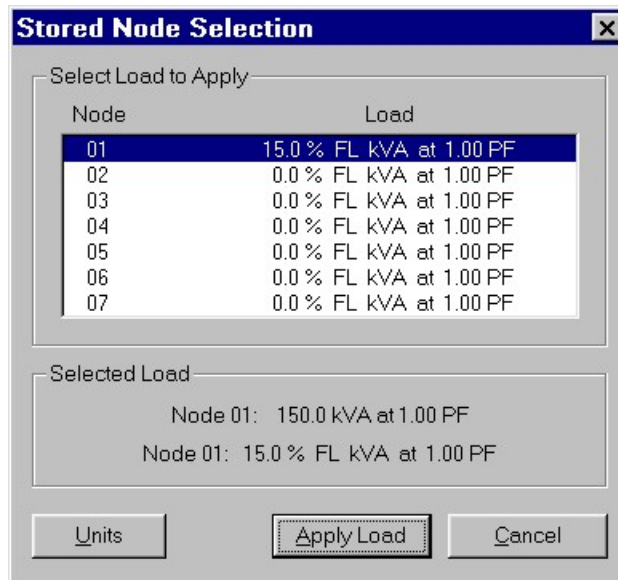

The operator should select the required node from the list box. The load details for that node will be displayed in the Selected Load area and if these are acceptable the Apply Load button should be pressed to instruct the loadbank to set the new load. Alternatively the required node in the list box can be double-clicked. In this case the selected load will be applied immediately.

Once a stored node has been applied the operator can continue to manipulate the applied load from that point using the load-step buttons.

9.0 Preset Loads

When using the Manual Loads mode described earlier in this manual the use of pre-programmed loads has been introduced as an alternative to specifying the required next load by direct data entry. The preset loads are also the building blocks for a Load Profile, which may be automatically executed by the computer. This mode of operation is discussed later in this manual.

This section describes the characteristics of these preset loads and how the operator may program them.

9.1 Overview

The loadbank computer stores details of twenty pre-programmed loads. These preset loads are each expressed as a percentage of the test supply's full-load power together with a power factor value. The default duration for the preset load, used when in Automatic Load Profile mode, is also stored as part of the preset details.

The above information defines the base load for a preset. Base load presets may be programmed as any percentage of the generators full-load rating. However, if an attempt is made to program a preset above the current full-load tolerance a warning message will be displayed. The preset will remain programmed at this level but its application will not be permitted in either Manual Loads or Automatic Load Profile Mode.

Each of the twenty base presets can be modified to include the addition of an M-Test load. The M-Test, or Motor Test, is mainly used, as the name implies, to provide generators with a short-duration overload test that simulates the starting of a motor. When the M-Load is added to a Base Load preset the computer will add the M-Load to the base load of the preset to produce a composite load. This is the load that will be applied to the generator under test when that preset is used. The composite load is calculated automatically with no need for the operator to become involved in complex mathematics.

Presets that include an additional M-Load are usually used to test extreme overload situations. Therefore these types of presets are permitted to exceed the generator full-load tolerance. This is the **only** time the loadbank will allow a load above the full-load tolerance of the test supply to be applied. As a safety precaution the use of Base + M-Load presets is limited. They can only be applied as part of an Automatic Load Profile under computer control, and then only for a maximum duration of ten seconds.

Another feature of preset loads is that if their nominal load is modified using the Load Adjustment or Load Trimming facilities then the altered load can be stored so when the preset is called upon again the loadbank will apply this new load. This mechanism has been discussed in the Load Adjustment and Trimming section earlier in this manual.

When using the Eclipse software with a PC the preset loads can be used to for a load-profile in any order and their duration modified as required. However, if the presets are also to be used when operating the loadbank with an HHT100 controller then each preset can only be used in numerical order and for the default duration. This may determine the order in which the operator defines the preset loads to allow the load to ramp up and down again sequentially.

9.2 Defining the M-Load

If the M-Load is to be used with any of the presets then this should be defined first. Selecting the Set M-Test Load option from the Presets menu will display the dialog shown below allowing the M-Load to be defined.

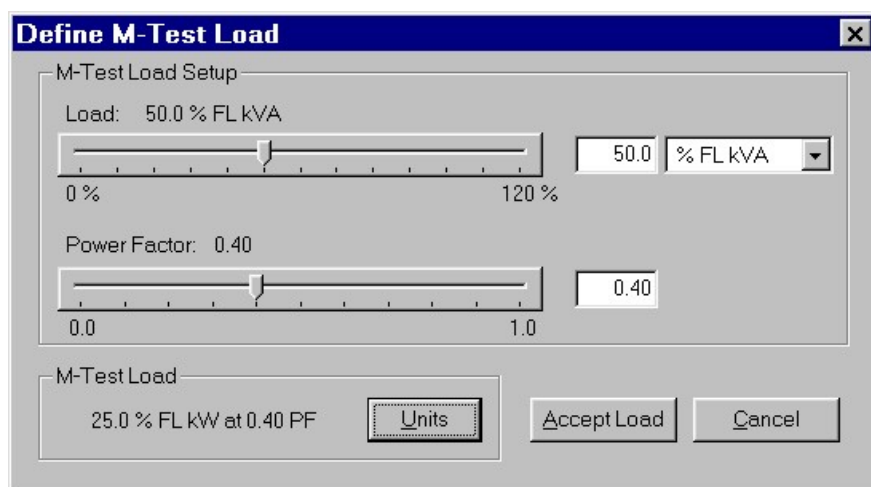

The units for the M-Load can be selected from the drop-down list. The magnitude of the load, expressed as a percentage of the full-load rating of the test supply in the selected units, and power factor can then be entered directly into the edit boxes. Alternatively the slider controls can be used to define these parameters. The M-Load is displayed at the bottom of the dialog box and this can be expressed in any of the load units by pressing the Units button.

Once the M-Load has been defined press the Accept Load button to update the M-Load and dismiss the dialog box.

If the M-Load is changed, and it is currently included in any of the twenty preset loads, then the M-Load will be removed from those presets and they will revert solely to their base loads. Therefore the M-Load should be defined before programming any of the presets that will utilise it.

9.3 Programming Presets

To program any of the twenty preset loads stored by the loadbank choose the Program Preset Loads option from the Presets menu.

The dialog box shown below will be displayed allowing the selection of the preset to be programmed.

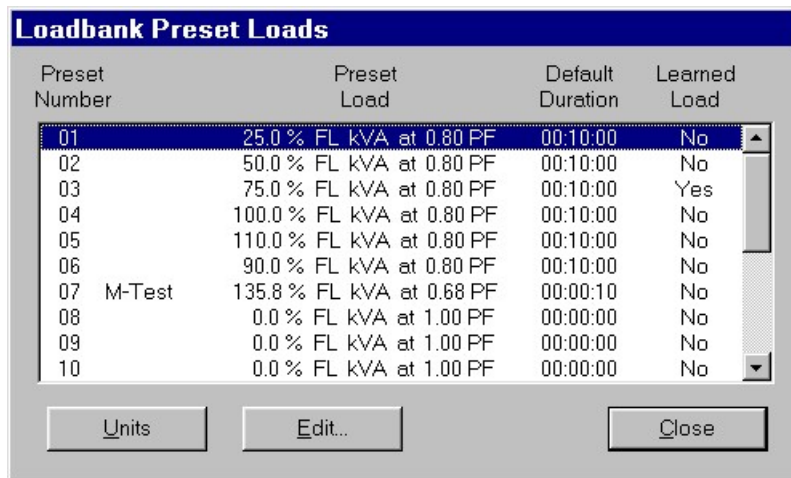

The display shows each preset load as a percentage of the test supply's full-load rating, the power factor, the preset duration and whether the preset includes the M-Load. To view the presets expressed in different units press the Units button. To select a preset for programming highlight the required item in the list box and press the Edit button. Alternatively just double-click the required preset in the list box.

Once a selection is made the details of that preset are shown and may be edited. This screen is reproduced below.

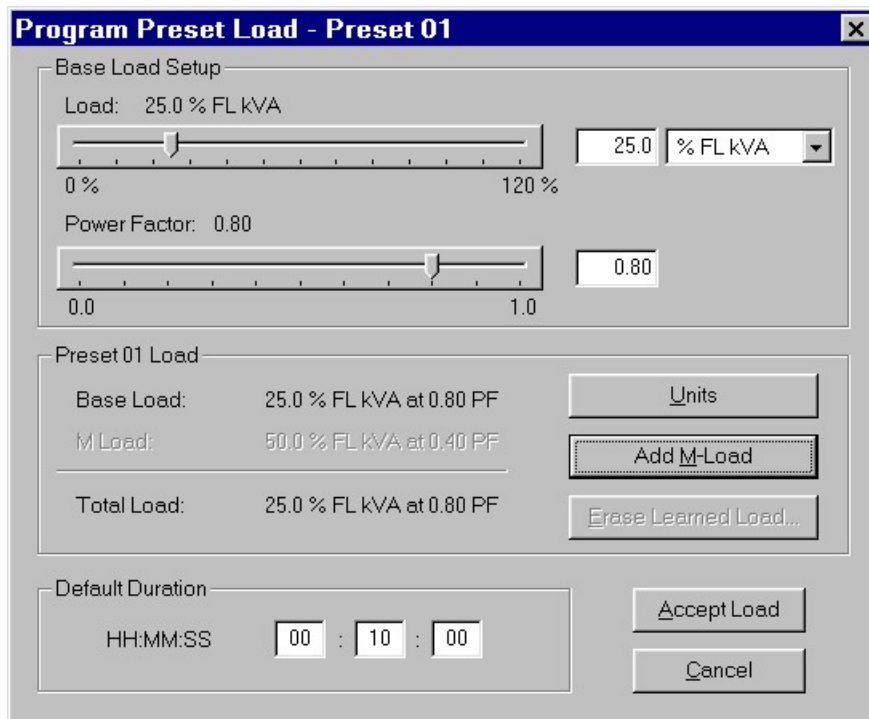

The base load for the preset may be set-up in the required units by typing values into the edit boxes or using the slider controls to specify the magnitude and power factor. The load is displayed in the centre of the dialog box and this can be expressed in different units independently from those being used to define the load by pressing the Units button.

The M-Load is displayed below the Base Load and can be added to the Base Load by pressing the Add M-Load button. The total size of the composite load for the preset is shown below this.

If the preset has a Learned Load assigned to it the Erase Learned Load button will be enabled, allowing the stored load to be removed. Once this is done the preset will return to its normal behaviour and calculate its nominal load value when applied.

The duration is only applicable if the preset is to be used as part of an Automatic Load Profile where loads are sequenced by the computer. Should this be the case enter the duration in the edit boxes at the bottom of the dialog box. It is recommended that the duration of a base preset should be not less than ten seconds.

Presets that include the M-Load are allowed to exceed the full-load tolerance of the test supply and so should only be used for a short duration. Therefore, as a safety feature, if the preset includes an M-Load then the duration will not be allowed to exceed 10 seconds.

Once the preset load has been satisfactorily specified press the Accept Load button to store the preset parameters. If the preset has been defined to be in excess of the current test supply limits a warning message will be displayed informing the operator that this preset cannot be used with the current test supply. The preset details may still be stored if desired or the operator can elect to re-enter the load details so that the preset can be used with the existing test supply.

After the load for the preset has been accepted the Preset Selection dialog box will be displayed allowing another preset to be programmed in the same manner, or this can be dismissed if the editing of presets is complete.

10.0 Automatic Load Profiles

In this mode a Load Profile made up of a number of preset loads is applied by the computer, which initiates each load change after a specified duration. The Load Profile loads are sequenced through in order until the entire list is completed.

Before the Automatic Load Profile mode can be used the Load Profile must first be defined. This can either be a previously prepared profile that is loaded in from the PC hard disk or a new Load Profile can be created from scratch.

10.1 Creating a Load Profile

To create a new Load Profile or edit an existing profile that has been loaded from hard disk select the Create/Edit Load Profile option from the Presets menu. The dialog box shown below will be displayed.

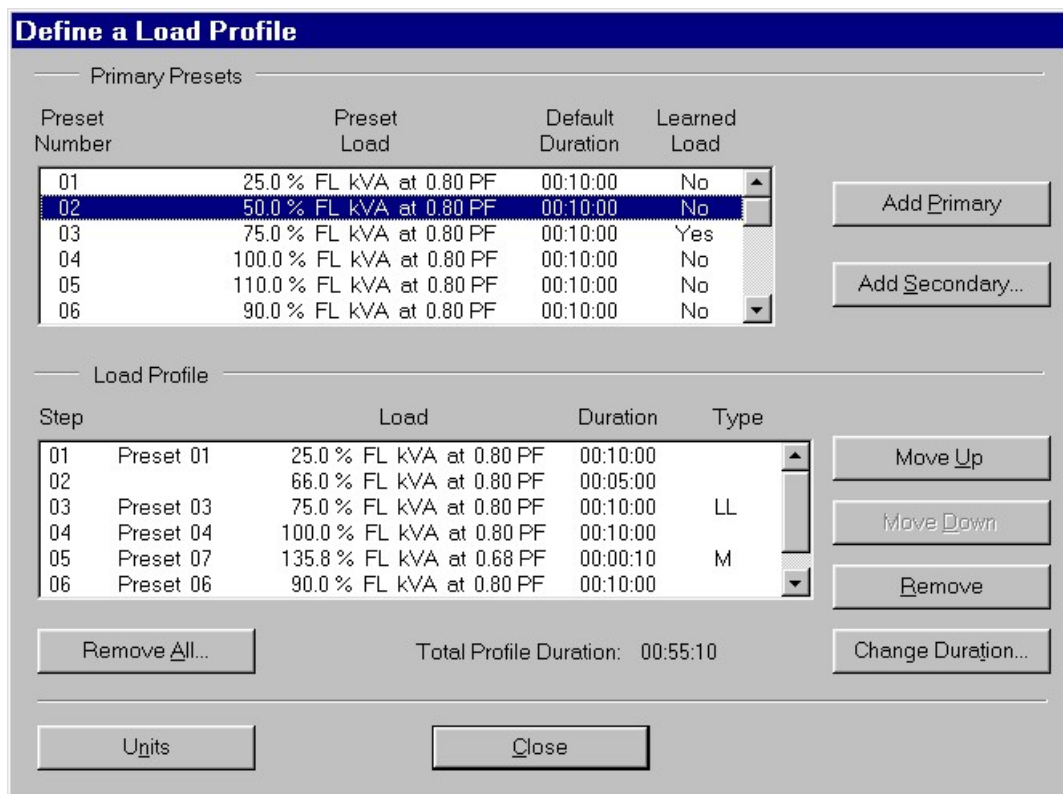

The dialog box is split in to two main parts. The top half has a list box that displays the twenty preset loads that are currently stored in the loadbank memory. These are referred to as Primary presets.

The bottom half of the dialog box has a list box that displays the current Load Profile as it is built up. If no Load Profile has been read from the PC hard disk this list box will initially be blank.

The Load Profile is built up one step at a time by selecting each required preset load from the list of Primary presets and then adding it to the list of loads in the Load Profile. To do this highlight the desired preset load in the top list box and press the Add Primary button. Alternatively the required preset can simply be double-clicked to add it to the Load Profile. In either case the selected preset is added to the end of the list in the Load Profile and will be displayed in the bottom list box.

As an alternative to using the Primary presets a load may be added to the Load Profile that does not appear in the list of twenty presets. This type of load is called a Secondary preset. Press the Add Secondary button to do this. A dialog box similar to that used to program a preset load is displayed and the operator can define the load magnitude, power factor and duration that is required for the Secondary preset. Once the load is accepted it will appear at the end of the list in the Load Profile list box.

As a Secondary preset is not stored in the loadbank it should be realised that it will not be possible to apply this load when using Manual Loads mode. Further it is not possible to use the Learned Load feature with a Secondary Preset.

The Load Profile list box is in the bottom half of the displayed dialog box. This gives information about each step that is part of the profile. If the step is a Primary preset then the Preset number is displayed; for a Secondary Preset no number is shown. Information about the type of preset is also given. If the preset includes the M-Load then the letter M is shown in the list box. If the preset is a Learned Load the letters LL are displayed.

The Load Profile may be altered by changing the order of the steps in the list, or by removing a step totally from the profile. To do this, select the required step in the Load Profile list box and press the Move Up or Move Down buttons to change its position in the profile list. To delete entirely a selected load step from the profile press the Remove button.

It is also possible to change the duration of a Primary preset when it is part of the Load Profile. This allows the same preset to be used in several places in the Load Profile with a different duration at each occurrence. To alter the duration of a Load Profile step select the desired step in the Load Profile list box and press the Change Duration button. A dialog box will be displayed allowing the revised duration to be entered. This does not effect the default duration of the preset stored in the loadbank.

To clear all the steps from a Load Profile press the Remove All button. Once the operation is confirmed the entire Load Profile will be deleted from memory.

Using the mechanism described above the required Load Profile can be quickly and easily constructed and edited using any mixture of Primary and Secondary presets intermingled in any order. There is no practical limit to the number of steps that can be used to form a Load Profile.

Once the Load Profile has been defined pressing the Close button will dismiss the Profile definition dialog box. The Load Profile is now ready for use.

10.2 Writing a Load Profile to Disk

Once a Load Profile has been created it is possible to write a Load Profile Report to a file on the PC disk. This report contains all the information necessary to define the loadbank configuration for a particular load test profile.

Once a Load Profile Report file is resident on the PC hard disk it is possible, at a later date, to re-program the load profile in the loadbank from the information contained within the report file. A library of test profiles for different pieces of equipment can be built up on a PC hard disk and then uploaded to the loadbank as required. This process is much quicker than manually entering the profile details via the keyboard every time a different power source is to be tested.

To write the Load Profile Report to the PC hard disk select the Write Load Profile option from the Presets menu. The dialog box shown below will be displayed.

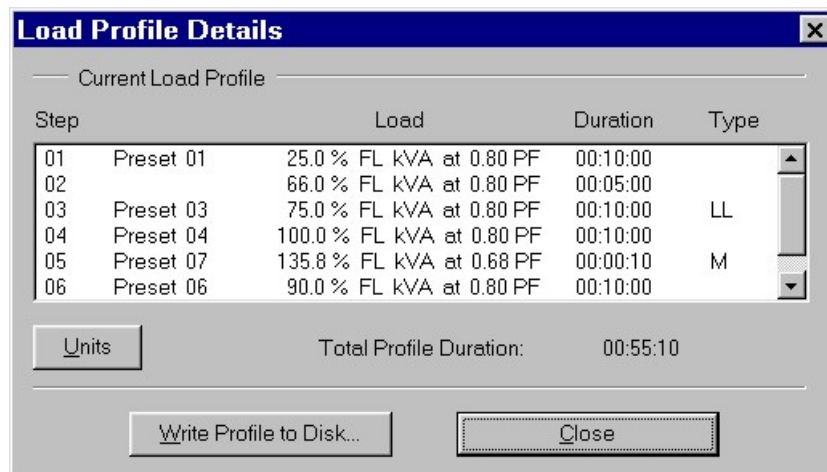

The operator can view the current Load Profile displayed in the list box and if satisfied with the contents it will be stored on the PC hard disk when the Write Profile to Disk button is pressed.

The report file will be written as a standard text file. This file will be automatically deleted after a specified number of days unless it is renamed and/or copied to another directory. For more details about the file handling and naming conventions and the Load Profile Report contents see the PC File Information section appended at the rear of this manual.

10.3 Reading a Load Profile from Disk

To upload a Load Profile Report file select the Read Load Profile option from the Presets menu. A dialog box similar to that shown above will be displayed with details of the current Load Profile, if any, displayed in the list box.

To read in details of a new profile from the PC disk press the Read Profile from Disk button. The standard Windows file selection dialog box will be displayed and prompt the operator to select the file to upload. The software will default to looking for upload files in the directory C:\CRSTCHIC\PRESETS on the hard disk.

Once the file has been selected the operator is asked to confirm the selection and then the data in the chosen file is read into the Eclipse program where it is interpreted line-by-line and used to reprogram the preset loads and define a new Load Profile.

If the loadbank cannot recognise a line in the Load Profile Report file then the upload process halts with the unrecognised line being displayed. At this point the user may continue the upload having skipped this line or abort the remainder of the upload entirely. The offending line in the report file should be corrected and the upload attempted again to ensure the loadbank is fully reprogrammed.

Once the upload is complete the new Load Profile will be ready for use.

10.4 Running an Automatic Load Profile

Once a Load Profile has been entered into the Eclipse program, either by programming the profile from scratch or by uploading an existing Load Profile Report from the PC hard disk, the computer can be instructed to commence the sequencing of the load steps.

To run an Automatic Load Profile select the Run Load Profile option from the Command menu or press the  button on the toolbar. The dialog box shown below will be displayed.

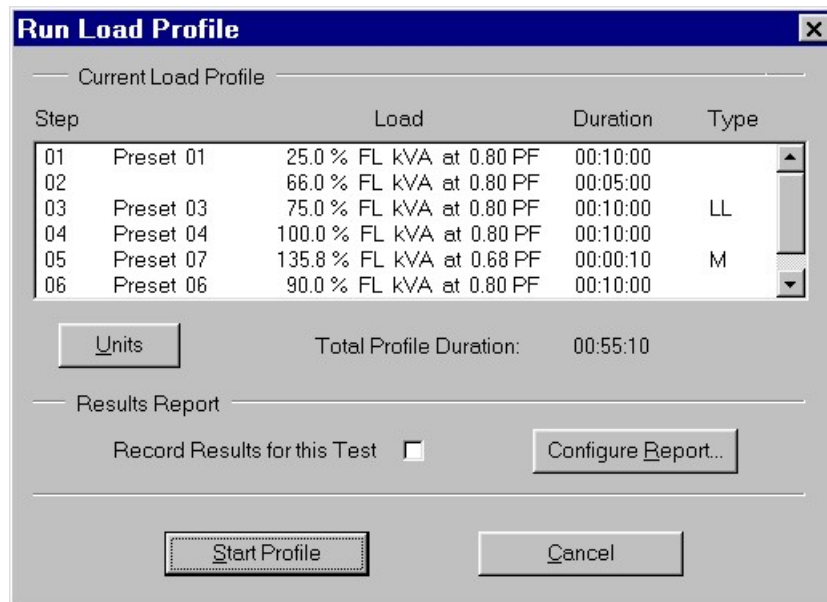

The operator can view the defined Load Profile in the list box at the top of the dialog box. The total running time for the entire profile is also displayed.

The operator may wish the instrumentation readings throughout the test to be recorded on the PC hard disk. To do this click on the checkbox in the Results Report area of the dialog box. For more information about the Results Report and its configuration see the Configuration Options section of this manual.

Once the Load Profile has been checked the operator can start the test by pressing the Start Profile button. The computer will examine the profile to ensure it does not contain any illegal loads and then, assuming no problems are found in the profile, apply the first load step. From this point the computer will control the sequencing of the load steps. The first load step in the profile will run for the specified duration. The next load step will then automatically be applied followed by each subsequent load step until the end of the defined profile is reached.

During the Automatic Load Profile mode the Instrumentation screen will be displayed as shown below.

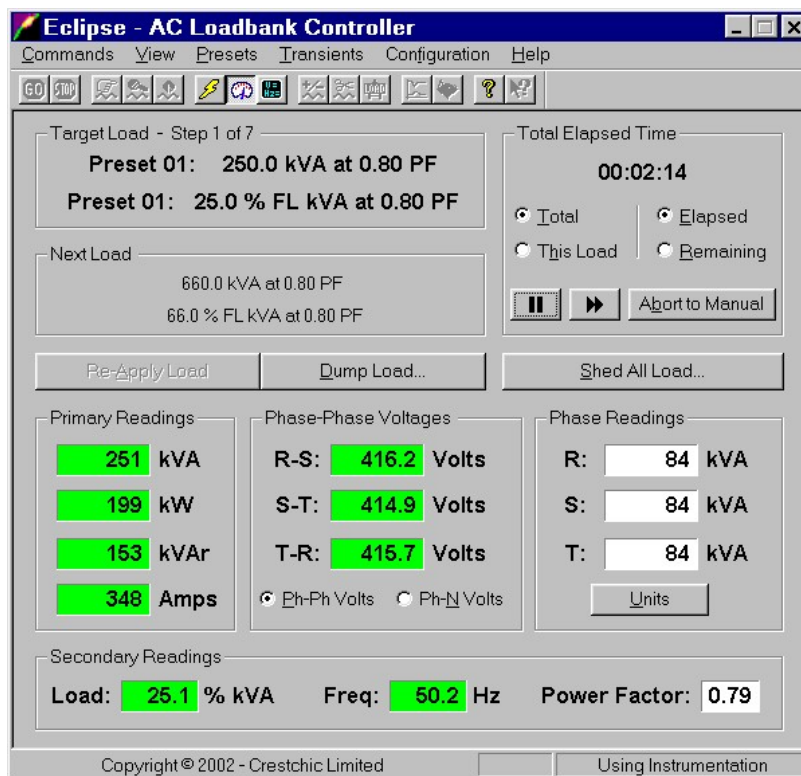

This display is similar to the standard instrumentation screen shown during Manual Loads mode. However it should be noted that the target load area now displays the number of the current load step that is applied and the three buttons in the Time area of the display are now enabled.

These buttons allow control of the Load Profile sequencing.

The  button is used to pause the sequencing of load steps by the computer. When it is pressed the currently applied load remains but no further load-changes will be performed until the button is released. The time indicator will flash to show that the load profile is in the paused state. The elapsed time will continue to increment but if the remaining time is displayed this will be found to have frozen. Once the pause button is released the remaining duration for the load step will elapse before the computer performs the next load-change.

The  button is used to advance the computer to the next load-step in the profile. Pressing this button will curtail the application of the currently applied load and cause the computer to apply the next load-step in the profile. Once pressed there will be a three-second delay before the load-change takes place.

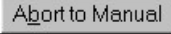
The  button causes the Load Profile to be aborted. The currently applied load will remain but the computer will perform no further load sequencing. The operator is now able to control the load as described in the Manual Loads section of this manual.

When in Automatic Load Profile mode the Load Dump facility is still available. To end the profile prematurely the Shed All Load button can be used to terminate the test.

It is not possible to directly perform Load Adjustment, Load Trimming or the Download of Transients when the loadbank is operating in this mode. To access any of these facilities the load sequencing must first be paused by pressing the  button. Once the operation is complete releasing the Pause button will continue the load profile.

Having completed the load profile the computer will remove the entire applied load and exit the Automatic Load Profile mode.

11.0 Transient Response

When working in Manual Loads mode or Automatic Load Profile modes the computer will record information about the excursion of the test supply's output frequency and voltage during each load-change. This transient response information can then be downloaded to the PC for storage and analysis.

11.1 Overview

At each load-change the loadbank computer will monitor and record information from the instrumentation's frequency transducer and one of its six voltage transducers. The user can select the voltage source monitored from one of the three phase-neutral voltage transducers or one of the three phase-phase voltage transducers.

During a load-change readings are taken from the two transducers 25 times every second. This continues for an operator-defined period of time, which can be between two and ten seconds after the load-change. If the next load-change occurs before the duration of the transient monitoring has been reached, the monitoring of the current transient is prematurely terminated and recording of the next load-change transient commences.

The loadbank computer has the capacity to store transient response data from the last twenty load-changes. This information is held in volatile memory and so it is important to realise that the transient data will be lost if the loadbank is powered-down before the transient details are downloaded for storage on the PC hard disk.

Downloaded transient response data is available for analysis using a spreadsheet program or graphical viewing and printing using the *Crestchic* TransView program.

Transient response data may be downloaded in one of two ways. If the operator presses the  button after a load-change this will automatically send the transient details recorded at the last load-change to the PC hard disk and then display them using the TransView application. Alternatively the Transient menu can be used to select which of the last twenty transients to download. The Transient Menu is described in detail later in this section.

Downloaded transient data is stored in the C:\CRSTCHIC\TRANS folder on the PC hard disk. The file naming convention used is described in the PC File Information appendix at the end of this manual. Transient response files, like the other types of file, are automatically deleted after a period of time unless they are moved from the folder or renamed.

The information in a transient response file is stored as standard text. There are several lines of header information and then the transducer data is written in the comma-separated variable (CSV) format recognised by most spreadsheets.

11.2 Download of Last Transient

To download the transient response data from the last load-change performed the operator should select the Download Last Transient option from the Transient menu or press the  button on the Eclipse toolbar.

When this is done the transient data will be transferred from the loadbank memory and stored as a file on the PC hard disk. The TransView program will then automatically be launched so that this data can be viewed graphically and printed out if required.

An example of the TransView output is shown below.

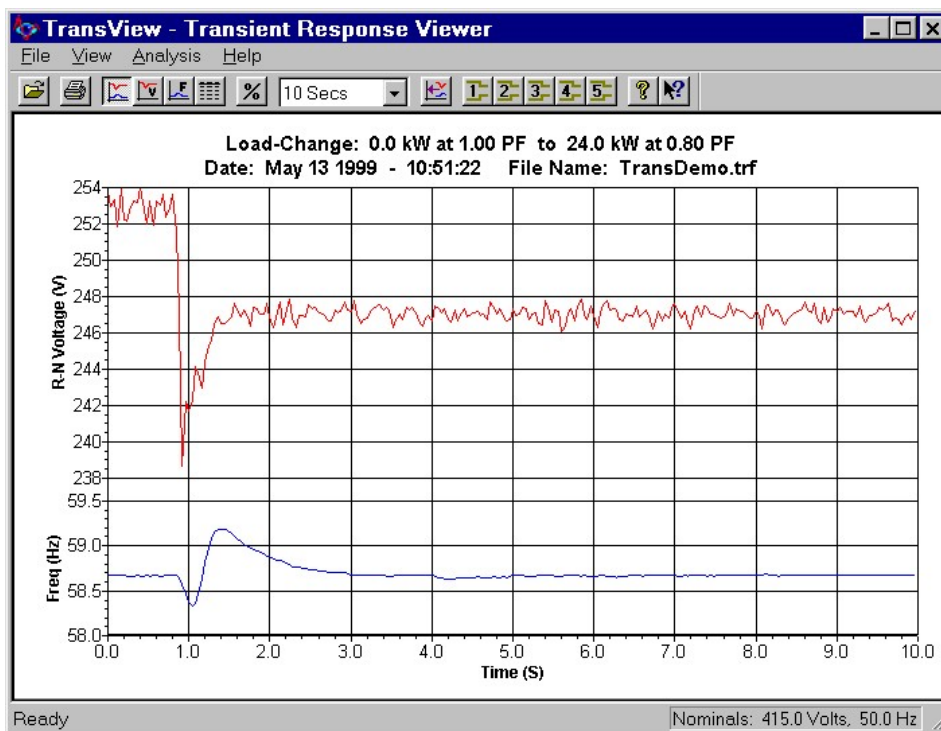

This is the simplest way to use the transient response facilities of the loadbank. More advanced features are available using options from the Transient menu.

11.3 Transient Menu Options

If it is required to analyse the transient response of the test supply during only a few of the last load-changes then the Transient Select dialog box can be displayed. This allows only certain load-change transients to be selected for downloaded.

This option may also be useful to allow the downloading of transient response data after the completion of a test run in Automatic Load Profile mode.

Choosing the Select Transient option on the Transients menu or pressing the  button on the toolbar will display the dialog box reproduced below.

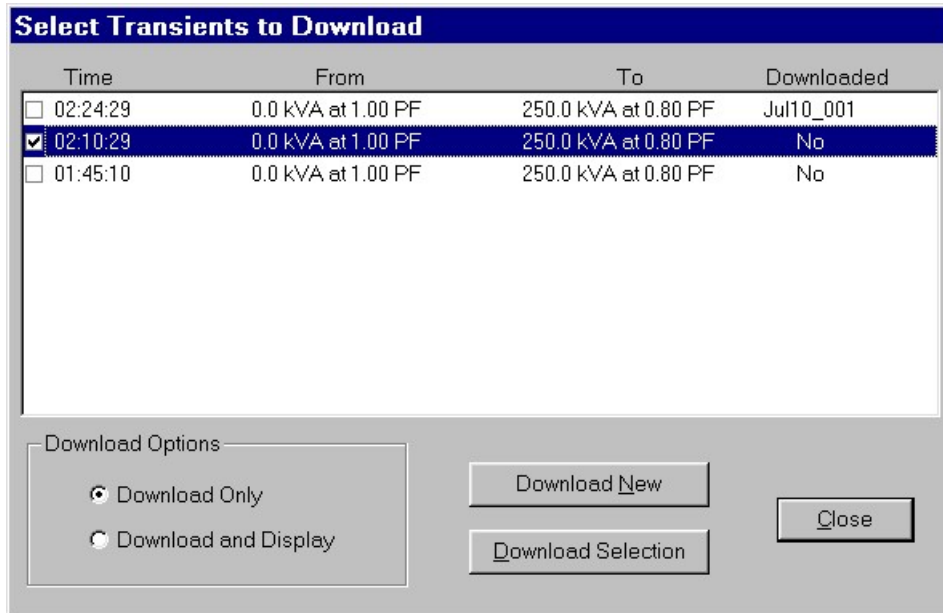

The Transient Select dialog box displays a list of the previous twenty load-changes with the most recent at the top of the list. The time and details of the load-change are shown for each transient and, if the information has already been downloaded, the filename assigned to that data is displayed.

To select specific transient details to download from the loadbank memory check the box on the left of the list box for each of the load-changes that are of interest. Then press the Download Selection button. The information from each selected load-change will be saved to a file on the PC hard disk.

If the download options have been set to Download and Display then, as each file is transferred, the TransView program will be launched to display the transient data graphically. If more than four files have been selected for download together then the download option should be set to Download Only. This prevents any memory shortage problems caused by multiple copies of TransView being launched.

Alternatively, if the Download New button is pressed the last twenty load-change transients recorded by the computer are examined. Any that have not already been downloaded are sent to the PC for storage on the hard disk. Again the TransView program will be launched if the appropriate option has been selected.

The Erase All Transients option on the Transients menu is used to clear any existing load-change transients from the computer memory. When this option is selected a warning message will be shown asking for confirmation before erasing the transient details. Ensure that any required load-change transients have been downloaded before confirming this option otherwise the data will be lost.

Note that this option only erases transient data in the loadbank computer memory. It does **not** delete any downloaded Transient Response Files from the PC hard disk. This option can be used to clear the loadbank memory of any existing transients before starting a test run in Automatic Load Profile mode.

11.4 Transient Configuration

Selecting the Transient Configuration option from the Transient menu will display the dialog box reproduced below.

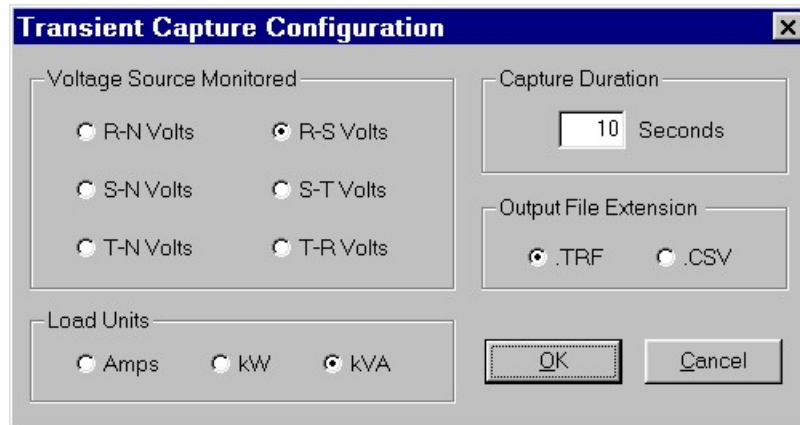

The Voltage Source Monitored area of the dialog box allows the user to select which of the six voltage sources to record during load-changes.

The Capture Duration is the period for which the voltage and frequency are monitored after a load-change. The maximum value is 10 seconds and the minimum value is 2 seconds.

The Load Units area of the Transient Configuration dialog lets the operator select the units in which the load-change is expressed when this information is downloaded to a Transient Response File.

Finally, the operator can select the file extension of a downloaded Transient Response File. If this is set to .CSV then the file will be automatically recognised and opened by most spreadsheets should it be desired to analyse the transient with one of these programs. Alternatively the .TRF file extension can be selected to allow the file to be viewed and printed graphically using the *Crestchic* TransView Transient Response Viewer program.

12.0 Configuration Options

Access to some of the loadbank configuration options may be password protected to prevent the alteration of data by unauthorised personnel. If this is the case enter the password when prompted by the display.

12.1 Test Supply Details

All the parameters needed to define the characteristics of the test supply are grouped together on a single dialog box. The generator ratings may be entered as part of the loadbank start-up sequence or at any time from the Configuration Menu.

The Test Supply Configuration is the first option that should be accessed when setting up the loadbank to test a piece of equipment, as this is where the nominal output of the power source is defined. The values entered here will define the limits of operation and the actual size of load applied when working with preset loads and in Search Mode.

To display the Test Supply details select the Test Supply option from the Configuration menu or press the  button on the application toolbar. The dialog box reproduced below will be shown.

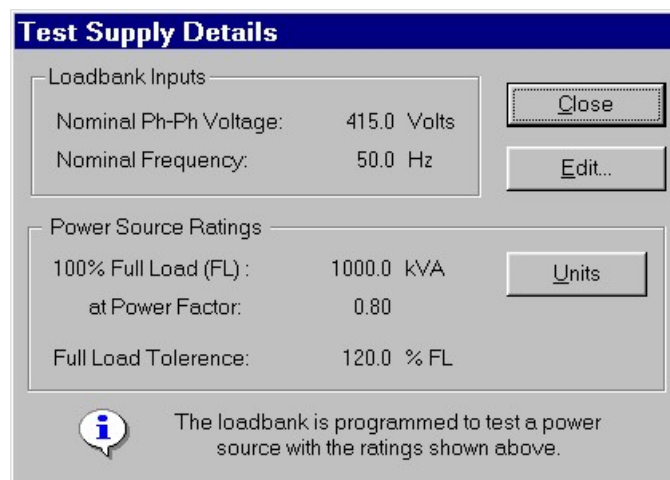

Pressing the Edit button allows alterations to be made to the Test Supply parameters. The equivalent full load can be displayed in different units by pressing the Units button.

The loadbank software uses the values entered at the Test Supply Specification dialog box to protect the equipment under tested from being subjected to excessive loads. Therefore it is vital to ensure that the test supply is correctly specified each time the loadbank is used.

The loadbank input values allow the nominal voltage and frequency applied to the loadbank bus bars to be defined. The values entered are checked to ensure they are within the loadbank operating limits before being accepted by the system. Do **not** exceed 440V when using reactive loads with a 50 Hz supply frequency.

The nominal full-load power or current that the test supply is capable of supplying must be specified. It can be entered as an Amp, kW or kVA value at a power factor. The 100% load power is fundamental to the operation of the loadbank as this value is used to provide overload protection in all operating modes. Preset loads are also expressed as a percentage of this value and when trimming a load, or in Search Mode, the load is increased or decreased by a percentage of this figure.

If the value is changed then any Learned Loads associated with a preset load will be erased, as they will no longer be valid.

The Maximum Full Load Tolerance parameter should be set to the highest rating that the Test Supply will have to supply continuously – for example 110% if overload testing is to be carried out. It can also limit the size of load applied. For example, if it were set to 50% then the loadbank would only permit loads up to half of the generators load-rating to be applied. Setting this variable prevents loads being applied greater than this specified tolerance in all operating modes.

Once the test supply has been full specified pressing the Close button will dismiss the Test Supply Details dialog box.

12.2 Results Report Configuration

This option allows the parameters used for the Results Report to be specified. Select the Results Report option from the Configuration menu to display the dialog box shown below.

The screenshot shows a dialog box titled "Results Report Configuration". It has a blue title bar with a close button (X). The dialog is divided into several sections:

- Report Type:** Three radio buttons are present: "Text Format Report" (selected), "Standard", and "Full". Below these is a "CSV Format Report" option with a "Select" button.
- Results Output Interval:** A text box contains the number "5", followed by the text "Seconds".
- Report Units:** Three radio buttons are present: "Amps", "kW" (selected), and "kVA".
- Report Text:** Two text boxes are present: "Title Text" containing "40kW 3-ph Software Dev Test Profile" and "End Text" containing "Powerfield FEPS Production Test Facility".

At the bottom of the dialog are three buttons: "Use Default Text", "OK", and "Cancel".

The parameters set up in this dialog box are retained in the loadbanks non-volatile memory and so do not have to be entered every time the loadbank is used.

When the loadbank is on-load the computer will output measured values from the instrumentation at regular intervals. The Results Output Interval allows the time between these outputs to be defined in seconds.

The parameters on a Results Report can be output in a choice of two layouts, either as formatted text or in comma-separated variables (CSV) format. The latter format can be read by most spreadsheet applications (such as *Microsoft Excel*) thus allowing the results of a test to be loaded into such a program for manipulation and analysis.

When CSV format is selected for a Results Report the operator is given the opportunity to select which parameters are to be output to the report file. To do this press the Select button and then mark the parameters of interest in the checkbox on the displayed dialog box. These will then be output to the CSV file at the selected interval.

When the Results Report is selected to be output in Text format the other options on the configuration dialog are applicable and will be available for use. A description of these Text mode options is given below.

The Report Units area enables the setting of the units that target loads are expressed in on the Results Report. Target loads can be shown in Amps, kW or kVA. The units used for target loads on the Results Report are independent of the currently selected units on the Instrumentation display.

The Report Type area of the dialog box is where the operator can select one of the two available report types. The standard report type will record the instrumentation readings for the total load on one line each time the Results Output Interval expires. A full report will record the readings for the total load on the first line and then the instrumentation readings for each phase on the three following lines every time the interval expires. The type of report to be produced is left to the operator and will depend upon the amount of information required.

The Report Text allows a title line and an end-of-test message to be entered. The title line is printed at the start of the Results Report. This can be customised to the users' requirements. For example, this could be name of the installation being tested or the company name. The End Text is the line that will be printed at the bottom of a test report. This could be set to display the name of the engineer conducting the test or a general message.

Pressing the Use Default Text button will reset the title and end-of-test lines to their default values of "Test Results" and "Engineers Signature:" respectively.

12.3 Loadbank Time

Choosing the Loadbank Time option from the Configuration Menu will display the dialog box shown below allowing the date and time in the loadbank processor to be set.

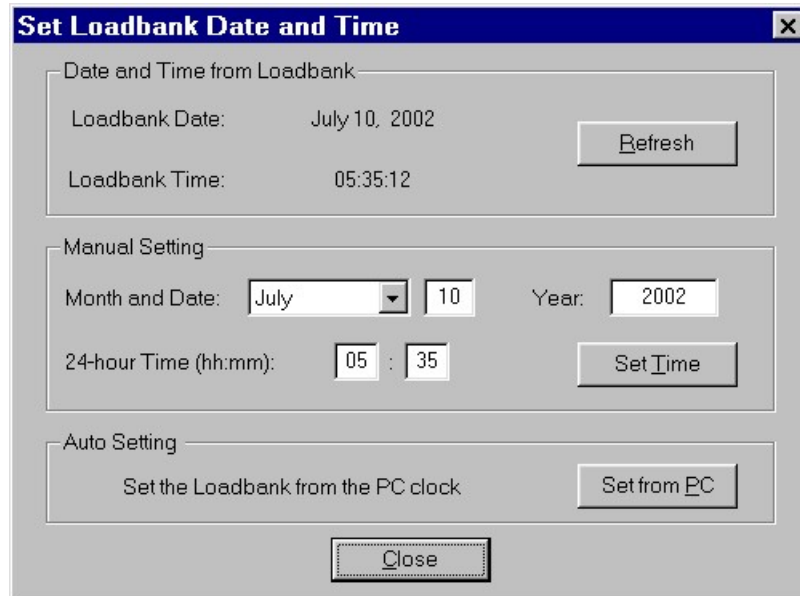

The top area of the dialog box shows the date and time information read from the loadbank processors clock. The centre section of the dialog box allows the operator to manually enter a new date and time. The processor clock is then set using this information when the Set Time button is pressed.

Alternatively, if the date and time are correct in the PC the loadbank clock can be set automatically using this information by pressing the Set from PC button.

In all cases the loadbank computer stores the entered time. When the loadbank is not powered its processor module retains this information using its on-board re-chargeable battery.

12.4 User Pass-code

This option allows the pass-code used to access some of the loadbank Configuration Options to be altered. The password is a numeric value. If zero is selected as a password then access to the Configuration Options is not protected – otherwise the pass-code will be requested from the operator the first time one of the restricted-access Configuration Options is selected.

Once the pass-code has been successfully entered then the operator will be able to continue accessing the restricted-access options until the Eclipse application is closed. When Eclipse is next used the User pass-code will have to be re-entered when the operator first attempts to select a restricted-access option.

Care should be taken when changing the pass-code number to ensure it is memorised. This will prevent the operator from being locked-out of the Configuration Options.

12.5 Communications Port Selection

This option is selected by choosing the Com Port entry on the Configuration menu. The dialog box shown below will be displayed.

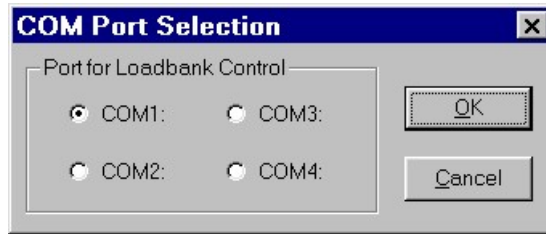

This dialog is used to select the serial communication port used to communicate with the loadbank. For more information on the serial ports fitted to their PC, the operator should consult the hardware documentation supplied when they purchased their computer.

12.6 Report Auto Deletion

The dialog box shown below is displayed when the operator selects the Report Auto-Delete option from the Configuration menu.

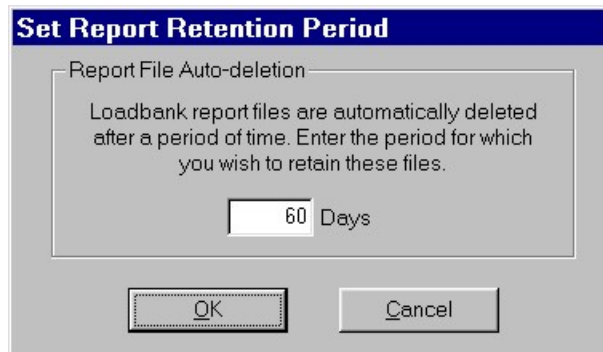

Using this option the operator can specify how long the report files generated by the Eclipse software are to be retained on disk before they are automatically deleted.

Note that only files with the Eclipse file-naming convention will be affected by this mechanism. For more details on working with PC files see the PC File Information section appended at the end of this manual.

13.0 Loadbank Shutdown

Once all tests have been completed the loadbank may be shut down. Selecting the Shutdown Loadbank option on the Commands Menu or pressing the  button on the application toolbar will start the shutdown sequence.

The loadbank will run for up to four minutes with no load applied to ensure that the system is adequately cooled before the fans are turned off. The actual duration of the shutdown sequence is variable as the four minutes cooling time is taken from when the loadbank was last on-load. During this time the screen shown below will be displayed.

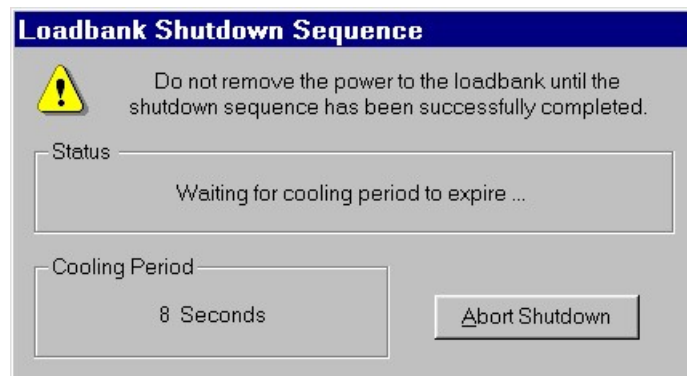

After the cooling period has expired the loadbank fans will stop and the Instrumentation display will be replaced by the Eclipse splash-screen. The power supplies to the loadbank can now be removed.

It is important that the shutdown sequence is **always** run at the end of testing, before the power is removed.

Selecting the Exit option from the Commands menu or clicking the close button in the application title bar can now be used to terminate the Eclipse program.

14.0 Miscellaneous Options

This section of the manual covers options in the Eclipse software that have not been discussed elsewhere.

14.1 Toolbar and Status bar Visibility

The application toolbar and status bar can be displayed or hidden by selecting the Toolbar or Status Bar options in the View menu.

14.2 Loadbank Statistics

When the Loadbank Statistics option is selected from the View menu the dialog box shown below will be displayed.

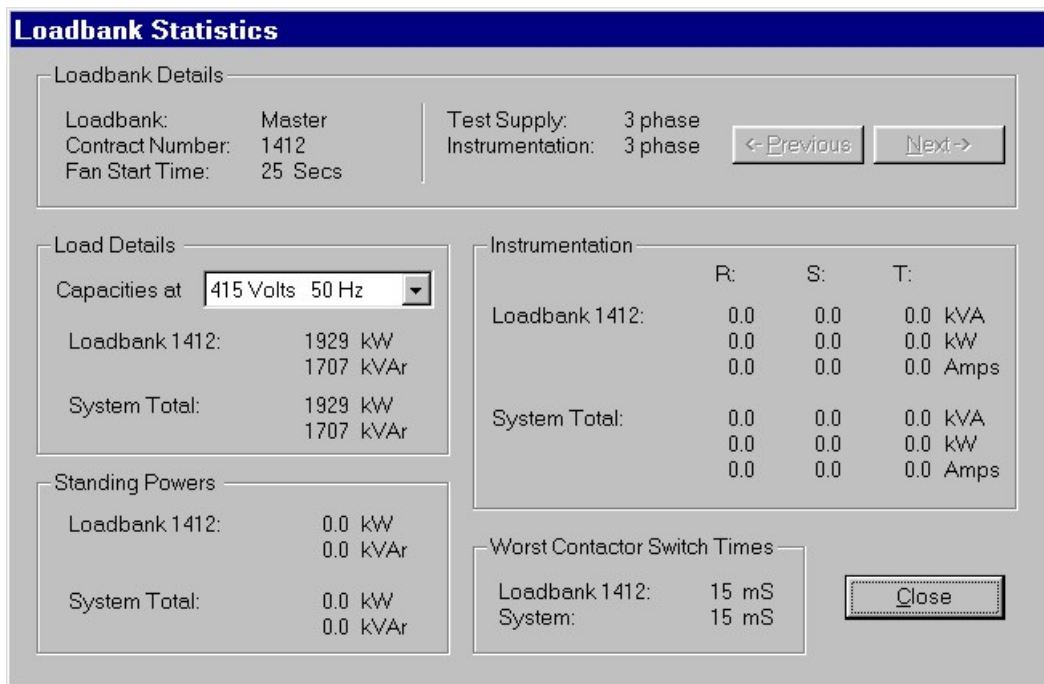

This dialog box gives information about the current operating status of the loadbank.

If the loadbank is operating in multiple-mode then information about each loadbank comprising the system can be displayed by pressing the Previous and Next buttons.

The information on this display is mainly to aid Crestchic personnel should any problems be encountered when using the loadbanks.

14.3 Transducer Values

To display a list of the raw data values from the loadbank instrumentation transducers select the Transducer Values option from the View menu. This will result in the display below being shown.

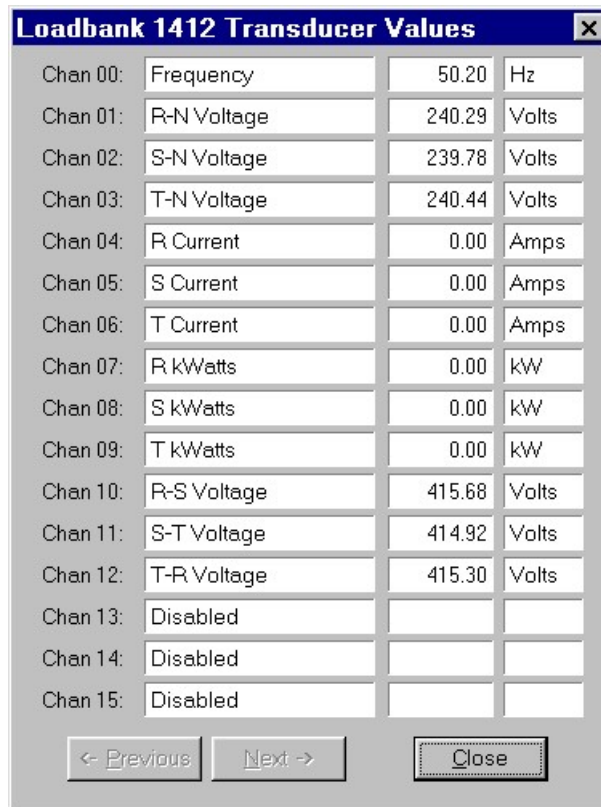

Channel	Measurement	Value	Unit
Chan 00:	Frequency	50.20	Hz
Chan 01:	R-N Voltage	240.29	Volts
Chan 02:	S-N Voltage	239.78	Volts
Chan 03:	T-N Voltage	240.44	Volts
Chan 04:	R Current	0.00	Amps
Chan 05:	S Current	0.00	Amps
Chan 06:	T Current	0.00	Amps
Chan 07:	R kWatts	0.00	kW
Chan 08:	S kWatts	0.00	kW
Chan 09:	T kWatts	0.00	kW
Chan 10:	R-S Voltage	415.68	Volts
Chan 11:	S-T Voltage	414.92	Volts
Chan 12:	T-R Voltage	415.30	Volts
Chan 13:	Disabled		
Chan 14:	Disabled		
Chan 15:	Disabled		

Again this option is mainly for the benefit of *Crestchic* personnel during the diagnosis of any problems encountered when operating the loadbank.

14.4 System Event Log

To open a window displaying the system event log select the System Event Log option from the View menu.

The information displayed in this window will be a list of the last 100 events that have affected the loadbank. This can include status information and operator actions.

The information in this log may be useful if a loadbank operating limit error occurs. Examining the log will give information about the instrumentation values read by the loadbank and so should point to the cause of the reported error.

14.5 Communications Errors

To display a count of the errors experienced on the serial communications link between the PC and the loadbank select the PC to Loadbank Errors option on the View menu. The following dialog box will be displayed.

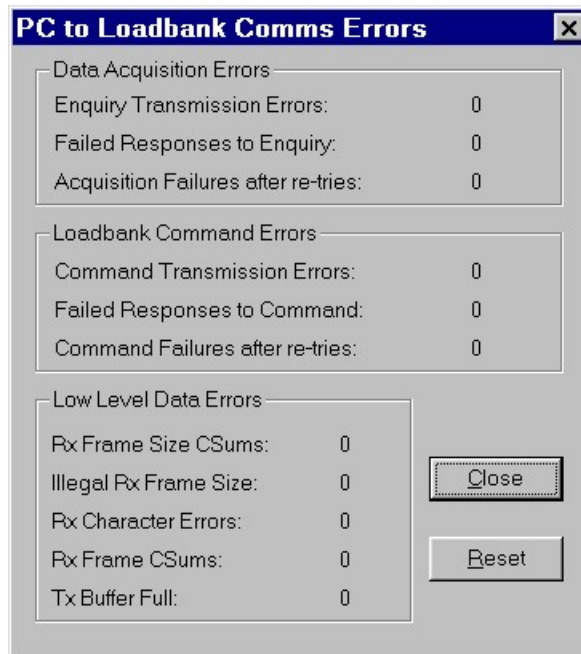

It is to be expected that some errors will occur on the communications link and the system software has been written to incorporate error recovery techniques to provide a robust and fault-tolerant communications protocol. Therefore the operator should not be alarmed if some of the error counters show non-zero values when this dialog box is displayed.

When operating in multiple loadbank mode the number of errors that have occurred on the communications link between the master and slave loadbanks can be seen by selecting the Inter-Loadbank Errors option from View menu.







A dialog box similar to that shown above will be displayed. Again it is anticipated that some errors will be encountered and so the presence on non-zero values should be expected. The inter-module communications protocol is designed to cope with data transfer errors.

Finally, when using a loadbank that incorporates a *Crestchic* Solar Processor module, it will be possible to view the communication errors encountered by this processor's IO-Bus by selecting the IO-Bus Errors option from the View menu. A dialog box showing the error counts will be displayed and again a few indicated errors should not give cause for concern.

Appendix A Summary of Menu Options

This appendix gives a brief summary of all the options available on the Eclipse menu bar

A.1 Command Menu

Menu Option	Toolbar	Description
Start Loadbank		Run the loadbank start-up sequence
Shutdown Loadbank		Perform the loadbank shutdown sequence
Set-up Manual Load		Prepare a manual load for application
Search Mode		Enter the mode where load is manipulated interactively by the operator
Run Load Profile		Start the mode in which the computer sequences each load-step in the load profile automatically
Auto Load Adjust		Automatically adjust the applied load to the target load
Load Trim Mode		Allow the operator to manually adjust the applied load
Establish Comms		Transfers the loadbank calibration data to the PC but does not run the start-up sequence
Exit		Quit the Eclipse application

A.2 View Menu



Menu Option	Toolbar	Description
Analogue Instruments 1		Show analogue meters on the Instrumentation display
Analogue Instruments 2		Show an alternative layout for the analogue meters on the Instrumentation display
Digital Instruments		Show digital readings on the Instrumentation display
Toolbar		Set the visibility of the application toolbar
Status Bar		Set the visibility of the application status bar
Loadbank Statistics		Display configuration data about the loadbank

Transducer Values		Display the raw transducer readings from the instrumentation
PC to Loadbank Errors		Display a count of the errors encountered on the PC to loadbank communication link
Inter-Loadbank Errors		Display a count of the errors encountered on the communications link between multiple loadbanks
IO-Bus Errors		Display a count of the errors encountered on the IO-Bus of a Solar SBC. Only applicable to loadbanks fitted with this type of processor module.
System Event Log		Display a list of the last 100 events experienced by the loadbank



A.3 Presets Menu

Menu Option	Toolbar	Description
Program Preset Loads		Define the load parameters for a preset load
Set M-Test Load		Define the M-Load parameters
Learn Load		Store the applied load details with the preset load information
Create/Edit Load-Profile		Set-up or edit a list of load-steps to be sequenced by the computer
Read Load-Profile		Read an existing Load Profile from the PC hard disk
Write Load-Profile		Save the Load Profile in memory to a file on the PC hard disk
Apply Stored Node		Apply one of the seven stored nodes in Search Mode
Store Node		Save details of the applied load in one of the seven Stored Nodes used by Search mode

A.4 Transient Menu

Menu Option	Toolbar	Description
Download Last Transient		Transfer transient response data from last load-change to the PC and automatically display it using TransView
Select Transient		Select a number of transients for download to the PC
Erase All Transients		Clear the loadbank memory of all previous transient response data
Transient Configuration		Set-up the parameters used in the Transient Response functions

A.5 Configuration Menu

Menu Option	Toolbar	Description
Test Supply		Define the ratings for the test supply
Use Instrument Values		Use measured values in load calculations
Use Nominal Values		Use test supply nominal ratings in load calculations
Results Report		Define the parameters for the Results Report
Loadbank Time		Set the date and time for the loadbank processor clock
User Passcode		Set the pass-code used to access restricted menu options
Comms Port		Select the PC serial port to use for loadbank control
Report Auto-Delete		Set the number of days for which report files are to be retained

A.6 Help Menu

Menu Option	Toolbar	Description
Help Topics		Display on-line documentation for Eclipse
About Eclipse		Display release and copyright information

Appendix B PC File Information

Using the Eclipse software it is possible to write Test Results and Load Profile Reports to a file on the computer hard disk. It is also possible to transfer a Load Profile list from the hard disk on the PC to the loadbank.

B.1 Output to a PC

There are several advantages to being able to output Results Reports to a PC hard disk. Firstly, once the generator tests are complete, the PC can be taken away from the generator facility and the results analysed and printed in the comfort of an office environment. Secondly, as the file is resident on a computer hard disk it can be easily incorporated into any Generator Test Report written by the Test Engineer using a word processor.

The filename that is automatically assigned to a report stored on disk is made up of three parts. The first five characters give the month and day that the file was created upon. For this to be meaningful the clock in the PC must be set to the correct date and time.

The second part of the filename is a three-digit number that will increment from 001 to 999, as each new printout is stored on the hard disk. Thus it is possible to store up to nine hundred and ninety-nine different Result Reports each day if required. Finally the file extension denotes the type of printout that the file holds.

The table below summarises the different file types it is possible to output to a PC hard disk.

File Type	Hard Disk Location	File Extension
Test Results Report	C:\CRSTCHIC\RESULTS	.TST .CSV
Load Profile Report	C:\CRSTCHIC\PRESETS	.PRE
Calibration Report	C:\CRSTCHIC\CALIB	.CAL
Loadbank Log Report	C:\CRSTCHIC\LOGS	.LLG
Transient Response File	C:\CRSTCHIC\TRANS	.CSV .TRF

Any report files with a name in the format described above are automatically deleted from the PC hard disk a certain time after they are created. This is to stop the hard disk from becoming filled with old reports.

If it is desired that a certain report file be kept then, to prevent its automatic deletion, it can either be renamed and/or copied to a different directory on the PC at any time before the auto-deletion period expires. The operator can specify this period in the Configuration options.

All reports output to the PC are stored as standard text files and can be viewed or annotated using any standard text editor or word processor such as **Notepad** or **WordPad** when using *Microsoft Windows*.

B.2 Uploading from a PC

It is also possible to transfer data from the PC hard disk into the Eclipse software. This process is known as uploading. The main type of file that the operator may wish to upload is a Load Profile Report. This file contains information on preset loads and a list of load-steps that must be performed to test a specific piece of equipment.

As the Load Profile Report file is a standard text file this means that a new test profile can be prepared away from the loadbank, e.g. in an office environment, on any PC and then upload to the loadbank at the start of the test.

It should be noted that the file to be uploaded should only be a standard text file. This means that files saved in the native mode of full-feature word processors such as MS **Word** or **WordPerfect** cannot be uploaded as the files produced by these applications are not standard text and contain additional formatting information that will not be recognised when uploaded. If using one of these packages to generate a Load Profile Report file for upload ensure the file is saved in text-only mode. Alternatively, keep to using a simple text editor such as **Notepad** or **WordPad** in text-only mode.

As the loadbank computer has to interpret each line of the file it is important that the format of the Load Profile Report file is strictly followed to allow the computer to recognise each line.

If a new load profile is being created for upload, that file must comply with the strict formatting criteria necessary to allow a computer to interpret the file. It is often easier to generate a Load Profile Report file from the loadbank and use this as a template for editing rather than try to create the report file from scratch.

An example of a Load Profile Report is shown on the next page. This is the type of report that is produced for a resistive/reactive loadbank. The format of the report for a resistive-only loadbank is slightly different, as it is not possible to perform M-Tests on this type of unit.

When editing a Load Profile Report for upload the following information may be helpful:

- any line that starts with a slash, asterisk or full-stop character (/, * or .) is considered a comment and the remainder of the line is ignored by the computer
- when specifying “Use of Measured Values” the computer will recognise the words Enabled or Disabled

- when entering the Test Report title and signature lines the character strings to be printed must be delimited by single quote characters, e.g. 'This is a string'. The maximum length for these two text lines is forty characters
- all other entries when editing a Load Profile Report template file are numeric or units (kW, kVA, Volts etc.)

Finally, when renaming Load Profile Report files to prevent automatic deletion or when creating a new upload file, it is important that the file extension of .PRE is maintained. Otherwise the PC will not identify the file as a Load Profile Report file and it will not appear on the file selection screen as available for uploading.

An example of a Load Profile Report file is shown below.

```
// -----  
//                               LOADBANK PRESETS REPORT  
//  
//       Printout of Preset Load Details and Load Profile  
//       Information for Crestchic Loadbank - Contract Number 1412  
//  
//       Eclipse A.C. Load Control System Software  
//       Copyright (C) 2002 - Crestchic Ltd  
//  
//       Date of Report : July 10, 2002 - 06:56  
// -----  
  
//       Generator Parameters  
//  
Nominal Ratings      =      415.000000 Volts      50.000000 Hz  
Full Load Output    =      1000.000000 kVA      at 0.800000 PF  
Full Load Tolerance =      120.000000 %  
Use of Measured Values =      Enabled  
  
//       Units in which Preset, M-Load and Profile Step  
//       percentages are expressed  
//  
Load Programming Units = kVA  
  
//       M-Test Load Details  
//  
M-Load =      50.000000 % FL at 0.400000 PF
```

```

//      Details of Primary Preset Base Loads
//
.
.      % Full Load   Power Factor   Plus M-Test   Duration
.      -----
Preset 01 :    25.000000    0.800000        No    00:10:00
Preset 02 :    50.000000    0.800000        No    00:10:00
Preset 03 :    75.000000    0.800000        No    00:10:00
Preset 04 :   100.000000    0.800000        No    00:10:00
Preset 05 :   110.000000    0.800000        No    00:10:00
Preset 06 :    90.000000    0.800000        No    00:10:00
Preset 07 :    90.000000    0.800000        Yes   00:00:10
Preset 08 :     0.000000    1.000000        No    00:00:00
Preset 09 :     0.000000    1.000000        No    00:00:00
Preset 10 :     0.000000    1.000000        No    00:00:00
Preset 11 :     0.000000    1.000000        No    00:00:00
Preset 12 :     0.000000    1.000000        No    00:00:00
Preset 13 :     0.000000    1.000000        No    00:00:00
Preset 14 :     0.000000    1.000000        No    00:00:00
Preset 15 :     0.000000    1.000000        No    00:00:00
Preset 16 :     0.000000    1.000000        No    00:00:00
Preset 17 :     0.000000    1.000000        No    00:00:00
Preset 18 :     0.000000    1.000000        No    00:00:00
Preset 19 :     0.000000    1.000000        No    00:00:00
Preset 20 :     0.000000    1.000000        No    00:00:00

//      Details of Load Profile
//
.
.      % Full Load   Power Factor   Plus M-Test   Duration
.      -----
Step 001 :  Preset 01    25.000000    0.800000        No    00:10:00
Step 002 :                66.000000    0.800000        No    00:05:00
Step 003 :  Preset 03    75.000000    0.800000        No    00:10:00
Step 004 :  Preset 04   100.000000    0.800000        No    00:10:00
Step 005 :  Preset 07    90.000000    0.800000        Yes   00:00:10
Step 006 :  Preset 06    90.000000    0.800000        No    00:10:00
Step 007 :  Preset 02    50.000000    0.800000        No    00:10:00

//      Results Report Parameters
//
Results Output Period = 30 Seconds
Results Load Units    = kVA
Full Results Report   = Enabled
Results Title Line    = 'Test Results Report'
Results Signature Line = 'Engineers Signature: _____'

//      Transient Capture Parameters
//
Monitored Parameter = 'R-S Voltage'
Capture Duration    = 10 Seconds
Load-Change Units   = kVA

//      End of Preset Report

```

Appendix C Quick Start Guide

This section is intended as an introduction to the essential procedures to get an Eclipse loadbank up and running to a level where it can be used to apply loads either manually or sequenced by the computer. It should not be regarded as a substitute for reading the full manual. Instead this section should be used in conjunction with the full manual, which gives greater detail on the basic operating modes together with information about the advanced features available from the computer control system.

C.1 Setting Up

The PC should be connected to the Control Terminal socket on the loadbank using any necessary extension cables.

If there is more than one loadbank being used then they should be daisy-chained to the first loadbank using the communications cables supplied for this purpose. Each loadbank is fitted with two inter-module connection ports (A & B) and either or both ports may be used to form the chain.

The cooling fans and control system require a power supply to operate. This supply can be derived from the equipment on test or a separate independent source. Check the ratings plate on the specific loadbank(s) being used for information about the voltage and frequency range that will be suitable for the control system supply. It is preferable to run the loadbank(s) from a stable external power supply where possible.

The loadbank switches should be set appropriately:

Internal/Off/External	Set to select power source for loadbank control system
Voltage Selector	Set to the value of the selected control system power source
Emergency Stop	Pulled Out

Switch the test-supply through to the loadbank(s) and turn on the auxiliary power supply if one is being used.

Turn on the PC and allow it to proceed through its start-up sequence until the Windows desktop is displayed. To start the Eclipse loadbank control program double-click the Eclipse icon on the desktop.

C.2 Start Up

To start using the loadbank press the **GO** button on the Eclipse toolbar. This will cause the loadbank to perform its start-up sequence. Read the display and respond to the prompts to work through this sequence.

During the start-up sequence the display will show the total capacity of the loadbanks comprising the system and their operating limits. The loadbank protection system will automatically reject load if these values are exceeded. If the limits are not suitable for the required testing please contact *Crestchic*.

At a certain stage in the start-up sequence the operator will be asked to specify the parameters for the supply being tested. It is important that this information is correctly entered, as it is these values that the loadbank software uses to protect the supply from overload. The generator ratings screen is shown below.

Loadbank Startup Sequence

Loadbank Inputs

Nominal Ph-Ph Voltage: 415.0 Volts

Nominal Frequency: 50.0 Hz

Edit..

Power Source Ratings

100% Full Load (FL) : 1000.0 kVA

at Power Factor: 0.80

Full Load Tolerance: 140.0 % FL

Units

i The loadbank is programmed to test a power source with the ratings shown above.

< Back Next >

Press the Units button to see the load expressed in Amps, kW or kVA. Press the Edit button to edit the test supply parameters. Once the test supply has been correctly specified then press Next button to continue the start-up sequence.

If there are any Learned Loads in the computer memory the display will show a screen asking if these are still valid or if they should be erased. Normally at the start of a new job any existing Learned Loads should be erased.

The start-up sequence gives the option of starting the cooling fans. If this option is chosen there will be a short delay whilst each of the fans in the loadbank(s) starts in progression.

This completes the start-up sequence and the Instrumentation screen is displayed.

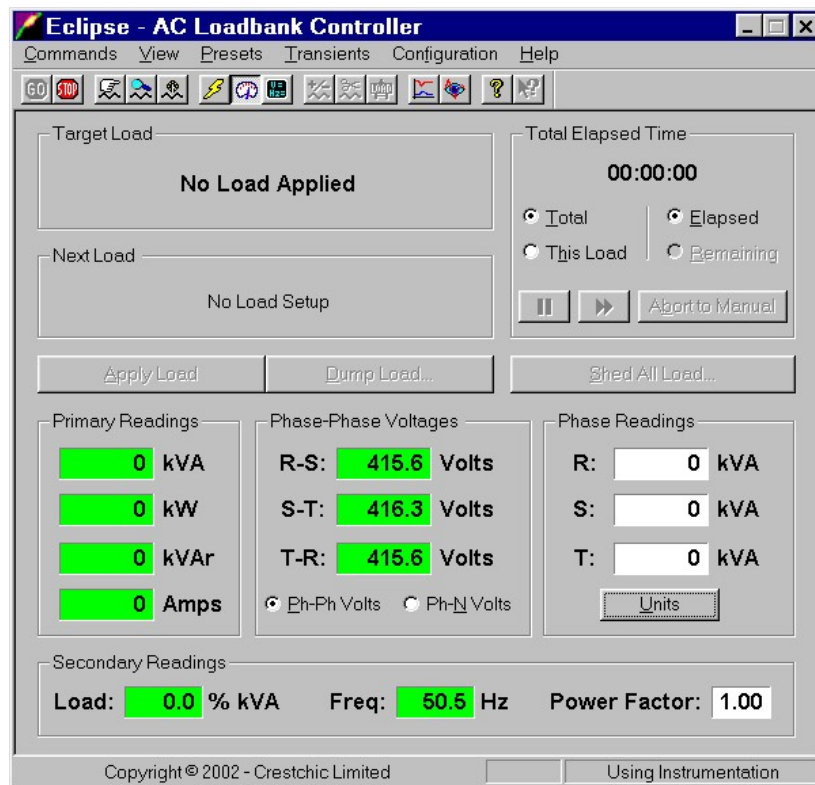

C.3 Manual Loads

This mode allows loads to be directly entered by the operator. Press the  button on the toolbar to enter this mode. The screen will prompt for the size of load that is required.

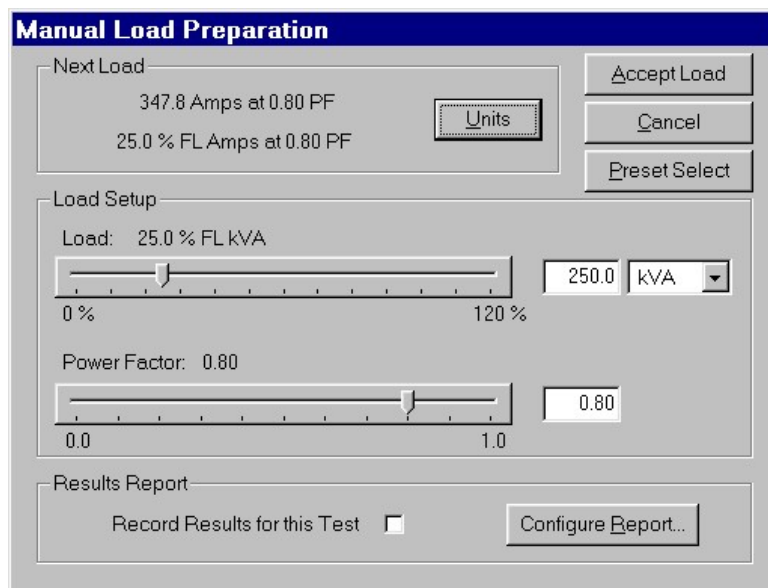

To change the units in which the load is entered select the required item (Amps, kW or kVA) from the drop-down list box. Type the load magnitude and power factor into the edit boxes or use the slider controls to set these values. Once the load has been correctly specified press the Accept Load button to confirm the load details.

The screen will now display the instrumentation values but the new load will not yet have been applied. When ready press the Apply Load button to use the prepared load.

To change the load press the  button and enter the new load details as before. When preparing the next load to apply it is possible to choose one of the preset loads stored in the loadbank. Up to twenty loads can be memorised by the loadbank. These are programmed from the Presets menu and details of how this can be done are covered in a later sub-section of this appendix.

Any of these preset loads can be applied at the operators command. To display a list of the available preset load press the Preset Select button on the Load Preparation dialog box. The dialog will then change to that show below.

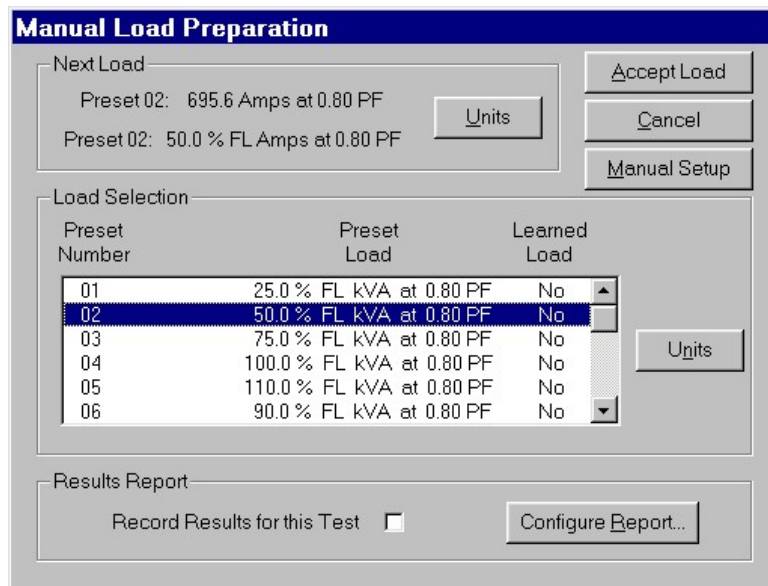

Select one of the presets from those displayed in the list box and then press the Accept Load button. The Load Preparation dialog box will disappear and the preset load will be ready for application. To apply the preset load press the Apply Load button again.

Press the Shed All Load button to remove the entire applied load and finish the test.

When on-load a Load Adjustment feature is available by pressing the  button. This will adjust the applied load as accurately as possible to meet the requested target load.

A trim feature is also available to allow the operator to manually adjust the applied load. Press the  button to commence the trim function.

The Instrumentation screen will display additional load manipulation controls in the Target Load area of the screen.

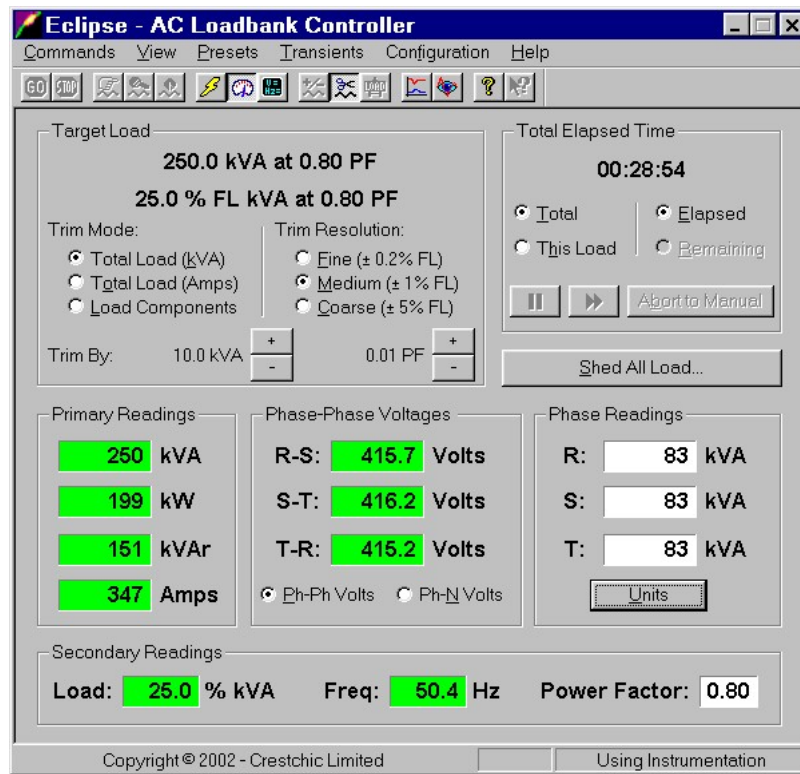

The trim applied depends upon the selected Trim Mode and Resolution that the system is currently operating in. The amount by which the applied load will be modified is shown at the bottom of the Target Load area. To change the load by the indicated amount press the appropriate **+** or **-** button



If the applied load is from the list of presets and either the automatic Load Adjustment or the Trim facility has been used to adjust it to the required value, the modified load can be learnt by pressing the **LOAD** button. If that preset is called up again the loadbank will not calculate the load elements required but will switch in the adjusted load that was previously learnt.

A summary of the buttons in Manual Loads mode is given below:

button	Specify new load
Shed All Load button	Removes applied load and exits the Manual Loads mode (double-stroke)
Dump Load button	Reduce applied load by 25% (double-stroke)
button	Automatic Load Adjustment
button	Enable Load Trimming facility
button	Store the adjusted load for a preset (double-stroke)
Units button	Display load in different units (Amps, kW, kVA)

C.4 Search Mode



This mode allows free adjustment of the applied load and power factor using the Load Trimming feature described in the previous sub-section.

This mode is selected by pressing the  button. It immediately changes the Instrumentation screen to display the additional load manipulation controls. The load can be modified by using the  and  buttons as described previously.

A specific load condition (node) can be stored for future retrieval. When running at the desired load select the Store Node option from the Presets menu. The list of seven nodes that can be stored will be displayed. Follow the screen prompts to store the currently applied load in the desired node location. Previously stored nodes will be overwritten with the new load details.

To apply a previously stored node choose the Apply Stored Node option from the Presets menu and select the load from the list of seven nodes. This process can be repeated as required.

A summary of the buttons in Search Mode is given below:

 button	Enter Search Mode
Shed All Load button	Removes applied load and exits the Search Mode (double-stroke)
 button	Automatic Load Adjustment
Units button	Display load in different units (Amps, kW, kVA)

C.5 Automatic Load Profile

This mode allows a sequence of preset loads to be applied under control of the loadbank computer for the specified duration of each load. Details of how this Load Profile is defined will be given later in this appendix.

Pressing the  button on the toolbar enters the Automatic Presets Mode.

A dialog box giving details of the Load Profile is displayed and the operator should check this to ensure the profile will perform the desired test. If the operator is satisfied with the profile details then pressing the Start Profile button will start the test.

This dialog box is reproduced below.

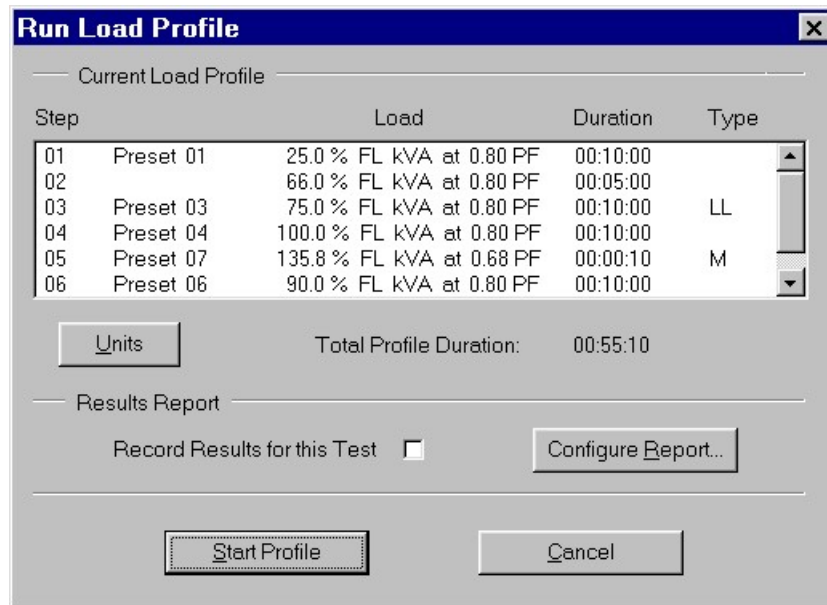

The computer will work through the list of load-steps in the Load Profile applying each load sequentially for the specified duration.

Once all the load-steps in the sequence have been applied for their specified durations all load will be shed and the Automatic Load Profile Mode will be completed.

All keys operate as described in the Manual Loads sub-section of this appendix with the exception of the  button. This is now disabled, as it is the computers responsibility to sequence the load changes.

C.6 Configuration Options

If it is intended to only operate in Search Mode or Manual Loads mode without using preset loads then no set-up is required from this Configuration menu. All other modes operate with loads specified using options from this menu.

The Configuration options that are important for basic loadbank operation are covered in this sub-section. Other options from this menu should not normally require alteration except in special circumstances.

Test Supply Set-up

Press the  button on the Eclipse toolbar to display the current test supply parameters. If these are incorrect press the Edit button to allow these parameters to be altered. This will display the dialog box shown below in which the correct parameters can be entered.

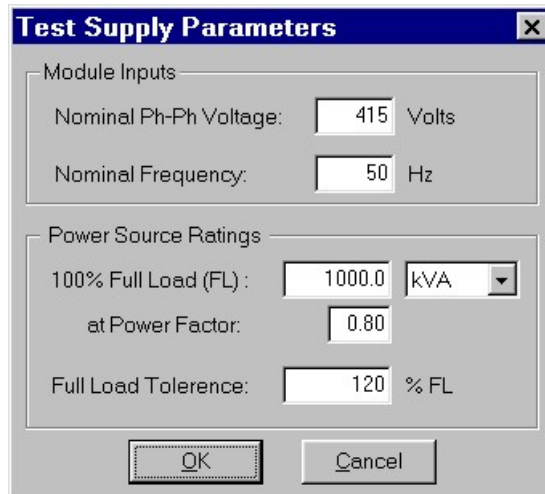

Enter the requested parameters for generator being tested. The full-load tolerance is the desired maximum load that the loadbank is to draw from the test supply, expressed as a percentage of the full-load entered above. The loadbank software uses these values to protect the test supply from excessive loads so it is important that the generator parameters are correctly specified.

Program Presets

To program a preset load select the Program Presets option from the Presets menu. A dialog box will be displayed showing a list of the twenty preset loads stored in the loadbank's memory. Select a preset from this list and press the Edit button. The dialog box reproduced below will be displayed.

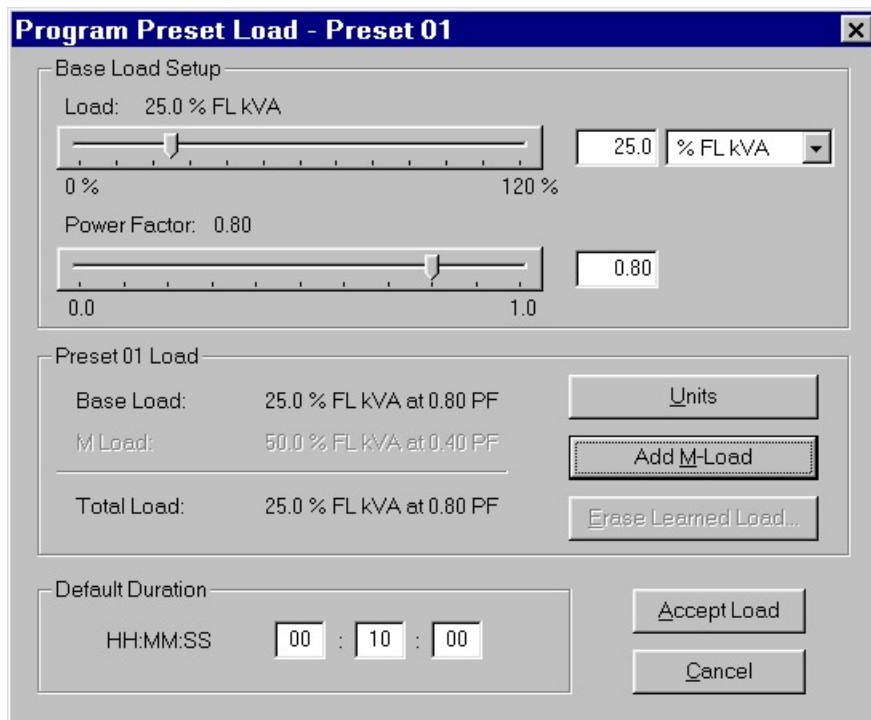

Use this dialog box to enter the percentage of full-load and the power factor for the selected presets base load. The dialog box also provides an option to add the M-Load to the base preset to provide a composite load when this preset is applied. Finally the duration must be specified if the preset is to be used in Automatic Load Profile mode.

Once the preset had been defined press the Accept Load button to return to the list of presets and select another for further editing if required.

Program M-Test Load

The M-Load is usually a low power factor load that simulates a motor starting current. It is usually applied for a short duration in addition to a specific base load condition.

Selecting the Set M-Test Load option from the Presets menu will display a dialog box in which the load and power factor of the M-Load can be defined.

Program Load Profile

To define a Load Profile for use in the Automatic Load Profile mode described previously, select the Create/Edit Load Profile option from the Presets menu. The dialog box shown below will be displayed.

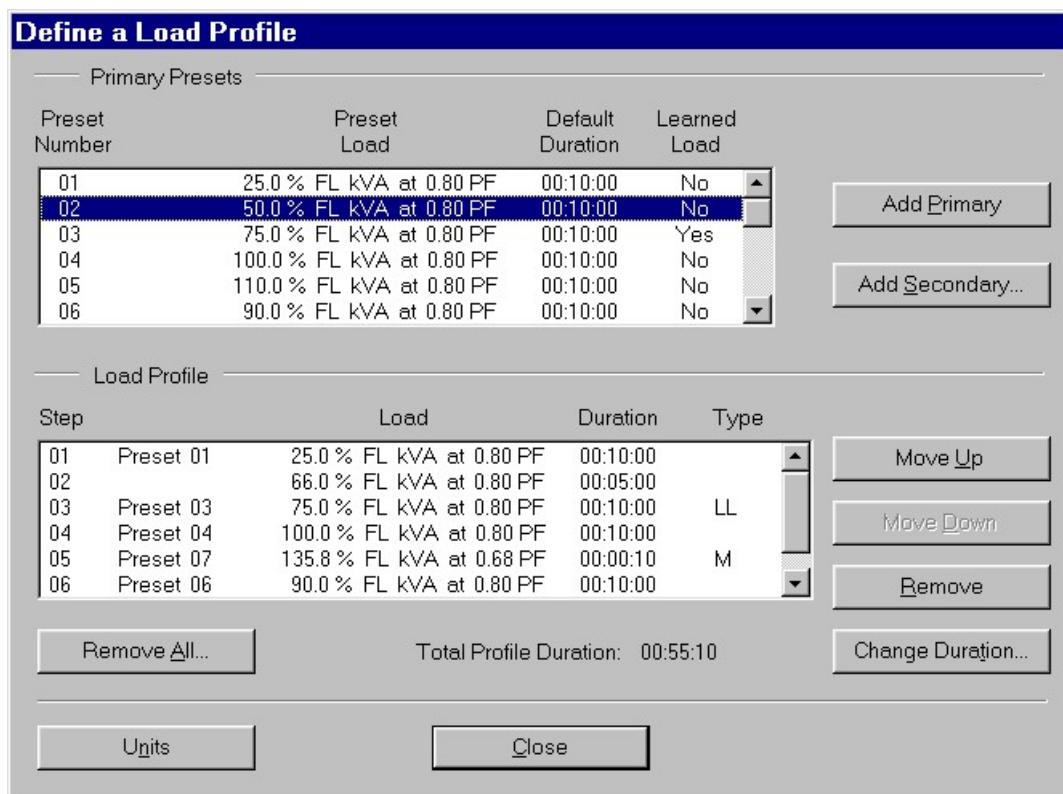

The top-half of the dialog box shows a list of the twenty preset loads that are available. The bottom list box will initially be empty.

To create a profile select the required preset from the list and press the Add Primary button. The selected preset will be inserted at the end of the list of load-steps in the Load Profile list box. Repeat this operation to add different presets to the profile until the required sequence of loads has been constructed.

The load profile can be edited to change the position of a load-step in the profile, remove a load-step from the profile or modify the duration of a specific load-step. To do this, select the required load-step in the Load Profile list box. Then use the Move Up and Move Down buttons to change its position in the profile list or press the Remove button to delete the load-step from the defined profile. To modify a load-steps duration select the step and press the Change Duration button.

Once the load-profile has been satisfactorily defined the dialog box can be closed and the profile is ready for use in Automatic Load Profile mode.

C.7 Shutdown Loadbanks

When all load testing has been completed and no load is applied, the  button can then be used to initiate the loadbank shutdown sequence.

Once this sequence commences the fans will run for up to 240 seconds to ensure the loadbank elements are at a sufficiently low temperature before the cooling fans are stopped and the loadbank power is removed.

During the shutdown sequence the screen below will be displayed showing the remaining countdown and allow the shutdown to be aborted if required.

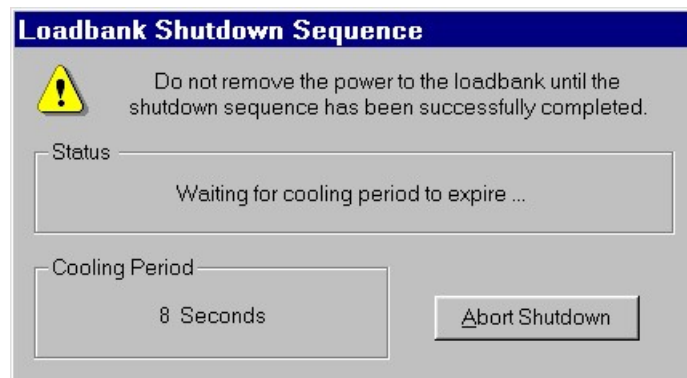

Once the cooling period has expired the fans will stop and the loadbank may be powered down.

The Eclipse control can then be closed by selecting the Exit option from the Commands menu or by pressing the Close button on the application title bar.

Appendix D Summary of On-Load Error Messages

The computer system in the loadbank performs error checking at two levels. Firstly, it checks that any parameter entered by the operator will not cause a load to be applied that could exceed the specification of the power source being tested as defined in the Generator Set-up menu.

Secondly, the loadbank computer will detect errors due to the operating parameters being exceeded or hardware failures.

When an error is detected or an invalid parameter entered, a message will be displayed to the operator giving the reason. Every effort has been made to ensure these messages are as easily understood and self-explanatory as possible, given the limitations of display size.

If a loadbank is continually shedding load due to Supply Voltage or Reactor Overload errors, it should not continue to be operated as the loadbank operating limits are being violated. Check the test supply ratings are correct for the specific loadbank being used. Note that if the control system is using an internal supply and this fails then it will not be possible to display an error message.

The error messages that can be produced whilst on-load are listed below, together with a brief description of their cause.

All Load De-allocated	When using multiple loadbanks, each will look at its local operating conditions to see if they are legal. If not, that loadbank will shutdown and its contribution to the total system capacity will be de-allocated. It is possible that after several failures all the loadbanks comprising a system are shutdown and the total capacity of the system is zero. If this occurs the test cannot continue so the error message is displayed and the system shuts down.
Communications Error	This message is displayed when a command sent to a remote loadbank is not acknowledged after several re-tries. In this case the communications system is deemed to have failed and the system is shutdown.
Communications Link Lost	If a request for data from a remote loadbank fails after re-tries then this message is displayed. This is then treated as a communications error and the loadbanks will shutdown.
Controller Disconnected	If the control terminal is disconnected or its cable damaged the loadbank(s) are deemed to no longer be under control and so they will automatically shutdown and this message will appear on any printout.

Emergency Stop Detected	This message is produced when the Emergency Stop button is pressed on a slave loadbank. This causes the “running” input to be negated, which is detected by the Eclipse software. All loadbanks will shutdown.
Reactor Overload	When using a reactive load, for any given operating frequency, there is maximum voltage above which the current flowing through the reactor will become excessive. When this voltage is reached this error message is displayed. The limiting voltage is calculated by reading the current operating frequency and using the reactor gradient value to calculate the maximum safe voltage, which must not be exceeded. This error is only generated when a reactive load is being used i.e. the power factor is less than unity. Error checking for this condition is performed even if “Nominal Values” have been selected. This error does not cause a loadbank to shut down once it has shed its load. The next time a load is applied the loadbank will go back on-load.
Loadbank Cooling Fault	A loadbank is not getting sufficient cooling airflow. This may be due to fan failure or blockage of the air intake vents. This error is not considered fatal to a multiple loadbank system.
Supply Voltage too High	The maximum supply voltage has been exceeded. This will cause the loadbank that has detected the problem to shed its load but it does not shutdown. The next time a load is applied the loadbank will go back on-load. This condition is tested for even if “Nominal Values” have been selected for use.
Supply Voltage too Low	The supply voltage has fallen below the minimum requirement. This will cause the local loadbank to go off-load when using multiple loads modules but it does not shutdown. The next time a load is applied the loadbank will go back on-load. This condition is not tested for when using “Nominal Values”.

Appendix E Glossary

This section defines terms used throughout this document.

Auto Load Profile Mode	The test mode where a profile of different loads is sequenced automatically by the computer.
Base Load	The nominal load value of a Preset before any M-Load is added to it.
Complex Load	A load that has both active (kW) and reactive (kVAr) components.
Composite Load	This is the sum of two Complex Loads. The load resulting from adding the M-Load to a Preset is a Composite Load.
Dynamic Adjustment	see Load Adjustment.
Dynamic Sensing	This is the measuring of voltage and frequency values at the loadbank. These values can be used for the calculation of a new load.
FL	see Full Load
Full Load	This is the 100% nominal rating of the equipment under test.
Full-Load Tolerance	The maximum percentage of the full load power that the loadbank is permitted to draw.
Generator Set-up Menu	This is an option under the Configuration Menu where all the parameters defining the equipment under test are grouped. All these parameters must be correctly set for the generator being used if the loadbank software is to protect the generator from excessive loads.
HHT100 Controller	This is <i>Crestchic's</i> own custom-designed hand-held electronic loadbank control module.
ILS	This is the Initial Load Signal. It is used internally by the computer as a representation of the amount of resistive and reactive load.
kVA	This is the total apparent power. This is the complex sum of resistive and reactive components of power.

kVAr	This is the reactive component of the load.
kW	This is the resistive component of the total load, sometimes termed true-power or active-power.
Learned Load	An adjusted or trimmed preset Load that has been stored by the operator. When this preset load is next used the adjusted load will be applied rather than a calculated one.
Load Adjustment	This is used to alter the applied load to compensate for inaccuracies between a calculated load and the requested load.
Load Profile	See Profile
Manual Load	A load entered and applied by the operator. This is expressed in terms of the desired load kVA, kW or Amps and power factor.
Manual Load Mode	The test mode where loads, entered by the operator are applied.
Master Loadbank	When using multiple loadbanks the master loadbank is the module that the controller is connected to. There should only be one controller connected to each system of loadbanks i.e. only one master.
M-Load	This is a Complex load representative of an electric motor being started direct-on-line.
M-Test	This is used to add the M-Load to a preset's base-load simulating a motor start on an already laden generator.
Nominal Values	These are values for the nominal voltage and frequency rating of the equipment under test. They are used for load calculations and are entered by the operator from the keyboard.
PC	Personal Computer. This is the notebook computer used as the operator interface to control the loadbank.
PF	Power Factor
Preset Load	A Complex load that has been previously programmed. Preset loads are retained in non-volatile memory.
Profile	A number of preset loads applied sequentially to test the load-change performance of the equipment under test.

Search Mode	The test mode where the operator directly manipulates the applied load. It is used to search for critical nodes of operation of the equipment under test.
Slave	When using multiple loadbanks, a slave module is one that is not controlled directly by the operator but takes its instructions from a remote master loadbank.
Transient	The excursion of voltage and frequency that occurs when the load on a generator is changed.
Transient Response File	The text file downloaded to a PC hard disk containing header information about the load-change followed by time voltage and frequency values recorded during the load-change in comma-separated value (CSV) format.
TransView	The <i>Crestchic</i> program used to view and print a transient response file in graphical format.
Trimmed Load	A preset load that has been manipulated by the operator. A trimmed load may be learnt.
Trim Resolution	The amount by which an applied load is altered. This can be Coarse (5% of FL, 0.05 change in PF), Medium (1% of FL, 0.01 change in PF) or Fine (0.2% of FL, 0.002 change in PF).



Crestchic Loadbanks
WORLDWIDE LOADBANK SPECIALISTS

9. ECLIPSE AC LOADBANK OPERATING INSTRUCTIONS FOR HHT CONTROLLER

Eclipse

AC Loadbank Operating

Instructions for HHT100

Controller

Crestchic Limited
2nd Avenue
Centrum 100
Burton upon Trent
Staffordshire
United Kingdom
DE14 2WF

Tel. +44 (0) 1283 531645
Fax. +44 (0) 1283 510103

Reproduction of this document, in part or whole, by any means, electrical, mechanical, optical, chemical, manual or otherwise is prohibited without written permission from Crestchic Limited.

This document reflects edition 20 or later of the EclipseRT software. The information contained herein is believed to be accurate as of the date of publication, however, Crestchic Limited will not be liable for any damages, including indirect or consequential, arising from use of the hardware or software described within or reliance upon the accuracy of this documentation. The information contained herein is subject to change without notice.

Revision: B
Date: 15th August 2002
Author: R. Warwick

Contents

<u>Section</u>	<u>Page</u>
1.0 Introduction	4
2.0 Operator Interface	5
2.1 General Principles of Use	5
2.2 Display Contrast	6
3.0 Start Up Sequence	7
4.0 Keypad Loads	10
5.0 Configuration Menu	15
5.1 Generator Parameters	15
5.2 Program Presets	17
5.3 Program M-Test Load	19
5.4 Printer Parameters	20
5.5 Other Configuration Menu Options	21
6.0 Manual Preset Loads	22
6.1 On-Load Menu	23
6.2 Load Adjustment	24
7.0 Automatic Preset Loads	27
8.0 Search Mode	29
9.0 Loadbank Shutdown	31
10.0 Transient Response	32
10.1 Overview	32
10.2 Transient Menu	32
Appendix A Summary of On-Load Error Messages	34
Appendix B Summary of Key Functions when On-load	36

Appendix C Quick Start Guide	38
C.1 Setting Up	38
C.2 Start Up	38
C.3 Keypad Loads	40
C.4 Manual Preset Loads	41
C.5 Automatic Presets	42
C.6 Search Mode	43
C.7 Configuration Menu	43
C.8 Shutdown Loadbanks	45
 Appendix D Glossary	 46

1.0 Introduction

This document describes the operation of *Crestchic* Loadbanks using the computerised Eclipse AC Load Control System with an HHT100 controller. **These are general instructions and some of the facilities and options described will depend upon the size, specification and operating range of loadbank being used.**

The computer control system is split into two parts. Firstly there is a powerful microprocessor board situated in the loadbank enclosure. This processor is responsible for the actual calculation and control of the applied load, and the monitoring of the loadbank operating conditions.

The second part of the control system is an electronic controller unit that can be sited at a distance from the loadbank - for example, in the control room of the equipment under test. This controller can be either a custom designed *Crestchic* hand-held control terminal, the HHT100, or a laptop personal computer (PC) running *Microsoft* Windows. The controller is used to provide the operator interface, allowing the required load steps to be set-up and applied and then displaying instrumentation data whilst on-load.

For several reasons it is recommended that a PC be used as the loadbank controller whenever possible. Firstly, because the Eclipse software runs under the Windows operating system it is able to utilise the standard control features familiar to almost everyone who has used a PC. This greatly reduces the learning curve encountered when using the software for the first time as well as making the loadbank operation easy and intuitive. Secondly the Eclipse software fully exploits the display and storage capabilities of a PC providing enhanced facilities and more loadbank functionality than available when using the HHT100 controller.

The Eclipse software can also be supplied on CD-ROM to allow customers to use their own Windows PC to control the loadbank. This software will run under Windows 95/98/ME and Windows NT/2000. Note that a suitable inter-connection lead must also be purchased to link the PC and loadbank together.

It has been attempted to define and explain new terms as they are introduced in the text. However, this has not always been possible. Therefore a glossary of terms is appended at the end of this document for reference purposes.

2.0 Operator Interface

2.1 General Principles of Use

The HHT100 controller has been custom-designed so that only the necessary keys appear on the keypad. The backlit LCD display is used to request instructions and display data to the operator. Because of the limited size of this display it is not always possible to show all the items of a menu simultaneously on the screen. In this case the arrow keys can be used to scroll down through the menu until the desired option is visible on the screen.

The numeric keypad, ENTER and CANCEL keys, and arrow keys are most frequently used and special functions are performed using the dedicated keys at the top of the keypad.

The ENTER key is used to confirm a selection or show that a numeric entry is complete. The CANCEL key is generally used to return to the previous screen without changing any data. The CANCEL key can also be used to return to the previous menu if an incorrect item is selected. When numeric data is being entered, and a typing error is made, the incorrect number can be deleted by using the DEL key.

If the value for a parameter being entered is to remain unchanged pressing the ENTER key will accept the current value rather than having to re-type the same number. For example, if the current value of the power factor is 0.8 and this is to remain unchanged, just pushing the ENTER key will retain this power factor and move on to the next stage of load set-up.

After entering numeric data, the resultant values are usually displayed and the operator is asked to confirm that these are correct by pressing the ENTER key. If an error is spotted at this stage the CANCEL key can be pressed and the values will be requested again, or the previous screen will be displayed.

When there is a choice of options available then these are usually presented in the form of a menu with the first option highlighted using the right chevron (>) symbol. An option can be selected by entering its number from the menu. For example, to choose the Configuration Menu from the Main Menu, simply type '5' on the keyboard. Alternatively an option in the menu can be highlighted by using the up and down arrow keys to select it and pressing the ENTER key to accept it. Operators may use whichever of these methods they feel more comfortable with.

The Eclipse software will allow load values to be entered and displayed in several different units. When load information is to be entered the UNITS key can be used to specify the units in which the load is to be input. Repeatedly pressing this button will step through the units Amps, kW and kVA. When the desired units are displayed the size of load can be entered.

When a load or preset is being displayed the UNITS key can also be used to show the equivalent load in each of the different units. This is accomplished by successively pressing the UNITS key. This feature is available whenever a load is displayed on the screen.

On earlier models of the HHT100 controller the UNITS and PHASE keys may not be marked as such. In these circumstances the F4 and F5 keys will perform the same functions. The F4 key corresponds to the PHASE key and the F5 key to the UNITS key.

2.2 Display Contrast

When operating in extreme temperature conditions the display on the controller may appear faded and become difficult to read. This is due to the ambient temperature affecting the performance of the liquid crystal panel, and is an inherent characteristic of all LCD displays.

In these circumstances it is possible to change the contrast of the LCD display to make the screen display more legible. To do this first press and release the SHIFT button on the keypad and then press either the UP ARROW or DOWN ARROW key to lighten or darken the screen contrast. Repeat this process until the optimum display clarity is achieved.

3.0 Start Up Sequence

When starting the system the loadbank(s) should be switched on first. Before doing so ensure the emergency stop buttons are deactivated on all the units and if a signal distribution pod is being used check its Load Dump switch is in the normal position. Power-up each loadbank by moving the Control Supply selector switch from the OFF/RESET position. Obviously for a loadbank control system to function when it is being powered internally from the test supply that power source must be providing voltage to the bus bars at this point. Any slave loadbank(s) should be powered-up first followed by the master loadbank.

The HHT100 controller will come on when the auxiliary supply to the loadbank is switched on. There is no separate on/off switch on the HHT100 unit. If a printer is being used this should also be turned on at this point.

Once the loadbanks(s) are switched on the controller will display:

```
ECLIPSE LOAD SYSTEM

Press ENTER to Start
the System
```

Pressing ENTER will instruct the master loadbank to determine the total load capacity of all the slave loadbanks connected to the master loadbank.

Once the size of the configured load has been determined the display shows the results on the screen as reproduced below. The nominal capacity figures should be checked to ensure the loadbank is capable of providing the load required to fully test the power source.

```
ECLIPSE LOAD SYSTEM

Nominal Capacities:
415V 50Hz: 934 kW
           646 kVAr
440V 60Hz: 1050 kW
           605 kVAr

ENTER to Continue
```

By again pressing the ENTER key the next stage in the start-up sequence is reached.

This screen gives details of the operating mode of the loadbank, single-phase or three-phase, and the voltage range that the loadbank is designed to be used within. If an attempt is made to use the loadbank to test a supply that is outside of these limits then an error message will be displayed and any load applied at the time will be shed.

```
ECLIPSE LOAD SYSTEM  
  
Supply Type = 3-Ph  
  
Max Volts   = 490 V  
Min Volts   = 346 V  
  
ENTER to Continue
```

By again pressing the ENTER key the next stage in the start-up sequence is reached and the screen displayed is reproduced below.

```
ECLIPSE LOAD SYSTEM  
  
Press ENTER to Start  
the Cooling Fans  
or CANCEL to proceed  
with no Fans running
```

Pressing ENTER will begin the fan start sequence. This may take up to a minute to complete depending upon the number of cooling fans fitted within the loadbank. If the CANCEL key is pressed then the computer defers the starting of the fans until a load is to be applied. This enables parameters to be set-up without the distraction of fan noise.

The next screen gives details of the generator to be tested. The values displayed are the nominal values for the generator. The Generator Specification screen is reproduced below.

```
GENERATOR RATINGS  
V & Hz : 415V 50Hz  
100% FL: 300 kVA  
@ : 0.80 PF  
FL Tol : 110 %  
Calcs : Instruments  
ENTER to Continue  
or CANCEL to Edit
```

By pressing the UNITS key repeatedly at this point the load can be displayed in terms of kVA, Amps or kW.

The generator parameters entered by the operator are stored in non-volatile memory in the loadbank computer and are displayed every time the loadbank is started. The generator specification may be edited at this point should a different generator be being tested from when the loadbank was last used.

It is important that the generator is specified correctly and the maximum tolerance on the nominal full load output is given. It is these parameters that the loadbank computer uses to ensure that excessive loads are not applied to the generator. More information on editing the Generator Specification is given in the Configuration Menu section of this manual.

Once the generator has been correctly specified press the ENTER key to proceed with the start-up sequence.

At this point a screen may be displayed enquiring if the operator wishes to retain previously learned loads. Learned loads are stored whilst working on a particular piece of equipment to allow a specific load to be recalled. If the loadbank is being used with the same equipment as when the loads were learned, and there have been no other changes in the test environment, then the loads may be retained. Otherwise the learned loads are invalid and should be erased.

The start-up sequence is now complete and the main menu, shown below, is displayed giving the different modes that are available.

```
ECLIPSE LOAD SYSTEM  
  
Select function:  
  
>1 Keypad Loads  
2 Manual Pre-Sets  
3 Auto Pre-Sets  
4 Search Mode
```

4.0 Keypad Loads

This mode offers the simplest form of loadbank control where a load, as the name implies, is set-up from the keypad and applied to the equipment under test. The load is defined in terms of the required load current (Amps), the true power (kW) or the apparent power (kVA), and the power factor. The computer will calculate the necessary resistive and reactive components from these entries.

When Keypad Loads mode is selected the computer first asks for the value of load to be applied. Pressing the UNITS key will alter the units in which the load is expressed.

Type the desired value and press the ENTER button.

New Load

Old: 0.0000 kVA

New: ----- kVA

When using a resistive/reactive loadbank the display will then request the power factor to be entered at which this load is to be applied. When entering the load in Amps or kVA a power factor from 0.0 to unity may be used. When entering the load in kilowatts the power factor entry is limited to a 0.1 minimum value.

If a resistive-only loadbank is being used then the power factor will automatically be set to unity and the operator will not be asked to enter a value.

The power factor entry screen is reproduced below.

New Power Factor

Old: 0.0000

New: -----

Once the power factor is entered the computer will ask the user to confirm the load entered. To see the equivalent load expressed in different units the UNITS key can be pressed repeatedly. If the load is correct press the ENTER key, otherwise entry of the new load can be aborted by pressing the ESC key.

```

New Load :

20 kVA @ 0.80 PF

ENTER to Confirm

```

At this stage the computer will check that the entered load does not exceed the generator limits, as defined in Generator Specification Menu. Should this be the case the controller will display an error message and the cause of the error. The controller will then prompt for the load to be re-entered.

Once the load has been confirmed and accepted the computer will display a screen asking if the results of this load test should be recorded using the RS-232 printer. If a record of this particular load test is required the operator should select the printer. The test results will be written to this device. This screen is reproduced below:

```

Test Results
Select the device
to output the above
data to:

>1 No Output
2 RS-232 Printer

```

Once the test results destination has been selected the on-load screen is displayed. Note that the load is not yet applied at this stage.

The HHT100 display has two display modes that can be switched between to obtain all the information about the current operating status of the loadbank and its instrumentation values.

Both the display modes are shown below. The first display mode is shown on the left and this gives the total powers and the average current for the applied load. The second display mode is selected by pressing the PHASE button. This is represented on the right and shows the individual powers and currents in each phase. Pressing the PHASE button again will return to the first display mode showing the total values.

```
Ld:    0kVA @ 1.00PF
      00:00:00
      415.0 Volts
      0 kVA    0 Amps
      0 kW     0 kVAr
      50.2 Hz  1.00 PF
      0.0 % kVA
      ENTER for New Load
```

```
Ld:    0kVA @ 1.00PF
      00:00:00
      415.2 V R    0 kVA
      415.1 V S    0 kVA
      415.2 V T    0 kVA
      50.2 Hz    1.00 PF
      0.0 % kVA
      ENTER for New Load
```

When the on-load screen is displayed the requested target load in the currently selected units is shown at the top of the screen. Initially this will be zero as no load is applied. The elapsed time is shown on the next line below the target load.

The next three lines depend upon the display mode. In the first mode the voltage, total powers and average current measurements are shown. The alternate display mode gives details of the individual phase readings. Pressing the UNITS key will cycle through every set of measurements (kVA, kW, Amps) for each phase. In kVA mode, as shown above, the phase-phase voltages are shown otherwise the phase-neutral voltage is displayed.

Below these values in both display modes are the secondary instrumentation readings and status information. These include the frequency, power factor, the percentage of full load applied in the currently selected units. The bottom line on the screen is the user prompt line giving useful operating information.

Having set up the load pressing the ENTER button will apply the requested load and the display will start continually updating with measured values.

The screen below shows the on-load display in kVA mode. Both display modes are shown to illustrate the different information that can be shown by pressing the PHASE button to toggle between the modes.

```
Ld:    150kVA @ 0.80PF
      00:00:21
      415.2 Volts
      150 kVA   209 Amps
      122 kW    86 kVAr
      50.1 Hz  0.81 PF
      50.1 % kVA
      ENTER for Adjust
```

```
Ld:    150kVA @ 0.80PF
      00:00:21
      415.2 V R   50 kVA
      415.1 V S   50 kVA
      415.2 V T   50 kVA
      50.1 Hz    0.81 PF
      50.1 % kVA
      ENTER for Adjust
```

Pressing the UNITS key will change the display mode to Amps and show the phase-neutral voltages.

```
Ld: 209A @ 0.80PF
    00:01:48
    415.2 Volts
    150 kVA    208 Amps
    123 kW     87 kVAr
    50.1 Hz    0.80 PF
    49.9 % Amps
    ENTER for Adjust
```

```
Ld: 209A @ 0.80PF
    00:01:48
    239.4 V R  208 Amps
    239.9 V S  209 Amps
    240.1 V T  208 Amps
    50.1 Hz    0.80 PF
    49.9 % Amps
    ENTER for Adjust
```

Pressing the UNITS key again will change the display to kW mode showing the kW in each phase and the phase-phase voltages. Pressing the UNITS key for a third time will return the display to kVA mode.

The kW mode screen is shown below.

```
Ld: 120kW @ 0.80PF
    00:02:14
    415.1 Volts
    150 kVA    209 Amps
    121 kW     86 kVAr
    50.1 Hz    0.80 PF
    50.3 % kW
    ENTER for Adjust
```

```
Ld: 120kW @ 0.80PF
    00:02:14
    415.2 V R  41 kW
    414.9 V S  40 kW
    415.3 V T  40 kW
    50.1 Hz    0.80 PF
    50.3 % kW
    ENTER for Adjust
```

The prompt line will usually give a reminder that Load Adjustment is available. Load Adjustment is used to obtain the requested load by modifying the size of the load components that were initially calculated prior to the load-change. This compensates for any changes that occur after the load has been applied, for example voltage-drop due to the loading on the generator, or thermal drift of the loadbank elements as they heat up.

Pressing the ENTER key will start the Load Adjustment causing the computer to adjust the applied load whilst comparing the measured load to that requested by the operator. This continues until the requested current or power is being taken from power source under test. If, during load adjustment, the ENTER key is pressed again the adjustment process will cease and the load is left at the value it has reached.

Load Adjustment will modify the resistive and reactive components to try and achieve the target load in the currently selected units. For example, in Amps mode it will strive to produce the requested current, which may result in the kW or kVA being incorrect due to voltage variations. It is therefore important to use the UNITS key to select the load that is to be achieved in the correct units before starting the adjustment.

The loadbank can perform step changes by altering the load to a higher or lower value from the currently applied load. Pressing the LOAD key will give access to the load entry screens.

The load and power factor should be entered in the same manner described previously. After the new load has been confirmed, and the computer accepts it as being within the generator operating limits, the on-load screen is re-displayed. Again the new load has not yet been applied at this point but is set-up ready for when the ENTER key is pressed. The prompt line will show that the new load is ready for application.

The operator may conclude the testing at any time by pressing the CANCEL key. A double-strike feature protects this key so that the inadvertent operation will not cause the load to be shed. The screen displayed when the CANCEL key is first pressed is shown below.

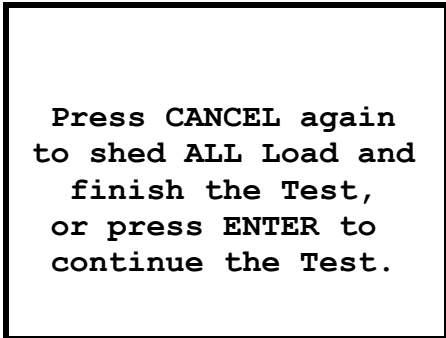

**Press CANCEL again
to shed ALL Load and
finish the Test,
or press ENTER to
continue the Test.**

Pressing the CANCEL key again will shed all load and return to the Main Menu.

As an alternative to shedding the entire load at one time, the DUMP button may be used. This enables the load to be shed in 25% stages. It can be used as a 'Panic Button' if too much load is applied to the power source. The DUMP key can be used repeatedly to reduce the load down to a safe level. Again, a double-strike feature protects this key to prevent accidental operation. The screen produced when the key is first pressed is shown below.

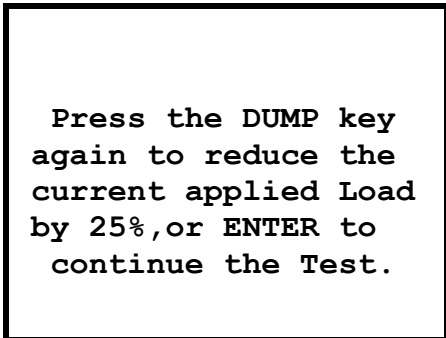

**Press the DUMP key
again to reduce the
current applied Load
by 25%, or ENTER to
continue the Test.**

If the operator selected that a Test Report be produced during the load-run, the computer will periodically output the instrumentation readings to the printer. The time interval between each set of measurements being printed is known as the Printout Interval and is set in the Configuration Menu.

5.0 Configuration Menu

Before the more advanced test modes of the loadbank are discussed the Configuration Menu should first be examined, as the parameters in this menu directly affect the use of Preset Loads. Selecting option five from the Main Menu accesses the Configuration Menu. It may be password protected to prevent the alteration of data by unauthorised personnel. If this is the case enter the password when prompted by the display. The Configuration Menu is shown below.

```
          CONFIG MENU

Select parameter :

>1 Generator Setup
 2 Program Pre-Sets
 3 Program M-Test
 4 Transient Values
```

Details of working with Transients are covered in a later section of this manual. Other options from the Configuration Menu are discussed below.

5.1 Generator Parameters

All the parameters needed to define the characteristics of the generator under test are grouped together in a single sub-menu.

The Generator Set-up Menu is the first menu that should be accessed when setting up the loadbank to test a piece of equipment, as this is where the nominal output of the power source is defined. The values entered here will define the limits of operation and the actual size of load applied when working in Preset Modes and Search Mode.

The generator ratings are displayed when the first option of the Configuration Menu is selected and the operator is invited to edit the values if necessary. The equivalent full load can be displayed expressed in different units by pressing the UNITS key. The generator-rating screen is shown below:

```
          GENERATOR RATINGS
V & Hz : 415V 50Hz
100% FL: 300 kVA
   @   : 0.80 PF
FL Tol : 110 %
Calcs  : Instruments

          ENTER to Edit
```

The loadbank software uses the values entered at the Generator Ratings screen to protect the equipment under tested from being subjected to excessive loads. Therefore **it is vital to ensure that the generator is correctly specified each time the loadbank is used.**

The generator ratings may be entered as part of the loadbank start-up sequence or at any time from the Configuration Menu. If the Generator Specification is to be altered press the ENTER key to show the Generator Set-up Menu as reproduced below.

```
Generator Setup
Select parameter :
>1 Nominal V & Hz
 2 100% Load Power
 3 Max FL Tolerance
 4 V & Hz Source
```

Nominal Voltage and Frequency

Use this option to input the values of the nominal voltage and frequency that the generator outputs. The values entered are checked to ensure they are within the loadbank operating limits before being accepted by the system. Do **not** exceed 440V when using reactive loads with a 50 Hz supply frequency.

100% Load Power

This is the nominal full-load power or current that the generator under test is capable of supplying. It can be entered as an Amp, kW or kVA value at a power factor. The 100% load power is fundamental to the operation of the loadbank as this value is used to provide overload protection in all operating modes. Preset Loads are also expressed as a percentage of this value and when trimming a load, or in Search Mode, the load is increased or decreased by a percentage of this figure.

If the value is changed then any learned loads associated with a preset will be erased, as they will no longer be valid.

Maximum Full Load Tolerance

This parameter should be set to highest rating that the generator will have to supply continuously, for example 110% if overload testing is to be carried out. It can also limit the size of load applied. For example, if it were set to 50% then the loadbank would only permit loads up to half of the generators load-rating to be applied. Setting this variable will prevent the loadbank from applying loads greater than the specified tolerance in all operating modes.

Source of V and Hz for Calculations

During the calculation of the load necessary to draw the power requested by the operator the computer utilises values for voltage and frequency. By selecting this option the operator can choose the source of these figures; either the nominal values for the generator or the actual transducer values measured by the loadbank instrumentation during the load test.

The selection screen is shown below. The operator must select which source of voltage and frequency figures will be most suitable. If use of the instrumentation values is disabled then the nominal values will automatically be used.

**Use of Instruments
is Enabled**

**ENTER to Disable
or CANCEL to Exit**

There are advantages and disadvantages to both sources of these values. If nominal values are used these are obviously fixed throughout the range of the test, whereas the voltage supplied by the equipment being tested may fall as the load is increased. In this case using the instrumentation values would result in the load being calculated more accurately.

Alternatively, if there is significant voltage drop between the generator output terminals and the loadbank bus bars, where values are measured by the instrumentation, then using the nominal values of the generator output will give a more accurate load calculation. It is up to the operator to select which mode to use based on the individual circumstances of each installation.

When a loadbank is first switched on it always defaults to using measured values as this method generally gives the more accurate results. If nominal values are to be used the operator must explicitly change to this mode of operation. It should be noted that if the loadbank were subsequently re-started the computer would return to the default mode of using instrumentation values.

5.2 Program Presets

This menu option is used to program the twenty individual preset loads. First a screen allowing access to all twenty presets is displayed. The list of presets can be moved through by using the UP and DOWN arrow keys.

The display shows each preset load as a percentage of the generator 100% full load power in the currently selected units, the power factor and whether the total includes an M-Test load. The duration for each preset load, which is used when in automatic mode, is also shown. This screen is shown below.

```
FL:  300kVA @ 0.80PF
M:   50% FL @ 0.40PF

      Select a Preset
      to Edit:

>01  25%FL @ 0.80 PF
      for 00:10:00
```

There are two types of preset, Base and Base + M-Load. Base load presets may be programmed as any percentage of the generators full-load rating. However, if an attempt is made to program a preset above the current full-load tolerance a warning message will be displayed. The preset will remain programmed at this level but its application will not be permitted in either Manual or Automatic Presets Mode.

The second type of preset consists of a Base load with addition of an M-Test load. The M-Test, or Marine Test, is mainly used, as the name implies, to provide marine engines with a short duration overload test. The M-Test load can be added to any of the twenty preset loads. In this case the computer will add the preset base load and the M-Test load together to produce a composite load and then apply this to the generator under test. The composite load is calculated automatically with no need for the operator to become involved in complex mathematics.

Presets that include an additional M-Test load are usually used to test extreme overload situations. Therefore these types of presets are permitted to exceed the generator full-load tolerance. This is the **only** time the loadbank will allow a load above the full-load tolerance to be applied.

As a safety precaution the use of Base + M-Load presets is limited. They can only be applied as part of an automatic load profile under computer control, and then only for a maximum duration of ten seconds.

A preset is selected for editing either by entering its number or highlighting it using the arrow keys and pressing ENTER. Once a selection is made the details of the preset are shown and a menu provided to allow variables to be changed.

The first line of the display shows the 100% generator full load in the currently selected units. To view the equivalent full load in different units press the UNITS key. The next line shows the selected preset number and its type.

This Preset Programming screen is reproduced below.

```
FL: 300kVA @ 0.80PF
01: Base Load Only
      %FL @ PF
Base : 25 0.80
Total: 25 0.80
For : 00:10:00
      Value to alter
>1 Base Load
```

The values for the size and duration of the selected preset can be set-up by choosing each option in the menu until the load is fully specified. It is important to remember that the load size is specified as a percentage of the full load **in the currently specified units**. Ensure the correct units are selected using the UNITS key before the load is defined.

The duration is only applicable if the preset is to be used in Automatic Presets mode where loads are sequenced by the computer.

Each preset load can be programmed in this way. In Automatic Preset mode the preset loads are used in numerical order and so this may determine the position of an entry in the preset table to allow the load to ramp up and down again sequentially. It is not recommended that the duration of a base preset be less than ten seconds.

5.3 Program M-Test Load

When this menu option is selected the operator is asked to modify the M-Test load. This is expressed as a percentage of the full-load power of the equipment under test (in the currently selected units) and a power factor. The 100% full-load power is entered in the Generator Set-up menu, discussed previously in this section. To express the load in kVA, kW or Amps the UNITS key is used to step through the available units.

```
100% FL :
300 kVA @ 0.80 PF

M-Test Load
50% FL @ 0.40 PF

ENTER to Edit M-Test
or CANCEL to Exit
```

If the M-Test load is changed, and it is currently included in any preset loads then these presets will revert to their base loads. Therefore the M-Test load should be defined before the programming of any presets that will use it.

5.4 Printer Parameters

This menu allows the parameters used for the Test Report printout to be specified.

The parameters set-up in the Printer Menu are retained in the loadbanks non-volatile memory and so do not have to be re-entered every time the loadbank is used.

```
PRINTOUT MENU

Select parameter :

>1 PrintOut Period
 2 PrintOut Units
 3 Report Type
```

Printout Period

When the loadbank is on-load the computer will output measured values from the instrumentation at regular intervals. Selecting this menu option allows the number of seconds between these outputs to be defined.

Printout Units

This option enables the setting of the units that target loads are expressed in on the Test Report. Target loads can be shown in Amps, kW or kVA. The units used for target loads on the Test Report are independent of the currently selected units on the controller display.

Report Type

Two types of report are available. The standard report type will record the instrumentation readings for the total load on one line each time the printout interval expires. A full report will record the readings for the total load on the first line and then the instrumentation readings for each phase on the three following lines each time the printout interval expires.

The type of report to be produced is left to the operators' discretion and will depend upon the amount of information required.

5.5 Other Configuration Menu Options

Set Date and Time

This option allows the current date and time used by the system on printouts to be reset. The time is stored by the computer in the loadbank and is retained using a re-chargeable battery when the loadbank is not powered.

Print Preset Loads

Selecting this option from the menu will cause a listing of all the Preset Loads to be sent to the printer.

Change Password

This option allows the password used to access the Configuration Menu to be altered. The password is a numeric value. If zero is selected as a password then access to the Configuration Menu is not protected; otherwise the password will be requested from the operator every time the Configuration Menu is selected from the Main Menu.

Care should be taken when changing the number to ensure it is memorised to prevent the operator from being locked-out of the Configuration Menu.

6.0 Manual Preset Loads

This test mode allows the Preset Loads defined in the Configuration Menu to be called up and applied to the generator under test in any order and whenever the operator desires.

When the Manual Presets mode is selected the operator is presented with a screen showing the details of the available presets and requested to select a Preset Load to apply. The first four presets will be visible on the display. To view the other presets use the UP and DOWN arrow keys to move through the list.

```
FL: 300kVA @ 0.80PF
M: 50% FL @ 0.40 PF
Select a Preset
  %FL @ PF
>01 25 0.80
02 50 0.80
03 75 0.80
04 100 0.80
```

Loads can be displayed as percentages of the different units by pressing the UNITS key. A preset is selected by entering its number and pressing the ENTER key or highlighting the preset and pressing ENTER.

The computer then displays the load in the current units and asks the operator for confirmation of the selection.

```
New Load :

75 kVA @ 0.80 PF

ENTER to Confirm
```

The operator will be asked if they wish the Test Report to be produced. The on-load screen is then displayed.

As with using Keypad Loads, the load is not yet applied. To do so the operator must press ENTER. The requested load will then be applied and the on-load screen will show instrumentation readings.

The on-load screen is reproduced below.

```
01:    75kVA @ 0.80PF
        00:00:18
        415.2 Volts
    75 kVA    104 Amps
    62 kW     44 kVAr
    50.1 Hz   0.81 PF
        25.1 % kVA
    ENTER for Adjust
```

The computer shows the preset number and the nominal amount of the target load on the first line of the display followed by similar information to that displayed in Keypad Loads.

The CANCEL key, DUMP key, UNITS key and PHASE key operate exactly as discussed in the Keypad Loads section of this document.

The LOAD key also has a similar function as when used in Keypad Loads mode. Again it is used to set-up the next load to be applied, but instead of requesting values entered via the keyboard, the screen displaying the available presets is shown from which the operator can select the next load. Once this is selected and the entry confirmed the on-load screen is returned to and the new load applied when the ENTER key is pressed.

If an attempt to apply a preset that exceeds the generators full-load tolerance, or an M-Test preset is selected, the computer will display an error message and not allow the preset to be used. A different preset must be selected in these circumstances.

6.1 On-Load Menu

The MENU key is used to call up the On-load Menu. This menu mainly duplicates some of the options on the Configuration Menu to allow values to be altered without having to terminate a test to access the Configuration Menu.

The On-load Menu is reproduced below.

```
ON-LOAD MENU

Select parameter :

>1 Transient Values
 2 Generator Ratings
 3 V & Hz Source
 4 Printout Values
```

The first option on the menu is used when working with Transient Response data. This option is described in detail in a later section of this manual.

The second item on the On-load Menu will display the current generator rating parameters. This display is intended as an aid should the generator limits need to be checked whilst on-load. The parameters cannot be edited whilst the generator is on-load.

The third and fourth menu entries allow access to the same options that have already been discussed in the Configuration Menu section of this document.

The final option will display the value of load components of the currently applied load. This feature is intended for use by *Crestchic* personnel to ensure correct functioning of the loadbank.

6.2 Load Adjustment

When a preset load has been calculated and applied, load adjustment may be performed to bring the power (or current) and the power factor to the requested values. The load produced by the loadbank will have been adjusted from that originally calculated to take account of any changes in the system such as a change in voltage from the generator after the load-change or change of resistance as the loadbank elements heat-up.

If the LEARN button on the HHT100 is then pressed the adjusted load value is 'learned' by the computer and stored with the preset details. The next time the preset is called the loadbank will use the adjusted load value and this should result in the applied load being very close to the desired value provided the generator voltage and frequency output are not significantly different from when the load was learned.

The controller display will show '(L)' to indicate the currently applied load is a learned-load. Also, when selecting a preset to apply, the letter L at the end of the preset details signifies that a preset is a Learned Load.

The display produced by pressing the LEARN key is shown below.

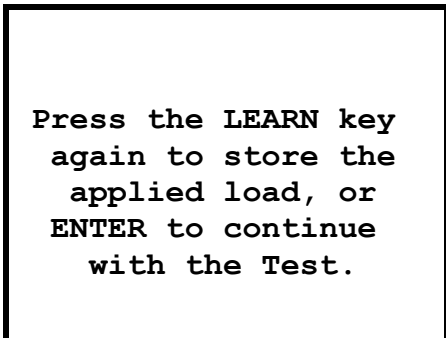

**Press the LEARN key
again to store the
applied load, or
ENTER to continue
with the Test.**

Another situation where the calculated load may lead to an incorrect total load is when there is an additional standing-load on the generator being tested, other than that supplied by the loadbank, such as the power supply for the generator services. In this case the option is available to manually trim the loadbank load so that the total load, as seen at the generator, is equal to the nominal value of the preset. This facility is also useful to trim the load to match external instrumentation.

Pressing the TRIM key enables the load trim facility. The display then changes to show the trim resolution - coarse, medium or fine. These resolutions can be cycled through by repeatedly pressing the TRIM key.

The applied load is trimmed by use of the four arrow keys. These operate on the load in different ways depending upon the current units selected. In kVA and Amps mode the UP and DOWN arrows increase or decrease the magnitude of the applied load by 5% (coarse), 1% (medium) or 0.2% (fine) of the full-load power defined in the Configuration Menu, whilst maintaining the power factor at its current value. If a 300 kVA generator is being used this means the load will be changed by 15 kVA, assuming that kVA is the current display mode, every time the UP or DOWN arrow is pressed in coarse mode.

Similarly, in Amps or kVA mode, the LEFT and RIGHT arrows decrease or increase the Power Factor by 0.05 (coarse), 0.01 (medium) or 0.002 (fine) each time they are pressed whilst maintaining the magnitude of the applied load.

When the loadbank is operating in kW mode the action of the arrow keys is somewhat different, allowing direct control of either the resistive or reactive components of the load. Pressing the UP and DOWN arrows will change the resistive part of the load by 5%, 1% or 0.2% (depending upon the selected resolution) of the total resistive full-load power. The reactive load does not change which means the power factor will also alter.

When the LEFT and RIGHT arrows are used in kW mode they act only upon the reactive part of the load. The RIGHT arrow will increase the amount of kVAR being applied so as to increase the apparent load by 5%, 1% or 0.2% of the total full-load power specified in the generator set-up menu. Similarly the LEFT arrow will reduce the kVAR by an amount to affect a reduction of 5%, 1% or 0.2% of the total apparent power being drawn from the generator.

It will of course be realised that in any operating mode the LEFT and RIGHT arrows will have no effect upon resistive-only loadbanks as these have no reactive component to apply.

Once a load has been trimmed in this manner it can be learnt as described above.

To summarise, the loadbank will initially calculate a load, which when applied may not draw the desired power. The operator can use either the Load Adjustment or Trim facility to bring the load to that required and then this corrected load can be learned. Next time the preset is called upon, the learned-load is applied and this should be close to the desired value.

As an example, the screen below shows a nominal load of 50% FL at 0.8 PF that has had to be reduced using the trim facility to give the correct load on the generator because of the presence of an external load. This load has been learned to allow it to be applied correctly when next used.

```
02: 150kVA @ 0.80PF
      00:02:36 (L)
      415.3 Volts
      139 kVA   112 Amps
      192 kW    82 kVAr
      50.1 Hz   0.82 PF
      46.1 % kVA
      ENTER for Adjust
```

7.0 Automatic Preset Loads

This mode is very similar to the Manual Preset Loads mode described previously. The difference is that the computer initiates each load change after a specified duration. Preset loads are sequenced through in numerical order to form a load profile, from the starting preset to the terminating preset.

When this mode is selected from the Main Menu the screen shown below is displayed.

```
Profile Definition

Profile: 01 - 10 inc
Auto Adjust is ON
Select function
>1 View Presets
 2 Set First Preset
 3 Set Last Preset
```

The first option on the sub-menu allows all twenty presets to be viewed to determine the starting and terminating presets that will define the profile. This screen is similar to that shown when selecting a Manual Preset, but with the addition of a duration column. It is shown below.

```
FL: 300kVA @ 0.80PF
M: 50% FL @ 0.40 PF

>01 25%FL @ 0.80 PF
    for 00:10:00
 02 50%FL @ 0.80 PF
    for 00:10:00
```

Options two and three on the menu allow the first and last presets that will form a profile to be specified. The presets will be executed in numeric order from the starting preset to the terminating preset inclusively.

Option four is used to toggle the automatic Load Adjustment facility. Each time a preset is applied in automatic mode the computer can initiate the Load Adjustment facility to ensure the applied load is accurate. This is not done if the preset includes an M-Test load as these tests are of short duration. The third line of the display shows if automatic Load Adjust is currently enabled or disabled.

Once the profile has been defined option five on the menu is selected. The profile defined is shown together with the total time that will be required to run the test. If the operator wishes, the ARROW keys can be used to scroll through the list of presets that make up the profile.

This load profile screen is reproduced below.

```
FL: 300kVA @ 0.80PF
M: 50% FL @ 0.40 PF

Total Time: 04:00:05
ENTER to Start

>01 25%FL @ 0.80 PF
for 00:10:00
```

Pressing ENTER will start the test. The operator will be asked if the test results should be output to a printer. Once started the first preset in the profile is applied and will run for the specified duration. The next preset load will then automatically be applied and each subsequent preset load until the end of the defined profile is reached.

Once on-load, the facilities and features are the same as those described in the previous section on Manual Presets with one exception. This exception is that the LOAD key cannot be used to set-up a new load, as it is the function of the computer to perform load changes during Automatic Preset operation.

Having completed the test profile the computer sheds the entire load and returns to the Main Menu.

8.0 Search Mode

This mode of operation is different from those previously described. The purpose in those modes was to apply a step-load to the equipment under test to ensure it had the capacity to provide the required power. In search mode the load can be freely manipulated by the operator to hunt for inconsistencies or critical nodes throughout the range of the equipment under test.

When Search Mode is entered the standard on-load display screen is shown immediately and there is initial starting load of zero kVA at unity power factor.

The size and power factor of the load are manipulated using the arrow keys in the same way as described in the Load Adjustment sub-section of the Manual Presets part of this manual. Any load can be achieved up to the Full-Load Tolerance, programmed in the Configuration Menu, with any power factor from zero to unity assuming the loadbank has the capacity to provide the load.

The step size of each increment is determined by the resolution and this can be altered using the TRIM key. The operator is reminded that the arrow keys operate on the load in a different way when the loadbank is in kW mode from when it is in Amps/kVA mode. Please refer to the description of Load Adjustment discussed previously for full details.

There is provision for seven nodes to be stored in non-volatile memory and these are entirely separate and independent from the Preset Loads discussed so far. When a point of interest is reached the load details can be stored as one of these nodes. The LEARN key is used to display a list of the currently stored nodes and the user is requested to select one of these to be overwritten with the current load.

```
FL: 300kVA @ 0.80PF

Pick Node to Update

>1 27%FL @ 0.83 PF
 2 57%FL @ 0.47 PF
 3  0%FL @ 1.00 PF
 4  0%FL @ 1.00 PF
```

By pressing the UNITS key the loads can be expressed as percentages of the different load units.

Once the node to be overwritten is selected the operator is asked to confirm that this is correct before the old value is destroyed. The load is displayed in both the current units and as a percentage of the currently defined generator full-load.

This screen is shown below.

```
Node 1 will be
Overwritten with the
Load details below.

75 kVA @ 0.76 PF
25%FL kVA @ 0.76PF

ENTER to Confirm
```

To recall and apply a previously stored node the LOAD key is used to call-up a menu of the seven nodes and the user is prompted to select one to use.

```
FL: 300kVA @ 0.80PF

Select Load to Use

>1 27%FL @ 0.83 PF
2 57%FL @ 0.47 PF
3 0%FL @ 1.00 PF
4 0%FL @ 1.00 PF
```

The DUMP key does **not** function as a panic button in this mode as the operator has direct control of the load anyway.

The Load Adjustment feature is available to alter the load until the target load displayed at the top of the screen is achieved.

To end the Search Mode operation and return to the main menu press the CANCEL key twice.

9.0 Loadbank Shutdown

Once all tests have been completed the loadbank may be shut down. This is done using option six on the Main Menu to run the shutdown sequence. When this option is selected the loadbank will run for up to four minutes with no load applied to ensure that the system is adequately cooled before the fans are turned off. The actual duration of the shutdown sequence is variable as the four minutes cooling time is taken from when the loadbank was last on-load. During this time the screen shown below will be displayed.

```
ECLIPSE LOAD SYSTEM

Shutdown Sequence

Do NOT remove power!
Cooling Time = 165 S

ENTER to Abort
```

After the cooling period has expired the loadbank fans will stop and the controller displays a message informing the operator that the power supplies to the loadbank can be removed.

```
ECLIPSE LOAD SYSTEM

Shutdown Complete

Power may be Removed
```

It is important that the shutdown sequence is **always** run at the end of testing, before the power is removed.

10.0 Transient Response

When working in Keypad Loads mode or either of the Presets modes the computer will record information about the excursion of the generators output frequency and voltage during each load-change. The maximum and minimum values of voltage and frequency during the last load-change can then be displayed on the HHT100 screen.

10.1 Overview

At each load-change the loadbank computer will monitor and record information from the instrumentation's frequency transducer and one of its six voltage transducers. The user can select the voltage source monitored from one of the three phase-neutral voltage transducers or one of the three phase-phase voltage transducers.

During a load-change readings are taken from the two transducers 25 times every second. This continues for an operator-defined period of time, which can be between two and ten seconds after the load-change. If the next load-change occurs before the duration of the transient monitoring has been reached, the data from the current load-change is lost and recording of the next load-change transient data commences.

The loadbank computer stores the transient response data from the last load-change in volatile memory and so it is important to realise that the transient data will be lost if the loadbank is powered-down before the transient details are viewed. Transient response data from the last load-change may be viewed by accessing the Transient Menu.

10.2 Transient Menu

The Transient Menu can be accessed in one of two ways. Firstly it is available whilst the loadbank is on-load as the first option from the On-Load Menu. Alternatively, the Transient Menu can be selected when the loadbank is off-load by using the Configuration Menu and selecting the fourth option.

When accessed by either method the display will be as shown below.

```

TRANSIENT MENU

Select parameter :

>1 Analyse Transient
 2 Voltage Source
 3 Capture Period
 4 Load Units

```

The function of each of these options is given below.

Analyse Transient

Selecting the first option from the Transient Menu will allow access to information about the transients during the last load-change. The HHT100 will display the maximum and minimum values that were reached by the voltage and frequency during the load-change and the times after the load application that these values were reached. When this option is chosen the screen below is displayed.

<p>Load-Change 0 kW @ 1.00 PF to 400 kW @ 0.80 PF Max: 254.0V @ 0.4S 59.2Hz @ 1.4S Min: 238.7V @ 0.9S 58.3Hz @ 1.0S</p>
--

Voltage Source

When selected from the Transient Menu this option shows the voltage transducer that is currently being monitored during a load-change and allows the user to select which of the six voltage sources to record during load-changes.

Capture Period

By using this option the operator can enter the duration for which the voltage and frequency are monitored after a load-change. The maximum value is 10 seconds and the minimum value is 2 seconds.

Load Units

This option allows the selection of the units in which the load-change is expressed when this information is displayed on the Transient Analysis screen.

Appendix A Summary of On-Load Error Messages

The computer system in the loadbank performs error checking at two levels. Firstly, it checks that any parameters entered by the operator will not cause a load to be applied that could damage the loadbank or exceed the specification of the power source being tested as defined in the Generator Set-up menu.

Secondly, the loadbank computer will detect errors due to the operating parameters being exceeded or hardware failures.

When an error is detected or an invalid parameter entered, a message will be displayed to the operator giving the reason. Every effort has been made to ensure these messages are as easily understood and self-explanatory as possible, given the limitations of display size.

If a loadbank is continually shutting down with Supply Voltage or Reactor Overload errors it should not continue to be operated as the loadbank operating range limits are being violated. Check the test supply ratings are correct for the specific loadbank being used. Note that if the control system is using an internal supply and this fails then it will not be possible to display an error message.

The error messages that can be produced whilst on-load are listed below, together with a brief description of their cause.

All Load De-allocated	When using multiple loadbanks each will look at its local operating conditions to see if they are legal. If not, that loadbank will shutdown and its contribution to the total system capacity will be de-allocated. It is possible that after several failures all the loadbanks comprising a system are shutdown and the total capacity of the system is zero. If this occurs the test cannot continue so the error message is displayed and the system shuts down.
Communications Error	This message is displayed when a command sent to a remote loadbank is not acknowledged after several re-tries. In this case the communications system is deemed to have failed and the system is shutdown.
Communications Link Lost	If a request for data from a remote loadbank fails after re-tries then this message is displayed. This is then treated as a communications error and the loadbanks will shutdown.
Controller Disconnected	If the control terminal is disconnected or its cable damaged the loadbank(s) are deemed to no longer be under control and so they will automatically shutdown and this message will appear on any printout.

Emergency Stop Detected	This message is produced when the Emergency Stop button is pressed on a slave loadbank. This causes the “running” input to be negated, which is detected by the Eclipse software. All loadbanks will shutdown.
Reactor Overload	When using a reactive load, for any given operating frequency, there is maximum voltage above which the current flowing through the reactor will become excessive. When this voltage is reached this error message is displayed. The limiting voltage is calculated by reading the current operating frequency and using the reactor gradient value to calculate the maximum safe voltage, which must not be exceeded. This error is only generated when a reactive load is being used i.e. the power factor is less than unity. Error checking for this condition is performed even if “Nominal Values” have been selected. This error does not cause a loadbank to shut down once it has shed its load. The next time a load is applied the loadbank will go back on-load.
Loadbank Cooling Fault	A loadbank is not getting sufficient cooling airflow. This may be due to fan failure or blockage of the air intake vents. This error is not considered fatal to a multiple loadbank system.
Supply Voltage too High	The maximum supply voltage has been exceeded. This will cause the loadbank that has detected the problem to shed its load but it does not shutdown. The next time a load is applied the loadbank will go back on-load. This condition is tested for even if “Nominal Values” have been selected for use.
Supply Voltage too Low	The supply voltage has fallen below the minimum requirement. This will cause the local loadbank to go off-load when using multiple loads modules but it does not shutdown. The next time a load is applied the loadbank will go back on-load. This condition is not tested for when using “Nominal Values”.

Appendix B Summary of Key Functions when On-load

This section gives a summary of the function of all the keys that can be used when the loadbank is on-load and highlights in which of the four modes they are applicable.

ENTER	This key is used to start and stop automatic Load Adjustment of a load. In Keypad Loads and Manual Presets modes, if there is a new load set-up this key will apply it.
CANCEL*	This key is used to shed all load, terminate the test and return to the Main Menu in all modes.
LOAD	This is used to set-up a new load either from keyboard entry or menu selection, depending on mode. It does not operate in Automatic Preset mode as the loads are changed under computer control.
LEARN*	This key is used to learn the currently applied load. It is applicable in Manual and Automatic Preset modes, where the load is stored with the rest of the preset details, and in Search Mode it offers a menu of nodes to overwrite. This does not operate in Keypad Loads mode.
DUMP*	This is used as a panic button to reduce the applied load by 25%. It does not operate in Search Mode.
MENU	In all modes this will display the On-load Menu.
TRIM	Used to enable the trim facility in Manual and Automatic Presets modes, and cycle through the available resolutions of 5%, 1% and 0.2% of full load in Preset and Search modes. It does not operate in Keypad Loads.
UNITS (F5)	When a load or preset is displayed or to be entered pressing this button repeatedly will step through each of the units that loads can be represented in; Amps, kVA and kW.
PHASE (F4)	Used to toggle the HHT100 screen between displaying load totals and displaying the individual powers and currents in each phase.
UP Arrow	Increases the percentage full load by the displayed trim resolution in Amps/kVA mode and increases the resistive load component in kW mode. It does not operate in Keypad Loads.
DOWN Arrow	This will decrease the percentage full-load by the displayed trim resolution in Amps/kVA mode and decreases the resistive load component in kW mode. It does not operate in Keypad Loads.

- LEFT Arrow This decreases the power factor by the displayed trim resolution in Amps/kVA mode and decreases the reactive load component in kW mode. It does not operate in Keypad Loads.
- RIGHT Arrow Increases the power factor by the displayed trim resolution in Amps/kVA mode and increases the reactive load component in kW mode. It does not operate in Keypad Loads.

A double-strike feature is used to protect the keys marked * from accidental operation.

Appendix C Quick Start Guide

This section is intended as an introduction to the essential procedures to get an Eclipse loadbank up and running to level where it can be used to apply loads either manually or sequenced by the computer. It should not be regarded as a substitute for reading the full manual. Instead this section should be used in conjunction with the full manual, which gives greater detail on the basic operating modes together with information about the advanced features available from the computer control system.

C.1 Setting Up

The HHT100 terminal should be connected to the Control Terminal socket on the loadbank using any necessary extension cables.

If there is more than one loadbank being used then they should be daisy-chained to the first loadbank using the communications cables supplied for this purpose. Each loadbank is fitted with two inter-module connection ports (A & B) and either or both ports may be used to form the chain.

The cooling fans and control system require a power supply to operate. This supply can be derived from the equipment on test or a separate independent source. Check the ratings plate on the specific loadbank(s) being used for information about the voltage and frequency range that will be suitable for the control system supply. It is preferable to run the loadbank(s) from a stable external power supply where possible.

The loadbank switches should be set appropriately:

Emergency Stop	Pulled Out
Voltage Selector	Set to Test Voltage if no Auxiliary Supply being used Set to external Auxiliary Supply voltage if available
Internal/Off/External	Set to select power source for loadbank control system

Switch the test-supply through to the loadbank(s) and turn on the auxiliary power supply if one is being used.

C.2 Start Up

Once powered up the loadbank will perform its start-up sequence. Read the display and respond to the prompts to work through this sequence. Note – due to the limited number of lines on the HHT100 display it is sometimes necessary to scroll the display up and down using the ARROW keys to display all the information available.

During the start-up sequence the display will show the total capacity of the loadbanks connected to controller and the operating limits of the loadbank. The loadbank protection system will automatically reject load if these values are exceeded. If the limits are not suitable for the required testing please contact *Crestchic*.

The start-up sequence gives the option of starting the cooling fans. If this option is chosen there will be a short delay whilst each of the fans in the loadbank(s) starts in progression.

The operator is then asked to specify the parameters for the supply being tested. It is important that this information is correctly entered, as it is these values that the loadbank software uses to protect the supply from overload. The generator ratings screen is shown below.

```
GENERATOR RATINGS
V & Hz : 415V 50Hz
100% FL: 300 kVA
@ : 0.80 PF
FL Tol : 110 %
Calcs : Instruments
ENTER to Continue
or CANCEL to Edit
```

Press the UNITS key to see the load expressed in Amps, kW or kVA. Press the CANCEL key to edit the test supply parameters. Once the test supply has been correctly specified then press ENTER to continue the start-up sequence.

If there are any Learned Loads in the computer memory the display will show a screen asking if these are still valid or if they should be erased. Normally at the start of a new job any existing Learned Loads should be erased.

This completes the start-up sequence and the Main Menu is displayed.

```
ECLIPSE LOAD SYSTEM

Select function:

>1 Keypad Loads
2 Manual Pre-Sets
3 Auto Pre-Sets
4 Search Mode
```

C.3 Keypad Loads

This mode allows loads to be directly entered by the operator using the controller keypad. Select option 1 from the Main Menu to enter this mode.

The screen will prompt for the size of load that is required. To change the units in which the load is entered (Amps, kW or kVA) press the UNITS key. Once the load is input press ENTER to accept it. If prompted enter the required Power Factor for the load. The load will then be displayed on the screen. If it is correct press ENTER to confirm the load or CANCEL to re-enter the values.

The screen will now display the instrumentation values but the new load will not yet have been applied. When ready press the ENTER key to apply the entered load. The on-load instrumentation screen is shown below. There are two modes – total-values and phase-values. These are shown on the left and right respectively. To toggle between the display modes press the PHASE key.

Ld: 150kVA @ 0.80PF 00:00:21 415.2 Volts 150 kVA 209 Amps 122 kW 86 kVA_r 50.1 Hz 0.81 PF 50.1 % kVA ENTER for Adjust	Ld: 150kVA @ 0.80PF 00:00:21 415.2 V R 50 kVA 415.1 V S 50 kVA 415.2 V T 50 kVA 50.1 Hz 0.81 PF 50.1 % kVA ENTER for Adjust
--	--

To change the load press the LOAD key and enter the new load details as before. To shed the load and finish the test press the CANCEL key.

When on-load the Load Adjustment feature is available by pressing the ENTER key. This will adjust the applied load as accurately as possible to meet the requested values.

A summary of the keypad buttons in this mode is given below:

LOAD	Specify new load
CANCEL	Shed ALL load and return to Main Menu (double-stroke)
DUMP	Reduce applied load by 25% (double-stroke)
ENTER	Automatic Load Adjustment
PHASE	Toggle display mode
UNITS	Select and display load in different units (Amps, kW, kVA)

C.4 Manual Preset Loads

Up to twenty loads can be memorised by the loadbank. These are programmed from the Configuration Menu and details of how this can be done are covered in a later sub-section. Any of these preset loads can be applied at the operators command.

Selecting option two from the Main Menu enters the Manual Presets Mode. This causes a list of available presets to be displayed. Use the ARROW keys to scroll through the list and when the desired preset is reached press ENTER. Alternatively enter the preset number on the keypad and press ENTER.

FL:	300kVA	@	0.80PF
M:	50% FL	@	0.40 PF
Select a Preset			
	%FL	@	PF
>01	25	@	0.80
02	50	@	0.80
03	75	@	0.80
04	100	@	0.80

Once a preset has been selected the display will ask for the load to confirmed and once this is done the instrumentation screen will be displayed. To apply the preset load press the ENTER key again.

To change the load to another preset press the LOAD key and select the next load as described above. To shed all load and finish the test press the CANCEL key. The Load Adjustment feature described in the Keypad Loads sub-section is also available in this mode. Press the ENTER key to start the automatic adjustment.

In Manual Presets Mode a trim feature is available to allow the operator to adjust the applied load using the ARROW keys. Press the TRIM button to commence the trim function and repeatedly press it set the desired resolution to coarse ($\pm 5\%$), medium ($\pm 1\%$) or fine ($\pm 0.2\%$). The trim applied depends upon the units that the system is currently operating in. The table below shows the trim effect in different modes.

	KVA/Amps Mode	KW Mode
UP ARROW	Increases load magnitude Retains the power factor	Increases resistive component of applied load
DOWN ARROW	Decreases load magnitude Retains the power factor	Decreases resistive component of applied load
LEFT ARROW	Decreases the power factor Load magnitude unaffected	Increases reactive component of applied load
RIGHT ARROW	Increases the power factor Load magnitude unaffected	Decreases reactive component of applied load

Once a load has been applied from the list of presets and adjusted to the required value by either the automatic Load Adjustment or the Trim facility it can be learned by pressing the LEARN key. If that preset is called up again the loadbank will not calculate the load elements required but will switch in adjusted load that was learned previously.

Learned loads can be further adjusted and the new value learned in the same way.

A summary of the keypad buttons in this mode is given below:

LOAD	Display list of presets to select a new load
CANCEL	Shed ALL load and return to Main Menu (double-stroke)
DUMP	Reduce applied load by 25% (double-stroke)
ENTER	Automatic Load Adjustment
PHASE	Toggle display mode
UNITS	Select and display load in different units (Amps, kW, kVA)
TRIM	Enable Trim facility and set resolution
LEARN	Store the adjusted load for a preset (double-stroke)

C.5 Automatic Presets

When the preset loads are programmed into the loadbank memory duration can also be input together with the other load parameters. This mode allows a sequence of preset loads to be applied under control of the loadbank computer for the specified duration of each load.

The Automatic Presets Mode is entered by selecting option 3 from the Main Menu at which point the following screen is displayed.

```
Profile Definition

Profile: 01 - 10 inc
Auto Adjust is ON
Select function
>1 View Presets
 2 Set First Preset
 3 Set Last Preset
```

Selecting options from this screen will allow the list of available preset loads and their durations to be viewed, the starting and terminating presets for the load-profile sequence to be set-up and the Load Adjustment feature to be activated automatically after each load-change. Once the sequence has been set-up the selected profile will be accepted by selecting option 5 from the menu given in the screen above.

The display will show the profile details for review and this load sequence can be started by pressing the ENTER key. Once all loads in the sequence have been applied for their specified durations all load will be shed and the system will return to the Main Menu screen.

All keys operate as described in the previous sub-section with the exception of the LOAD key. This is now disabled, as it is the computers responsibility to sequence the load changes.

C.6 Search Mode

This mode allows free adjustment of the applied load and power factor using the Trim feature described in the Manual Preset Loads sub-section.

This mode is selected from option 4 of the Main Menu. It immediately displays the on-load instrumentation screen with no load applied. The load can be manipulated using the TRIM and ARROW keys.

A specific load condition (node) can be stored for future retrieval. When running at the desired load press the LEARN key. The list of seven nodes that can be stored will be displayed. Follow the screen prompts to store the currently applied load in the desired node location. Previously stored nodes will be overwritten with the new load details.

To apply a previously stored node press the LOAD key and select the load form the list of seven nodes. Confirm the selection and then press ENTER to apply the new load. This process can be repeated as required.

A summary of the keypad buttons in this mode is given below:

LOAD	Display list of nodes to select a new load
CANCEL	Shed ALL load and return to Main Menu (double-stroke)
ENTER	Automatic Load Adjustment
PHASE	Toggle display mode
UNITS	Select and display load in different units (Amps, kW, kVA)
TRIM	Set Trim resolution
LEARN	Store the applied load in a node
ARROW keys	Manipulates load as described in Trim mode

C.7 Configuration Menu

If it is intended to only operate in Keypad Loads or Search Mode then no set-up is required from this menu. All other modes operate with loads specified using options from this menu.

The first three options from this menu are the ones that are important for basic operation of the loadbank. Other options from this menu should not normally require alteration except in special circumstances.

To enter the Configuration Menu select option five from the Main Menu. This will produce the display reproduced below.

```
          CONFIG MENU

    Select parameter :

    >1 Generator Setup
      2 Program Pre-Sets
      3 Program M-Test
      4 Transient Values
```

Option 1 – Generator Set-up

Follow the screen prompts and enter the nominal voltage and frequency it is expected will be output from the supply to be loaded.

Next select the 100% Load Power option and enter the normal full load rating of the generator. Use the UNITS key to select the appropriate units (Amps, kW or kVA) that this is expressed in.

Then select and enter the maximum full-load tolerance. This is the desired maximum load that the loadbank is to draw from the test supply, expressed as a percentage of the full-load entered above.

Finally, select if you wish the loadbank to use its measured instrumentation values or the nominal values entered above when it calculates its load parameters. Generally the use of instrumentation values gives more accurate results as the loadbank can take into account the effect of loading on the generators output voltage and frequency.

Option 2 – Program Presets

When selected this option will display a partial list of presets as shown below. Use the ARROW keys to scroll through the entire list of twenty presets and select a preset for editing.

```
FL:  300kVA @ 0.80PF
M:   50% FL @ 0.40PF

    Select a Preset
      to Edit:

    >01  25%FL @ 0.80 PF
        for 00:10:00
```

Pressing ENTER will display that preset's parameters.

Use the sub-menu for that preset to enter the percentage of full-load, the power factor and duration (if it is to be used in automatic mode). The sub-menu also provides an option to add the M-Test Load to the base preset to provide a composite load when this preset is applied. When the preset editing screen is displayed the UNITS key can be used to display the load in the correct percentage of full-load – i.e. % FL Amps, % FL kW or % FL kVA.

The preset editing screen is reproduced below.

```
FL: 300kVA @ 0.80PF
01: Base Load Only
      %FL @ PF
Base : 25 0.80
Total: 25 0.80
For : 00:10:00
      Value to alter
>1 Base Load
```

Press CANCEL to return to the list of presets and select another for further editing or press CANCEL again to return to Configuration Menu.

Option 3 – Program M-Test

The M-Test load is usually a low power factor load that simulates a motor starting current. It is usually applied for a short duration in addition to a specific base load condition.

Select this option and follow the screen prompts to set up the load and power factor of the M-Test load. Press the CANCEL key to return to the Configuration Menu once the load has been defined.

C.8 Shutdown Loadbanks

This option is item six on the Main Menu. When selected this option will initiate the loadbank shutdown sequence.

Once this sequence commences the fans will run for up to 240 seconds to ensure the loadbank elements are at a sufficiently low temperature before the cooling fans are stopped and the loadbank power is removed.

During the shutdown sequence the HHT100 screen will display the countdown and allow the shutdown to be aborted by pressing the ENTER key.

Once the cooling period has expired the fans will stop and the loadbank may be powered down.

Appendix D Glossary

This section defines terms used throughout this document.

Automatic Preset Mode	The test mode where a profile of different loads is sequenced automatically by the computer.
Base Load	The nominal value of a Preset Load before any M-Test Load is added to it.
Complex Load	A load that has a true power magnitude (kW) and power factor. All Preset Loads are expressed as complex loads.
Composite Load	This is the sum of two Complex Loads. The load resulting from adding an M-Test load to a Preset is a Composite Load.
Dynamic Sensing	This is the measuring of voltage and frequency values at the loadbank. These values are then used in the calculation of a new load.
FL	see Full Load
Full Load	This is the 100% nominal rating of the equipment under test.
Full-Load Tolerance	The maximum percentage of the full load power that the loadbank is permitted to draw.
Generator Set-up Menu	This is a sub-menu under the Configuration Menu where all the parameters defining the equipment under test are grouped. All these parameters must be correctly set for the generator being used if the loadbank software is to protect the generator from excessive loads.
HHT100 Controller	This is <i>Crestchic's</i> own custom-designed hand-held electronic loadbank control module.
ILS	This is the Initial Load Signal. It is used internally by the computer as a representation of the amount of resistive and reactive load.
Keypad Load	A load entered by the operator via the keyboard. This is expressed in terms of the desired load current or power and a power factor.
Keypad Load Mode	The test mode where loads entered by the operator via the keyboard are applied.

kVA	This is the total apparent power. This is the complex sum of resistive and reactive components of power.
kVAr	This is the reactive part of the total power.
kW	This is the resistive part of the total power, sometimes called true power.
Learned Load	An adjusted or trimmed Preset Load that has been stored by the operator. When this Preset Load is next used the adjusted load will be applied rather than a calculated one.
Load Adjustment	This is used to alter the applied load to compensate for inaccuracies between a calculated load and the requested load.
Load Profile	See Profile
Manual Preset Mode	The test mode where pre-programmed load are selected by the operator. The Preset Loads can be used in any order and at any time.
Master Loadbank	When using multiple loadbanks the master loadbank is the module that the controller is connected to. There should only be one controller connected to each system of loadbanks i.e. only one master.
M-Test	This is used to add an additional worst-case load to a Preset Load to provide an overload test.
M-Test Load	This is a Complex load that represents a worst-case load used during an M-Test.
Nominal Values	These are values for the nominal voltage and frequency rating of the equipment under test. They are used for load calculations and are entered by the operator from the keyboard.
PC	Personal Computer. This is the notebook computer used as the operator interface to control the loadbank.
PF	Power Factor
Preset Load	A Complex load that has been previously programmed. Preset loads are retained in non-volatile memory.
Profile	A number of Preset Loads applied sequentially to test the load-change performance of the equipment under test.

Search Mode	The test mode where the operator using the Arrow keys directly manipulates the applied load. It is used to search for critical nodes of operation of the equipment under test.
Slave	When using multiple loadbanks a slave module is one that is not controlled directly by the operator but takes its instructions from a remote master loadbank.
Transient	The excursion of voltage and frequency that occurs when the load on a generator is changed.
Trimmed Load	This is a Preset load that has been manipulated by the operator using the Arrow keys. A trimmed load may be learned.
Trim Resolution	The amount by which an applied load is altered by a press of an Arrow key. This can be Coarse (5% of FL, 0.05 change in PF), Medium (1% of FL, 0.01 change in PF) or Fine (0.2% of FL, 0.002 change in PF).



Crestchic Loadbanks
WORLDWIDE LOADBANK SPECIALISTS

10. PARTS LIST

PARTS LIST 3.3MVA MICRO C3381

MODEL	3.3MVA			CONTRACT No.	C3381			
RATING	3.3MVA			ISSUED	2			
TEST SUPPLY	380V-480V, 50/60Hz, 3-PHASE, 4-WIRE			DATED	07/06/2006			
CONTROL SYSTEM	MICRO			SIGNED	MP			
ENCLOSURE TYPE	10ft CONTAINER			No. of SHEETS	5			
ITEM	CIRCUIT REF	STOCK	DESCRIPTION	MANUFACTURERS REF	No.	ORDER No.	REC.	ISS.
1	CL11681		GENERAL ARRANGEMENT		REF			
2	CL11682		WIRING DIAGRAM		REF			
3	CL11174		COMPUTER CONNECTION DETAILS		REF			
4	CL6660		ANTI-CONDENSATION HEATING & LIGHTING		REF			
5	CL8094		ENVIRONMENTAL CHAMBER		REF			
6	CL11677	ENC753	ENCLOSURE 3300kVA - 10ft		1			
7	CL11679		ELEMENT MOUNTING PLATE AND RAILS		1 set			
8	CL11791		BUSBAR END PLATE	CL11791 Issue 1	1			
9	CL11573		CONTROL FACIA (SUPPLY)	CL11573 Issue 1	1			
10	CL11177	LAB190	CONTROL FACIA MIL. TYPE (CONTROL)	CL8202 / CL11177	1			
11								
12		ASS270	ENCLOSED SOLAR MICRO CONTROL SYSTEM 48	PL1301	1			
13								
14								
15								
16								
17			ECLIPSE SOFTWARE		1			
18			TRANSVIEW SOFTWARE		1			
19			ENVIRONMENTAL CHAMBER AIR-CON	PL1229	1			
20			10FT REACTOR COOLING SYSTEM	PL1287	1			
21								
22	FANA-FANH	FAN321	FAN 63JM S/C 380/480V 50/60Hz 3PH 1420RPM 4.4	63JM/25/4/9/36 (F2249B)	6			
23	FAN R1	FAN153	400mm 2101 FAN 380/480V 50/60Hz 3 PHASE 0.31	2101/400-BT9	1			
24								
25		ELE187	ELEMENT 1110W 277V		18			
26		ELE345	ELEMENT 5555W 277V	400825	480			
27								
28		REA101	REACTOR 1.98kVAR 440V 3 PHASE 50Hz		1			
29		REA102	REACTOR 3.96kVAR 440V 3 PHASE 50Hz		2			
30		REA103	REACTOR 7.92kVAR 440V 3 PHASE 50Hz		1			
31		REA104	REACTOR 19.8kVAR 440V 3 PHASE 50Hz		1			
32		REA105	REACTOR 39.6kVAR 440V 3 PHASE 50Hz		1			
33		REA106	REACTOR 79.2kVAR 440V 3 PHASE 50Hz		1			
34		REA108	REACTOR 158.4kVAr 440V 3 PHASE 50Hz		1			
35		REA109	REACTOR 280.0kVAR 440V 3 PHASE 50Hz		6			
36	TX1	TRX751	TRANSFORMER 5kVA PRIM 380,400,415,440,480V	BWS	1			
37			I/P 380,415,440,480:220V 50/60Hz, 1-PHASE					
38	CR0-CR4							
39	RL3,CX0-CX4,CR	CON880	CONTACTOR 35A 3 POLE (4kW) 230V 50/60Hz	3RT10231AL20	12			
40	FCA-FCR	CON881	CONTACTOR 35A 3 POLE (5.5kW) 230V 50/60Hz	3RT10241AL20	7			
41	CR5,6	CON884	CONTACTOR 45A 3 POLE (15.0kW) 230V 50/60Hz	3RT10341AL20	2			
42	CX5	CON885	CONTACTOR 55A 3 POLE (18.5kW) 230V 50/60Hz	3RT10351AL20	1			
43	CR7	CON887	CONTACTOR 90A 3 POLE (30.0kW) 230V 50/60Hz	3RT10441AL20	1			
44	CX6	CON890	CONTACTOR 140A 3 POLE (55.0kW) 230V 50/60Hz	3RT10541AP36	1			
45	CX7	CON893	CONTACTOR 250A 3 POLE (110.0kW) 230V 50/60Hz	3RT10646AP36	1			
46	CX8-CX13	CON896	CONTACTOR 400A 3 POLE (200.0kW) 230V 50/60Hz	3RT10756AP36	6			
47	CR8-CR22	CON902	CONTACTOR AC1 250A 3 POLE 230V 50/60Hz No	3RT14566AP36	15			
48	AC/MC,SCF/SCF	CON927	CONTACTOR 80A 3 POLE C/O 230V 50/60Hz	3RA13458XB30-1AL2	2			
49	FCA-FCF	CON946	AUXILIARY CONTACT SIDE MOUNTED 1 NO 1 NC	3RH1921-1DA11	10			
50	SCF/R,AC/MC							
	FORM	CF012	CRESTCHIC LIMITED	PHONE +44 (0) 1283 531645				
	ISSUE	08	2ND AVENUE, CENTRUM 100,	FAX. +44 (0) 1283 510103				
	ISSUE DATE	16/11/05	BURTON ON TRENT, STAFFS	www.crestchic.co.uk				
	AUTHORISED	M.W.B.	UNITED KINGDOM DE14 2WF	sales@crestchic.co.uk				

PARTS LIST 3.3MVA MICRO C3381

MODEL	3.3MVA		CONTRACT No.	C3381				
RATING	3.3MVA		ISSUED	2				
TEST SUPPLY	380V-480V, 50/60Hz, 3-PHASE, 4-WIRE		DATED	07/06/2006				
CONTROL SYSTEM	MICRO		SIGNED	MP				
ENCLOSURE TYPE	10ft CONTAINER		No. of SHEETS	5				
ITEM	CIRCUIT REF	STOCK	DESCRIPTION	MANUFACTURERS REF	No.	ORDER No.	REC.	ISS.
51			BROUGHT FORWARD					
52	FCR,CR0-CR4							
53	RL3,CX0-CX4							
54	FCA-FCF, CR	CON950	SUPPRESSOR CAPACITOR SIZE 102	3RT1926-1CD00	19			
55	CX5,CR5-7	CON951	SUPPRESSOR CAPACITOR SIZE 103-104	3RT1936-1CD00	8			
56	SCF/R,AC/MC							
57	OTHER COILS	CAP527	CAPACITOR 1000V 0.1uF	FEC 106-367 / 952-0341	23			
58								
59	OLA-OLR	OLR131	OVERLOAD RELAY 7.0-10.0A	3RU1126-1JB0	7			
60								
61	RELAY 1	RLY302	LOGO! 230RC - SIEMENS	6ED1 052-1FB00-0BA5	1			
62	RELAY 1	RLY303	LOGO! DM8 230R - SIEMENS	6ED1 055-1FB00-0BA1	1			
63	RL1	RLY202	RELAY BASE 11-PIN	LZX-MT78750	1			
64	RL1	RLY154	RELAY 10A 3PCO 11-PIN 230V AC COIL	LZX-MT326230	1			
65								
66	EM-STOP	SWT140	PUSH BUTTON ASSEMBLY 1xNO 1xNC	ZB4-BZ105	1			
67	EM-STOP	SWT159	MUSHROOM HEAD PULL PUSH	ZB4-BT4	1			
68	EM-STOP	SWT152	AUXILIARY CONTACT BLOCK 1 N/C	ZBE-102	1			
69								
70	AF1-AF6	SEN103	AIR FLOW SWITCH	XCK-P154-H29	6			
71	AF1-AF6	SEN104	AIR FLOW SUPPORT BRACKET	CL6472-1	6			
72	AF1-AF6	SEN105	AIR FLOW PADDLE	CL6472-2	6			
73	AF1-AF6	SEN106	AIR FLOW PADDLE CLAMP	CL6472-1	6			
74								
75	TEMP. SEN.	SEN153	THERMAL SWITCH 90 DEG N/C	RS 331-528	4			
76		WAC283	CABLE GLAND M16 7-10.5 BLACK	FEC 143-608	16			
77		CAB383	CABLE 3 CORE SILICON SIAF 1.5mm		6m			
78								
79	PSF,PSR	SEN171	PHASE ROTATION RELAY 500 VOLTS	FEC178-871 / 3UG4513-1BR2	2			
80	SW1	SWT303	SWITCH 4 POLE 3 POSITION (20A)	CA10-A213-620EF	1			
81	SW2	SWT312	SWITCH 1 POLE 2 POSITION (20A)	CA10-A220-600EF	1			
82	SW3	SWT309	SWITCH 4 POLE 2 POSITION	CA10-A223-600EF	1			
83								
84								
85								
86								
87								
88								
89	FT1	TML072	FUSE TERMINAL SAKS 1/35	050162	1			
90	FT1	TML111	END PLATE SAKS 1/35	019132	1			
91	FT1	FUH383	FUSE 2A 20 x 5mm	KL 043090	1			
92								
93	F1-F3	FUH158	HRC FUSE LINK 100 AMP	MEM 100SO	3			
94	F100-F102	FUH165	HRC FUSE LINK 125 AMP	LAWSON SSFP125	3			
95	F4-48,103-105	FUH169	HRC FUSE LINK 250 AMP	LAWSON SSB3250	48			
96	F106-F123	FUH172	HRC FUSE LINK 400 AMP	LAWSON SSB4400	18			
97								
98	F1-F3	FUH345	FUSE HOLDER 100 AMP	SC 100H	3			
99								
100								
	FORM	CF012	CRESTCHIC LIMITED	PHONE +44 (0) 1283 531645				
	ISSUE	08	2ND AVENUE, CENTRUM 100,	FAX. +44 (0) 1283 510103				
	ISSUE DATE	16/11/05	BURTON ON TRENT, STAFFS	www.crestchic.co.uk				
	AUTHORISED	M.W.B.	UNITED KINGDOM DE14 2WF	sales@crestchic.co.uk				

PARTS LIST 3.3MVA MICRO C3381

MODEL	3.3MVA			CONTRACT No.	C3381			
RATING	3.3MVA			ISSUED	2			
TEST SUPPLY	380V-480V, 50/60Hz, 3-PHASE, 4-WIRE			DATED	07/06/2006			
CONTROL SYSTEM	MICRO			SIGNED	MP			
ENCLOSURE TYPE	10ft CONTAINER			No. of SHEETS	5			
ITEM	CIRCUIT REF	STOCK	DESCRIPTION	MANUFACTURERS REF	No.	ORDER No.	REC.	ISS.
101			BROUGHT FORWARD					
102								
103								
104	CB1, CB2	CCT158	MCB 3 POLE 25 AMP TYPE B	C60HB325 / 5SY4 325-6	2			
105	CB3, CB4	CCT161	MCB 3 POLE 50 AMP TYPE B	C60HB350 / 5SY4 350-6	2			
106								
107	CB5, CB6	CCT240	MCB 3 POLE 40 AMP M TYPE D	C60HD340 / 5SY4 340-8	2			
108	CB7	CCT242	MCB 3 POLE 63 AMP M TYPE D	C60HD363 / 5SY4 363-8	1			
109	CB50, CB51	CCT304	MCCB 3 POLE 63-80 AMP	3VL27 08-1DC33-0AA0	2			
110	CB61, CB62	CCT224	MCB 2 POLE 32 AMP M TYPE D	C60HD232 / 5SY4 232-8	2			
111	CB63	CCT223	MCB 2 POLE 25 AMP M TYPE D	C60HD225 / 5SY4 225-8	1			
112	CB60, 64-65	CCT152	MCB 3 POLE 2 AMP TYPE B / C	C60HB302 / 5SY4 302-7	3			
113	CB66, CB67	CCT107	MCB 2 POLE 6 AMP	GB2-CD12	2			
114	CB68- CB69	CCT109	MCB 2 POLE 10 AMP	GB2-CD16	2			
115	CB70-75, 82	CCT238	MCB 3 POLE 25 AMP M TYPE D	C60HD325 / 5SY4 325-8	7			
116								
117								
118	CT1-CT3	INS231	CURRENT TRANSFORMER 4000/5A	DKM 50/60Hz	3			
119								
120								
121		COV203	CABLE ENTRY CANVAS POUCH 10ft CONTAINER	CL9439/2	1			
122								
123		FAN370	PANEL FILTER	RS 185-0749	1			
124								
125		LAB160	LABEL CRESTCHIC LOGO	CL6939	1			
126		LAB200	DANGER ELECTRIC SHOCK VYNAL	FEC 152-665	5			
127			RATING PLATE	RP3381.job	1			
128								
129		INU125	BUSBAR CLAMP 3 POLE 1 x 10mm	3603MS	16			
130		INU141	BUSBAR CLAMP SPACER 12.5mm	3SP05	16			
131		INU142	BUSBAR CLAMP SPACER 25.4mm	3SP1	48			
132		INU143	BUSBAR CLAMP SPACER 5mm	3SPM5	16			
133								
134		INU210	TERMINAL BOARD SRBP 775x650x12mm		1			
135								
136								
137		ECL102	ELEMENT HOOKS 160mm STAINLESS STEEL		480			
138		ECL103	ELEMENT HOOKS 340mm STAINLESS STEEL		18			
139								
140		COP036	COPPER TIN PLATED 120 X 10 X 1 METRE		21			
141		COP045	COPPER TIN PLATED 2.5" X 0.25" X 1 METRE		2			
142		COP049	COPPER TIN PLATED 1" X 0.25" X 1 METRE		15			
143		COP060	COPPER TIN PLATED 1.5" X 0.125" X 1 METRE		39			
144								
145								
146								
147		WAC400	EARTH BONDING STRAP 150mm	FEC 108-766	4			
148		WAC401	EARTH BONDING STRAP 250mm	FEC 108-767	9			
149		WAC402	EARTH BONDING STRAP 400mm	FEC 108-768	3			
150								
	FORM	CF012	CRESTCHIC LIMITED	PHONE +44 (0) 1283 531645				
	ISSUE	08	2ND AVENUE, CENTRUM 100,	FAX. +44 (0) 1283 510103				
	ISSUE DATE	16/11/05	BURTON ON TRENT, STAFFS	www.crestchic.co.uk				
	AUTHORISED	M.W.B.	UNITED KINGDOM DE14 2WF	sales@crestchic.co.uk				

PARTS LIST 3.3MVA MICRO C3381

MODEL	3.3MVA			CONTRACT No.	C3381			
RATING	3.3MVA			ISSUED	2			
TEST SUPPLY	380V-480V, 50/60Hz, 3-PHASE, 4-WIRE			DATED	07/06/2006			
CONTROL SYSTEM	MICRO			SIGNED	MP			
ENCLOSURE TYPE	10ft CONTAINER			No. of SHEETS	5			
ITEM	CIRCUIT REF	STOCK	DESCRIPTION	MANUFACTURERS REF	No.	ORDER No.	REC.	ISS.
151			BROUGHT FORWARD					
152								
153								
154		WAC317	LOCKING NUT 25mm	SLN25G	8			
155		WAC331	COMPRESSION GLAND 25mm	DMC125M25	16			
156		WAC369	FLEXIBLE CONDUIT 25mm	DMC225	4m			
157								
158	AUX I/P+V.SENS	ENC835	POLYESTER BOX 170x140x95mm DEEP	RS 119-5597	2			
159	AUX I/P+V.SENS	TML381	TERMINAL 125A 600V	FEC 145-355	7			
160	AUX I/P+V.SENS	TML382	TERMINAL SPACER	FEC 145-370	5			
161	AUX I/P+V.SENS	TML121	END BRACKET EW35	KL 038356	4			
162								
163		TML042	EARTH TERMINAL WPE4	KL 101010	2			
164								
165		TML023	TERMINAL SAK4/35	KL 044366	29			
166		TML103	END PLATE AP	KL 011796	5			
167		TML121	END BRACKET EW35	KL 038356	15			
168								
169		TML153	TERMINAL CROSS CONNECTION QL2	KL 013060	7			
170		TML157	TERMINAL CROSS CONNECTION SLEEVE VH 13.3	KL 024850	26			
171		TML158	TERMINAL CROSS CONNECTION SCREW BS M3X	KL 030300	26			
172		TML155	TERMINAL CROSS CONNECTION QL4	KL	3			
173								
174	MAINS	FIX101	M16 BRASS HEX NUT		34			
175	MAINS	FIX103	M16 BRASS FLAT WASHER		68			
176	MAINS	FIX104	M16 x 50mm BRASS HEX SET		4			
177	MAINS	FIX106	M16 x 70mm BRASS HEX SET		30			
178								
179	12V DC	MIC307	POWER SUPPLY 12V DC	RS 377-7141	1			
180	15V DC	MIC310	POWER SUPPLY 15V DC TYPE ZVC36FS15E	RS 377-7078	1			
181		MIC309	MAINS LEAD 2.5A CLASS 2	RS 452-669	2			
182								
183								
184								
185								
186								
187								
188								
189								
190								
191			BRUSH STRIP (No 4 SECTION)	FORMSEAL LTD	2m			
192			TO PART CODE FS3/40-180°	Tel 01785 284 808				
193				RS 326-9909				
194								
195								
196								
197								
198								
199								
200								
	FORM	CF012	CRESTCHIC LIMITED	PHONE +44 (0) 1283 531645				
	ISSUE	08	2ND AVENUE, CENTRUM 100,	FAX. +44 (0) 1283 510103				
	ISSUE DATE	16/11/05	BURTON ON TRENT, STAFFS	www.crestchic.co.uk				
	AUTHORISED	M.W.B.	UNITED KINGDOM DE14 2WF	sales@crestchic.co.uk				

PARTS LIST 3.3MVA MICRO C3381

MODEL	3.3MVA			CONTRACT No.	C3381			
RATING	3.3MVA			ISSUED	2			
TEST SUPPLY	380V-480V, 50/60Hz, 3-PHASE, 4-WIRE			DATED	07/06/2006			
CONTROL SYSTEM	MICRO			SIGNED	MP			
ENCLOSURE TYPE	10ft CONTAINER			No. of SHEETS	5			
ITEM	CIRCUIT REF	STOCK	DESCRIPTION	MANUFACTURERS REF	No.	ORDER No.	REC.	ISS.
201			BROUGHT FORWARD					
202								
203			THE FOLLOWING ITEMS ARE FOR LIGHTING					
204			AND ANTI-CONDENSATION HEATER					
205								
206		WAC311	BRASS MALE BUSH 20mm	MS20	2			
207		WAC313	BRASS MALE BUSH 32mm		1			
208		WAC318	LOCKING NUT 32mm		1			
209								
210		WAC360	RCD ENCLOSURE STEEL	HAGER IU2	1			
211		WAC361	RCD CIRCUIT BREAKER 25A DP 30mA	HAGER U724*	1			
212		WAC362	SWITCHED FUSE SPUR UNIT 13A	GMC13SSP	2			
213		WAC363	CONDUIT 20mm BLACK PVC x METRE	HG20B	1			
214		WAC364	CONDUIT SADDLES 20mm BLACK	MITASBS20B	3			
215		WAC365	CONDUIT INSPECTION BENDS 20mm BLK	MITAPIE20B	2			
216		WAC366	CONDUIT INSPECTION TEE 20mm BLK		1			
217		WAC367	CONDUIT FEMALE ADAPTOR 20mm BLK	MITAPFA20B	2			
218								
219								
220			CONDUIT ADHESIVE	SA2	1			
221								
222								
223			PLUG FUSES 5A		2			
224								
225		CNR505	CHASSIS MTD PLUG 16A 3 POLE 240 VOLT	PM16-781	1			
226		CNR506	CABLE MTD SOCKET 16A 3 POLE 240 VOLT	PM16-2100	1			
227			230V 50/60Hz OPERATION					
228		FAN425	ANTI-CONDENSATION HEATER 230V 350W	RS 282-1326	1			
229		WAC371	BULKHEAD LIGHT FITTING	BH100G	1			
230		WAC372	LAMP 100 WATTS		1			
231								
232								
233								
234								
235								
236								
237								
238								
239								
240								
241								
242								
243								
244								
245								
246								
247								
248								
249								
250								
	FORM	CF012	CRESTCHIC LIMITED		PHONE +44 (0) 1283 531645			
	ISSUE	08	2ND AVENUE, CENTRUM 100,		FAX. +44 (0) 1283 510103			
	ISSUE DATE	16/11/05	BURTON ON TRENT, STAFFS		www.crestchic.co.uk			
	AUTHORISED	M.W.B.	UNITED KINGDOM DE14 2WF		sales@crestchic.co.uk			



Crestchic Loadbanks
WORLDWIDE LOADBANK SPECIALISTS

11. DRAWINGS – GENERAL ARRANGEMENT

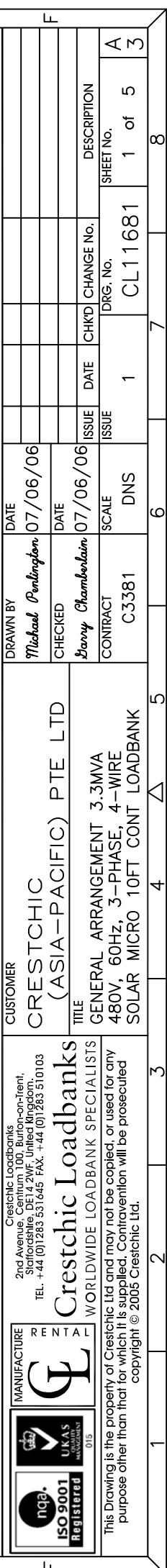
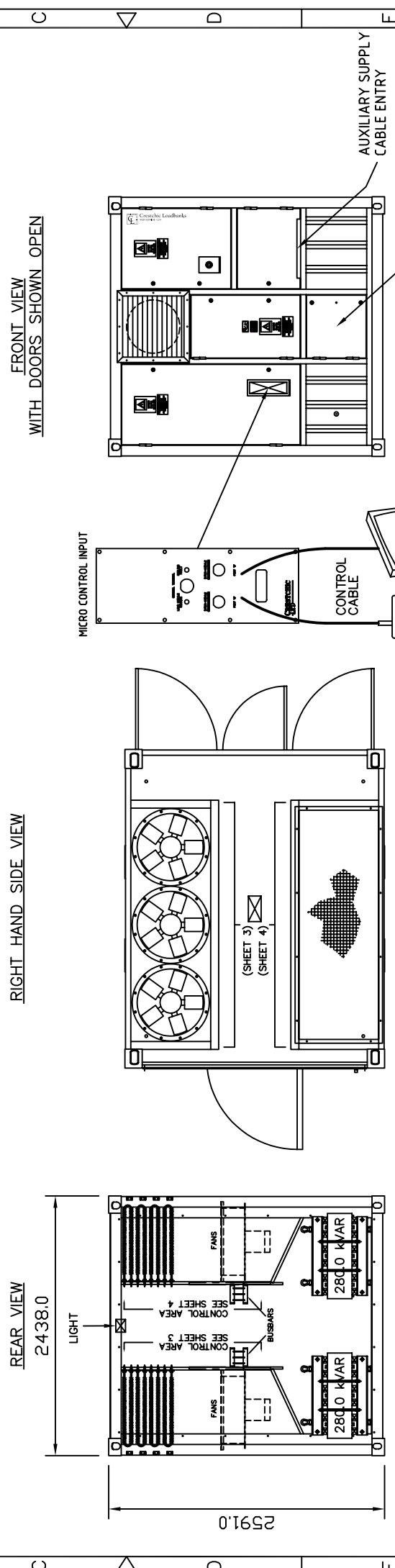
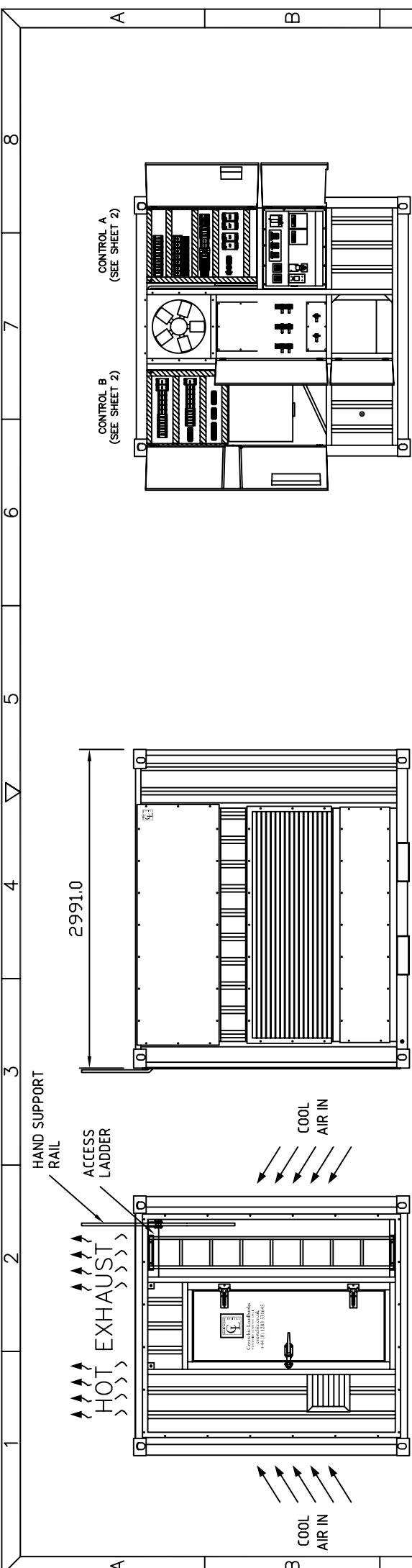

DRAWN BY	DATE	ISSUE	CHANGE No.	DESCRIPTION
Michael Pennington	07/06/06	1	CL11681	1 of 5
CHECKED	DATE	ISSUE	CHANGE No.	DESCRIPTION
Darry Chamberlain	07/06/06	1	CL11681	1 of 5
CONTRACT	SCALE	DNS	DRG. No.	SHEET No.
C3381	DNS	1	CL11681	1 of 5

CUSTOMER	CRESTCHIC (ASIA-PACIFIC) PTE LTD
TITLE	GENERAL ARRANGEMENT 3.3MVA 480V, 60Hz, 3-PHASE, 4-WIRE SOLAR MICRO 10FT CONT LOADBANK

Crestchic Loadbanks
2nd Avenue, Centrum 100, Burton-on-Trent,
Staffordshire, DE14 2WF, United Kingdom.
TEL. +44 (0)1283 531645 FAX. +44 (0)1283 510103

Crestchic Loadbanks
WORLDWIDE LOADBANK SPECIALISTS

MANUFACTURE

UKAS
015

nqa.
ISO 9001
Registered

This Drawing is the property of Crestchic Ltd and may not be copied, or used for any purpose other than that for which it is supplied. Contravention will be prosecuted copyright © 2005 Crestchic Ltd.

1 2 3 4 5 6 7 8

VIEW BEHIND LEFT DOOR
CONTROL 'B'

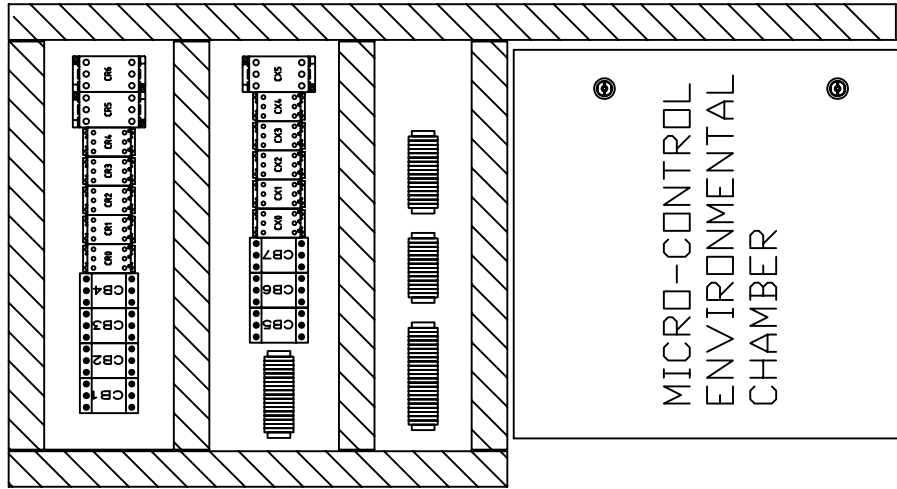

VIEW BEHIND RIGHT DOOR
CONTROL 'A'

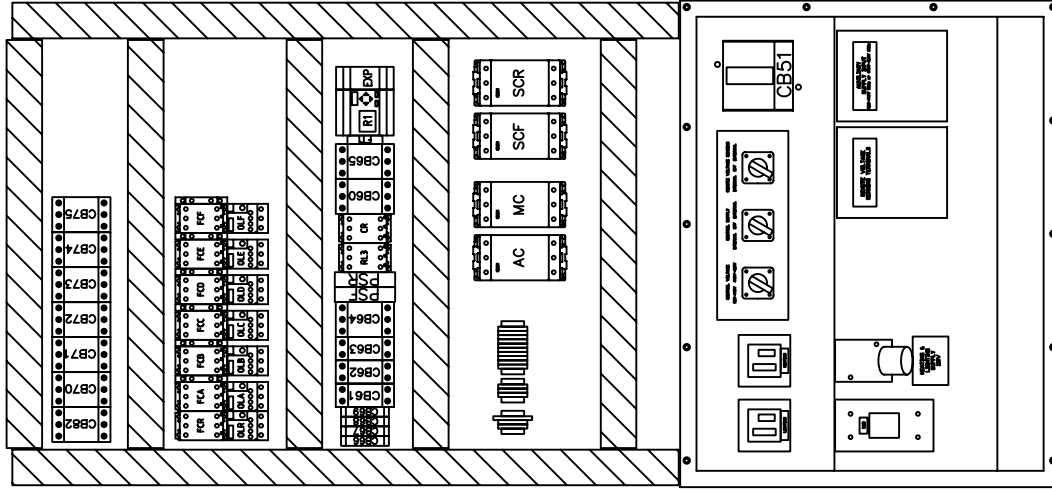

MICRO-CONTROL ENVIRONMENTAL CHAMBER

INSIDE CHAMBER

REAR OF DOOR

Crestchic Loadbanks
2nd Avenue, Centrum 100, Burton-on-Trent,
Staffordshire, DE14 2WF, United Kingdom.
TEL. +44 (0)1283 531645 FAX. +44 (0)1283 510103

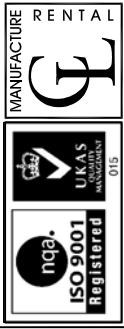

Crestchic Loadbanks
WORLDWIDE LOADBANK SPECIALISTS

CUSTOMER
CRESTCHIC
(ASIA-PACIFIC) PTE LTD

TITLE
GENERAL ARRANGEMENT 3.3MVA
480V, 60Hz, 3-PHASE, 4-WIRE
SOLAR MICRO 10FT CONT LOADBANK

DRAWN BY
Michael Pennington

CHECKED
Davy Chamberlain

CONTRACT
C3381

DATE
07/06/06

SCALE
DNS

ISSUE	DATE	CHANGE No.	DESCRIPTION
1		CL11681	
DRG. No.			SHEETNO.
CL11681			2 of 5
			A 3

A B C D E F

1 2 3 4 5 6 7 8

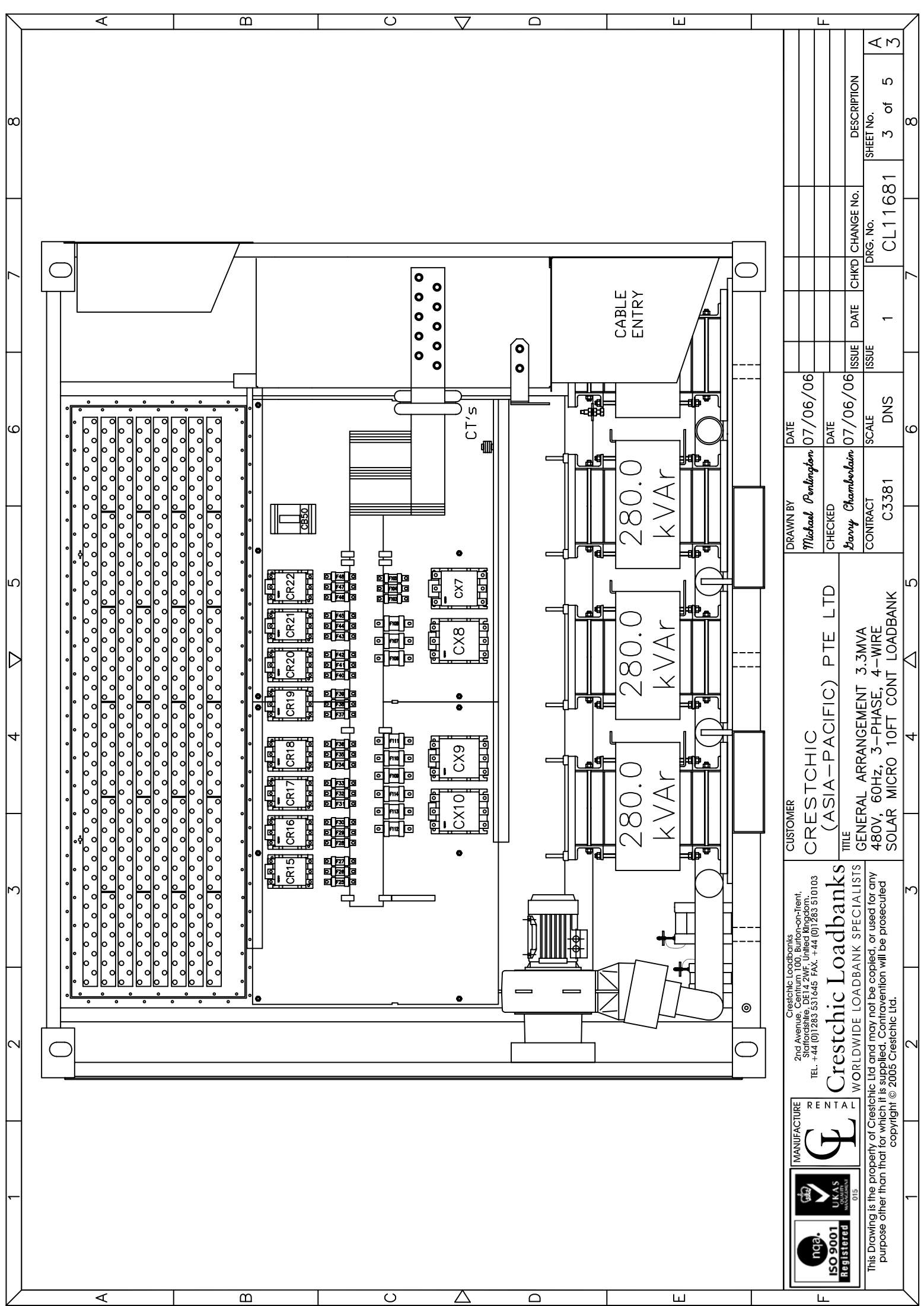

DATE	07/06/06	ISSUE	1	DRG. No.	CL11681	DESCRIPTION	A
DRAWN BY	Michael Pennington	CHECKED	Davy Chamberlain	CHANGE No.			3
DATE	07/06/06	ISSUE					5
CONTRACT	C3381	SCALE	DNS				8

CUSTOMER
CRESTCHIC
 (ASIA-PACIFIC) PTE LTD
TITLE
 GENERAL ARRANGEMENT 3.3MVA
 480V, 60Hz, 3-PHASE, 4-WIRE
 SOLAR MICRO 10FT CONT LOADBANK

Crestchic Loadbanks
 2nd Avenue, Centrum 100, Burton-on-Trent,
 Staffordshire, DE14 2WF, United Kingdom.
 TEL. +44 (0)1283 531645 FAX. +44 (0)1283 510103

Crestchic Loadbanks
 WORLDWIDE LOADBANK SPECIALISTS

MANUFACTURE PR NTAL

This Drawing is the property of Crestchic Ltd and may not be copied, or used for any purpose other than that for which it is supplied. Contravention will be prosecuted copyright © 2005 Crestchic Ltd.

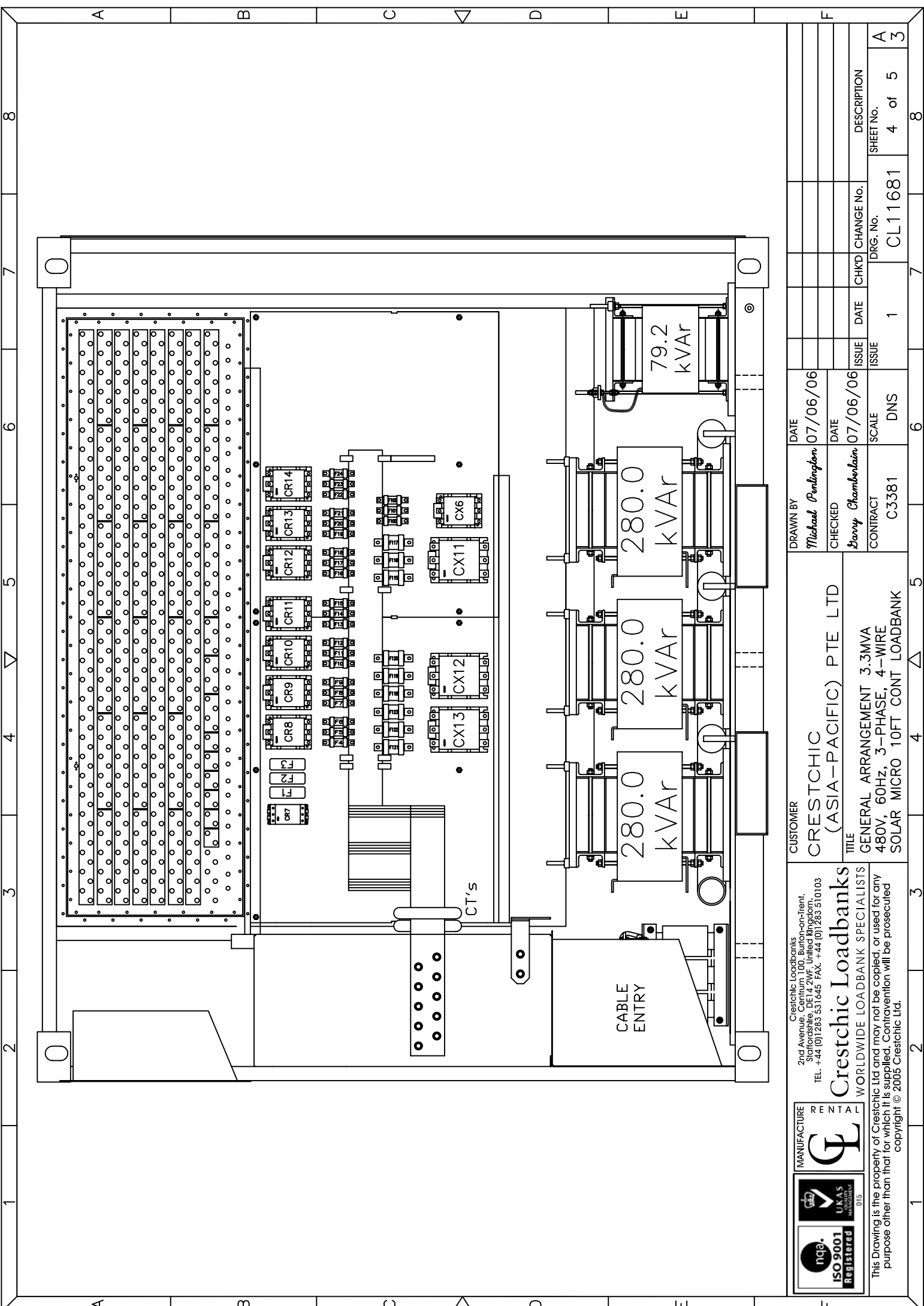

DRAWN BY <i>Michael Pennington</i>	DATE 07/06/06
CHECKED <i>Darry Chamberlain</i>	DATE 07/06/06
CONTRACT C3381	SCALE DNS
ISSUE 1	ISSUE 1
CHG'D CL11681	CHANGE No. CL11681
DRG. No.	DRG. No.
DATE	DATE
DESCRIPTION	DESCRIPTION
SHEET No. 4 of 5	SHEET No. 4 of 5

CUSTOMER
**CRESTCHIC
(ASIA-PACIFIC) PTE LTD**

TITLE
**GENERAL ARRANGEMENT 3.3MVA
480V, 60Hz, 3-PHASE, 4-WIRE
SOLAR MICRO 10FT CONT LOADBANK**

Crestchic Loadbanks
2nd Avenue, Centrum 100, Burton-on-Trent,
Staffordshire, DE14 2WF, United Kingdom.
TEL. +44 (0)1283 531645 FAX. +44 (0)1283 510103

Crestchic Loadbanks
WORLDWIDE LOADBANK SPECIALISTS

This Drawing is the property of Crestchic Ltd and may not be copied, or used for any purpose other than that for which it is supplied. Contravention will be prosecuted
copyright © 2005 Crestchic Ltd.

MANUFACTURE PR INTAL

nqa.
ISO 9001
Registered

UKAS
MANUFACTURING
015

This Drawing is the property of Crestchic Ltd and may not be copied, or used for any purpose other than that for which it is supplied. Contravention will be prosecuted
copyright © 2005 Crestchic Ltd.

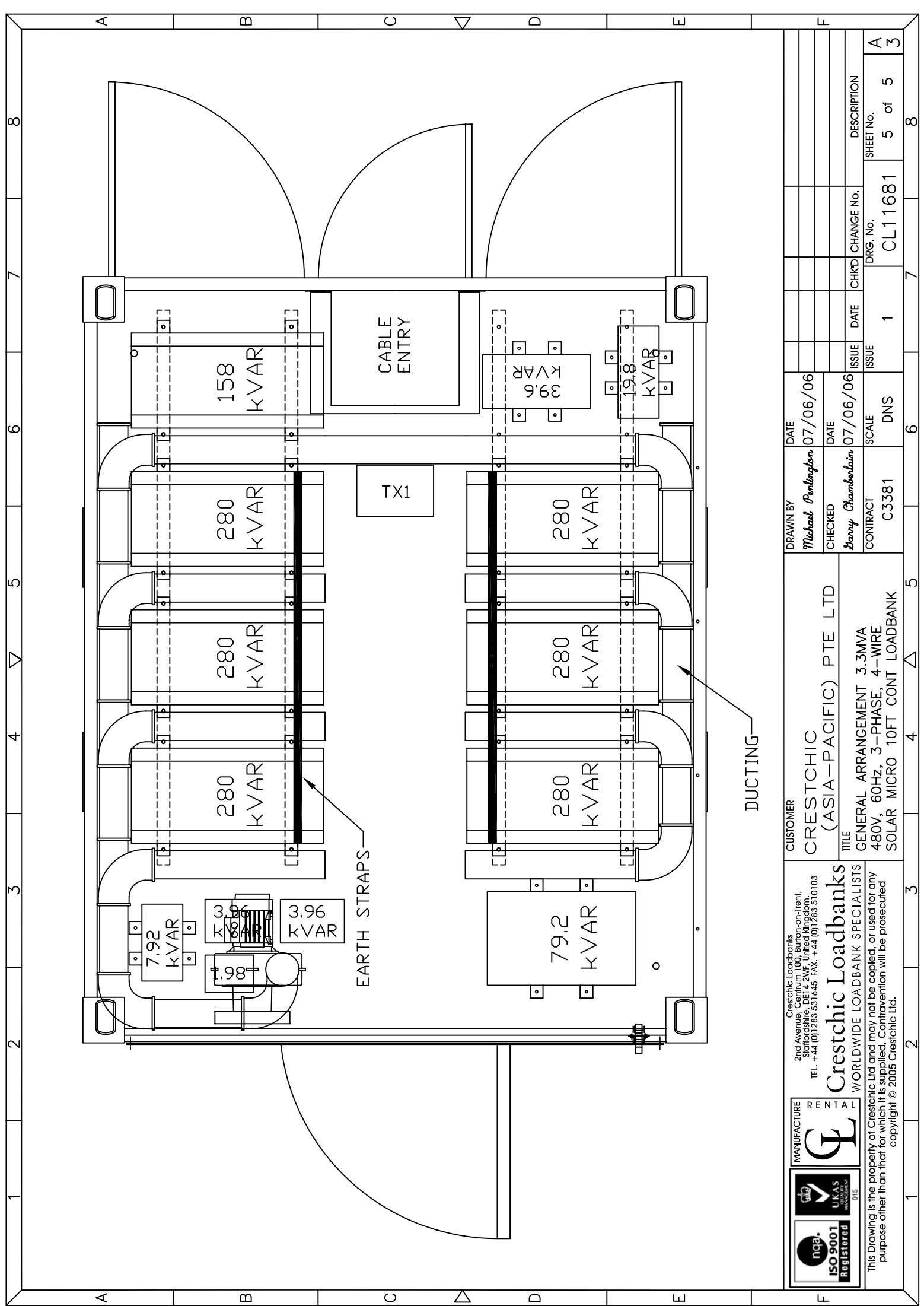

CRESTCHIC LOADBANKS 2nd Avenue, Centrum 100, Burton-on-Trent, Staffordshire, DE14 2WF, United Kingdom. TEL. +44 (0)1283 531645 FAX. +44 (0)1283 510103		CRESTCHIC LOADBANKS SPECIALISTS WORLDWIDE LOADBANK SPECIALISTS		CRESTCHIC (ASIA-PACIFIC) PTE LTD TITLE GENERAL ARRANGEMENT 3.3MVA 480V, 60Hz, 3-PHASE, 4-WIRE SOLAR MICRO 10FT CONT LOADBANK		CUSTOMER CRESTCHIC (ASIA-PACIFIC) PTE LTD		DRAWN BY <i>Michael Pennington</i>		DATE 07/06/06	
MANUFACTURE 				CHECKED <i>Davy Chamberlain</i>		DATE 07/06/06		ISSUE 1		DATE 07/06/06	
This Drawing is the property of Crestchic Ltd and may not be copied, or used for any purpose other than that for which it is supplied. Contravention will be prosecuted copyright © 2005 Crestchic Ltd.		CONTRACT C3381		SCALE DNS		ISSUE DNS		CHG'D CL11681		CHANGE No. 5 of 5	
SHEET No. 5 of 5		DESCRIPTION A		DRG. No. CL11681		ISSUE 1		DATE 07/06/06		DATE 07/06/06	



Crestchic Loadbanks
WORLDWIDE LOADBANK SPECIALISTS

12. DRAWINGS – WIRING DIAGRAMS

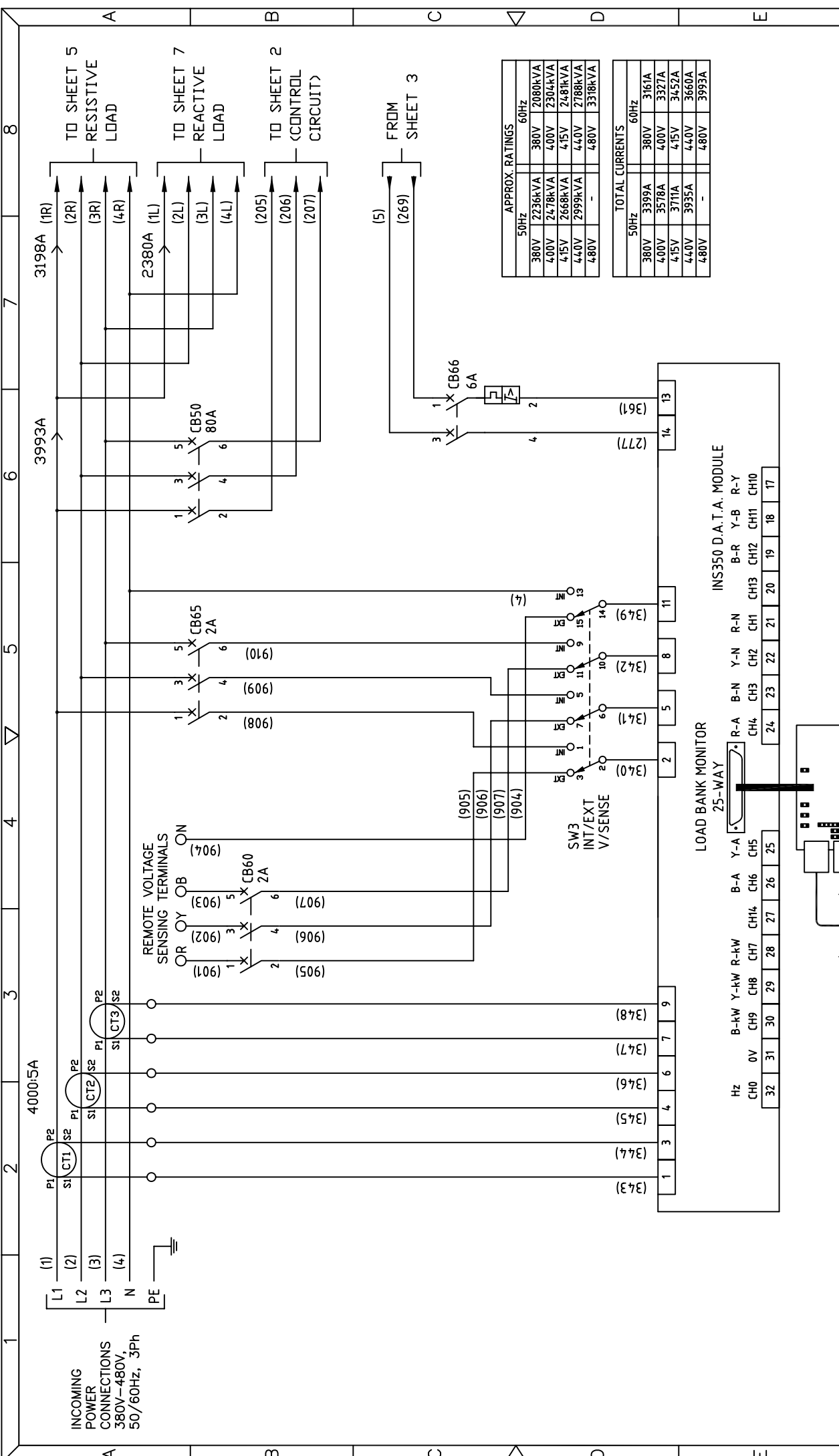

APPROX. RATINGS	
50Hz	60Hz
380V 2236kVA	380V 2080kVA
400V 2478kVA	400V 2304kVA
415V 2668kVA	415V 2481kVA
440V 2999kVA	440V 2788kVA
480V -	480V 3378kVA

TOTAL CURRENTS	
50Hz	60Hz
380V 3399A	380V 3161A
400V 3578A	400V 3327A
415V 3711A	415V 3452A
440V 3935A	440V 3660A
480V -	480V 3993A

WIRING IN-ACCORDANCE WITH CL6198 TO SHEET 11

CURRENTS SHOWN CALCULATED AT 480V 60HZ

2nd Avenue, Centrum 100, Burton-on-Trent, Staffordshire, DE14 2WF, United Kingdom. TEL. +44 (0)1283 531645 FAX. +44 (0)1283 510103		CUSTOMER CRESTCHIC (ASIA-PACIFIC) PTE LTD		DATE 07/06/06	
WORLDWIDE LOADBANK SPECIALISTS copyright © 2005 Crestchic Ltd.		TITLE WIRING DIAGRAM 3.3MVA 480V, 60HZ, 3-PHASE, 4-WIRE SOLAR MICRO 10FT CONT LOADBANK		DATE 07/06/06	
This Drawing is the property of Crestchic Ltd and may not be copied, or used for any purpose other than that for which it is supplied. Contravention will be prosecuted.		CONTRACT C3381		SCALE DNS	
MANUFACTURE		CHECKED <i>Davy Chamberlain</i>		ISSUE 1	
DRIVEN BY <i>Michael Pennington</i>		DATE 07/06/06		CHANGE No. 1	
DRG. No. CL11682		SHEET No. 1 of 12		DESCRIPTION A 3	

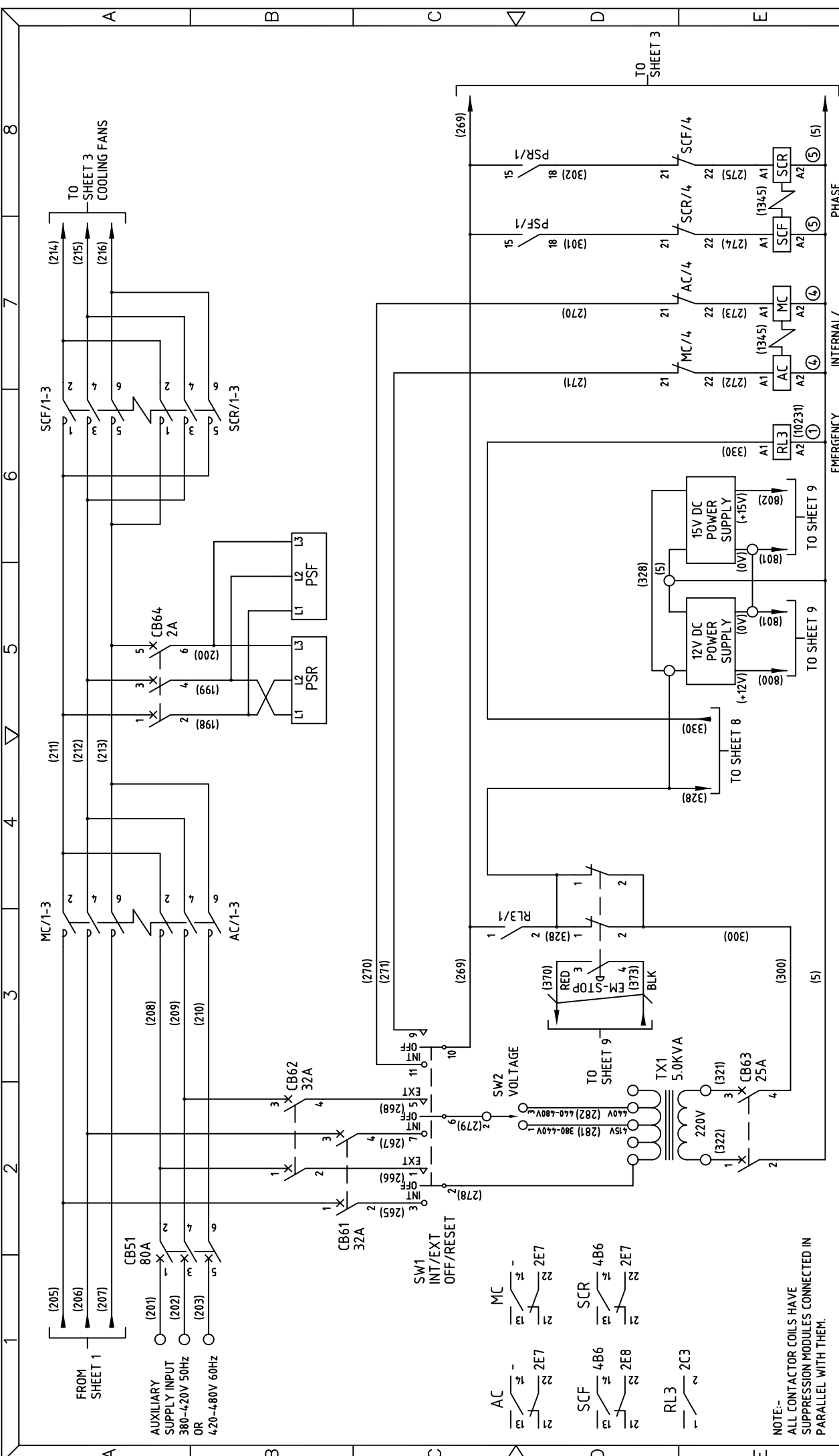

NOTE:-
ALL CONTACTOR COILS HAVE
SUPPRESSION MODULES CONNECTED IN
PARALLEL WITH THEM.

WIRING IN-ACCORDANCE WITH CL6198

			<p>Crestchic Loadbanks 2nd Avenue, Centrum 100, Burton-on-Trent, Staffordshire, DE14 2WF, United Kingdom. TEL. +44 (0)1283 531645 FAX. +44 (0)1283 510103</p>
<p>WORLDWIDE LOADBANK SPECIALISTS</p>			<p>CUSTOMER CRESTCHIC (ASIA-PACIFIC) PTE LTD</p>
<p>copyright © 2005 Crestchic Ltd.</p>			<p>TITLE WIRING DIAGRAM 3.3MVA 480V, 60Hz, 3-PHASE, 4-WIRE SOLAR MICRO 10FT CONT LOADBANK</p>

<p>DRAWN BY <i>Michael Pennington</i></p>	<p>CHECKED <i>Davy Chamberlain</i></p>	<p>DATE 07/06/06</p>	<p>DATE 07/06/06</p>
<p>CONTRACT C3381</p>	<p>SCALE DNS</p>	<p>ISSUE 1</p>	<p>ISSUE 1</p>

<p>EMERGENCY STOP RELAY</p>	<p>INTERNAL/EXTERNAL CONTACTORS</p>	<p>PHASE SEQUENCE CONTACTORS</p>
<p>RL3 (10231)</p>	<p>AC/4, MC/4, SCF/4</p>	<p>PSF/1, PSR/1, SCF/4</p>
<p>TO SHEET 9</p>	<p>TO SHEET 9</p>	<p>TO SHEET 3</p>

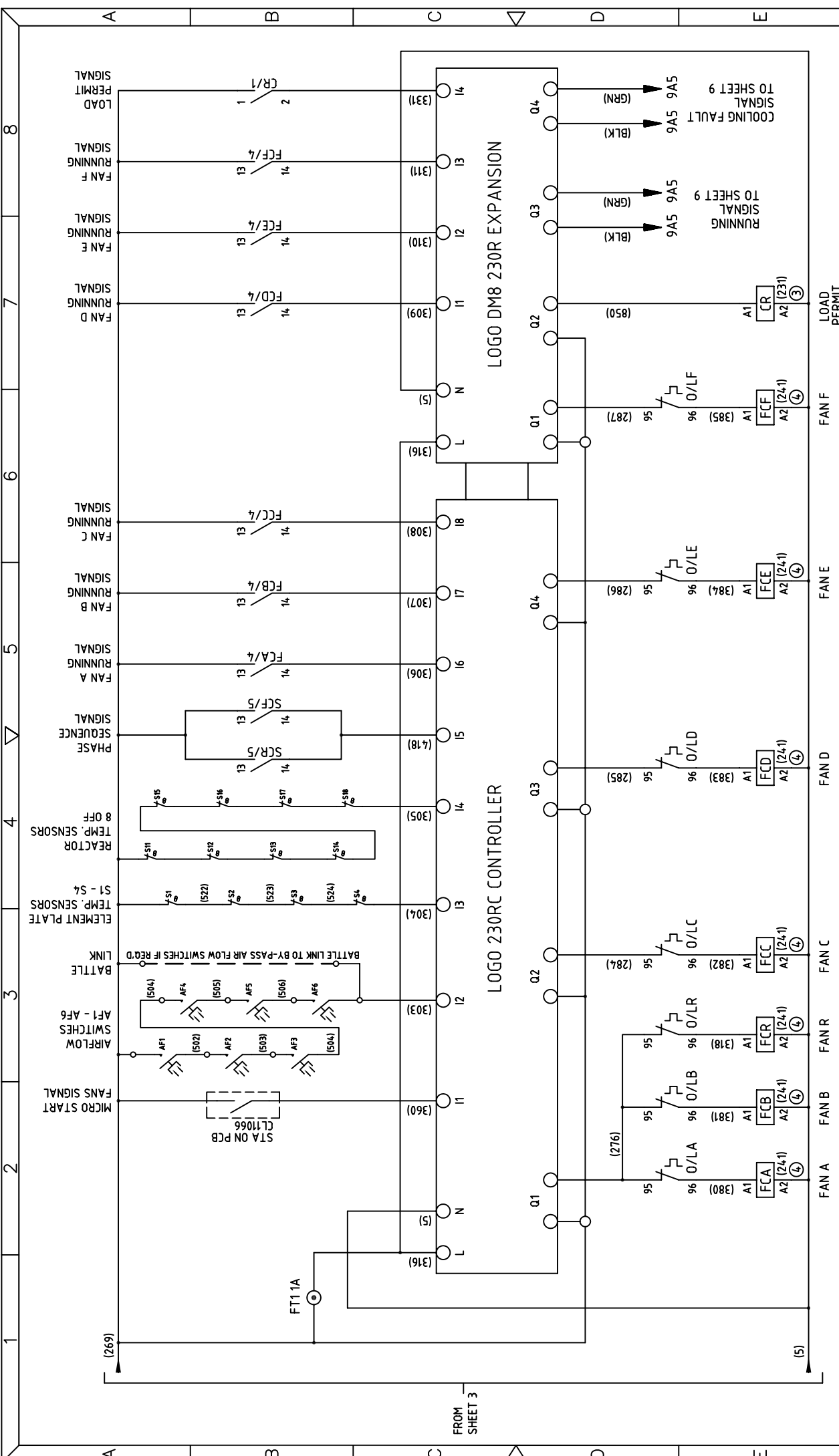

WIRING IN-ACCORDANCE WITH CL6198

NOTE:- ALL CONTACTOR COILS HAVE SUPPRESSION MODULES CONNECTED IN PARALLEL WITH THEM.

MANUFACTURE Crestchic Loadbanks WORLDWIDE LOADBANK SPECIALISTS copyright © 2005 Crestchic Ltd.		CUSTOMER CRESTCHIC (ASIA-PACIFIC) PTE LTD TITLE WIRING DIAGRAM 3.3MVA 480V, 60Hz, 3-PHASE, 4-WIRE SOLAR MICRO 10FT CONT LOADBANK		DRAWN BY <i>Michael Pennington</i> CHECKED <i>Darry Chamberlain</i> CONTRACT C3381		DATE 07/06/06 DATE 07/06/06 SCALE DNS		ISSUE 1 CHANGE No. 4 of 12 SHEET No. 4 of 12	

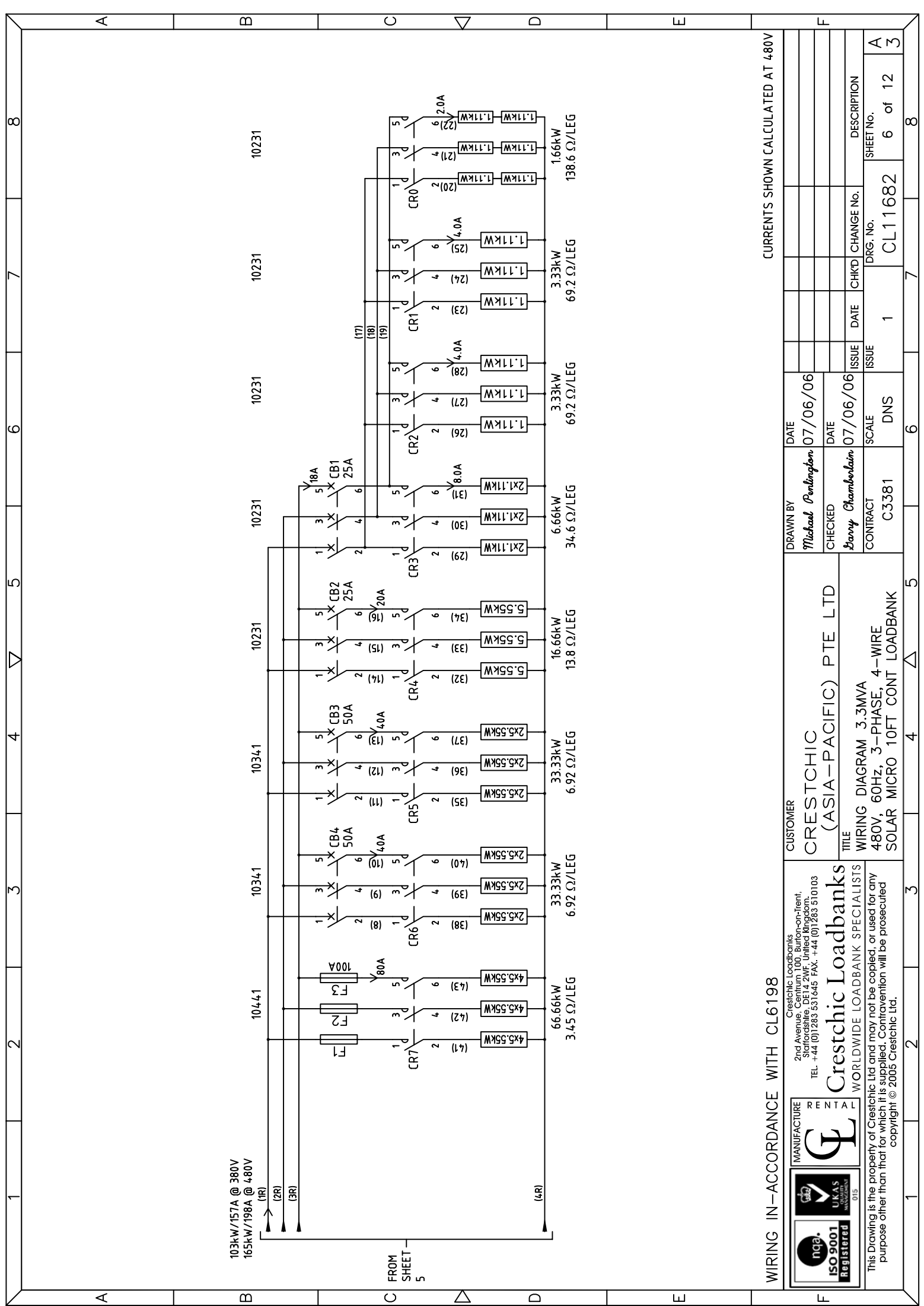

CURRENTS SHOWN CALCULATED AT 480V

WIRING IN-ACCORDANCE WITH CL6198

						<p>Crestchic Loadbanks 2nd Avenue, Centrum 100, Burton-on-Trent, Staffordshire, DE14 2WF, United Kingdom. TEL. +44 (0)1283 531645 FAX. +44 (0)1283 510103</p>		<p>CUSTOMER CRESTCHIC (ASIA-PACIFIC) PTE LTD</p>		<p>DRAWN BY <i>Michael Pennington</i></p>		<p>DATE 07/06/06</p>		<p>DRG. No. CL11682</p>	
<p>WORLDWIDE LOADBANK SPECIALISTS</p>		<p>WIRING DIAGRAM 3.3MVA 480V, 60Hz, 3-PHASE, 4-WIRE SOLAR MICRO 10FT CONT LOADBANK</p>		<p>TITLE</p>		<p>CHECKED <i>Darry Chamberlain</i></p>		<p>DATE 07/06/06</p>		<p>ISSUE 1</p>		<p>CHANGE No.</p>		<p>DESCRIPTION</p>	
<p>This Drawing is the property of Crestchic Ltd and may not be copied, or used for any purpose other than that for which it is supplied. Contravention will be prosecuted copyright © 2005 Crestchic Ltd.</p>		<p>SCALE DNS</p>		<p>CONTRACT C3381</p>		<p>ISSUE 6</p>		<p>SCALE DNS</p>		<p>ISSUE 1</p>		<p>CHANGE No. CL11682</p>		<p>DESCRIPTION SHEET NO. 6 of 12</p>	
<p>1</p>		<p>2</p>		<p>3</p>		<p>4</p>		<p>5</p>		<p>6</p>		<p>7</p>		<p>8</p>	

220V A.C.
FROM SHEET 3

REFER TO SHEET 9

220V A.C.
FROM SHEET 3

REACTIVE

RESISTIVE

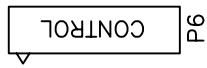
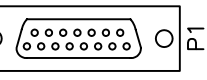
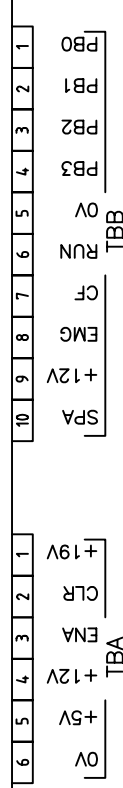
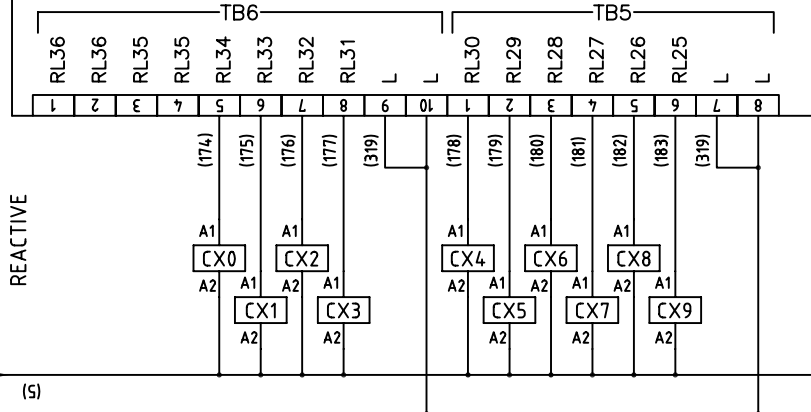

SOLAR DRIVER BOARD
PCB CL11066

REACTIVE
P4

RESISTIVE
P3

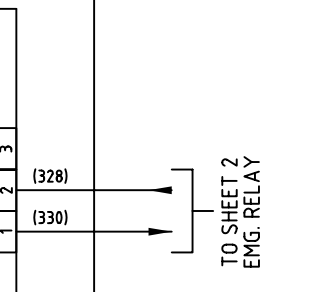
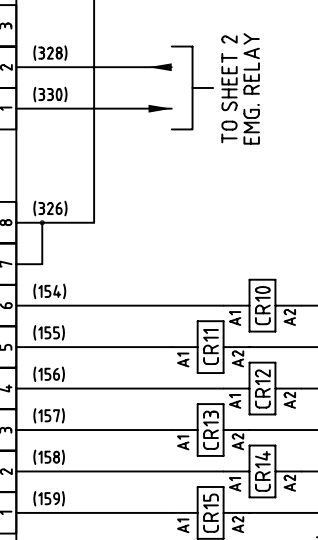
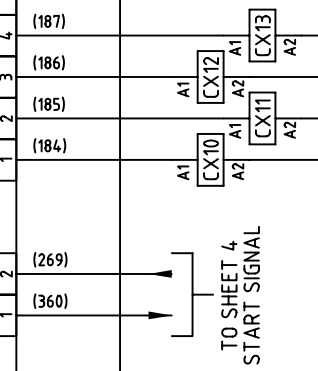
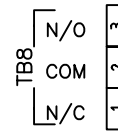
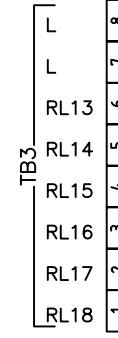
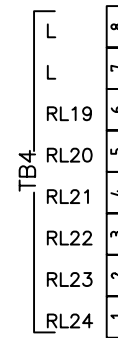
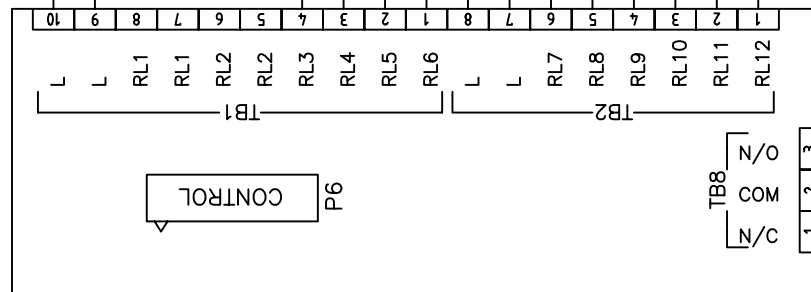

NOTE:- ALL CONTACTOR
COILS HAVE SUPPRESSION
MODULES CONNECTED
IN PARALLEL WITH THEM.

TO SHEET 4
START SIGNAL

TO SHEET 2
EMG. RELAY

WIRING IN-ACCORDANCE WITH CL6198

Crestchic Loadbanks
 2nd Avenue, Centrum 100, Burton-on-Trent,
 Staffordshire, DE14 2WF, United Kingdom.
 TEL. +44 (0)1283 531645 FAX. +44 (0)1283 510103

WORLDWIDE LOADBANK SPECIALISTS
 copyright © 2005 Crestchic Ltd.

CUSTOMER
CRESTCHIC
 (ASIA-PACIFIC) PTE LTD

TITLE
 WIRING DIAGRAM 3.3MVA
 480V, 60Hz, 3-PHASE, 4-WIRE
 SOLAR MICRO 10FT CONT LOADBANK

DRAWN BY <i>Michael Pennington</i>	DATE 07/06/06
CHECKED <i>Darry Chamberlain</i>	DATE 07/06/06
CONTRACT C3381	SCALE DNS
ISSUE 1	ISSUE 1
CHANGE No.	DATE
CHK'D	DATE

DRG. No.	CL11682
SHEET No.	8 of 12
DESCRIPTION	A

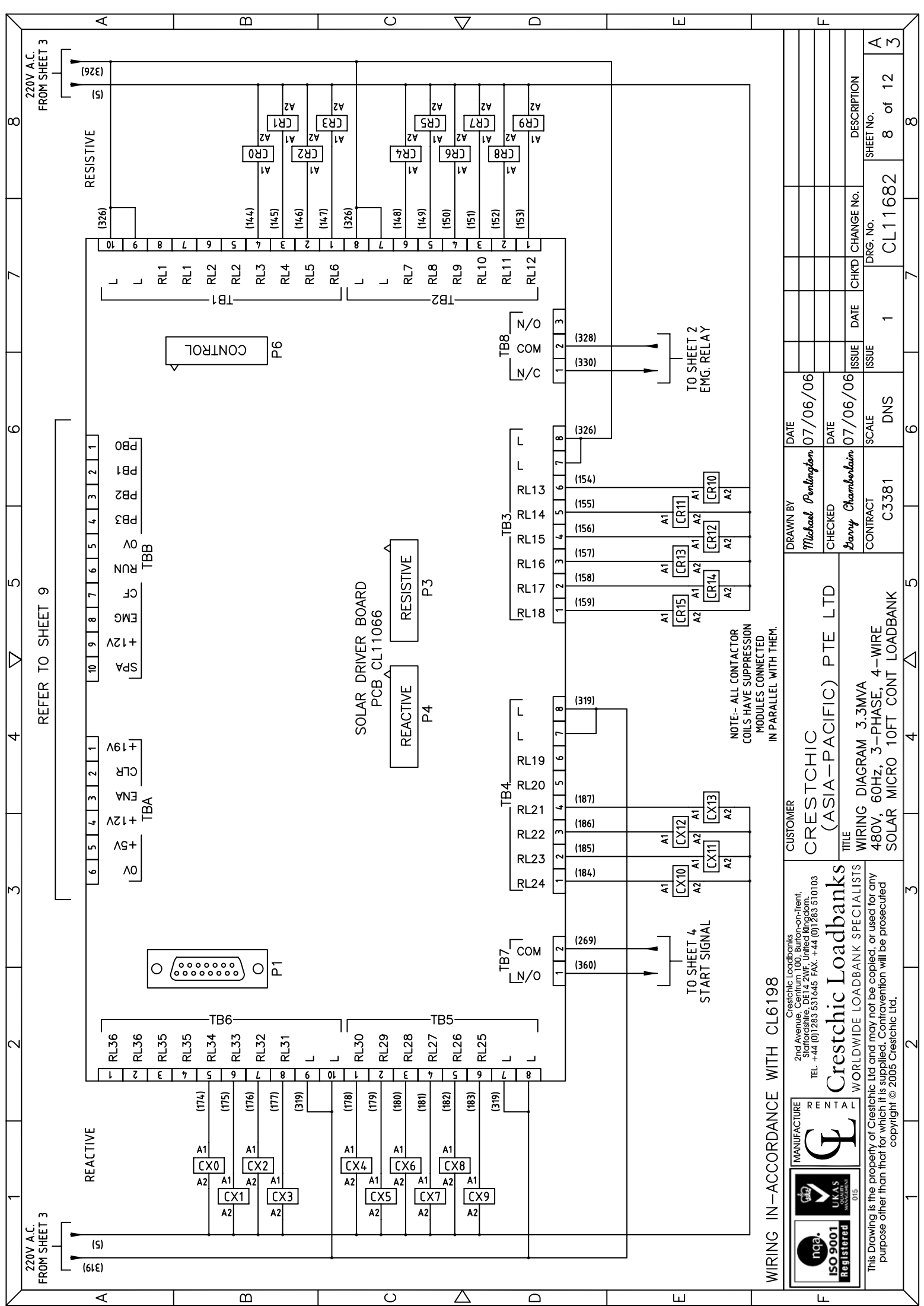

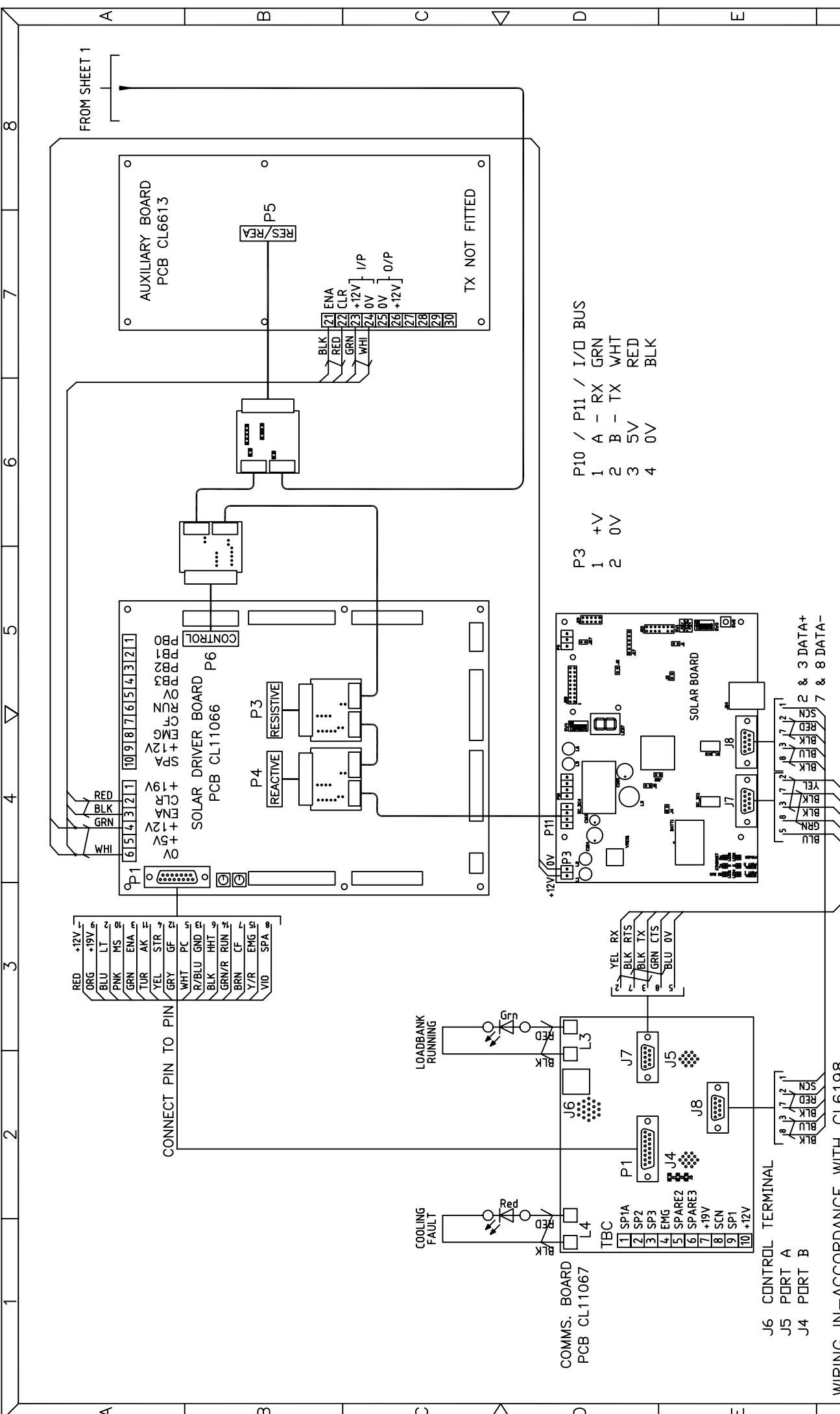

DRAWN BY <i>Michael Pennington</i>		DATE 07/06/06	CUSTOMER CRESTCHIC (ASIA-PACIFIC) PTE LTD	
CHECKED <i>Davy Chamberlain</i>		DATE 07/06/06	TITLE WIRING DIAGRAM 3.3MVA 480V, 60Hz, 3-PHASE, 4-WIRE SOLAR MICRO 10FT CONT LOADBANK	
CONTRACT C3381		SCALE DNS	CONTRACT	
ISSUE 1		ISSUE 1	ISSUE	
CHANGE No.		DATE	DESCRIPTION	
DRG. No. CL11682		11 of 12		SHEET No. 3

WIRING IN-ACCORDANCE WITH CL6198

CRESTCHIC LOADBANKS
WORLDWIDE LOADBANK SPECIALISTS

MANUFACTURE
nqa. ISO 9001 Registered



UKAS
5110103

CRESTCHIC LOADBANKS
2nd Avenue, Centrum 100, Burton-on-Trent,
Staffordshire, DE14 2WF, United Kingdom.
TEL. +44 (0)1283 531645 FAX. +44 (0)1283 510103

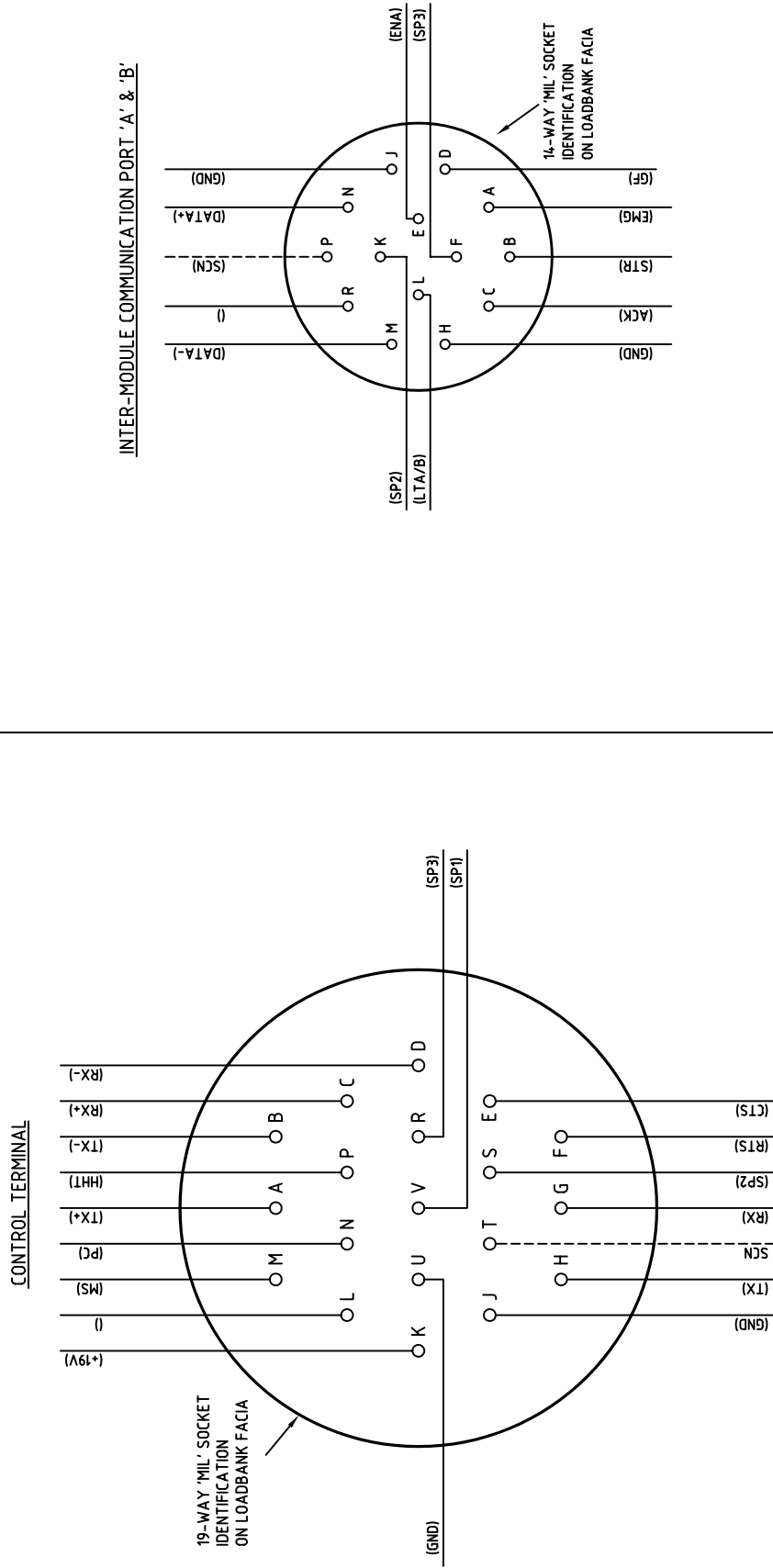
This Drawing is the property of Crestchic Ltd and may not be copied, or used for any purpose other than that for which it is supplied. Contravention will be prosecuted
copyright © 2005 Crestchic Ltd.



WIRING IN-ACCORDANCE WITH CL6198

Crestchic Loadbanks
 2nd Avenue, Centrum 100, Burton-on-Trent,
 Staffordshire, DE14 2WF, United Kingdom.
 TEL. +44 (0)1283 531645 FAX. +44 (0)1283 510103

WORLDWIDE LOADBANK SPECIALISTS
 This Drawing is the property of Crestchic Ltd and may not be copied, or used for any purpose other than that for which it is supplied. Contravention will be prosecuted copyright © 2005 Crestchic Ltd.

CUSTOMER
CRESTCHIC
 (ASIA-PACIFIC) PTE LTD
 TITLE
 WIRING DIAGRAM 3.3MVA
 480V, 60Hz, 3-PHASE, 4-WIRE
 SOLAR MICRO 10FT CONT LOADBANK

DRAWN BY
Michael Pennington
 CHECKED
Davy Chamberlain
 CONTRACT
 C3381

DATE
 07/06/06
 DATE
 07/06/06
 SCALE
 DNS

ISSUE	CHANGE No.	DESCRIPTION
1	CL11682	12 of 12
DRG. No.		SHEETNO.
CL11682		12 of 12
ISSUE		A
1		3

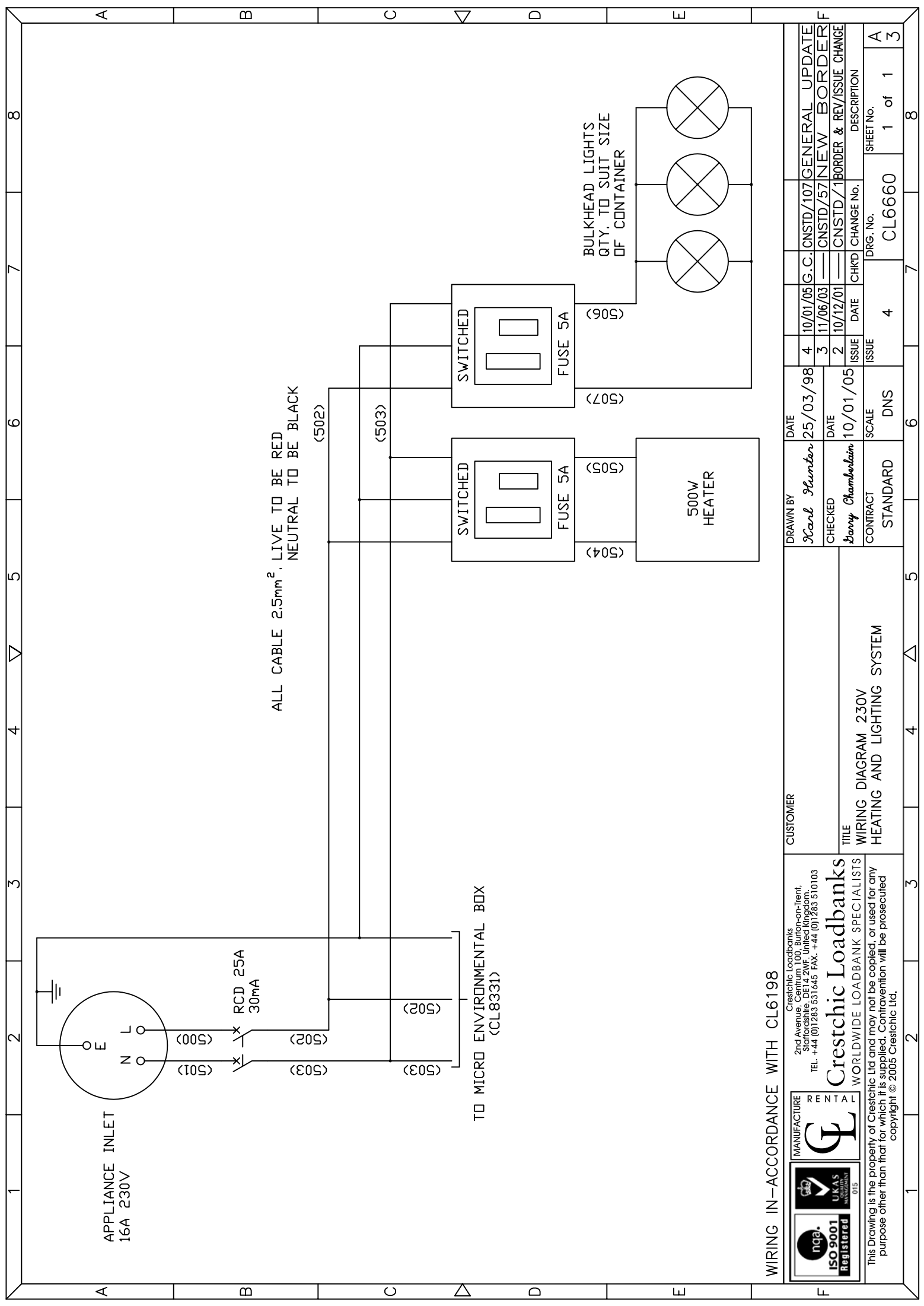

WIRING IN—ACCORDANCE WITH CL6198

			Crestchic Loadbanks WORLDWIDE LOADBANK SPECIALISTS
<small>Crestchic Loadbanks 2nd Avenue, Centrum 100, Burton-on-Trent, Staffordshire, DE14 2WF, United Kingdom. TEL. +44 (0)1283 531645 FAX. +44 (0)1283 510103</small>			
<small>This Drawing is the property of Crestchic Ltd and may not be copied, or used for any purpose other than that for which it is supplied. Contravention will be prosecuted copyright © 2005 Crestchic Ltd.</small>			

DRAWN BY <i>Carol Hunter</i>		DATE 25/03/98
CHECKED <i>Harry Chamberlain</i>		DATE 10/01/05
CONTRACT STANDARD	SCALE DNS	ISSUE 4
TITLE WIRING DIAGRAM 230V HEATING AND LIGHTING SYSTEM		CUSTOMER

4	10/01/05	G.C.	CNSTD/107	GENERAL UPDATE
3	11/06/03		CNSTD/57	NEW BORDER
2	10/12/01		CNSTD/1	BORDER & REV/ISSUE CHANGE
ISSUE	DATE	CHKD	CHANGE No.	DESCRIPTION
DRG. No.		CL6660		SHEET No.
1 of 1		4		3

A B C D E F



1 2 3 4 5 6 7 8

A B C D E F

WIRE NUMBER	WIRE DETAILS	PCB TERMINAL	OUTPUT REF.	PCB IDENT.
		PIN NUMBER	BIT	
326	1.00mm ² BRN	TB1 - 10	TB1 COIL FEED	CL11066
326	1.00mm ² BRN	TB1 - 9	TB1 COIL FEED	CL11066
140	0.75mm ² BRN	TB1 - 8	RL1	CL11066
141	0.75mm ² BRN	TB1 - 7	RL1	CL11066
142	0.75mm ² BRN	TB1 - 6	RL2	CL11066
143	0.75mm ² BRN	TB1 - 5	RL2	CL11066
144	0.75mm ² BRN	TB1 - 4	RL3 0	CL11066
145	0.75mm ² BRN	TB1 - 3	RL4 1	CL11066
146	0.75mm ² BRN	TB1 - 2	RL5 2	CL11066
147	0.75mm ² BRN	TB1 - 1	RL6 3	CL11066
326	1.00mm ² BRN	TB2 - 8	TB2 COIL FEED	CL11066
326	1.00mm ² BRN	TB2 - 7	TB2 COIL FEED	CL11066
148	0.75mm ² BRN	TB2 - 6	RL7 4	CL11066
149	0.75mm ² BRN	TB2 - 5	RL8 5	CL11066
150	0.75mm ² BRN	TB2 - 4	RL9 6	CL11066
151	0.75mm ² BRN	TB2 - 3	RL10 7	CL11066
152	0.75mm ² BRN	TB2 - 2	RL11 8	CL11066
153	0.75mm ² BRN	TB2 - 1	RL12 9	CL11066
326	1.00mm ² BRN	TB3 - 8	TB3 COIL FEED	CL11066
326	1.00mm ² BRN	TB3 - 7	TB3 COIL FEED	CL11066
154	0.75mm ² BRN	TB3 - 6	RL13 10	CL11066
155	0.75mm ² BRN	TB3 - 5	RL14 11	CL11066
156	0.75mm ² BRN	TB3 - 4	RL15 12	CL11066
157	0.75mm ² BRN	TB3 - 3	RL16 13	CL11066
158	0.75mm ² BRN	TB3 - 2	RL17 14	CL11066
159	0.75mm ² BRN	TB3 - 1	RL18 15	CL11066

CL11066 32-BIT MICRO
CL6613 16-BIT EXPANDER (IF FITTED)

WIRE NUMBER	WIRE DETAILS	PCB TERMINAL	OUTPUT REF.	PCB IDENT.
		PIN NUMBER	BIT	
360	0.75mm ² BRN	TB7 - 1	STA NO	CL11066
269	0.75mm ² BRN	TB7 - 2	STA C	CL11066
330	0.75mm ² BRN	TB8 - 1	EMG/1 NC	CL11066
328	0.75mm ² BRN	TB8 - 2	EMG/1 C	CL11066
		TBB - 1	PB0	CL11066
		TBB - 2	PB1	CL11066
		TBB - 3	PB2	CL11066
		TBB - 4	PB3	CL11066
		TBB - 5	0V	CL11066
		TBB - 6	RUN	CL11066
		TBB - 7	CF	CL11066
		TBB - 8	EMG	CL11066
		TBB - 9	+12V	CL11066
		TBB - 10	SPA	CL11066
		TBA - 1	+19V	CL11066
		TBA - 2	CLR	CL11066
		TBA - 3	ENA	CL11066
		TBA - 4	+12V	CL11066
		TBA - 5	+5V	CL11066
		TBA - 6	0V	CL11066
		1	RS COIL FEED	CL6613
		7	PA0 16	CL6613
		6	PA1 17	CL6613
		8	PA2 18	CL6613
		5	PA3 19	CL6613
		9	PA4 20	CL6613
		4	PA5 21	CL6613
		10	PA6 22	CL6613
		3	PA7 23	CL6613

Crestchic Loadbanks
 2nd Avenue, Centrum 100, Burton-on-Trent,
 Staffordshire, DE14 2WF, United Kingdom.
 TEL: +44 (0)1283 531645 FAX: +44 (0)1283 510103

Crestchic Loadbanks
 WORLDWIDE LOADBANK SPECIALISTS

This Drawing is the property of Crestchic Ltd and may not be copied, or used for any purpose other than that for which it is supplied. Contravention will be prosecuted.
 copyright © 2005 Crestchic Ltd.

CUSTOMER
 CONTAINER COMPUTER CONNECTION
 TITLE
 DETAILS (RS)
 (32 + 16 BIT MICRO)

DRAWN BY
Savvy Chamberlain
 DATE
 12/07/05

CHECKED
Michael Pennington
 DATE
 12/07/05

CONTRACT
 STANDARD
 SCALE
 DNS

ISSUE
 1

CHANGE No.
 CL11174

DRG. No.
 1 of 3

DESCRIPTION
 SHEET No.
 3

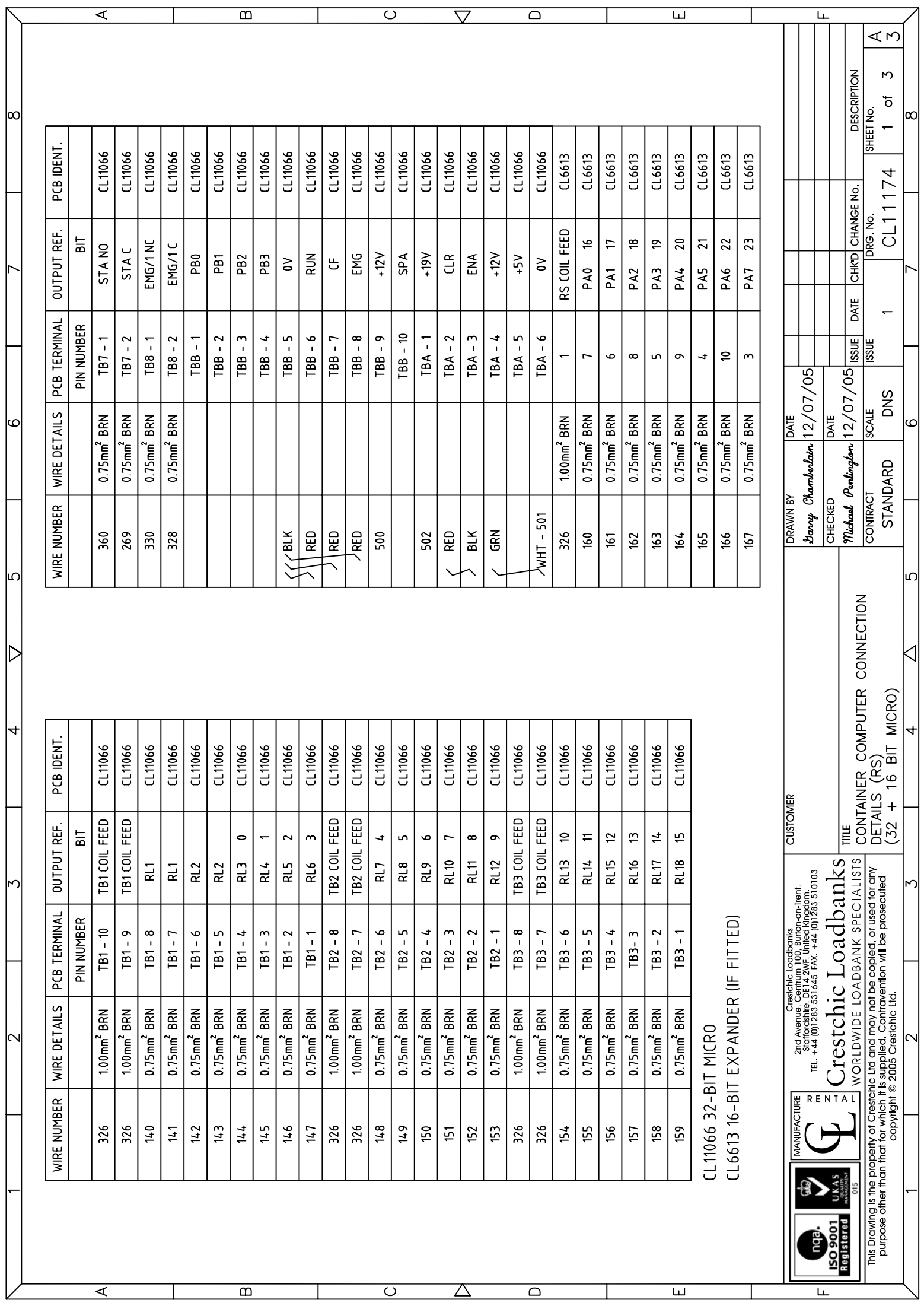

WIRE NUMBER	WIRE DETAILS	PCB TERMINAL	OUTPUT REF.	PCB IDENT.
170	0.75mm ² BRN	TB6 - 1	RL36	CL11066
171	0.75mm ² BRN	TB6 - 2	RL36	CL11066
172	0.75mm ² BRN	TB6 - 3	RL35	CL11066
173	0.75mm ² BRN	TB6 - 4	RL35	CL11066
174	0.75mm ² BRN	TB6 - 5	RL34 0	CL11066
175	0.75mm ² BRN	TB6 - 6	RL33 1	CL11066
176	0.75mm ² BRN	TB6 - 7	RL32 2	CL11066
177	0.75mm ² BRN	TB6 - 8	RL31 3	CL11066
319	1.00mm ² BRN	TB6 - 9	TB6 COIL FEED	CL11066
319	1.00mm ² BRN	TB6 - 10	TB6 COIL FEED	CL11066
178	0.75mm ² BRN	TB5 - 1	RL30 4	CL11066
179	0.75mm ² BRN	TB5 - 2	RL29 5	CL11066
180	0.75mm ² BRN	TB5 - 3	RL28 6	CL11066
181	0.75mm ² BRN	TB5 - 4	RL27 7	CL11066
182	0.75mm ² BRN	TB5 - 5	RL26 8	CL11066
183	0.75mm ² BRN	TB5 - 6	RL25 9	CL11066
319	1.00mm ² BRN	TB5 - 7	TB5 COIL FEED	CL11066
319	1.00mm ² BRN	TB5 - 8	TB5 COIL FEED	CL11066
184	0.75mm ² BRN	TB4 - 1	RL24 10	CL11066
185	0.75mm ² BRN	TB4 - 2	RL23 11	CL11066
186	0.75mm ² BRN	TB4 - 3	RL22 12	CL11066
187	0.75mm ² BRN	TB4 - 4	RL21 13	CL11066
188	0.75mm ² BRN	TB4 - 5	RL20 14	CL11066
189	0.75mm ² BRN	TB4 - 6	RL19 15	CL11066
319	1.00mm ² BRN	TB4 - 7	TB4 COIL FEED	CL11066
319	1.00mm ² BRN	TB4 - 8	TB4 COIL FEED	CL11066

CL11066 32-BIT MICRO

CL6613 16-BIT EXPANDER (IF FITTED)

WIRE NUMBER	WIRE DETAILS	PCB TERMINAL	OUTPUT REF.	PCB IDENT.
326	1.00mm ² BRN	20	RS COIL FEED	CL6613
190	0.75mm ² BRN	11	PB0 16	CL6613
191	0.75mm ² BRN	18	PB1 17	CL6613
192	0.75mm ² BRN	12	PB2 18	CL6613
193	0.75mm ² BRN	17	PB3 19	CL6613
194	0.75mm ² BRN	13	PB4 20	CL6613
195	0.75mm ² BRN	16	PB5 21	CL6613
196	0.75mm ² BRN	14	PB6 22	CL6613
197	0.75mm ² BRN	15	PB7 23	CL6613
BLK		21	ENA	CL6613
RED		22	CLR	CL6613
GRN		23	+12V	CL6613
WHI		24	0V	CL6613
BLK		25	0V	CL6613
RED		26	+12V	CL6613
5	0.75mm ² BLU	27	N FEED	CL6613
N/C	N/C	28	N/C	CL6613
N/C	N/C	29	N/C	CL6613
328	0.75mm ² BRN	30	L FEED	CL6613
328	0.75mm ² BRN	N/C	L FEED	ENVIRON
5	0.75mm ² BLU	N/C	N FEED	ENVIRON





Crestchic Loadbanks
 2nd Avenue, Centrium 100, Burton-on-Trent,
 Staffordshire, DE14 2WF, United Kingdom.
 TEL: +44 (0)1283 531645 FAX: +44 (0)1283 510103

Crestchic Loadbanks
 WORLDWIDE LOADBANK SPECIALISTS

This Drawing is the property of Crestchic Ltd and may not be copied, or used for any purpose other than that for which it is supplied. Contravention will be prosecuted copyright © 2005 Crestchic Ltd.

CUSTOMER
CONTAINER COMPUTER CONNECTION
DETAILS (XL)
(32 + 16 BIT MICRO)

TITLE

DRAWN BY
Savvy Chamberlain

CHECKED
Michael Pennington

CONTRACT
STANDARD

DATE
12/07/05

DATE
12/07/05

SCALE
DNS

ISSUE
1

CHANGE No.
CL11174

DRG. No.
CL11174

DESCRIPTION
SHEET No.
2 of 3



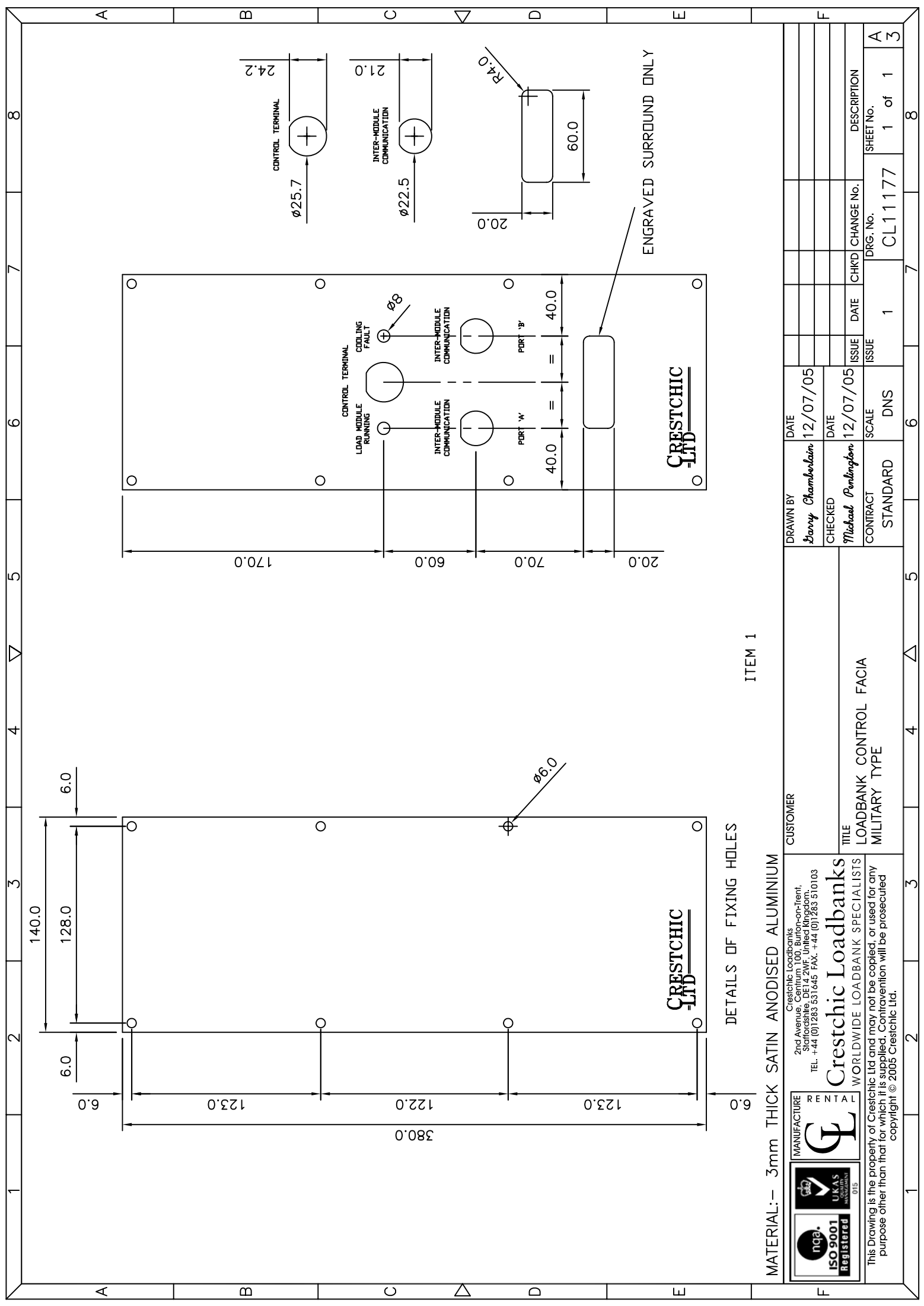

Crestchic Loadbanks
WORLDWIDE LOADBANK SPECIALISTS

13. PARTS LISTS/DRAWINGS – SUB-ASSEMBLIES



MATERIAL: - 3mm THICK SATIN ANODISED ALUMINIUM

Crestchic Loadbanks
 2nd Avenue, Centrum 100, Burton-on-Trent,
 Staffordshire, DE14 2WF, United Kingdom.
 TEL. +44 (0)1283 531645 FAX. +44 (0)1283 510103

Crestchic Loadbanks
 WORLDWIDE LOADBANK SPECIALISTS

This Drawing is the property of Crestchic Ltd and may not be copied, or used for any purpose other than that for which it is supplied. Contravention will be prosecuted copyright © 2005 Crestchic Ltd.

DRAWN BY <i>Savvy Chamberlain</i>		DATE 12/07/05
CHECKED <i>Michael Pennington</i>	DATE 12/07/05	
CONTRACT STANDARD	SCALE DNS	ISSUE 1
CUSTOMER LOADBANK CONTROL FACIA MILITARY TYPE		CHANGE No. CL11177
TITLE		DRG. No.

DETAILS OF FIXING HOLES

ITEM 1

ISSUE	DATE	CHKD	CHANGE No.	DESCRIPTION
1				
DRG. No.				SHEET No.
CL11177				1 of 1
				A
				3

ENGRAVED SURROUND ONLY

CRESTCHIC
AND
LTD

CRESTCHIC
AND
LTD

ENVIRONMENTAL CHAMBER AIR-CON. PL1229

ITEM	CIRCUIT REF	STOCK	DESCRIPTION	MANUFACTURERS REF	No.	ORDER No.
1						
2	CL8331		WIRING DIAGRAM	CL8331 ISSUE 4	REF	
3						
4						
5						
6						
7						
8		CAB391	CABLE 3-CORE ROUND, BLACK	RS 377-940	10m	
9						
10		FAN406	FAN 240V 80mm x 80mm	FEC 926-012	1	
11						
12		FAN410	FAN FILTER	FEC 147-463	1	
13						
14		FAN417	FINGER GUARD	FEC 735-978	1	
15						
16		FAN423	HEATER 10W, 240V	RS 159-2055	1	
17						
18		SEN141	THERMOSTAT	RS 298-8659	1	
19						
20	RT	RLY220	RELAY 5A 4-POLE C/O	RS 385-957	1	
21						
22		RLY221	RELAY BASE 4-POLE	RS 403-263	1	
23						
24						
25						
26						
27						
28						
29						
30						
31						
32						
33						
34						
35						
36						
37						
38						
39						
40						
41						
42						
43						
44						
45						
46						
47						
48						
49						
50						
	FORM	CF012		CRESTCHIC LIMITED		
	ISSUE	07		2ND AVENUE, CENTRUM 100,		
	ISSUE DATE	24/11/98		BURTON ON TRENT, STAFFS		
	AUTHORISED	M.W.B.		UNITED KINGDOM DE14 2WF		
				PHONE 00 44 (0)1283 531645		
				FAX 00 44 (0)1283 510103		

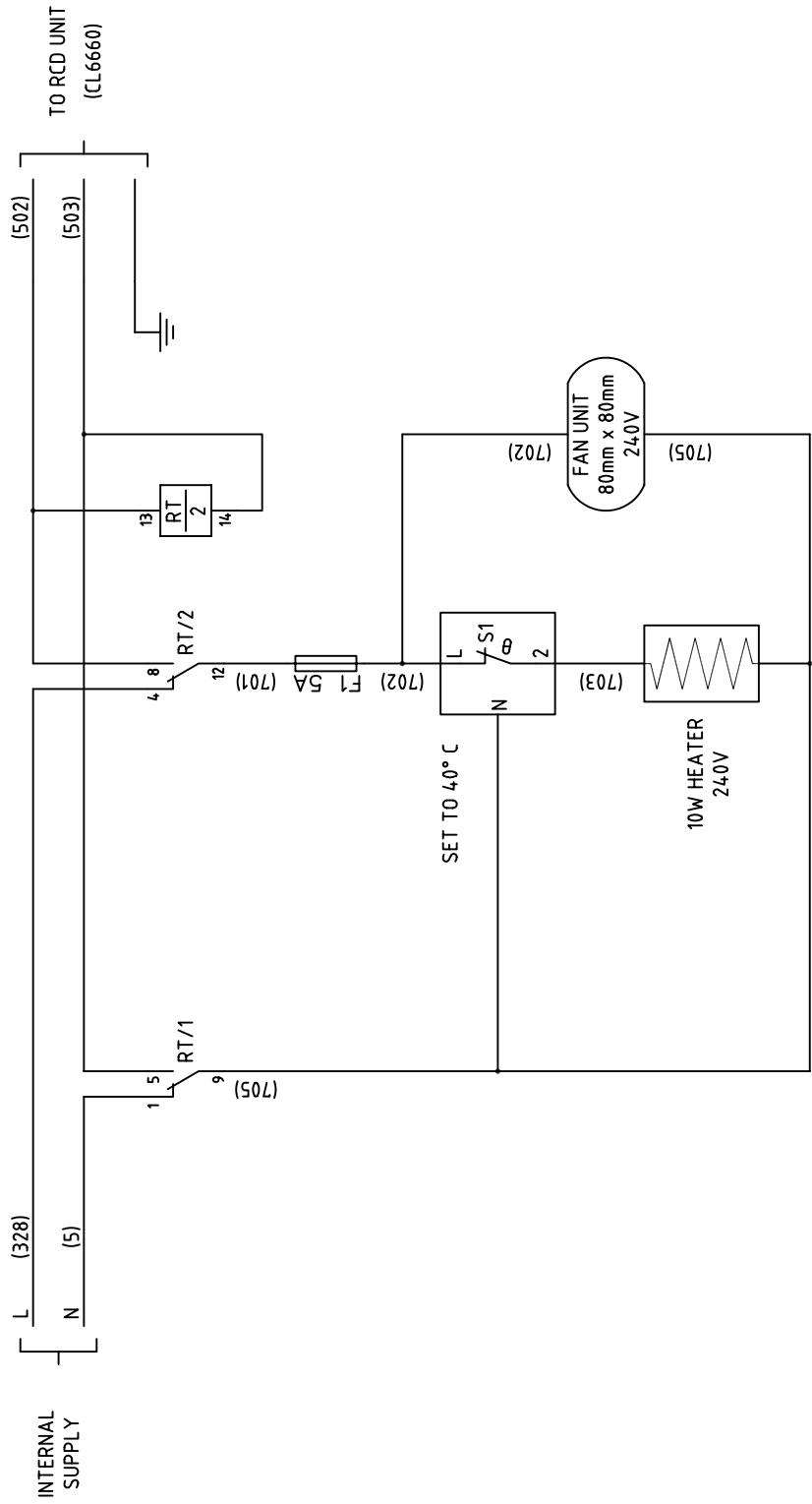

WIRING IN-ACCORDANCE WITH CL6198

MANUFACTURE

CRESTCHIC LOADBANKS

2nd Avenue, Centrum 100, Burton-on-Trent, Staffordshire, DE14 2WF, United Kingdom.
TEL. +44 (0)1283 531645 FAX. +44 (0)1283 510103

WORLDWIDE LOADBANK SPECIALISTS

ISO 9001 Registered

UKAS MANUFACTURING 015

This Drawing is the property of Crestchic Ltd and may not be copied, or used for any purpose other than that for which it is supplied. Contravention will be prosecuted
copyright © 2005 Crestchic Ltd.

DRAWN BY <i>Dave Pennell</i>		DATE 11/10/99
CHECKED <i>Harry Chamberlain</i>		DATE 10/01/05
CONTRACT STANDARD		SCALE DNS

CUSTOMER	DRG. No. CL8331
TITLE WIRING DIAGRAM 230V ENVIRONMENTAL CHAMBER AIR-CONDITIONING PL1229	ISSUE 4

4	10/01/05	G.C.	CNSTD/107	GENERAL UPDATE
3	11/06/03		CNSTD/57	NEW BORDER
2	10/12/01		CNSTD/1	BORDER & REV/ISSUE CHANGE
ISSUE	DATE	CHKD	CHANGE No.	DESCRIPTION
ISSUE	DATE	4	CL8331	SHEET No. 1 of 1
				8

10ft UL REACTOR COOLING PL1287

ITEM	CIRCUIT REF	STOCK	DESCRIPTION	MANUFACTURERS REF	No.	ORDER No.
1						
2	CL8462 ITEM 2	ENC027	FAN BRACKET	CL8462 ITEM 2 ISSUE 3	1	
3						
4	CL8462 ITEM 1	ENC024	AIRBOX DUCT	CL8462 ITEM 1 ISSUE 3	1	
5						
6		FAN380	CENTRIFUGAL FAN 50/60Hz LEFT	VBW7-LEFT-HAND VBW7-34056-11010-ID	1	
7						
8						
9						
10		WAC410	4" TEE	4P08C	5	
11						
12		WAC411	4" 90 DEGREE ELBOW	4P03B	5	
13						
14		WAC412	6"-4" REDUCER	6P11B	1	
15						
16		WAC413	4" END STOPS	S89	6	
17						
18		WAC414	4" PIPE 3 METERS LONG	4P01A3	3	
19						
20		ENC050	LOUVRES 300x300mm	RS 432-801	1	
21						
22						
23						
24						
25						
26						
27						
28						
29						
30						
31						
32						
33						
34						
35						
36						
37						
38						
39						
40						
41						
42						
43						
44						
45						
46						
47						
48						
49						
50						
	FORM	CF012		CRESTCHIC LIMITED		
	ISSUE	07		2ND AVENUE, CENTRUM 100,		
	ISSUE DATE	24/11/98		BURTON ON TRENT, STAFFS		
	AUTHORISED	M.W.B.		UNITED KINGDOM DE14 2WF		
				PHONE 00 44 (0)1283 531645		
				FAX 00 44 (0)1283 510103		



Crestchic Loadbanks
WORLDWIDE LOADBANK SPECIALISTS

14. TECHNICAL INFORMATION

Woods JM Aerofoil Fan (Standard Range)

- 315 mm - 1000 mm diameter
- Volume flow up to 20 m³/s
- Static pressures up to 700 Pa
- 100% X-ray of cast aluminium impeller components
- High energy efficiency
- Low installed noise levels
- Motor protection IP55
- Multi-stage for higher pressure development also available
- Casing hot dipped galvanised after manufacture

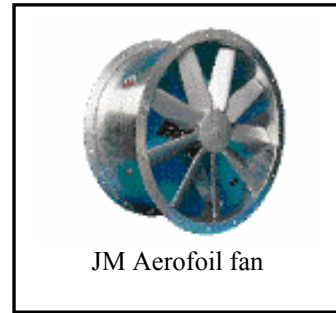

63JM fan units, 10 off used to cool resistive elements.

Voltage (V)	Freq (Hz)	Rev/min	Power (W)	Current (A)	p.f.
380/440	50	1440	3570	7.8	0.8
440/480	60	1760	4200	7.8	0.82

610mm fan diameter, F2249B frame size, 38° blade angle, 40°C maximum temperature, continuous.

500JM fan unit, 1 off used as exhaust fan for reactors and control hardware.

Voltage (V)	Freq (Hz)	Rev/min	Power (W)	Current (A)	p.f.
380/440	50	1440	830	2.28	0.77
440/480	60	1760	900	2.3	0.77

500mm fan diameter, CT9 frame size, 24° blade angle, 50°C maximum temperature, continuous.

The following sheets contain additional information: -

Woods air movement sheet 64
 Woods air movement declaration of conformity
 Crestchic Ltd drawing CL9282

Air Control Industries centrifugal fan

VBW7 fan unit, 2 off used as inlet fans for reactor cooling system.

Voltage (V)	Freq (Hz)	Rev/min	Power (W)	Current (A)	p.f.
380/420 Y	50	2870	1100	2.5	0.85
220/240 D	50	2870	1100	4.3	0.85

LM6 frame size.

The following sheets contain additional information: -

ACI datasheet vbw7
 Crestchic Ltd drawing CL9309

Crestchic Ltd resistive elements

The resistive elements used within Crestchic load banks are long life maintenance free items. If an element were to blow or become damaged in any way, this would affect the loading of the electrical supply under test.

Elements cannot be repaired and replacement elements would have to be installed, these can be obtained from Crestchic Ltd **only** (Please specify kW rating and voltage).

Resistive element details.

Voltage (V)	Power (kW)	Current (A)		Torque setting of electrical connection
260	5555	21.36		2BA - 3Nm
260	1111	4.27		4BA - 1.5Nm

For physical details of resistive elements, please see Crestchic drawing CL5189 sheet 3.

Crestchic Ltd reactors.

Reactor units are custom made for Crestchic Ltd by Bromsgrove winding services Ltd and may only be purchased through Crestchic Ltd.

Reactor Details.

Power (kVAr)	A (mm)	B (mm)	C (mm)	D (mm)	E (mm)	Fixing holes (mm)	Torque setting of electrical connection
1.98	190	145	210	130	110	DIA 8	M5 - 3.5Nm
3.96	250	170	260	200	115	DIA 8	M5 - 3.5Nm
7.92	300	170	350	100	210	DIA 12	M5 - 3.5Nm
19.8	360	260	430	120	285	DIA 14	M6 - 7.2Nm
39.6	420	310	480	130	360	DIA 16	M8 - 17Nm
79.2	580	395	550	195	420	DIA 16	M10 - 28Nm
198	750	480	580	495	420	DIA 18	M10 - 28Nm
280	810	480	580	495	420	DIA 18	M10 - 28Nm

Earth strapping (fitted along large reactors) is secured with M12 connections at a torque setting of 45Nm. Dimensions A to E on above table refer to those shown on Crestchic drawing CL9313.

DIMENSIONS AND WEIGHTS

LONG CASED 315 - 1000 DIA - UP TO 315 HUB

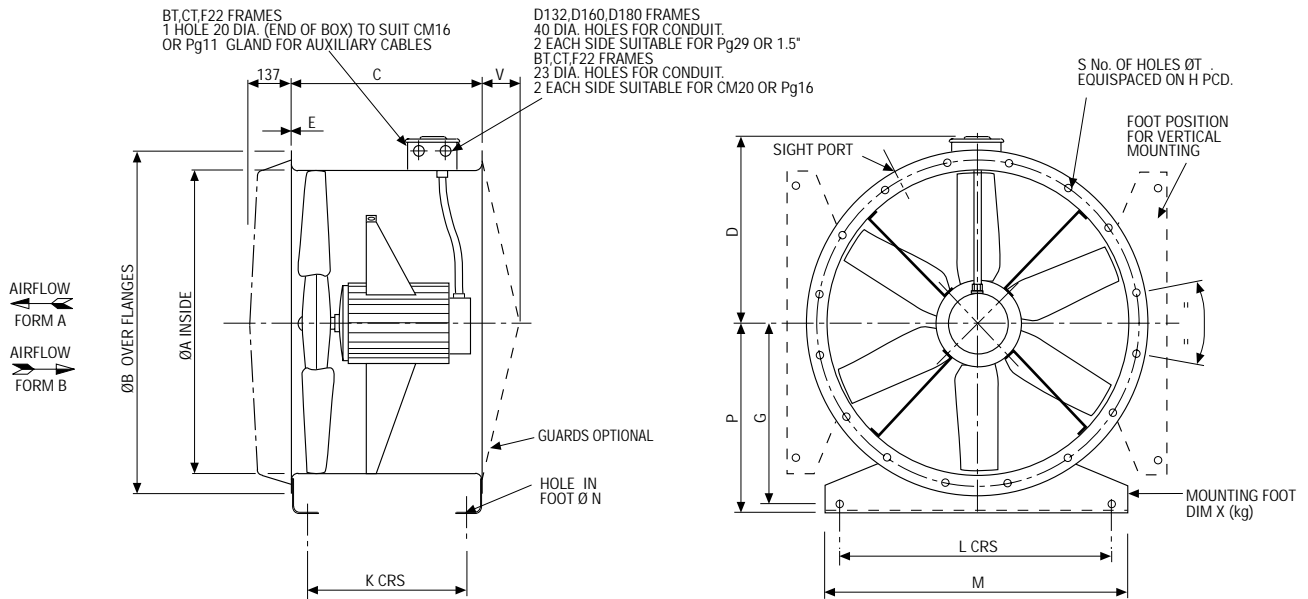

Code	Motor Frame	DIMENSION REFERENCE (mm)															Fan Weight (kg)	
		A	B	C	D	E	G	H	K	L	M	N	P	S	T	V		X
315	BT4/5/9	315	395	375	235	2.5	175	355	290	265	315	10	200	8	10	30	0.7	22
	CT5/9	315	395	375	235	2.5	175	355	290	265	315	10	200	8	10	30	0.7	27
355	BT4/5/9	355	435	375	256	2.5	200	395	290	305	355	10	225	8	10	30	0.9	24
	CT5/9	355	435	375	256	2.5	200	395	290	305	355	10	225	8	10	30	0.9	28
400	BT4/5/9	400	480	375	279	2.5	225	450	290	350	400	10	250	8	12	30	1.0	26
	CT5/9	400	480	375	279	2.5	225	450	290	350	400	10	250	8	12	30	1.0	30
450	BT4/5/9	450	530	375	306	2.5	255	500	290	400	450	10	280	8	12	30	1.2	28
	CT5/9	450	530	375	306	2.5	255	500	290	400	450	10	280	8	12	30	1.2	32
	F2225/45/65	450	530	520	306	3	255	500	424	400	450	10	280	8	12	30	1.2	44
	F2229/49/69	450	530	520	306	3	255	500	424	400	450	10	280	8	12	30	1.2	55
500	BT5/9	500	594	375	338	2.5	290	560	280	450	500	10	315	12	12	30	1.7	28
	CT5/9	500	594	375	338	2.5	290	560	280	450	500	10	315	12	12	30	1.7	34
	F2225/45/65	500	594	520	338	3	290	560	424	450	500	10	315	12	12	30	1.7	54
	F2229/49/69	500	594	520	338	3	290	560	424	450	500	10	315	12	12	30	1.7	65
560	BT5/9	560	654	375	368	2.5	330	620	280	510	560	10	355	12	12	50	2.0	34
	CT5/9	560	654	375	368	2.5	330	620	280	510	560	10	355	12	12	50	2.0	38
	F2225/45/65	560	654	520	368	3	330	620	424	510	560	10	355	12	12	50	2.0	56
	F2229/49/69	560	654	520	368	3	330	620	424	510	560	10	355	12	12	50	2.0	67
630	BT5/9	630	724	375	403	3	375	690	289	580	630	10	400	12	12	50	2.5	48
	CT5/9	630	724	375	403	3	375	690	289	580	630	10	400	12	12	50	2.5	52
	F2225/45/65	630	724	520	403	3	375	690	434	580	630	10	400	12	12	50	2.5	70
	F2225/49/69	630	724	520	403	3	375	690	434	580	630	10	400	12	12	50	2.5	81
	D132	630	724	520	440	4	375	690	432	580	630	12	400	12	12	50	4.8	127
D160	630	724	625	440	4	375	690	537	580	630	12	400	12	12	50	4.8	206	
710	CT5/9	710	804	375	443	3	415	770	259	660	710	10	440	16	12	50	4.5	54
	F2225/45/65	710	804	520	443	3	415	770	404	660	710	10	440	16	12	50	4.5	74
	F2229/49/69	710	804	520	443	3	415	770	404	660	710	10	440	16	12	50	4.5	85
	D132	710	804	520	480	4	415	770	402	660	710	12	440	16	12	50	5.3	139
	D160 *	710	804	625	480	5	415	770	505	660	710	10	440	16	12	50	5.3	205
D180 *	710	804	711	480	6	425	770	589	660	710	16	450	16	12	50	7.4	280	
800	CT5/9	800	894	375	488	3	485	860	259	750	800	10	510	16	12	50	7.0	63
	F2225/45/65	800	894	520	488	3	485	860	404	750	800	10	510	16	12	50	7.0	83
	F2229/49/69	800	894	520	488	3	485	860	404	750	800	10	510	16	12	50	7.0	94
	D132	800	894	520	525	5	485	860	400	750	800	12	510	16	12	50	7.0	163
	D160	800	894	625	525	5	485	860	505	750	800	12	510	16	12	50	7.0	220
D180 *	800	894	711	525	6	485	860	589	750	800	16	510	16	12	50	8.5	300	
900	F2225/45/65	900	1006	520	538	3	491	970	444	850	900	10	518	16	15	50	4.5	88
	F2229/49/69	900	1006	520	538	3	491	970	444	850	900	10	518	16	15	50	4.5	99
	D132	900	1006	520	575	5	491	970	440	850	900	12	518	16	15	50	5.3	183
	D160	900	1006	625	575	5	491	970	545	850	900	12	518	16	15	50	5.3	252
	D180	900	1006	711	575	6	491	970	629	850	900	12	518	16	15	50	5.3	312
1000	F2225/45/65	1000	1106	520	588	3	547	1070	444	950	1000	10	574	16	15	50	5.3	96
	F2229/49/69	1000	1106	520	588	3	547	1070	444	950	1000	10	574	16	15	50	5.3	107
	D132	1000	1106	520	625	5	547	1070	440	950	1000	12	574	16	15	50	6.2	198
	D160	1000	1106	625	625	5	547	1070	545	950	1000	12	574	16	15	50	6.2	268
	D180 *	1000	1106	711	625	6	547	1070	629	950	1000	16	574	16	15	50	12.5	328

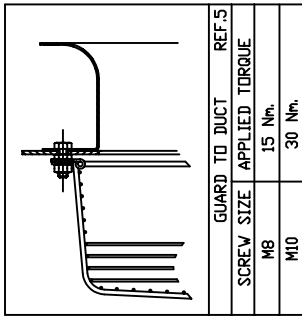

GUARD TO DUCT	REF.5
SCREW SIZE	APPLIED TORQUE
M8	15 Nm.
M10	30 Nm.

TO FIND TORQUES FOR HUBS SEE THE APPROPRIATE IMPELLER ASSEMBLY DRAWING-

IMPELLER ASSEMBLY	REF.2
LEFT HAND BLADE	RIGHT HAND BLADE
160 HUB: 247985	160 HUB: 251245
200 HUB: 248001	200 HUB: 251255
250 HUB: 247884	250 HUB: 251069
315 HUB: 251322	315 HUB: 251141
CLIMA IMPELLER ASSEMBLY: 244136	

HUB TO SHAFT	REF.1
ESLOK SIZE	APPLIED TORQUE
M5	3.5 Nm.
M6	6 Nm.
M8	15 Nm.
M10	30 Nm.
M12	50 Nm.
M16	120 Nm.

MAX BLADE DIAMETER = DI - 2.47mm
 MIN BLADE DIAMETER = DI - 3.88mm
 DI = DUCT INSIDE DIAMETER

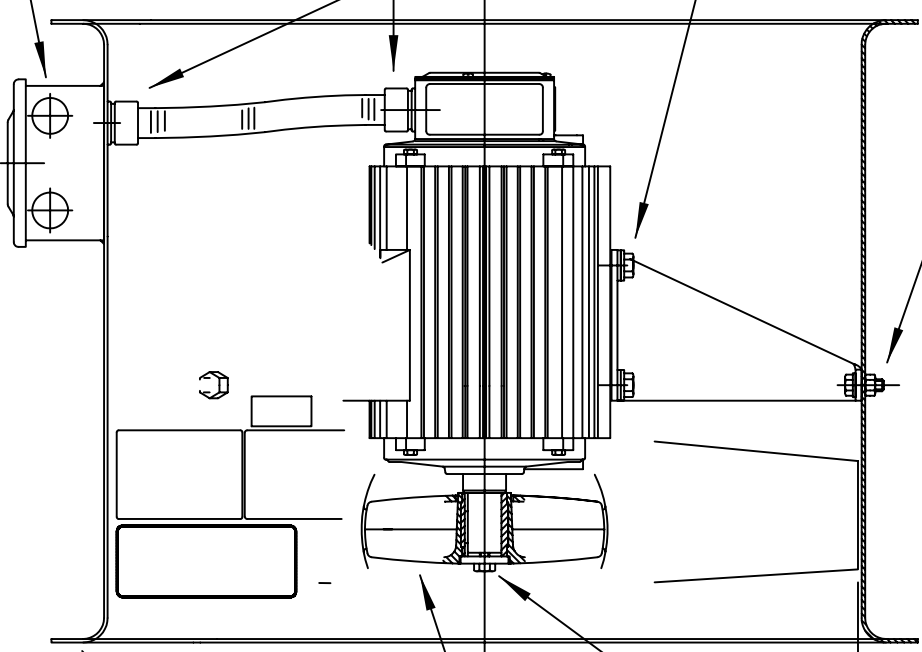

ARM TO DUCT	REF.3
SCREW SIZE	APPLIED TORQUE
M6	6 Nm.
M8	15 Nm.
M10	30 Nm.
M12	50 Nm.
M16	120 Nm.

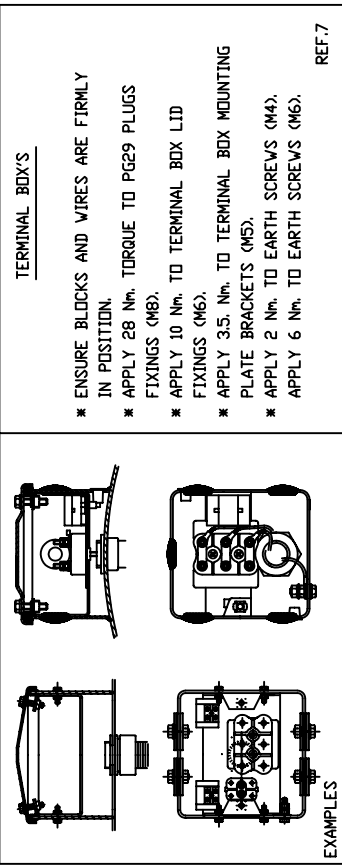

TERMINAL BOX'S

- * ENSURE BLOCKS AND WIRES ARE FIRMLY IN POSITION.
- * APPLY 28 Nm. TORQUE TO PG29 PLUGS FIXINGS (M8).
- * APPLY 10 Nm. TO TERMINAL BOX LID FIXINGS (M6).
- * APPLY 3.5 Nm. TO TERMINAL BOX MOUNTING PLATE BRACKETS (M5).
- * APPLY 2 Nm. TO EARTH SCREWS (M4).
- * APPLY 6 Nm. TO EARTH SCREWS (M6).

REF.7

CONDUIT CONNECTION TO DUCT AND MOTOR - ASSEMBLE CONNECTOR/LOCKNUT FINGER TIGHT AND THEN APPLY QUARTER TURN WITH SPANNER. N.B. THE AIM IS TO GET A GOOD STRONG FIXING, SO IF A QUARTER TURN IS NOT ENOUGH PLEASE APPLY MORE PRESSURE.

REF.6

SCREW SIZE	MOTOR FRAME	ARM TO MOTOR	REF.4
M8	BT		APPLIED TORQUE
M8	CT		15 Nm.
M12	F22		15 Nm.
M12	D80		36 Nm.
M12	D90		50 Nm.
M12	D100		50 Nm.
M12	D112		50 Nm.
M12	ENV89		50 Nm.
M12	DF100		25 Nm.
M12	DF112		25 Nm.
M16	DI32		135 Nm.
M16	DF132		60 Nm.
M20	DI60		200 Nm.
M20	DF160		120 Nm.

N.B. IN THE CASE OF FIXING ARM TO MOTOR IT IS ESPECIALLY IMPORTANT THAT THE CORRECT LENGTH FIXING IS USED TO ENABLE FULL THREAD ENGAGEMENT INTO THE MOTOR. FAILURE TO DO SO MAY RESULT IN BREAKDOWN.

ALL FIXINGS MUST BE DRY, NOT LUBRICATED

Customer: **Carl Hunter**
 Date: **09/08/01**
 Checked: **Harry Chamberlain**
 Issue Date: **01/08/05**
 Contract: **STANDARD**
 Scale: **DNS**
 Title: **FAN ASSEMBLY, TORQUE VALUES (TORQUE VALUES ALSO APPLY TO 2101 SERIES FANS)**
 Manufacturer: **Crestchic Loadbanks**
 Address: **2nd Avenue, Centrium 100, Burton-on-Trent, Staffordshire, DE14 2WF, United Kingdom.**
 Tel: **+44 (0)1283 531645** Fax: **+44 (0)1283 510103**
 ISO 9001 Registered, UKAS Manufacturing 015, WORLDWIDE LOADBANK SPECIALISTS
 Copyright © 2005 Crestchic Ltd.

DRAWN BY	DATE	ISSUE	DESCRIPTION
Carl Hunter	09/08/01	3	G.C.C.NSTD/128 GENERAL UPDATE
Harry Chamberlain	01/08/05	2	G.C.C.NSTD/57 NEW BORDER
STANDARD	DNS	1	CL9282



Centrifugal VBW7



pic: the basic VBW7

Single inlet centrifugal fan
 1741M³/Hr (1025CFM) free air for 2 pole
 1113M³/Hr (655CFM) free air for 4 pole

Motor type: Squirrel cage induction motor
 IP55 as std, IP65 available

Nominal supply: 220/240V or 115V 1Ph 50Hz
 380/420VY / 220/240VD 3Ph 50Hz
 440/480VY / 250/280VD 3Ph 60Hz

Standard ancillaries: Inlet and discharge guards/Spigots/Filters/
 Heat spinner

Materials: Fancase: cast aluminium LM6
 Impellers: galvanised sheet steel

Finishes: Stove enamel as std.

Mounting: Feet/Pedestal/Spigot

Noise levels: 94dB(A) for 2 pole/73dB(A) for 4 pole

Weight: 17Kg for 2 pole/13Kg for 4 pole

Outline drawings:

NOTE - Other specifications may be available on request

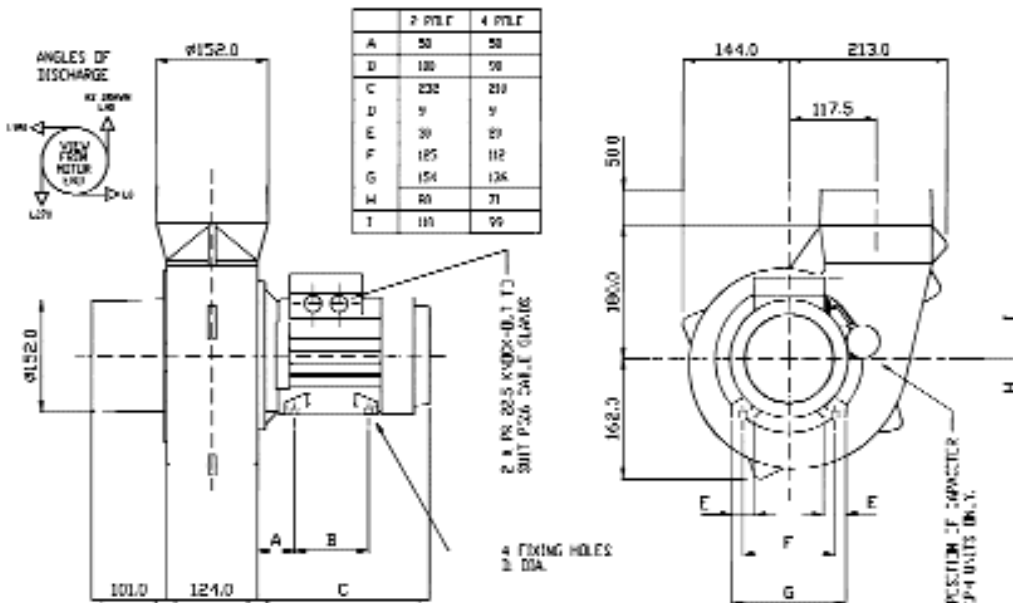

Performance details:

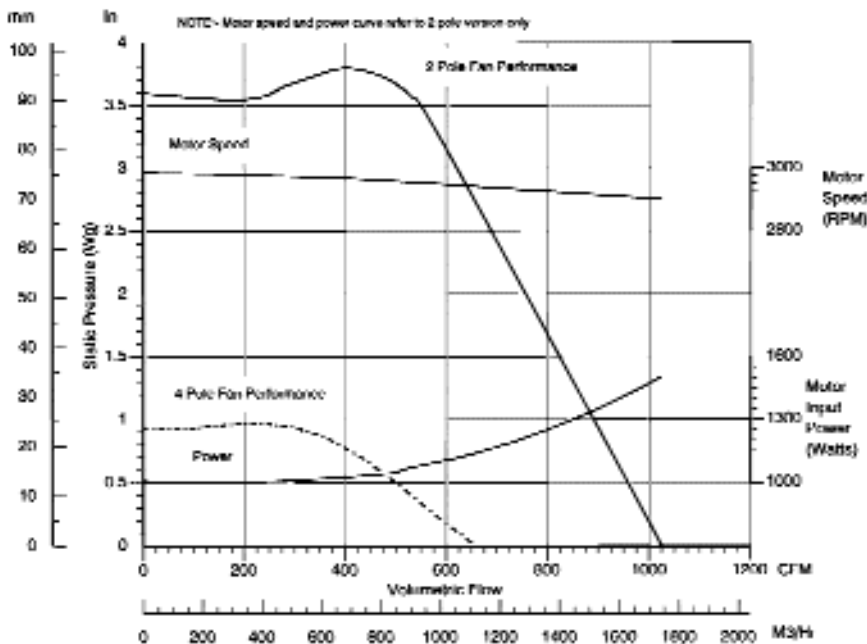

Ref: vbw7.00 Iss 3

Air Control Industries Ltd
 Silver Street - Chard - Somerset - UK - TA20 2AE
 Tel: 01460 67171 Fax: 01460 61700

Please note: A DWG File of this unit can be downloaded from www.air-con.co.uk



Certificate No. FM20497

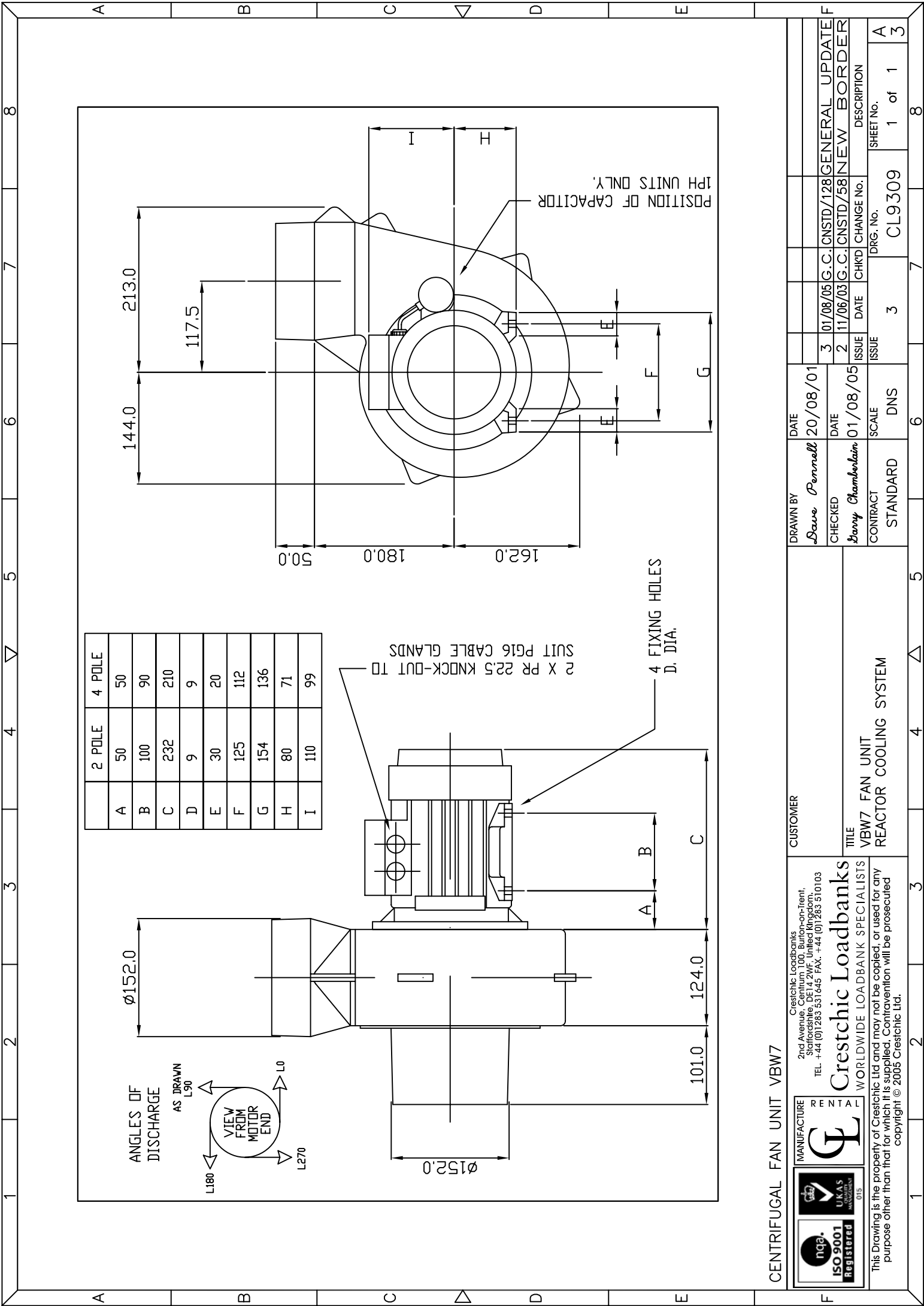

ANGLES OF DISCHARGE AS DRAWN L90 L180 L270

VIEW FROM MOTOR END

2 X PR 22.5 KNOCK-OUT TO SUIT PG16 CABLE GLANDS

4 FIXING HOLES D. DIA.

POSITION OF CAPACITOR 1PH UNITS ONLY.

101.0 124.0 152.0 152.0 162.0 180.0 184.0 213.0

A B C D E

1 2 3 4 5 6 7 8

CENTRIFUGAL FAN UNIT VBW7

Crestchic Loadbanks
 2nd Avenue, Centrum 100, Burton-on-Trent,
 Staffordshire, DE14 2WF, United Kingdom.
 TEL. +44 (0)1283 531645 FAX. +44 (0)1283 510103
Crestchic Loadbanks
 WORLDWIDE LOADBANK SPECIALISTS

CUSTOMER
 TITLE
 VBW7 FAN UNIT
 REACTOR COOLING SYSTEM

DRAWN BY
 Dave Pennell
 CHECKED
 Harry Chamberlain
 CONTRACT
 STANDARD

DATE
 20/08/01
 DATE
 01/08/05
 SCALE
 DNS

ISSUE	ISSUE	DRG. No.	SHEET No.
3	01/08/05	G.C.CNSTD/128	GENERAL UPDATE
2	11/06/03	G.C.CNSTD/58	NEW BORDER
1			

This Drawing is the property of Crestchic Ltd and may not be copied, or used for any purpose other than that for which it is supplied. Contravention will be prosecuted copyright © 2005 Crestchic Ltd.

DO NOT SCALE – IF IN DOUBT ASK!

DIM	ELEMENT – kW					
	1.666	1.333	1.111	1.000	0.666	0.333
A	50	50	50	50	50	50
B min.	553	553	553	553	330	330
B max.	576	576	576	576	343	343
C	25	25	25	25	25	N/A
D	8	8	8	8	8	8
E	M14	M14	M14	M14	M14	M14
F	17	17	17	17	17	30
G	M4	M4	M4	M4	M4	M4
NOMINAL SHEATH LENGTH	1132	1132	1132	1132	677	625
COLD SECTIONS	75-95	75-95	75-95	75-95	75-95	75-95

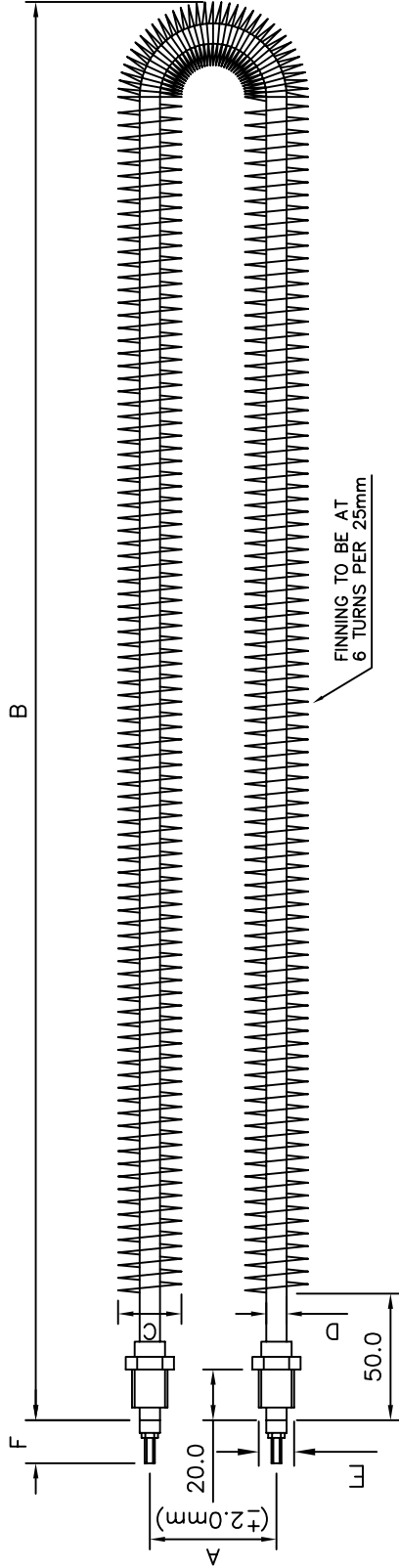
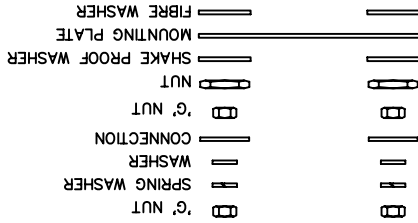

MANUFACTURING NOTES: –

- GENERAL NOTES & COMMENTS: –
 - NOMINAL ELEMENT DIAMETER TO SIZE 'D'
 - SHEATH MATERIAL 321 STAINLESS STEEL 0.6mm MINIMUM THICKNESS
 - ELEMENT IS OF AN HARPIN DESIGN AT CENTRES 'A' WITH CRIMPED BUSHES AT SIZE 'E'
 - BUSH CRIMP SECTION SEALED WITH RESIN AND CERAMIC ENDS ELECTRO-VARNISHED
 - TERMINAL PINS 'G' CROPPED 17.0mm FROM SHEATH END (exc. 166W) EACH C/W 1 BRASS HALF-NUT TO CERAMIC
 - 2 BRASS HALF-NUTS AND FIBRE WASHERS TO SIZE 'E' AND 2 BRASS HALF-NUTS & WASHERS TO SIZE 'G' TO BE SUPPLIED LOOSE WITH EACH ELEMENT

2. ELEMENT FINNING: –

- 304 STAINLESS STEEL FINNING 7.0mm WIDE 0.4mm THICK @ 6 TPI.
- FIN ENDS MUST BE BRAZED TO SHEATH
- 50.0mm UNFINNED SECTION AT EACH END

3. ELEMENT MARKING: –

- EACH ELEMENT TO BE CLEARLY MARKED WITH WATTAGE AND VOLTAGE – PERIPHERALLY 35.0mm FROM SHEATH END

4. SPECIAL TEST: –

- MINIMUM ISULATION RESISTANCE (COLD) – 100 MEG OHMS
- FLASH TEST – 1500V DC MIN

1.000kW ELEMENT SHOWN

3rd Angle Projection
 Dimensions are in millimetres
 General Fabrication Tolerances
 Up to 500mm ±0.5mm
 500 and over ±1.5mm

				Crestchic Loadbanks 2nd Avenue, Centrium 100, Burton-on-Trent, Staffordshire, DE14 2WF, United Kingdom. TEL. +44 (0)1283 531645 FAX. +44 (0)1283 510103		CUSTOMER MECHANICAL DETAILS RESISTIVE ELEMENT DETAILS		DRAWN BY <i>Karl Hunter</i>		DATE 05/11/91		6 04/01/06 G.C. CNSTD/134 DIMENSION UPDATE	
MANUFACTURE				WORLDWIDE LOADBANK SPECIALISTS		CHECKED <i>Harry Chamberlain</i>		DATE 04/01/06		5 01/08/05 G.C. CNSTD/128 GENERAL UPDATE		7 01/08/05 G.C. CNSTD/128 GENERAL UPDATE	
This Drawing is the property of Crestchic Ltd and may not be copied, or used for any purpose other than that for which it is supplied. Contravention will be prosecuted copyright © 2005 Crestchic Ltd.		ISO 9001 Registered		Crestchic Loadbanks		CONTRACT STANDARD		SCALE DNS		4 14/04/05 P.S. CNSTD/114 CHANGED TOL. ADDED 0/ALL SIZE		8 04/01/06 G.C. CNSTD/134 DIMENSION UPDATE	
TITLE MECHANICAL DETAILS RESISTIVE ELEMENT DETAILS		CUSTOMER		DATE 04/01/06		ISSUE 3		DATE 08/04/05		P.S. CNSTD/112 NOTES ADDED TO DRAWING		3 08/04/05 P.S. CNSTD/112 NOTES ADDED TO DRAWING	
STANDARD		DNS		ISSUE		CHANGE No.		DATE 06		DRG. No.		6 CL5189	
SHEET No.		1 of 4		8		7		4		5		3	

DO NOT SCALE - IF IN DOUBT ASK!

ELEMENT - kW	
DIM	5.555 3.333
A	65 65
B min.	728 567
B max.	758 577
C	32.5 32.5
D	11 10
E	$\frac{3}{8}$ " BSP $\frac{3}{8}$ " BSP
F	N/A 20
F1	17 N/A
G	2BA M4
NOMINAL SHEATH LENGTH 1495 1156	
COLD SECTIONS 75-90 85-95	

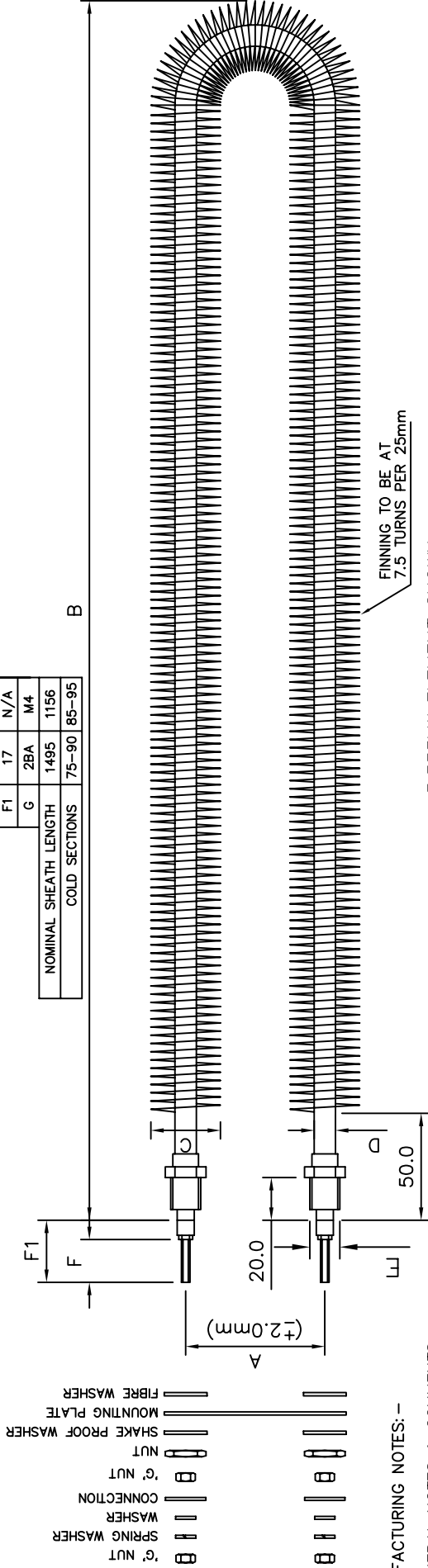

3.333kW ELEMENT SHOWN

MANUFACTURING NOTES: -

- GENERAL NOTES & COMMENTS: -
 - NOMINAL ELEMENT DIAMETER TO SIZE 'D'
 - SHEATH MATERIAL 321 STAINLESS STEEL OR INC 800 - 0.6mm MINIMUM THICKNESS
 - ELEMENT IS OF AN HARPIN DESIGN AT CENTRES 'A' WITH CRIMPED BUSHES AT SIZE 'E'
 - BUSH CRIMP SECTION SEALED WITH RESIN AND CERAMIC ENDS ELECTRO-VARNISHED
 - 5.555kW TERMINAL PINS 'G' CROPPED 17.0mm FROM SHEATH END EACH C/W 1 BRASS HALF-NUT TO CERAMIC
 - 3.333kW TERMINAL PINS 'G' CROPPED 20.0mm FROM NUT EACH C/W 1 BRASS HALF-NUT TO CERAMIC
 - 2 BRASS HALF-NUTS AND FIBRE WASHERS TO SIZE 'E' AND 2 BRASS HALF-NUTS & WASHERS TO SIZE 'G' TO BE SUPPLIED LOOSE WITH EACH ELEMENT
- ELEMENT FINNING: -
 - 304 STAINLESS STEEL FINNING 7.0mm WIDE 0.4mm THICK @ 7.5 TPI. (3.333kW) 6 TPI. (5.555kW)
 - FIN ENDS MUST BE BRAZED TO SHEATH
 - 50.0mm UNFINNED SECTION AT EACH END
- ELEMENT MARKING: -
 - EACH ELEMENT TO BE CLEARLY MARKED WITH WATTAGE AND VOLTAGE - PERIPHERALLY 35.0mm FROM SHEATH END
- SPECIAL TEST: -
 - MINIMUM ISULATION RESISTANCE (COLD) - 100 MEG OHMS
 - FLASH TEST - 1650V DC MIN

3rd Angle Projection
 Dimensions are in millimetres
 General Fabrication Tolerances
 Up to 500mm ±0.5mm
 500 and over ±1.5mm

		CUSTOMER Crestchic Loadbanks 2nd Avenue, Centrium 100, Burton-on-Trent, Staffordshire, DE14 2WF, United Kingdom. TEL. +44 (0)1283 531645 FAX. +44 (0)1283 510103		DRAWN BY Carol Hunter	DATE 05/11/91	G.C. CNSTD/134 NEW SHEET AND DIMENSION UPDATE 04/01/06	G.C. CNSTD/128 GENERAL UPDATE 01/08/05	P.S. CNSTD/114 IPI CHANGED TOL. ADDED 0/ALL SIZE 14/04/05	P.S. CNSTD/112 NOTES ADDED TO DRAWING 08/04/05
		TITLE MECHANICAL DETAILS RESISTIVE ELEMENT DETAILS		CHECKED Harry Chamberlain	DATE 04/01/06	ISSUE 6	CHANGE No. CL5189	DRG. No. CL5189	DESCRIPTION SHEET No. 2 of 4

This Drawing is the property of Crestchic Ltd and may not be copied, or used for any purpose other than that for which it is supplied. Contravention will be prosecuted copyright © 2005 Crestchic Ltd.

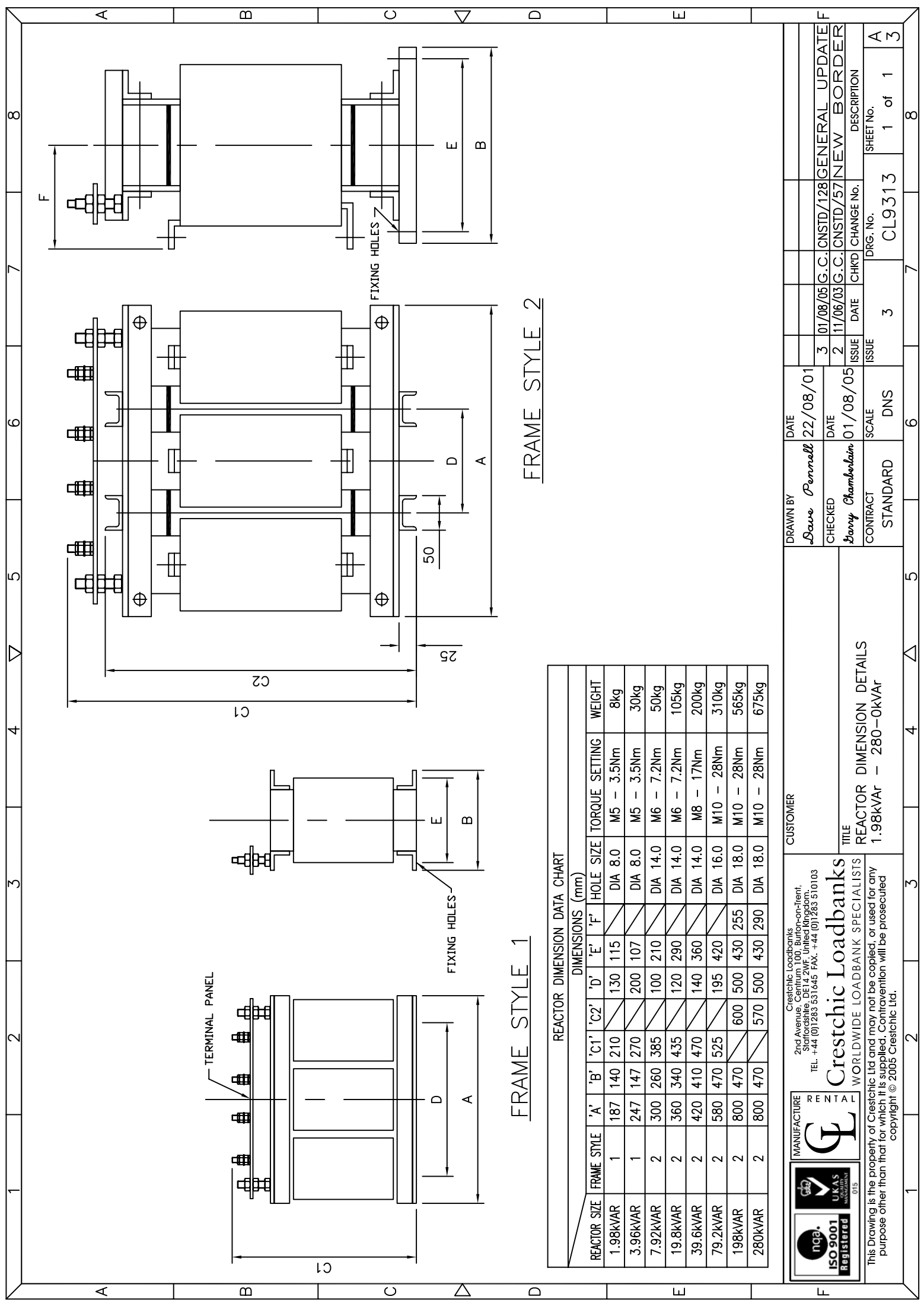

FRAME STYLE 1

FRAME STYLE 2

REACTOR DIMENSION DATA CHART										
REACTOR SIZE	DIMENSIONS (mm)									
	'A'	'B'	'C1'	'C2'	'D'	'E'	'F'	HOLE SIZE	TORQUE SETTING	WEIGHT
1.98kVAR	187	140	210	130	115	130	115	DIA 8.0	M5 - 3.5Nm	8kg
3.96kVAR	247	147	270	200	107	200	107	DIA 8.0	M5 - 3.5Nm	30kg
7.92kVAR	300	260	385	100	210	100	210	DIA 14.0	M6 - 7.2Nm	50kg
19.8kVAR	360	340	435	120	290	120	290	DIA 14.0	M6 - 7.2Nm	105kg
39.6kVAR	420	410	470	140	360	140	360	DIA 14.0	M8 - 17Nm	200kg
79.2kVAR	580	470	525	195	420	195	420	DIA 16.0	M10 - 28Nm	310kg
198kVAR	800	470	600	500	430	255	430	DIA 18.0	M10 - 28Nm	565kg
280kVAR	800	470	570	500	430	290	430	DIA 18.0	M10 - 28Nm	675kg

CUSTOMER

2nd Avenue, Centrium 100, Burton-on-Trent,
Staffordshire, DE14 2WF, United Kingdom.
TEL. +44 (0)1283 531645 FAX. +44 (0)1283 510103

MANUFACTURE

WORLDWIDE LOADBANK SPECIALISTS

This Drawing is the property of Crestchic Ltd and may not be copied, or used for any purpose other than that for which it is supplied. Contravention will be prosecuted copyright © 2005 Crestchic Ltd.

DRAWN BY <i>Dave Pennell</i>	DATE 22/08/01	G.C.C.NSTD/128		GENERAL UPDATE
CHECKED <i>Harry Chamberlain</i>	DATE 01/08/05	G.C.C.NSTD/57		NEW BORDER
CONTRACT STANDARD	SCALE DNS	ISSUE 3	CHANGE No. CL9313	DRG. No. CL9313
REACTOR DIMENSION DETAILS 1.98kVAR - 280-0kVAR			DESCRIPTION	SHEET No. 1 of 1
				8



Crestchic Loadbanks
WORLDWIDE LOADBANK SPECIALISTS

15. TEST RESULTS



Crestchic Loadbanks

WORLDWIDE LOADBANK SPECIALISTS

Contract Number

C3381

Delivery Date

W/E 25/08/06

Works Test Sheet

Customer Crestchic (Asia-Pacific) PTE LTD

Equipment Details

Load Supply Voltage _____ / 480 Volts
 Frequency 60 Hz
 Load Connections Star Delta 1-Phase

Auxiliary Supply Supply Voltage _____ / 480 Volts

Frequency 60 Hz
 AC Control Circuit Voltage 220 Volts
 Internal External Switched

Module Type Castor Mounted Trailer Mounted
 Permanent Installation
 Container 6ft 10ft 20ft
 Other _____
 Colour CAT YELLOW

Load Details

	Resistive		Reactive
Capacity	<u>2664.71</u> kW		<u>1994.82</u> kVAr
Resolution	<u>1.66</u> kW		<u>1.98</u> kVAr
Operating Code	<u>Micro</u>		

Controller Notes Solar Micro

NO LEADS
Stainless Steel Bulkheads

Test Engineer

 Crestchic Customer
 Date 15-8-06



Inspection & Test Procedure

Procedure

Notes

Items NOT Applicable to Equipment on Test to be Deleted by Test Engineer

1.0 Visual

- 1.1 Compare with the layout drawing for presence of all items. ✓
- 1.2 Inspect all busbars and connections for clearance. ✓
- 1.3 Inspect each item for dents and scratches. ✓
- 1.4 Check the presence and security of all covers, trunking, clips & screws. ✓
- 1.5 Inspect all screwed terminals for correctness (no loose strands, no bare conductors showing). ✓
- 1.6 Check presence of wire identification on all screwed terminals (colour codes & ferrules). ✓
- 1.7 Check the presence and rating of all bulbs in indication lamps. ✓
- 1.8 Check the presence and rating of all fuses. (Tick off against item list). ✓
- 1.9 Check the earth straps are fitted to all removable covers. ✓
- 1.10 Check position of wiring looms relative to any moving parts or sharp edges. ✓



Inspection & Test Procedure

Procedure

Notes

Items NOT Applicable to Equipment on Test to be Deleted by Test Engineer

2.0 Mechanical

- 2.1 Check all isolators, circuit breakers, switches and buttons for mechanical function. ✓
- 2.2 Check mechanical security of all transformers, contactors, relays, instruments and sensors. ✓
- 2.3 Individually check each fan for mechanical security and free rotation. ✓
- 2.4 Individually check tightness of each mounting bolt on all elements and busbars. ✓
- 2.5 Check correct fitting and security of fan guards. ✓

3.0 Electrical

3.1 Record Test Meters Used:-

- 3.1.1 Megger CIE 35
- 3.1.2 Multi-Meter CIE 38
- 3.1.3 Clamp on Meter(s) R CIE 17 + CT
- Y CIE 20
- B CIE 30

3.2 Measure and record the insulation resistance between neutral and earth. 31MR

3.3 Connect up and switch on power to the auxiliary supply circuitry. ✓

3.4 Check the control circuit voltage (refer to the front sheet). ✓

Form	Issue	Date	Authorised	Sheet No.
CF047	15	03.03.05	MWB	3 of 5



Inspection & Test Procedure

Procedure

Notes

Items NOT Applicable to Equipment on Test to be Deleted by Test Engineer

4.0 Electrical cont.

3.5 Check the fan(s) rotate in the correct direction. ✓

3.6 Check the delay between fans starting where appropriate. ✓

3.7 Check the functions of the following where appropriate (delete items not fitted):- ✓

3.7.1 Air-Flow Sensor Switches

3.7.2 Over Temperature Probes

3.7.3 Fan Overload Relays

3.7.4 Reset Button

3.7.5 Emergency Stop Button

3.7.6 Phase Rotation System

3.7.7 C.T. Sensing

3.7.8 *Remote Voltage Sensing*

3.7.9 _____

3.7.10 _____

3.7.11 _____

3.7.12 _____

3.8 Check Anti-Condensation/Lighting Circuit if fitted, mainly containers. ✓

3.9 Operate each contactor individually (on no load where possible). Check coil suppression modules are fitted. ✓

3.10 Load test the equipment and complete the table of results on CF048 (tolerance +5%). ✓

Form	Issue	Date	Authorised	Sheet No.
CF047	15	03.03.05	MWB	4 of 5



Crestchic Loadbanks
WORLDWIDE LOADBANK SPECIALISTS

Contract Number

C3381

Inspection & Test Procedure

Procedure

Notes

Items NOT Applicable to Equipment on Test to be Deleted by Test Engineer

3.0 Electrical cont.

- 3.11 Test the function of the extend facility where appropriate. ✓
- 3.12 Check the accuracy of all direct reading indication instruments and record the readings of each load step. ✓
- 3.13 Check all associated controllers and control leads. ✓

4.0 Serial Numbers

- 4.1 Record serial numbers of PCB's on CF100 if applicable. ✓

5.0 Drawings

- 5.1 Check the external diagram of connections is correct for proper installation of equipment. ✓

6.0 Completion of Clipboard

- 6.1 Test Sheets CF047 & CF048
- 6.2 CF100 if Applicable
- 6.3 CF138 Faults Report
- 6.4 CF015 Changer Request
- 6.5 CF129 if Applicable (=>400kW)
- 6.6 Parts List
- 6.7 Wiring Diagram
- 6.8 General Arrangement
- 6.9 Return CL6398 to Production
- 6.10 Return Clipboard to Engineering

Form	Issue	Date	Authorised	Sheet No.
CF047	15	03.03.05	MWB	5 of 5

2nd Avenue, Centrum 100, Burton-on-Trent, Staffs. U.K.
Tel. +44 (0) 1283 531645 Fax. +44 (0) 1283 510103



Crestchic Loadbanks

WORLDWIDE LOADBANK SPECIALISTS

Sheet of

Load Type

Micro Sheet

Contract Number	C3381	Date	15-8-06	Test Engineer	J. J. JOHNSON
------------------------	-------	-------------	---------	----------------------	---------------

Bit Code	Amps Cold			Measured	C.T. Calc.	ILS @ 240V		
	c.T. R	Clip On S	Clip On T			R-MP	R	R
0		1.9	1.9	242.2		1.9		1.88
1		3.5	3.6	242.2		3.6		3.56
2		3.7	3.7	242.3		3.6		3.56
3		7.2	7.0	241.7		6.8		6.75
4		17.9	17.5	242.0		17.5		17.35
5		35.3	35.5	241.5		35.3		35.08
6		35.4	35.9	241.6		35.4		35.16
7		70.9	69.9	240.3		70.4		70.31
8		175.3	174.7	237.4		175.9		177.82
9		174.9	175.0	237.3		176.5		178.50
10		174.9	175.6	237.2		176.5		178.58
11		173.0	173.5	237.8		174.9		176.51
12		173.6	173.8	237.7		174.2		175.88
13		172.3	172.9	237.6		174.2		175.95
14		173.3	173.3	237.8		173.6		175.20
15		174.9	174.5	237.5		176.8		178.66
16		175.0	175.0	237.4		176.2		178.12
17		175.7	175.4	237.1		177.3		179.46
18		175.3	175.8	236.8		177.3		179.69
19		175.1	175.3	237.4		175.6		177.52
20		174.9	175.0	237.2		176.7		178.78
21		175.0	175.7	237.7		176.2		177.90
22		175.1	176.0	237.7		176.6		178.30
23								

Bit Code	Amps Cold			Measured	C.T. Calc.	ILS @ 240V		
	(B) c.T. R	Clip On S	Clip On T			R-MP	R	R
9								
10								
11								
12								
13								
14								
15								
16								
17								
18								
19								
20								
21								
22								
23								



Crestchic Loadbanks

WORLDWIDE LOADBANK SPECIALISTS

Sheet of

Load Type

Micro Sheet

Contract Number	C3381	Date	15.8.06	Test Engineer	J. COOKE
------------------------	-------	-------------	---------	----------------------	----------

C.T. Ratio	Amps Cold			Measured	C.T. Calc.	ILS @ 240V		
	Bit Code	c.t. R	Clip On S			Clip On T	R-MP	R
0		2.5	2.5	242.5		2.6		2.57
1		5.3	5.3	242.3		5.9		5.84
2		5.4	5.2	242.6		5.8		5.73
3		10.1	10.6	242.1		11.1		11.00
4		26.8	26.7	241.3		28.1		27.94
5		48.1	47.5	240.9		48.3		48.11
6		91.6	90.9	239.7		92.2		92.31
7		203.8	202.9	237.1		204.8		207.30
8		338.1	328.7	234.5		339.6		347.56
9		342.6	341.9	234.2		344.5		353.03
10		338.7	338.6	233.9		340.5		349.538
11		337.6	336.9	234.1		338.4		346.92
12		336.8	335.1	234.2		339.4		347.80
13		342.9	341.6	234.2		344.7		353.23
14								
15								
16								
17								
18								
19								
20								
21								
22								
23								

Bit Code	Amps Cold			Measured	C.T. Calc.	ILS @ 240V		
	(B)	c.t. R	Clip On S			Clip On T	R-MP	R
9								
10								
11								
12								
13								
14								
15								
16								
17								
18								
19								
20								
21								
22								
23								

CALIBRATION CERTIFICATE

Date of Calibration: July 6, 2006 - 10:58

Coral SBC S/N: _____

DATA Module S/N: A9874/1/16/4/2006

INSTRUMENTS USED FOR CALIBRATION

	Description	S/N	Cal Expiry
1)	<u>XITRON 2503 AH</u>	<u>07664</u>	<u>10/06</u>
2)	<u>HAMMOND PCE 10A</u>	<u>59673</u>	<u>N/A</u>
3)	<u>FREQUENCY GEN.</u>	<u>FM9</u>	<u>10/06</u>
4)	<u>—</u>		
5)	<u>—</u>		

TRANSDUCER ZERO VALUES

Channel 00	(Frequency)	=	0.0000	=	45.0	Hz
Channel 01	(R-N Voltage)	=	0.0002	=	0.1	Volts
Channel 02	(S-N Voltage)	=	0.0002	=	0.1	Volts
Channel 03	(T-N Voltage)	=	0.0000	=	0.0	Volts
Channel 04	(R Current)	=	0.0059	=	32.2	Amps
Channel 05	(S Current)	=	0.0056	=	30.9	Amps
Channel 06	(T Current)	=	0.0112	=	61.8	Amps
Channel 07	(R kWatts)	=	0.0007	=	0.0	kW
Channel 08	(S kWatts)	=	0.0005	=	0.0	kW
Channel 09	(T kWatts)	=	0.0007	=	0.0	kW
Channel 10	(R-S Voltage)	=	0.0000	=	0.0	Volts

Channel 11	(S-T Voltage)	=	0.0000	=	0.0	Volts
Channel 12	(T-R Voltage)	=	0.0000	=	0.0	Volts
Channel 13	(Channel 13)	=			Disabled	
Channel 14	(Channel 14)	=			Disabled	
Channel 15	(Channel 15)	=			Disabled	

TRANSDUCER 25% VALUES

Channel 00	(Frequency)	=	0.2503	=	50.0	Hz
Channel 01	(R-N Voltage)	=	0.2498	=	74.9	Volts
Channel 02	(S-N Voltage)	=	0.2496	=	74.9	Volts
Channel 03	(T-N Voltage)	=	0.2498	=	74.9	Volts
Channel 04	(R Current)	=	0.2491	=	1370.0	Amps
Channel 05	(S Current)	=	0.2508	=	1379.4	Amps
Channel 06	(T Current)	=	0.2525	=	1388.8	Amps
Channel 07	(R kWatts)	=	0.2508	=	7.2	kW
Channel 08	(S kWatts)	=	0.2527	=	7.3	kW
Channel 09	(T kWatts)	=	0.2505	=	7.2	kW
Channel 10	(R-S Voltage)	=	0.2474	=	128.5	Volts
Channel 11	(S-T Voltage)	=	0.2505	=	130.2	Volts
Channel 12	(T-R Voltage)	=	0.2508	=	130.3	Volts
Channel 13	(Channel 13)	=			Disabled	
Channel 14	(Channel 14)	=			Disabled	
Channel 15	(Channel 15)	=			Disabled	

TRANSDUCER 50% VALUES

Channel 00	(Frequency)	=	0.5001	=	55.0	Hz
Channel 01	(R-N Voltage)	=	0.5006	=	150.2	Volts
Channel 02	(S-N Voltage)	=	0.4991	=	149.7	Volts
Channel 03	(T-N Voltage)	=	0.5001	=	150.0	Volts
Channel 04	(R Current)	=	0.4994	=	2746.6	Amps
Channel 05	(S Current)	=	0.5004	=	2752.0	Amps
Channel 06	(T Current)	=	0.5038	=	2770.8	Amps
Channel 07	(R kWatts)	=	0.5021	=	14.5	kW
Channel 08	(S kWatts)	=	0.5009	=	14.4	kW
Channel 09	(T kWatts)	=	0.5033	=	14.5	kW
Channel 10	(R-S Voltage)	=	0.4991	=	259.4	Volts
Channel 11	(S-T Voltage)	=	0.5004	=	260.0	Volts
Channel 12	(T-R Voltage)	=	0.5009	=	260.2	Volts
Channel 13	(Channel 13)	=			Disabled	
Channel 14	(Channel 14)	=			Disabled	
Channel 15	(Channel 15)	=			Disabled	

TRANSDUCER 75% VALUES

Channel 00	(Frequency)	=	0.7514	=	60.0	Hz
Channel 01	(R-N Voltage)	=	0.7507	=	225.2	Volts
Channel 02	(S-N Voltage)	=	0.7509	=	225.3	Volts
Channel 03	(T-N Voltage)	=	0.7514	=	225.4	Volts
Channel 04	(R Current)	=	0.7490	=	4119.3	Amps
Channel 05	(S Current)	=	0.7487	=	4117.9	Amps
Channel 06	(T Current)	=	0.7531	=	4142.1	Amps
Channel 07	(R kWatts)	=	0.7504	=	21.6	kW
Channel 08	(S kWatts)	=	0.7519	=	21.7	kW
Channel 09	(T kWatts)	=	0.7526	=	21.7	kW
Channel 10	(R-S Voltage)	=	0.7499	=	389.7	Volts
Channel 11	(S-T Voltage)	=	0.7512	=	390.3	Volts
Channel 12	(T-R Voltage)	=	0.7509	=	390.2	Volts
Channel 13	(Channel 13)	=			Disabled	

Channel 14	(Channel 14)	=		Disabled
Channel 15	(Channel 15)	=		Disabled

TRANSDUCER 95% VALUES

Channel 00	(Frequency)	=	0.9521	=	64.0	Hz
Channel 01	(R-N Voltage)	=	0.9519	=	285.6	Volts
Channel 02	(S-N Voltage)	=	0.9514	=	285.4	Volts
Channel 03	(T-N Voltage)	=	0.9509	=	285.3	Volts
Channel 04	(R Current)	=	0.9468	=	5207.2	Amps
Channel 05	(S Current)	=	0.9492	=	5220.6	Amps
Channel 06	(T Current)	=	0.9495	=	5222.0	Amps
Channel 07	(R kWatts)	=	0.0005	=	0.0	kW
Channel 08	(S kWatts)	=	0.0007	=	0.0	kW
Channel 09	(T kWatts)	=	0.0007	=	0.0	kW
Channel 10	(R-S Voltage)	=	0.9519	=	494.6	Volts
Channel 11	(S-T Voltage)	=	0.9497	=	493.5	Volts
Channel 12	(T-R Voltage)	=	0.9514	=	494.3	Volts
Channel 13	(Channel 13)	=			Disabled	
Channel 14	(Channel 14)	=			Disabled	
Channel 15	(Channel 15)	=			Disabled	

The Calibration for this Instrumentation Assembly is valid for twelve months from the above date.

Engineer's Signature: _____

