

DD29/DD31HF/DD38HF

DD29/DD31HF/DD38HF

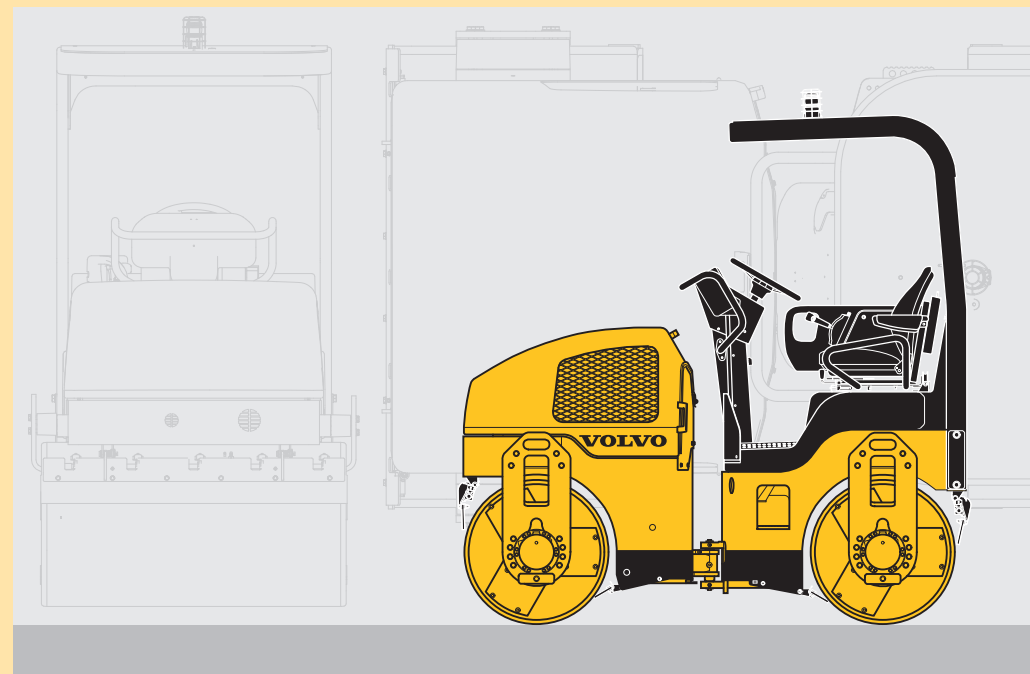

VOLVO

Volvo Construction Equipment
www.volvo.com

Ref. No. VOE21A1004089
CPN 43924968
Printed in Sweden 2008-05
Volvo, Shippensburg

English
CST

MORE CARE. BUILT IN.



**California
Proposition 65 Warning**

Diesel engine exhaust and some of its constituents are known to the State of California to cause cancer, birth defects, and other reproductive harm.

**California
Proposition 65 Warning**

Battery posts, terminals and other related accessories contain lead and lead compounds, chemicals known to the State of California to cause cancer and other reproductive harm.

Wash hands after handling.

TABLE OF CONTENTS

TITLE	PAGE
INTRODUCTION	1
INTRODUCTION	2
PROCEDURE WHEN RECEIVING THE MACHINE	3
IDENTIFICATION DATA	3
MACHINE IDENTIFICATION	3
ENGINE IDENTIFICATION	4
INSTRUCTION MANUAL STORAGE	4
GENERAL INFORMATION	5
MACHINE DESCRIPTION	5
DRUMS	5
ENGINE	6
MAIN FRAME	6
CONTROLS	6
DRUM WATER SPRAY SYSTEM	6
BRAKES	7
SERVICEABILITY	7
ROPS/SEAT BELT	7
SECTION 1 - SAFETY	1-1
SAFETY	1-2
BE AWARE OF SAFETY INFORMATION	1-2
UNDERSTAND SIGNAL WORDS	1-2
OVERVIEW	1-3
WARNINGS	1-3
GENERAL	1-3
SELECTION AND QUALIFICATION OF PERSONNEL	1-4
ORGANIZATIONAL MEASURES	1-4
PRE-START INSPECTION	1-5
SAFETY INSTRUCTIONS GOVERNING OPERATION	1-5
Starting	1-7
Operating	1-8
Stopping	1-9
Maintenance	1-9
WARNING OF SPECIAL DANGERS	1-12
TRANSPORTING, TOWING AND ROADING	1-12
HAZARDOUS SUBSTANCE PRECAUTION	1-14
SAFETY RELATED DECALS	1-15
U.S. DECALS	1-16
Crush Area	1-16
Rollover	1-16
Improper Operation	1-17
Rotating Fan Blade	1-17
Hot Fluid Pressure	1-17
Check List	1-18
INTERNATIONAL DECALS WITH INTERPRETATION	1-19
Crush Area	1-19
Rollover	1-19
Improper Operation	1-19
Rotating Fan and Belt	1-20
Radiator	1-20
Check List	1-21

TABLE OF CONTENTS

TITLE	PAGE
SECTION 2 - SYMBOL IDENTIFICATION	2-1
SYMBOL IDENTIFICATION	2-2
MACHINE SYMBOLS	2-2
INTERNATIONAL SYMBOLS	2-3
SECTION 3 - OPERATING CONTROLS AND INSTRUMENTS	3-1
OPERATING CONTROLS AND INSTRUMENTS	3-2
ARTICULATION LOCK BAR	3-2
CONTROLS AND SWITCH LOCATIONS	3-3
CONTROLS AND SWITCH DESCRIPTIONS	3-5
Auto Vibration Switch	3-5
Drum Selector Switch	3-5
Auto/Manual Water Pump Switch	3-5
Emergency Stop Switch	3-5
Steering Wheel	3-5
Hourmeter	3-5
Indicator Lights	3-6
Brake Test Switch	3-6
Park Brake Switch	3-6
Horn	3-6
Ignition Switch	3-6
Water Flow Control	3-6
Engine Speed Control (Throttle)	3-7
Propulsion Control Lever	3-7
Vibration ON/OFF Switch	3-8
SUSPENSION SEAT	3-8
OPTIONS	3-8
SECTION 4 - OPERATING INSTRUCTIONS	4-1
OPERATING INSTRUCTIONS	4-2
GENERAL INFORMATION	4-2
PRE-START CHECKS/VERIFICATIONS	4-3
STARTING MACHINE AND OTHER CHECKS/VERIFICATIONS	4-8
OPERATING THE MACHINE	4-11
Operating Suggestions and Checks While Operating Machine	4-11
Moving the Machine (Propulsion Control)	4-12
Using Vibration Controls: Operating the Machine Using Auto Vibration	4-14
Using Vibration Controls: Operating the Machine Using Manual Vibration	4-15
PARKING, STOPPING AND SHUTTING DOWN THE MACHINE	4-17
Parking the Machine	4-17
Stopping the Machine	4-17
Shutting Down the Machine	4-18
DAILY PRECAUTIONS AFTER WORK	4-18
MOUNTING AND DISMOUNTING OF ATTACHMENTS	4-19
MOVEMENT OF MACHINE BETWEEN WORK SITES	4-19
Loading the Machine Under its Own Power (Drive On) for Transporting	4-19

TABLE OF CONTENTS

TITLE	PAGE
Securing the machine to the transporter (Tie-down)	4-19
TOWING THE MACHINE: MODELS DD-29	4-20
TOWING THE MACHINE: MODELS DD-31HF/DD-38HF	4-22
SECTION 5 - MAINTENANCE INSTRUCTIONS	5-1
MAINTENANCE INSTRUCTIONS	5-2
GENERAL MAINTENANCE INFORMATION	5-2
Prior to conducting any maintenance work, ensure that the following instructions are observed:	5-2
Handling Fluids and Oil, Fuel Filters	5-3
INITIAL BREAK-IN MAINTENANCE	5-3
MAINTENANCE SCHEDULE	5-3
ROUTINE MAINTENANCE - AS REQUIRED	5-5
Check Air Cleaner Connections and Ducts for Leaks	5-5
Checking and Removing the Air Cleaner Primary Element	5-5
Clean the Primary Air Cleaner Element	5-7
Replace the Air Cleaner Elements	5-9
Clean/Wash/Lubricate the Machine	5-11
Prior to cleaning:	5-12
After cleaning:	5-12
Torque Loose Bolted Connections	5-12
Check all Shock Mounts	5-13
10 HOUR OR DAILY ROUTINE MAINTENANCE	5-13
Check Engine Oil Level	5-13
Check Engine Coolant Level, Clean Radiator and Oil Cooler	5-14
Check Air Cleaner	5-15
Check Air Cleaner Restriction Indicator	5-15
Check Fuel Level	5-16
Check Water Tank Level	5-17
Check Parking Brake	5-18
Clean Water Strainer	5-19
50 HOUR OR WEEKLY ROUTINE MAINTENANCE	5-20
Check Battery, Clean and Grease Terminals	5-20
Grease Articulation Pin Bearings	5-21
Grease Steering Cylinder Pin Bearings	5-21
Check Hydraulic Oil Level	5-22
Check Air Cleaner System Integrity and Filter Elements	5-23
Check Eccentric Oil Level	5-23
Check Engine Coolant Level	5-24
250 HOUR OR QUARTERLY ROUTINE MAINTENANCE	5-24
Change Engine Oil and Filter	5-25
Change Engine Fuel Filter Element and In-Line Fuel Filter	5-26
Purge Lube Carrier	5-28
Change Hydraulic Oil Filter	5-29
1000 HOUR OR ANNUAL ROUTINE MAINTENANCE	5-31
Drain, Clean and Fill Hydraulic Oil Tank	5-31
Drain and Flush Water Tank and Spray Bars	5-33
Change Eccentric Lube	5-34
Drain and Flush Radiator, Replace Engine Coolant	5-35
Change Air Filter Elements	5-38
Clean Fuel Tank	5-40

TABLE OF CONTENTS

TITLE	PAGE
SECTION 6 - TROUBLESHOOTING	6-1
TROUBLESHOOTING	6-2
PRE-START CHECK	6-3
Engine will not Start	6-3
Difficult Starting & Poor / Irregular Performance	6-4
Engine Makes Excessive Fumes	6-4
Engine Overheats - Stop Engine Immediately	6-5
Low Engine Oil Pressure - Red Warning Light Illuminates	6-5
Voltmeter Indicates Low or Negative Value	6-5
FUSE TROUBLESHOOTING	6-6
SECTION 7 - TECHNICAL SPECIFICATIONS	7-1
TECHNICAL SPECIFICATIONS	7-2
GENERAL IDENTIFICATION	7-2
ENVIRONMENTAL INFORMATION	7-3
MACHINE WEIGHTS AND FIGURES DD-29 / DD-31HF	7-6
MACHINE WEIGHTS AND FIGURES DD-38 HF	7-8
MACHINE DIMENSIONS DD-29 and DD-31HF	7-10
MACHINE DIMENSIONS DD-38 HF	7-11
SECTION 8 - FUEL AND LUBRICANT SPECIFICATIONS	8-1
FUEL AND LUBRICANT SPECIFICATIONS	8-2
GENERAL INFORMATION	8-2
SERVICE FUNCTIONS:	8-5
FLUID CAPACITIES	8-6
HYDRAULIC OIL REQUIREMENTS AND SPECIFICATIONS	8-7
LUBRICATING OIL/GREASE (EXCEPT ENGINE)	8-8
Extreme Pressure Multipurpose Lubricant	8-8
Extreme Pressure Multipurpose Grease	8-8
Synthetic Component Lubricant	8-9
ENGINE LUBRICATING OIL SPECIFICATIONS	8-10
DIESEL FUEL SPECIFICATIONS	8-10
HAZARDOUS SUBSTANCE PRECAUTION	8-11
SECTION 9 - TORQUE SPECIFICATIONS	9-1
TORQUE SPECIFICATIONS	9-2
SAE TORQUE CHART	9-2
ISO METRIC TORQUE CHART	9-3
DD-29/31HF/38HF SPECIAL TORQUE VALUES	9-4

TABLE OF CONTENTS

TITLE	PAGE
SECTION 10 - SCHEMATICS	10-1
SCHEMATICS	10-2
GENERAL INFORMATION	10-2
Electrical Schematics	10-2
Hydraulic Schematics	10-2
SECTION 11 - RECOMMENDED SPARE PARTS	11-1
Recommended Spare Parts	11-2

TABLE OF CONTENTS

TITLE

PAGE



INTRODUCTION

INTRODUCTION

The purpose of this manual is to provide the operator and site maintenance personnel with knowledge of the fundamental rules and criteria to be followed for the on-site use and maintenance of the DD-29/DD-31HF/38HF double-drum vibratory asphalt compactors.

This Operation and Maintenance Manual must be read and fully understood by the operator before operating the machine.

This manual consists of:

- INTRODUCTION describing the machine
- Section 1, SAFETY
- Section 2, SYMBOL IDENTIFICATION
- Section 3, OPERATING CONTROLS AND INSTRUMENTS
- Section 4, OPERATING INSTRUCTIONS
- Section 5, MAINTENANCE INSTRUCTIONS
- Section 6, TROUBLESHOOTING
- Section 7, TECHNICAL SPECIFICATIONS
- Section 8, FUEL AND LUBRICANT SPECIFICATIONS
- Section 9, TORQUE SPECIFICATIONS
- Section 10, SCHEMATICS
- Section 11, RECOMMENDED SPARE PARTS

Always keep the "Operation and Maintenance Manual" on the machine and within reach of the operating position.

If any part of this manual cannot be understood, contact your supervisor or local Distributor. This is an essential condition for working safely with this machine.

The correct machine operation, use, and regular maintenance are also essential elements to provide the highest performance and safety.

NOTE: This manual is accompanied with an engine operation and maintenance manual. You are, therefore, advised to follow the operation and maintenance manual instructions as specified in both the engine manual and this manual.

PROCEDURE WHEN RECEIVING THE MACHINE

Your machine has been tested, accurately checked, and prepared for shipment. Every part of the machine, including the detached parts, has been accurately checked before being shipped from the factory.

When you receive the machine, and before unpacking the equipment, check if damage has occurred during transport and if any parts are missing.

Check the equipment by consulting the shipment documents.

If goods are damaged or if parts are missing, inform the freight agent as soon as possible. They will inform you regarding how to proceed in order to make a complaint.

IDENTIFICATION DATA

An exact description of the model type and serial number of your machine will facilitate fast and efficient response from our parts and service operations.

Always provide the model of your machine and its serial number when you contact the local service or parts office.

We advise you to enter your machine data in the following lines to maintain machine and engine information:

Model

Serial No.

Year of Manufacture

Engine Serial No. and type of engine

MACHINE IDENTIFICATION

The machine identification plate (1, Figure 1) is located on the forward left side of the rear frame.

Figure 1



ENGINE IDENTIFICATION

The engine serial number is stamped on a nameplate (1, Figure 2) located on the right side of the engine.

Figure 2

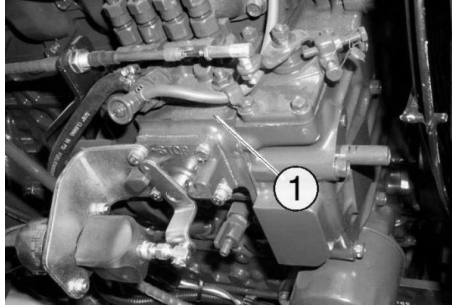

INSTRUCTION MANUAL STORAGE

A manual storage compartment (1, Figure 3) is located next to the operator's seat and provides space for the Operation and Maintenance manual.

Figure 3



GENERAL INFORMATION

All safety rules in Section 1 must be observed. If further information is required concerning the recommended use on asphalt applications, contact your local distributor or the following.

Volvo Construction Equipment

312 Volvo Way

Shippensburg, Pennsylvania 17257, USA

Tel : +1 - 717-532-9181

Fax : +1 - 717-530-3402 (Service and Warranty)

+1 - 717-530-3403 (Customer Service Parts)

The manufacturer reserves the right to make changes or modifications without prior notice and without incurring any liability to retrofit machines previously shipped from the factory.

MACHINE DESCRIPTION

Each compactor model offers the ideal combination of weight, drum width, frequency, centrifugal force and amplitude. The combination of these specifications results in the most efficient compaction of hot mix asphalt (H.M.A.) and non-cohesive soils.

DD-29 / DD-31HF / DD-38HF Compactors feature the Kubota V2203M engine and hydrostatic propulsion and steering systems. The hydrostatic propulsion system drives both drums for maximum gradeability.

DRUMS

To meet varying job requirements, the operator can manually control drum vibration or static and select dual drum or front drum.

DD-29 Compactor has an eccentric speed (the vibration power driving the drums) set at 4000 vibrations per minute (66.47 Hz).

DD-31HF and **DD-38HF** Compactors have the eccentric speed (the vibration power driving the drums) set at 4200 vibrations per minute (70 Hz).

ENGINE

All Models have the following features:

- Electric starting, belt driven alternator and battery are standard.
- A dry type, two-stage air cleaner system provides clean air to the engine. A dust discharging evacuator valve is provided on the air cleaner.
- Engine RPM is controlled by the throttle lever located on the pedestal. The engine is shutdown by either turning the ignition switch OFF or, in an emergency, by pressing the emergency stop switch.

DD-29 / DD-31HF / DD-38HF machines use water-cooled, heavy-duty, industrial diesel engines with 44 hp (32.8 kW) @ 2450 RPM.

MAIN FRAME

The machine consists of a front and rear frame which are connected by the swivel joint. The front frame includes an engine with drive pump and the hydraulic tank. The rear frame includes the seat and control console, water tank system, and fuel tank.

CONTROLS

All of the controls are positioned for operator convenience. The control panel contains the following standard controls and indicators: drum selector switch, hourmeter, emergency stop pushbutton, horn button, check engine light, brake test switch, and park brake switch with indicator light. In addition to the standard controls, there are controls for three options: pressurized water spray, driving lights, and beacon. All controls have ISO symbols indicating their functions.

Hand rails, skid-resistant decking, and toe plates promote safety.

Refer to Section 3 of this manual for a complete description of the controls and indicator lights.

DRUM WATER SPRAY SYSTEM

A pressurized water spray system is standard. A knob located on the pedestal controls the amount of water to the drums. The system consists of a separate pump, spray bars, and hand-serviceable nozzles. The system can be operated in automatic mode, manual mode, or turned OFF when water spray is not required. The flow control permits added productivity over competitive models by allowing the operator to adjust and conserve water sprayed on the drums, thus, avoiding costly down time.

BRAKES

Service brakes are dynamic hydrostatic through the propulsion system. The secondary brakes are spring-applied, hydraulically released and are incorporated on both the front and rear drums for safety, reliability and maintenance-free operation. The secondary brakes activate automatically in the event of a power loss or can be activated by the operator with the park brake switch or E-Stop switch.

SERVICEABILITY

A light weight hood lifts to provide easy access to the engine, filters, and hydraulic components. The spring loaded drum wipers require little maintenance. A removable panel provides additional access for extensive repair.

ROPS/SEAT BELT

The manufacturer provides ROPS (rollover protective structure) and seat belts as standard equipment on all compactors. A foldable ROPS is available as optional equipment. ROPS used in conjunction with seat belts will lessen the possibility of death or serious injury in the event of a rollover.

WARNING

Your life may be endangered if the following are not complied with:

DO NOT operate this machine if the Rollover Protection Structure (ROPS) is structurally damaged, show cracks, is not properly secured as originally installed, or has been involved in a rollover.

DO NOT repair, modify, drill, weld on or add attachments to the ROPS unless authorized in writing by the manufacturer.

DO NOT operate the machine unless the seat belt conforming to SAE and/or ASAE standards is fastened.

Contact your dealer for complete inspection requirements and maintenance instructions.

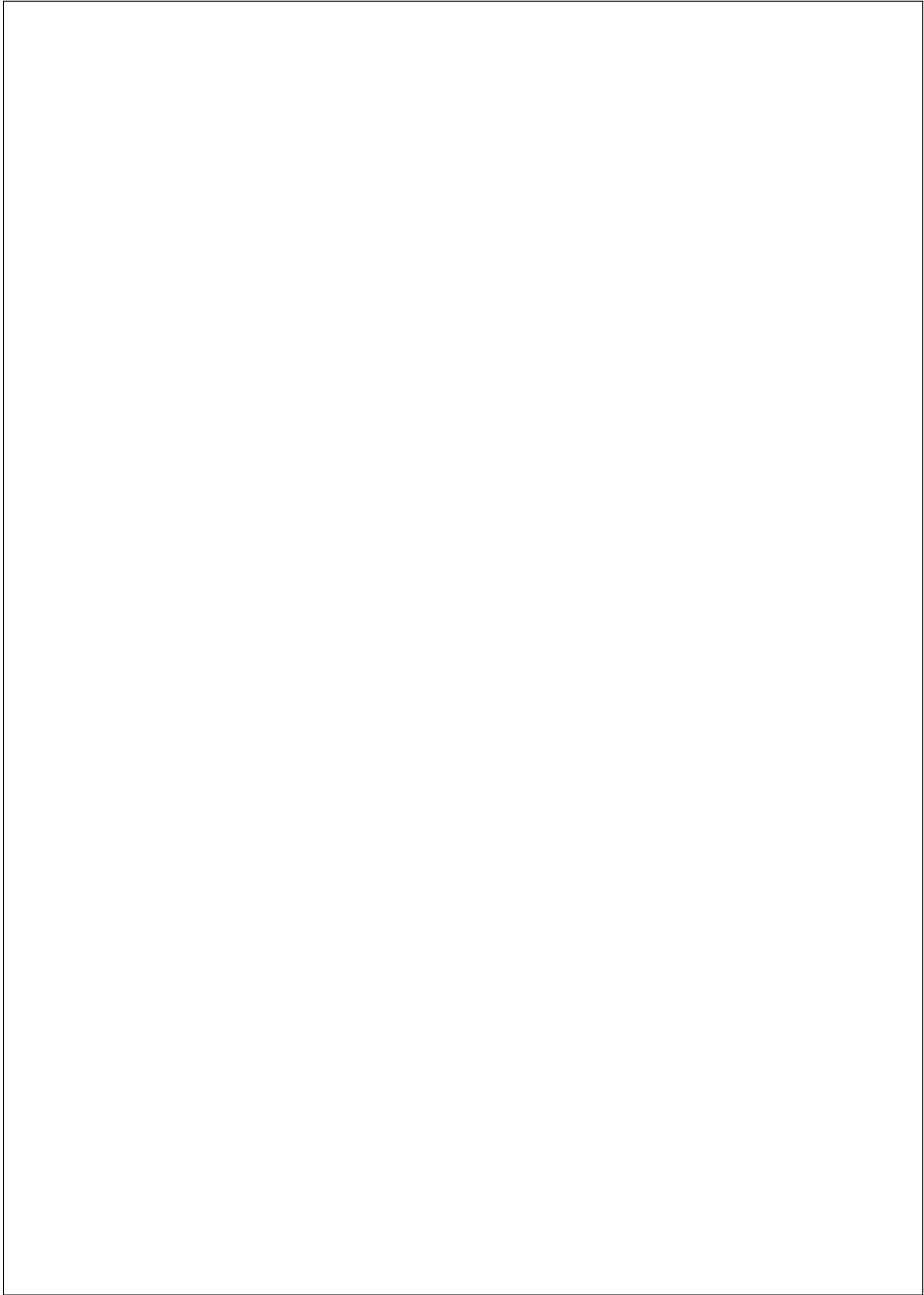



SECTION 1 - SAFETY

SAFETY

BE AWARE OF SAFETY INFORMATION

This is the Safety Alert Symbol. When you see this symbol in this manual, be alert to the potential for personal injury.

Follow recommended precautions and safe operating practices.

UNDERSTAND SIGNAL WORDS

A signal word - DANGER, WARNING, or CAUTION - is used with the safety-alert symbol. DANGER identifies the most serious hazard.

DANGER, WARNING, or CAUTION safety labels are located near specific hazards.

NOTICE labels are for general information.



This is the **SAFETY ALERT SYMBOL**. It is used to alert you to potential personal injury hazards. Obey all safety messages that follow this symbol to avoid possible injury or death.

 **DANGER**

(Red Background)

DANGER is used to indicate the presence of a hazard which will cause severe personal injury or death if the warning is ignored.

 **WARNING**

(Orange Background)

WARNING is used to indicate the presence of a hazard which can cause severe injury or death if the warning is ignored.

 **CAUTION**

(Yellow Background)

CAUTION is used to indicate the presence of a hazard which will or can cause personal injury, or property damage if the warning is ignored.

CAUTION

(Yellow Background)

CAUTION used without the Safety Alert Symbol indicates a potentially hazardous situation which, if not avoided, may result in property damage.

NOTICE

(Blue Background)

NOTICE is used to notify people of installation, operation, or maintenance information which is important but not hazard related.

OVERVIEW

BEFORE YOU OPERATE, MAINTAIN, OR IN ANY OTHER WAY USE THIS COMPACTOR:

READ and STUDY this manual. KNOW how to safely use the compactor's controls and what you must do for safe maintenance.

ALWAYS wear or use the proper safety items required for your personal protection.

If you have ANY QUESTIONS about the safe use or maintenance of this compactor, ASK YOUR SUPERVISOR OR CONTACT ANY DISTRIBUTOR. NEVER GUESS - ALWAYS CHECK!

WARNINGS

The following conventions are used in this manual to designate instructions of particular importance.

NOTE: Refers to special information on the efficient use of the machine.

NOTICE: Denotes special nonhazardous related information.

CAUTION: Refers to orders and prohibitions directed towards preventing minor personal injury or product/property damage.

WARNING: Refers to orders and prohibitions designed to prevent severe personal injury, death or extensive damage.

GENERAL

The manufacturer can not foresee all possible circumstances that might lead up to a potential hazard. Therefore, the combination of warnings listed in this manual and those placed on the machine itself are not intended to be all inclusive. Operators and maintenance personnel must be alert to recognize and avoid potential hazards. They should also have comprehensive training, required skills and necessary tools to properly perform their functions.

The machine was built in accordance with state-of-the-art standards and recognized safety rules. Nevertheless, its misuse may constitute a risk to life and limb of the user or of third parties, and may cause damage to the machine or other material property.

The machine must be used in accordance with its designated use as described in the operating and control sections of this manual. The machine must only be operated by safety-conscious persons who are fully aware of the risks involved in operating the machine. Any functional disorders, especially those affecting the safety of the machine, must be corrected immediately.

The machine is designed exclusively for the compaction of asphaltic road construction materials. Use of the machine for purposes other than that mentioned (such as for towing other vehicles/equipment) is considered contrary to its designated use. The manufacturer/supplier cannot be held liable for any damage resulting from such use. The risk of such misuse lies entirely with the user.

Operating the machine within the limits of its designated use also involves compliance with the inspection and maintenance directives contained in the operating section of this manual.

SELECTION AND QUALIFICATION OF PERSONNEL

Work on the machine must be performed by qualified personnel only. Statutory minimum age limits must be observed.

Individual responsibilities of the personnel responsible for operation, setup, maintenance and repair of the machine should be stated clearly.

Define the machine operator's responsibilities - also with regard to observing traffic regulations the operator should have the authority to refuse instructions by third parties that are contrary to safety.

Do not allow persons being trained or instructed in the operation or maintenance of the machine to work without permanent supervision by an experienced person.

Work on the electrical system and equipment of the machine must be done only by a skilled electrician or by instructed persons under the supervision and guidance of a skilled electrician and must be in accordance with electrical engineering rules and regulations.

Work on the chassis, brake, hydraulic and steering systems must be performed by skilled personnel with special knowledge and training for such work.

ORGANIZATIONAL MEASURES

STOW manuals in the compartment provided on the machine. Manuals must always be available at the site where the machine is being used.

OBSERVE AND INSTRUCT the user in all other generally applicable legal and mandatory regulations relevant to accident prevention and environmental protection. These compulsory regulations may also deal with the handling of hazardous substances, issuing and/or wearing of personal protective equipment, and traffic regulations.

SUPPLEMENT operating instructions with detailed working instructions pertaining to the specific work location.

ALWAYS be sure that persons entrusted with work on the machine have read the operating instructions and in particular the chapter on safety before beginning work. Reading the instructions after work has begun is too late. This is especially important for persons who work only occasionally on the machine, e.g. during set up or maintenance.

MAKE CERTAIN personnel are working in compliance with the operating instructions and are alert to risks and safety factors.

ALWAYS tie back or otherwise secure long hair, wear close-fitting garments and avoid wearing jewelry such as rings. Injury may result from clothing, hair, or jewelry being caught up in the machinery.

USE protective equipment wherever required by the circumstances or by law.

OBSERVE all safety instructions and warnings attached to the machine.

BE SURE all safety instructions and warnings attached to the machine are complete and perfectly legible.

STOP the machine IMMEDIATELY in the event of any malfunction. REPORT the malfunction to the proper authority/person.

NEVER provide service or maintenance to the machine unless the drum and wheels are adequately chocked, articulation lock bar/pin is in locked position, and parking brake is applied.

NEVER make any modifications to the machine which might affect safety without the manufacturer's approval. This applies to the installation and adjustment of safety devices and valves as well as to welding work on load bearing elements.

ALWAYS ADHERE to prescribed intervals or those specified in the operating instructions for routine checks and inspections.

PRE-START INSPECTION

INSPECT your compactor daily. Ensure that the routine maintenance and lubrication are being dutifully performed. Have any malfunctioning, broken, or missing parts repaired or replaced before use (see the Maintenance Schedule located in Section 5 of this manual).

VERIFY that all instruction and safety labels are in place and readable. These are as important as any other equipment on the compactor. Refer to the decal location drawing in Section 1 in this manual.

NEVER fill the fuel tank with the engine running, while near an open flame, or while smoking.

ALWAYS wipe up any spilled fuel.

CHECK for any maintenance and repair WARNING tags placed on the compactor by maintenance personnel. DO NOT operate the compactor until repairs have been made and the WARNING tags have been removed by authorized personnel.

CLEAN any foreign material from the operator's platform to reduce the danger of slipping.

KNOW the location of the Emergency Shut-Down Control.

ALWAYS know the capabilities and limitations of your equipment-speed, gradeability, steering, and braking.

BE AWARE of the dimensions of your compactor-height and weight-as well as your transporter dimensions and weight. Refer to illustrations included in this manual.

CHECK for any operating conditions that could be dangerous-such as holes, banks, underground culverts, manhole covers, water meter pits, curb and/or street boxes.

SAFETY INSTRUCTIONS GOVERNING OPERATION

AVOID any operational mode or procedure that might sacrifice safety.

TAKE all necessary precautions to ensure that the machine is used only when in a safe and reliable condition.

OPERATE the machine only if all protective and safety oriented devices, such as removable safety devices, emergency shut OFF equipment, soundproofing elements and exhausts, are in place and fully functional.

CHECK the seat belt regularly for wear or damage. Inspect belt hardware and fabric. Replace if hardware is damaged or if strap is nicked, frayed or loose stitching is found. Seat belt assemblies should be replaced every 3 years regardless of appearance. Seat belt strength degrades over time and use due to exposure to weather, UV (ultraviolet radiation) and abrasives (dirt). Check that mounting hardware is tight.

START the machine from the driver's seat only and always wear the seat belt.

WATCH the indicators during start up and shutdown procedures in accordance with the operating instructions. Refer to the lamp/indicator light check procedures in Section 5 of this manual.

MAKE SURE no one is at danger or risk before starting up or setting the machine in motion.

CHECK that braking, steering, signalling and lighting systems are fully functional before starting work or travelling with the machine.

CHECK that accessories have been safely stowed away before setting the machine in motion.

OBSERVE the valid traffic regulations when traveling on public roads and ways and **MAKE SURE** the machine is in a condition compatible with these regulations.

ALWAYS SWITCH ON the lighting system in conditions of poor visibility and after dark.

MAKE SURE there is sufficient clearance when crossing underpasses, bridges and tunnels or when passing under overhead lines.

ALWAYS KEEP at a safe distance from the edges of building pits and slopes.

AVOID any operation that might be a risk to machine stability.

NEVER CHANGE the speed range from LOW while compacting. On sloping terrain, always adapt your travelling and compacting speed to the prevailing ground conditions.

ALWAYS SECURE the machine against inadvertent movement and unauthorized use before leaving the driver's seat.

Starting

ALWAYS USE hand rails and steps to get on and off the compactor.

ALWAYS MAINTAIN a three-point contact when climbing onto or off of the compactor, as shown in Figure 1-1.

Figure 1-1

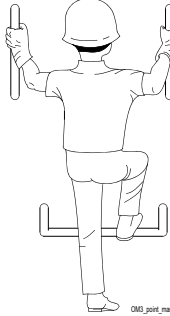

READ and FOLLOW ALL instruction decals.

ALWAYS be seated with the seat belt on when operating the machine.

BEFORE attempting to start the engine, ENSURE that the propulsion (travel) control is in the “STOP” position.

BEFORE starting the engine, ENSURE that the parking brake control is in the “Applied” position.

START the engine from the operator’s position only.

⚠ WARNING

NEVER jump start the compactor directly to the starter or starter solenoid. Severe injury or death could result from the compactor lurching forward or backward and running over the person(s) attempting to jump start the compactor. Normal safety devices are bypassed when jump starting the starter or starter solenoid directly.

ALWAYS USE EXTREME CAUTION if you have to jump-start the engine.

AVOID personal injuries by making sure that the compactor does not touch the other machine while it is being jump started.

NEVER jump start a frozen battery, as it will explode. While charging, lead acid batteries generate explosive gases.

KEEP sparks, flames and lighted smoking materials away from batteries.

ALWAYS wear safety glasses when working on or near batteries.

PROCEED as follows when jump starting the compactor:

- Connect the positive (+) terminal of the booster battery to the positive (+) terminal of the discharged battery.
- Connect the negative (-) terminal of the booster battery to the best ground point on the compactor, away from the battery.
- Follow all the recommended engine starting procedures.
- Remove the jumper cables in the reverse order of their connection as soon as the engine has started.

Operating

ALWAYS make sure that no person or obstruction is in your line of travel before starting the compactor in motion.

NEVER CLIMB onto or off of the compactor while it is in motion.

ALWAYS remain seated with the seat belt on when operating the compactor whether compacting, traveling, or loading/unloading.

USE EXTREME CAUTION and be very observant when operating in close quarters or congested areas.

NEVER carry passengers.

CLOSE all sound baffles during operation.

KNOW the area in which you are working. Familiarize yourself with work site obstructions and any other potential hazards in the area.

KNOW and USE the hand signals required for particular jobs and know who has the responsibility for signaling.

DO NOT work in the vicinity of overhanging banks or on grades that could cause the compactor to slide or roll over.

AVOID side hill travel. ALWAYS operate up and down slopes. ALWAYS keep the propulsion (travel) control lever in low speed range as close to the "STOP" position as practical when climbing or descending hills.

In the case of a rollover of a machine equipped with a factory installed cab, the cabin access door cannot be opened. The rear window and the right-hand window can be used as emergency exits.

NEVER allow anyone to stand within the compactor's articulation area when the engine is running.

ALWAYS LOOK in all directions BEFORE changing your direction of travel.

CONTROL the compactor travel speed with the LOW/HIGH speed control. When operating the compactor maintain the engine speed at full "Operating RPM."

DO NOT tow or push the compactor except as explained in Section 4 of this manual.

DO NOT release the brake(s) with any hydraulic or mechanical means prior to towing without tagging the compactor with a BRAKE RELEASED tag.

DO NOT run the engine in a closed building for an extended length of time. EXHAUST FUMES CAN KILL.

Stopping

ALWAYS park the compactor on solid level ground. If this is not possible, always park the compactor at a right angle to the slope and chock the wheels and drum.

AVOID leaving the operator's platform with the engine running. ALWAYS move the propulsion (travel) control to "STOP", apply the parking brake, install the articulation lock bar/lock pin, position the throttle control to "idle RPM", pull the fuel shut-off control (if so equipped), turn ignition switch to OFF, and lock all lockable compartments.

USE proper flags, barriers, and warning devices, especially when parking in areas of heavy traffic.

Maintenance

In any work concerning the operation, conversion or adjustment of the machine and its safety oriented devices or any work related to maintenance, inspection and repair, always observe the start up and shutdown procedures set out in the operating instructions and the information on maintenance work.

ENSURE that the maintenance area is adequately secured.

If the machine is completely shut down for maintenance and repair work, it must be secured against inadvertent starting by:

- locking the principal control elements and removing the ignition key and/or
- attach a warning sign to the main switch

CARRY OUT maintenance and repair work only if the machine is positioned on stable and level ground and has been secured against inadvertent movement and buckling.

USE CARE when attaching and securing lifting tackle to individual parts and large assemblies being moved for replacement purposes to avoid the risk of accidents. USE lifting gear that is in perfect condition and with adequate lifting capacity. NEVER work or stand under suspended loads.

ALWAYS USE the correct tools and workshop equipment when performing maintenance to the machine.

ALWAYS USE specially designed or otherwise safety oriented ladders and working platforms when doing overhead assembly work. Never use machine parts as a climbing aid.

KEEP all handles, steps, handrails, platforms, landings and ladders free from mud, dirt, snow and ice.

CLEAN the machine, especially connections and threaded unions, of any traces of oil, fuel or preservatives before carrying out maintenance/repair. NEVER use aggressive detergents. Use lint free cleaning rags.

Before cleaning the machine with water, steam jet (high pressure cleaning) or detergents, COVER OR TAPE up all openings which - for safety and functional reasons - must be protected against water, steam, or detergent penetration. Special care must be taken with electric motors and electronic equipment.

ENSURE during cleaning of the machine that temperature sensors do not come into contact with hot cleaning agents.

REMOVE all covers and tapes applied for that purpose after cleaning machine.

After cleaning, EXAMINE all fuel, lubricant, and hydraulic fluid lines for leaks, loose connections, chafe marks and damage. REPAIR or REPLACE defective parts immediately.

Always TIGHTEN any screwed connections that have been loosened during maintenance and repair.

Any safety devices removed for setup, maintenance or repair purposes must be refitted and checked immediately upon completion of the maintenance and repair work.

ENSURE that all consumable and replaced parts are disposed of safely and within environmental regulations.

AVOID, whenever possible servicing, cleaning, or examining the compactor with the engine running.

AVOID, whenever possible, servicing or providing maintenance to the compactor unless the drum and wheels are adequately chocked, parking brake applied and the articulation lock bar/lock pin is in the locked position.

NEVER fill the fuel tank with the engine running, while near an open flame, or while smoking. ALWAYS wipe up any spilled fuel.

DO NOT alter the engine governor settings from those indicated in the engine manual and the engine option plate.

ALWAYS replace damaged or lost decals. Refer to the parts manual for the proper location and part number for all decals.

ENSURE the safe operation, optimum performance, and safety of your warranty by using only genuine manufacturer replacement parts.

DISCONNECT the battery cables when working on the electrical system or when welding on the compactor.

BE SURE the battery area is well ventilated (clear of fumes) should it be necessary to connect a jump battery or battery charger. Fumes from the battery can ignite by a spark and explode.

BE SURE the battery charger is "OFF" when making the connections if battery charging is required.

Use only original fuses with the specified current rating. Switch OFF the machine immediately if trouble occurs in the electrical system.

Work on the electrical system and equipment of the machine must be done only by a skilled electrician or by instructed persons under the supervision and guidance of a skilled electrician and must be in accordance with electrical engineering rules and regulations.

If provided for in the regulations, the power supply to parts of machines, on which inspection, maintenance and repair work is to be carried out, must be cut OFF.

Before starting any work, check the de-energized parts for the presence of power and ground or short circuit them in addition to insulating adjacent live parts and elements.

The electrical equipment of machines is to be inspected and checked at regular intervals. Defects such as loose connections or scorched cables must be rectified immediately.

Welding, flame cutting and grinding work on the machine should only be done if expressly authorized, as there may be a risk of explosion and fire.

Before beginning welding, flame cutting and grinding operations, clean the machine and its surroundings from dust and other flammable substances and make sure that the premises are adequately ventilated (risk of explosion). Check all lines, hoses, and screwed connections regularly for leaks and obvious damage. Repair damage immediately. Splashed oil may cause injury and fire.

INSPECT hydraulic hoses at regular intervals and immediately replace them if they show signs of chafing, cracking, brittleness, leakage, fitting separation, corrosion or other damages which may affect their function and strength.

DO NOT work on hydraulic lines while the engine is running and the system is under pressure. The hydraulic fluid remains pressurized long after the engine has been stopped.

Depressurize all system sections and pressure pipes (hydraulic system, compressed air system) to be removed in accordance with the specific instructions for the unit concerned before carrying out any repair work.

DO NOT work on any hydraulic hose or fitting until the pressure has been **PROPERLY** relieved.

WAIT for hydraulic fluid to cool down before disconnecting lines. Hot hydraulic fluid will cause severe burns.

NEVER use your hands to check for leaks when inspecting a hydraulic system. Use a piece of cardboard and always wear gloves and safety glasses.

GET immediate attention if fluid has been injected under your skin. Fluid penetration from a pin hole leak can cause severe injury or death.

Hydraulic lines must be laid and fitted properly. Ensure that no connections are interchanged. The fittings, lengths and quality of the hoses must comply with the technical requirements.

When handling oil, grease and other chemical substances, observe the product related safety regulations.

Be careful when handling hot consumables (risk of burning or scalding).

WARNING OF SPECIAL DANGERS

When working with the machine, maintain a safe distance from overhead electric lines. If work is to be carried out close to overhead lines, the working equipment must be kept well away from them.

WARNING

If your machine comes into contact with a live electrical wire:

- **Do not leave the machine.**
- **Do not touch any control or any part of the machine.**
- **Warn others against approaching and touching the machine.**
- **Have the live wire de-energized.**
- **Do not leave the machine until the damaged line has been safely de-energized.**

Operate internal combustion engines and fuel operated heating systems only in adequately ventilated premises. Before starting the machine in enclosed premises, make sure that there is sufficient ventilation.

TRANSPORTING, TOWING AND ROADING

Use only appropriate means of transport and lifting gear of adequate capacity.

The fastening of loads and the instructing of crane operators should be entrusted to experienced persons only. The personnel giving the instructions must be within sight or sound of the operator.

DO NOT attempt to load the compactor on the transporter without knowledge and experience with the operation of the compactor.

Always use a ramp when loading the compactor on the transporter. Be sure ramps are of adequate strength, low angle, proper height and width.

When raising the unit off the ground, apply the parking brake and lock out the vehicle pivot point. Attach the lifting apparatus only to the unit's designated lifting points using properly rated lifting straps, cables, or chains. Use spreader bars to ensure equal weight distribution during lifting as well as avoid contact with the unit.

Use proper chock blocks in front and rear of the wheels of the transporter when loading the compactor.

Be sure the transporter is on level ground and approach the transporter loading ramps squarely to make sure the compactor does not drop off the side of the ramp.

Keep the transporter deck clean of clay, oil, mud, ice, frost and other material that can become slippery.

Position the compactor on the transporter or hauling vehicle centered from side to side and apply the brake.

Shut the engine OFF, apply the parking brake, and lock all lockable compartments following loading.

Use proper chock blocks in front and rear of the compactor drum and wheels once loaded onto the transporter. Leave the chocks if the unit will be on the transport vehicle for an extended period of time without being moved.

Always be sure the articulation lock bar/lock pin is secured in the locked position before transporting the compactor.

Position the compactor on the transporter or hauling vehicle centered from side to side and apply the brake.

Secure the compactor to the deck of the hauling vehicle or transporter with adequate chains or cables, blocks, and securing equipment to meet local regulations.

Always know the overall height of the compactor and hauling vehicle. Observe height and weight regulations and at overhead objects be sure you can safely pass beneath them.

For proper towing instructions, refer to Section 4, OPERATING INSTRUCTIONS of this manual.

When moving the compactor on public access roads, obey all traffic regulations and be sure that the proper clearance flags, lights, and warning signs, including the "Slow Moving Vehicle" emblem, are properly displayed. Know your approximate stopping distance at any given speed.

Never turn corners at excessive speeds. Look in all directions before reversing your direction of travel.

HAZARDOUS SUBSTANCE PRECAUTION

The following information is provided to assist the machine owners and operators. Further information may be obtained by contacting your Distributor.

The following substances (Table 1-1) are contained in or emitted by this machine and may be hazardous to health if exposed to or used incorrectly.

Table 1-1: Hazardous Substance Precaution

The following substances are contained in or emitted by this machine and may be hazardous to your health if used incorrectly.	
SUBSTANCE	PRECAUTION
Antifreeze (Water-cooled engine)	Avoid ingestion, skin contact, and breathing fumes
Hydraulic Oil	Avoid ingestion, skin contact, and breathing fumes
Engine Lubricating Oil	Avoid ingestion, skin contact, and breathing fumes
Preservative Grease	Avoid ingestion, skin contact, and breathing fumes
Rust Preventative	Avoid ingestion, skin contact, and breathing fumes
Engine Fuel	Avoid ingestion, skin contact, and breathing fumes
Battery	Avoid ingestion, skin contact, and breathing fumes
SAE Gear Oil	Avoid ingestion, skin contact, and breathing fumes

The following substances may be produced during the operation of this machine and may be hazardous to your health.

SUBSTANCE	PRECAUTION
Engine Exhaust Fumes	Avoid breathing
Engine Exhaust Fumes	Avoid buildup of fumes in confined spaces
Electric Motor Dust (Brushes/Insulation)	Avoid breathing during maintenance
Brake Lining Dust*	Avoid breathing during maintenance
* Only on machines with dry axle brakes	

SAFETY RELATED DECALS

Figure 1-2 Decal Location

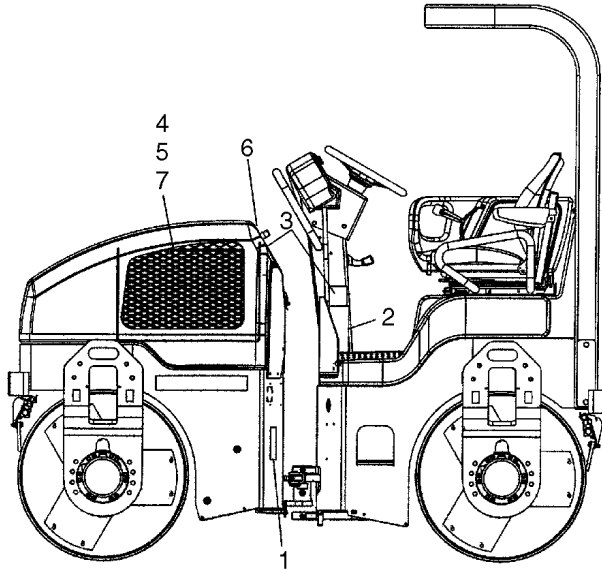

NO.	DECAL	NO. REQ'D.	LOCATION
1	WARNING: Crush Area	2	Frame (both sides)
2	WARNING: Rollover	1	Console
3	WARNING: Misoperation	2	Console and Hood
4	WARNING: Rotating Fan Blade	1	Side of radiator inside hood
5	WARNING: Hot Fluid Pressure	1	Top of radiator inside hood
6	Checklist	1	Hood
7	WARNING: Towing Tag	1	Inside hood on brake release valve

U.S. DECALS

1. Crush Area



2. Rollover

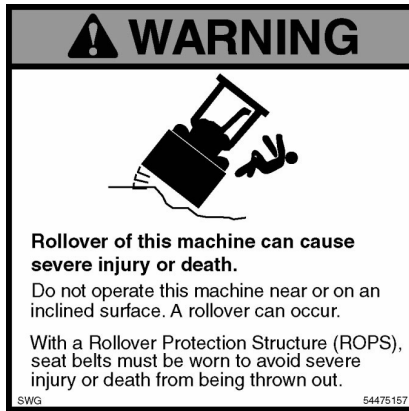

3. Improper Operation



































4. Rotating Fan Blade



5. Hot Fluid Pressure



6. Check List

PRE-STARTING	
<p>INSPECT FOR DAMAGE - Hoses, Safety Shrouds, Muffler, Engine, Railings, Fittings CHECK - Fluid Levels DO NOT OPERATE FAULTY EQUIPMENT ARTICULATION LOCK BAR - Disengage and stow</p>	
STARTING	
<p>CONSULT OPERATION AND MAINTENANCE MANUAL - SEE YOUR SUPERVISOR.</p> <p>  Propulsion Control Lever - CHECK IN STOP POSITION  Engine Speed - LOW IDLE  Parking Brake - APPLY  Emergency Stop Switch - RESET =  ↑ Work Area - CLEAR Ignition Switch - ON =  - BRAKE LIGHT - VERIFY ON - CHECK ENGINE LIGHT - VERIFY ON - START =  (30 seconds MAX.) - PREHEAT =  Preheat For Cold Weather Starting </p>	
OPERATING	
<p>  Seat Belt - FASTEN  Engine Speed - HIGH (Operating) IDLE  Parking Brake - RELEASE NOTE: Engine will stop within two seconds with weight off seat.  Water System - ON =  or  as applicable  Propulsion Control Lever - Move SLOWLY:  ←  →  - Move to STOP for NORMAL BRAKING </p> <p>  Vibration Control - ENGAGE ONLY WHILE IN MOTION  Select Vibration mode: Single Drum Vibration =  : Double Drum Vibration =  : Manual Vibration Control =  OR (if applicable) : Automatic Vibration Control =  </p> <p> Operation: Operating - STAY SEATED - SEAT BELT ON - ALLOW NO PASSENGERS - ALLOW NO PASSENGERS Up and Downhill Travel - GO SLOWLY </p>	
SHUT DOWN	
<p> Machine : - ON LEVEL SURFACE  Water System - OFF =   Vibration ON/OFF Switch - OFF  Parking Brake - APPLY  Engine Speed - LOW IDLE (For 3-4 mins.)   Ignition Switch - OFF =  </p>	
TRANSPORT	
<p> Machine : ON LEVER SURFACE Transport : Articulation Lock Bar - LOCK Machine - CHOCK - TIE DOWN SECURELY TO TRAILER Towing  DO NOT TOW UNTIL YOU REFER TO OPERATION AND MAINTENANCE MANUAL </p>	

SWG

54473434

INTERNATIONAL DECALS WITH INTERPRETATION**1. Crush Area**

Crush area can cause severe injury or death. Stay clear. Install lock pin before servicing.

2. Rollover

Rollover of this machine can cause severe injury or death. Do not operate this machine near or on an inclined surface. A rollover can occur. If this machine has a Rollover Protective Structure (ROPS), seat belts must be worn to avoid severe injury or death from being thrown out.

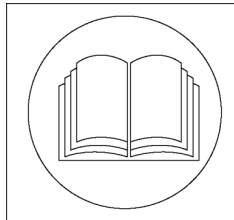
3. Improper Operation

Improper operation of this equipment can cause severe injury or death. Read and understand the operator's manual and safety instructions before operating or servicing.





























4. Rotating Fan and Belt

Rotating blade can cause severe injury. Do not operate with guards or shields removed. Stop machine before performing maintenance.

5. Radiator

Injury can occur when removing the radiator cap. Steam or fluid escaping from the radiator can burn. Rust Inhibitor contains alkali. Avoid contact with skin and eyes. Always shut down the engine and allow to cool before removing the radiator cap. Remove the cap slowly to relieve pressure. Avoid contact with steam or escaping fluid.

6. Check List

PRE-STARTING	
<p>INSPECT FOR DAMAGE - Hoses, Safety Shrouds, Muffler, Engine, Railings, Fittings CHECK - Fluid Levels DO NOT OPERATE FAULTY EQUIPMENT ARTICULATION LOCK BAR - Disengage and stow</p>	
STARTING	
<p>CONSULT OPERATION AND MAINTENANCE MANUAL - SEE YOUR SUPERVISOR.</p> <p>  Propulsion Control Lever - CHECK IN STOP POSITION  Engine Speed - LOW IDLE  Parking Brake - APPLY  Emergency Stop Switch - RESET =  Work Area - CLEAR Ignition Switch - ON =  </p> <p>  - BRAKE LIGHT - VERIFY ON  - CHECK ENGINE LIGHT - VERIFY ON START =  (30 seconds MAX.) PREHEAT =  Preheat For Cold Weather Starting </p>	
OPERATING	
<p>  Seat Belt - FASTEN  Engine Speed - HIGH (Operating) IDLE  Parking Brake - RELEASE NOTE: Engine will stop within two seconds with weight off seat. Water System - ON =  or  as applicable  Propulsion Control Lever - Move SLOWLY:  →  →  - Move to STOP for NORMAL BRAKING </p> <p>  Vibration Control - ENGAGE ONLY WHILE IN MOTION Select Vibration mode: Single Drum Vibration =  : Double Drum Vibration =  : Manual Vibration Control =  OR (if applicable) : Automatic Vibration Control =  </p> <p> Operation: Opeating - STAY SEATED - SEAT BELT ON - ALLOW NO PASSENGERS - ALLOW NO PASSENGERS Up and Downhill Travel - GO SLOWLY </p>	
SHUT DOWN	
<p> Machine : - ON LEVEL SURFACE Water System - OFF =  Vibration ON/OFF Switch - OFF  Parking Brake - APPLY  Engine Speed - LOW IDLE (For 3-4 mins.) Ignition Switch - OFF =  </p>	
TRANSPORT	
<p> Machine : ON LEVER SURFACE Transport : Articulation Lock Bar - LOCK Machine - CHOCK - TIE DOWN SECURELY TO TRAILER Towing  DO NOT TOW UNTIL YOU REFER TO OPERATION AND MAINTENANCE MANUAL </p>	
SWG	5447345

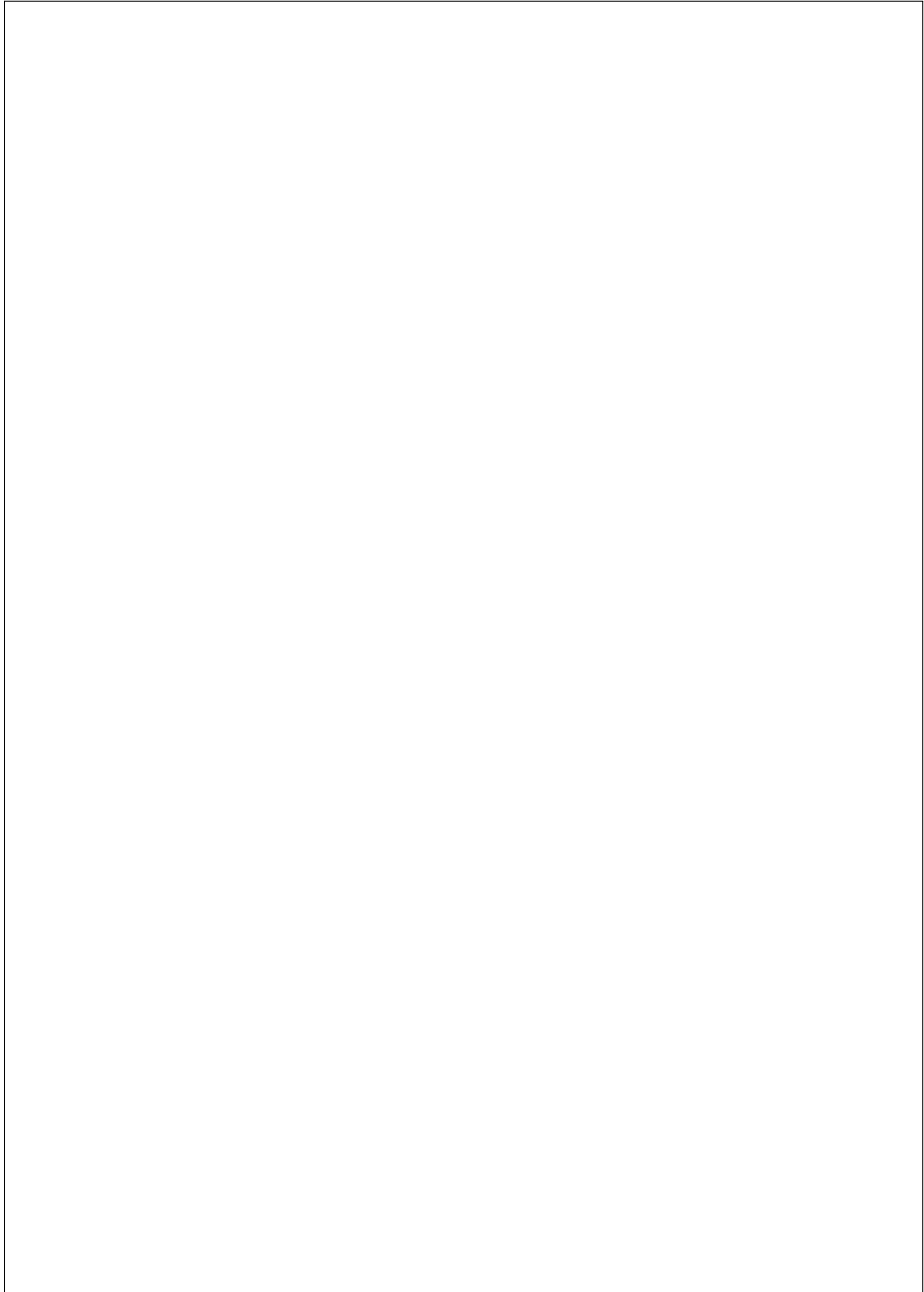















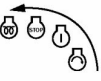

SECTION 2 - SYMBOL IDENTIFICATION

SYMBOL IDENTIFICATION

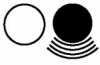
MACHINE SYMBOLS































































NOTE: Some symbols shown in this section may not appear on your machine.

 1	 2	 3	 4	 5	 6
 7	 8	 9	 10	 11	 12
 13	 14	 15	 16		

No.	Description	No.	Description
1	Drum Vibration	9	Anti-Drum Spin
2	Drum Vibration Control	10	Manual Vibration Control
3	High Amplitude	11	Water System Control
4	Low Amplitude	12	Double Drum Vibration Mode
5	Frequency (Vibration)	13	Single Drum Vibration Mode
6	Ignition Switch	14	Vibration Control Mode
7	Tie-down Point	15	Caution
8	Anti-Wheel Spin	16	Auto Vibration Control

INTERNATIONAL SYMBOLS

NOTE: Some symbols shown in this section may not appear on your machine.

 1	 2	 3	 4	 5	 6
 7	 8	 9	 10	 11	 12
 13	 14	 15	 16	 17	 18
 19	 20	 21	 22	 23	 24
 25	 26	 27	 28	 29	 30
 31	 32	 33	 34	 35	 36
 37	 38	 39	 40	 41	 42
 43	 44	 45	 46	 47	 48
 49	 50	 51	 52	 53	 54
 55	 56	 57	 58	 59	 60
 61	 62	 63			

SECTION 2

SYMBOL IDENTIFICATION

No.	Description	No.	Description
1	ON/Start	33	Engine Air Filter - Failure
2	OFF/Stop	34	Fan Belt - Failure
3	ON/OFF	35	Emergency Engine Stop
4	Plus/Positive	36	Engine Start
5	Minus/Negative	37	Engine ON/Run
6	Horn	38	Start Switch
7	Battery Condition	39	Transmission
8	Hourmeter	40	Transmission Oil Level
9	Seat (Lap) Belt	41	High Gear
10	Linear	42	Low Gear
11	Rotational	43	Forward Direction
12	Volume Empty	44	Reverse Direction
13	Volume Half-Full	45	Parking Brake
14	Volume Full	46	Brake ON
15	Grease	47	Brake OFF
16	Oil Lubrication Point	48	Primer (Start Aid)
17	Lift Point	49	Hydraulic Oil
18	Jack or Support Point	50	Hydraulic Oil Pressure
19	Filling/Emptying	51	Hydraulic Oil Level
20	Read Operator's Manual	52	Hydraulic Oil Filter
21	Engine Oil	53	Hydraulic Oil Temperature
22	Engine Oil Pressure	54	Fuel (Diesel)
23	Engine Oil Pressure - Failure	55	Fuel Level
24	Engine Oil Level	56	Fuel Filter
25	Engine Oil Filter	57	Work Light
26	Engine Oil Temperature	58	Flashing Beacon
27	Engine Coolant	59	Control Lever - Dual Direction
28	Engine Coolant Level	60	Control Lever - Multi Direction
29	Coolant Temperature	61	Clockwise Rotation
30	Engine Rotations (RPM)	62	Counterclockwise Rotation
31	Gas Inject (Cold Start)	63	Engine Electrical Preheat
32	Engine Air Filter		



SECTION 3 - OPERATING CONTROLS AND INSTRUMENTS

OPERATING CONTROLS AND INSTRUMENTS

WARNING

For your own safety and the safety of others, please ensure you thoroughly read and understand this section before operating the machine.

ARTICULATION LOCK BAR

WARNING

During shipment and before performing any checks or service operations, place the articulation lock bar in the locked position.

For compaction operation, the lock bar is to be removed from the locked position and placed in the stowed position.

Figure 3-1

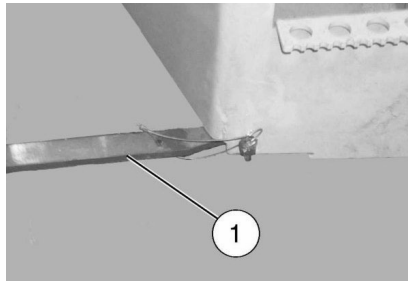

The articulation lock bar is used to prevent accidental articulation of the compactor. The lock bar must be in the locked position (1, Figure 3-1) prior to shipment and before performing any checks or service operations.

Place the lock bar in the stowed position (1, Figure 3-2) for compaction operations.

Figure 3-2

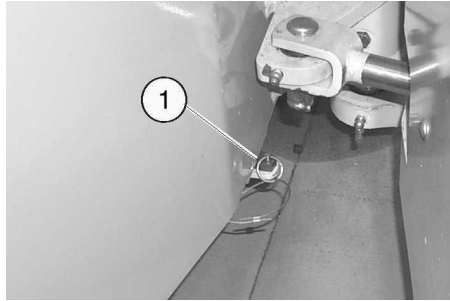

CONTROLS AND SWITCH LOCATIONS

Refer to Figure 3-3 and Figure 3-4 for locations of the following controls:

- | | |
|--------------------------|----------------------|
| 1. Auto Vibration Switch | 7. Indicator Lights |
| 2. Drum Selector Switch | 8. Brake Test Switch |
| 3. Water Spray Switch | 9. Park Brake Switch |
| 4. Emergency Stop Switch | 10. Horn Button |
| 5. Steering Wheel | 11. Ignition Switch |
| 6. Hourmeter | |

Figure 3-3

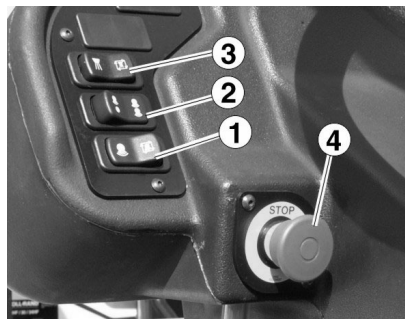
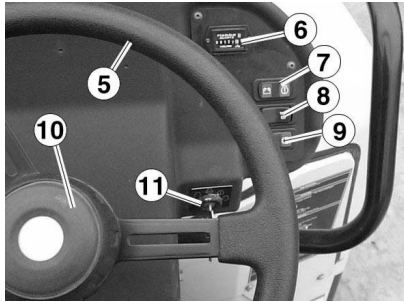

Figure 3-4



Refer to Figure 3-5 and Figure 3-6 for locations of the following controls:

12.	Water Flow Control	13.	Engine Speed Control (Throttle) Lever
14.	Propulsion Control (F-S-R) Lever	15.	Vibration ON/OFF Switch

Figure 3-5

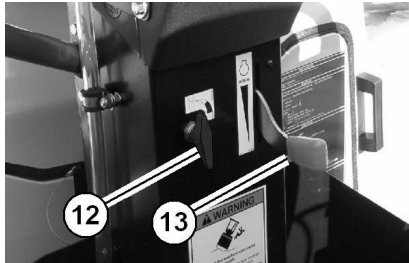
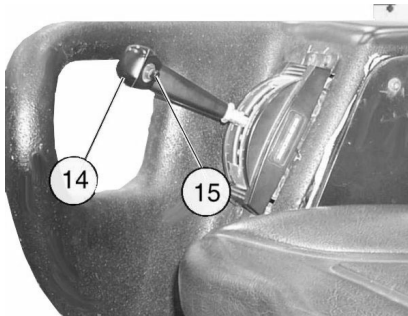

Figure 3-6



CONTROLS AND SWITCH DESCRIPTIONS

The following descriptions refer to Figure 3-3 through Figure 3-6.

Auto Vibration Switch

This two position rocker switch (1) is used to select the vibration mode. Pressing the right side of the switch activates AUTO vibration. Pressing the left side of the switch selects vibration ON. In AUTO mode, with the vibration pushbutton (15) switched ON, vibration will start automatically when the machine reaches a speed of approximately ½ mph. In the ON position, vibration is manually controlled by the Vibration ON/OFF switch (15).

Drum Selector Switch

This two position rocker switch (2) is used to select either front drum vibration or both drum vibration.

Auto/Manual Water Pump Switch

This three position switch (3) is used to control the main water pump. In Auto position, water spray turns on and OFF when the machine starts and stops respectively. In Manual mode, water spray operates continuously. The switch should be in the OFF (center) position whenever water spray is not required or when filling the water tanks.

Emergency Stop Switch

The Emergency Stop Switch (4) is a latching type switch that, when pressed, shuts down the engine and all other machine functions in the event of an emergency. To restart the machine after the e-stop has been activated, pull out on the switch and proceed with the start up procedure.

Steering Wheel

As the name implies, the steering wheel (5) is used to steer the machine.

Hourmeter

The Hourmeter (6) displays the run time for the engine. Maintenance recommendations are based on the engine operating hours.

Indicator Lights

The indicator lights (7) consist of two separate lights. A battery condition light and a check engine light. The battery condition light turns ON when there is a problem with the battery. The Check Engine Light turns ON whenever the ignition key is turned to the ON position to indicate that the system is operating correctly. The light will also turn ON if the engine has low oil pressure or high engine coolant temperature. If the Check Engine Light comes on during machine operation, shutdown the engine immediately and have service personnel determine the cause of the fault.

Brake Test Switch

The Brake Test Switch (8) is a momentary switch that allows the operator to test the operation of the Park Brake.

Park Brake Switch

This switch (9) turns the park brake ON and OFF.

Horn

Press the horn button (10) to sound the horn and alert personnel to the approaching machine or when changing direction.

Ignition Switch

This four-position switch (11) controls glow plug warm up engine starting, running, and stopping.

Water Flow Control

This Water Control lever (12) allows the operator regulate the amount of water that is supplied to the drums.

Engine Speed Control (Throttle) n/min

WARNING

Runaway machine.

Do not attempt to control machine travel speed with the engine speed control.

Use propulsion control to control travel speed. Maintain engine speed at operating RPM for all machine operations.

The engine speed control (13) is used to govern the engine speed (RPM). Pull control lever gradually upward to increase engine RPM. Push lever downward gradually to decrease engine RPM.

Propulsion Control Lever

The propulsion control (Forward-STOP-Reverse) lever (14) is used to control the forward and reverse movement and stopping of the compactor.

WARNING

Moving the propulsion control quickly may cause loss of machine control, lurching, or serious injury.

Move the control slowly.

To propel the machine in either the Forward or Reverse direction, gradually move the handle toward the desired direction.

To slow and stop travel of the machine, move the control slowly toward the STOP (center) position. Place the control lever at the STOP position for a complete halt of machine travel.

Vibration ON/OFF Switch

The Vibration ON/OFF switch (15) is used to manually activate and interrupt drum vibration. Press the switch once to activate drum vibration. Press switch again to deactivate drum vibration. See AUTO vibration switch (1) for a description of the vibration modes.

NOTE: In manual mode, vibration must only be activated when the machine is in motion. Always turn OFF vibration before the machine comes to a halt and never allow the drums to vibrate when the machine is stationary.

SUSPENSION SEAT

The machine is equipped with a suspension seat (1, Figure 3-7) that features several adjustments that enhance operator comfort. The seat (1) can be moved forward and backward, as well as from side to side on the operator's platform. Forward and backward seat movement is controlled by a lever (2, Figure 3-7) on the left side of the seat. Side to side seat movement is controlled by a lever (3, Figure 3-7) on the right side of the seat. In addition, a knob (4, Figure 3-7) on the front of the seat allows the operator to adjust the seat suspension for maximum comfort.

Figure 3-7

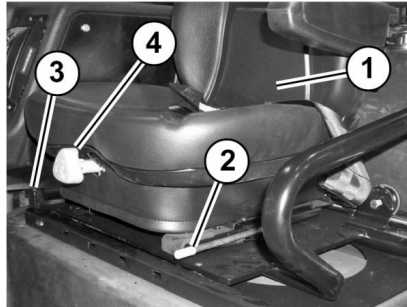

OPTIONS

In addition to the standard controls listed previously, there are some controls available for optional equipment. They are: Driving Light switch, and Beacon switch. Contact your Distributor for more information on these options.



SECTION 4 - OPERATING INSTRUCTIONS

OPERATING INSTRUCTIONS

If you are not experienced with the machine's operation and control, before operating the machine, read and understand Section 3, OPERATING CONTROLS AND INSTRUMENTS.

WARNING

Unexpected machine motion or moving parts can cut or crush.

Install the articulation lock bar, apply the parking brake and shutdown the engine before working on the machine.

WARNING

Improper maintenance can cause severe injury or death.

Read and understand Section 1, SAFETY which contains safety precautions and guidelines before you perform any maintenance, service or repairs.

GENERAL INFORMATION

Observe the following Operational procedures:

- Do not speed engine when it is cold.
- Always chock the drum/wheels when parking the machine.
- Do not grease the machine while the engine is running.
- Always perform safety checks prior to starting/using the machine.
- Do not control travel speed using the High/Low engine speed switch.
- Do not shift speed range selector at speeds above 5 km/h (3 mph).
- Always operate the machine at full engine speed when compacting or traveling the unit.
- Never operate the machine across slopes. Travel up and down slopes.
- On machines equipped with a Rollover Protective Structure (ROPS) wear seat belt at all times.

- Before starting engine, always check that propulsion control is at **STOP** position and that the parking brake is applied.
- Always sound the horn before moving the machine in either direction to alert personnel. Also allow sufficient time before putting machine into motion.
- Always use protective clothing such as gloves, goggles and safety helmet when performing service maintenance.

PRE-START CHECKS/VERIFICATIONS

Checks and verifications of overall machine must be performed prior to starting. Additional steps are listed in the 10 hour daily routine maintenance.

1. Fuel tank and fuel lines for any leaks.
2. Condition of engine and machine.
3. Bolted assemblies for tightness.
4. Inspect entire machine for any loose, worn and missing parts. Replace as needed.
5. Fluid lines, hoses, fittings, filler openings, drain plugs, pressure cap, drum, muffler, engine, safety shrouds and area underneath the machine for signs of leakage.

WARNING

Injury can occur when removing the radiator cap.

Steam or fluid escaping from the radiator can burn. Rust inhibitor contains alkali, avoid contact with skin and eyes.

Always shut down the engine and allow it to cool down before removing the radiator cap. Remove cap slowly to relieve pressure. Avoid contact with steam or escaping fluid.

6. Check engine coolant level in the coolant recovery bottle (1, Figure 4-1).

Coolant level should be at the "COLD FILL MIN" level mark on the bottle. Add a mixture of 50% coolant and 50% water to bring coolant to the proper level.

Coolant level must be maintained. Air will enter the coolant system if no coolant is present in the bottle.

Figure 4-1



- 7. Check fuel level gauge (1, Figure 4-2). If required, add clean, filtered fuel through the fill area (1, Figure 4-3). Use #2 diesel fuel.

Figure 4-2

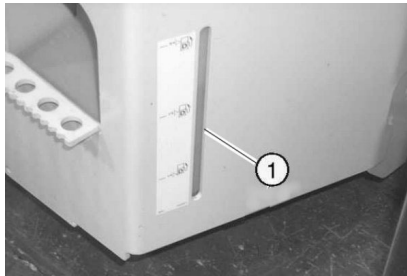
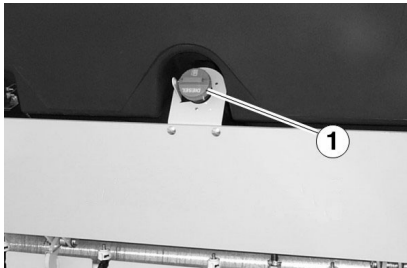
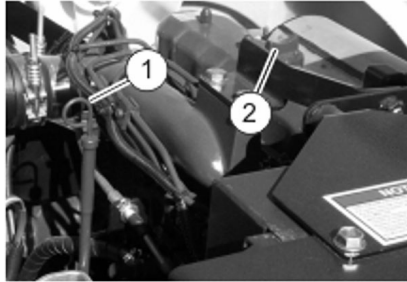

Figure 4-3



8. Check engine oil level on dipstick (1, Figure 4-4). If required, add motor oil through fill area (2, Figure 4-4) to bring to Full level on dipstick. Refer to the Engine manual for lube oil type. If no oil is showing on the dipstick, call for service assistance to investigate the cause of oil loss.

Figure 4-4



9. Check hydraulic oil level at gauge (1, Figure 4-5). Add fresh, clean, anti-wear, ISO Grade 46 hydraulic oil through the oil fill area (1, Figure 4-6). The fill area is accessed by opening engine hood. Be sure to install the fill plug.
10. Be sure water tank is full of fresh clean water before starting compaction operation. Keep tanks as full as possible during operation.

Figure 4-5

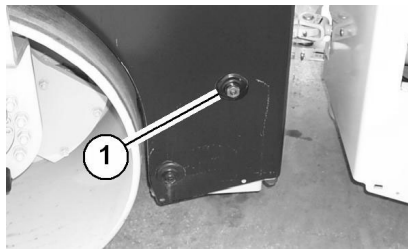
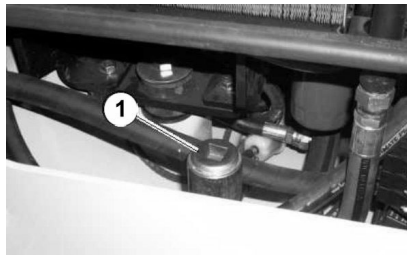
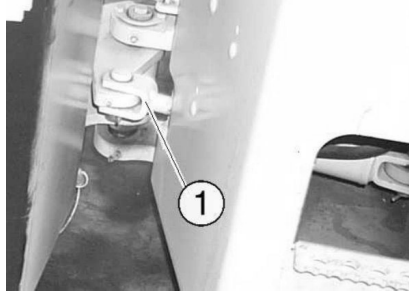

Figure 4-6



11. Check wear conditions on mounting pins and bushings of the steering cylinder (1, Figure 4-7). Any wear in the pins and bushings should be noted and proper personnel notified.

Figure 4-7



⚠ CAUTION

Any machine defects should be reported to the proper personnel.

Defects must be corrected before operating the machine.

Checks and verifications of machine controls must be performed prior to operating the machine.

12. Mount the compactor maintaining a three-point contact, as shown in Figure 4-8.

NOTE: The machine contains a circuit that will allow machine to start only if the propulsion control (13, Figure 4-9) is in neutral, the brakes are applied, and the Emergency Stop switch is reset.

Figure 4-8

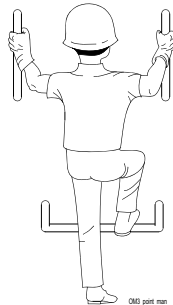

- 13. Securely fasten seat belt.
- 14. Position propulsion control ←  → (14, Figure 4-9) to the STOP (center) position.

Figure 4-9



- 15. Place engine speed control lever (13, Figure 4-10) to Low idle position.

Figure 4-10

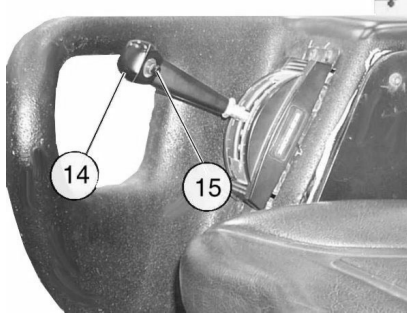
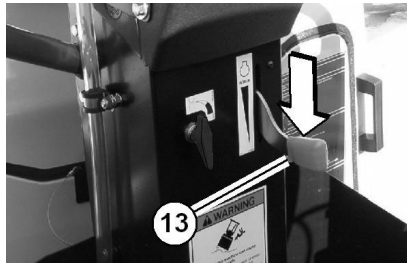

- 16. Apply parking brake by placing park brake switch (9, Figure 4-11) in the ON position.

Figure 4-11

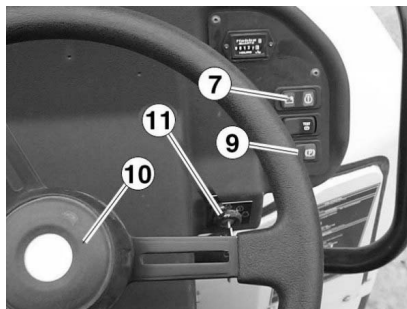

17. Turn ignition switch (11, Figure 4-11) to ON position, and verify that the following occurs:
 - a. Park Brake (P) switch indicator light (9, Figure 4-11) turns ON.
 - b. Indicator lights (7, Figure 4-11) turn ON.
18. Press horn button (10, Figure 4-11) to verify that horn is operational.
19. To confirm that engine will only start with the propulsion control in the STOP position, move propulsion control lever ← (14, Figure 4-9) in either direction away from the STOP position.
20. Make sure no personnel are close to the machine, with the brake applied, turn the ignition key (11, Figure 4-11) to the Start position. The engine should not start, verifying that the machine will not start with the propulsion control lever in a position other than the STOP position.
21. Return ignition switch (11, Figure 4-11) to the stop position.
22. Place the propulsion control lever ← (14, Figure 4-9) in the STOP (center) position.

STARTING MACHINE AND OTHER CHECKS/VERIFICATIONS

Starting procedure and checks and verifications while engine running.

NOTE: If any controls or devices do not function correctly, call for service.

1. Be sure water spray switch (3, Figure 4-12) is in the OFF (center) position.

Figure 4-12

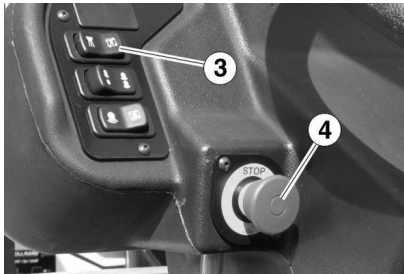

2. Position propulsion control (14, Figure 4-13) to the STOP position. Engine will not crank if control is out of "STOP" position.

Figure 4-13

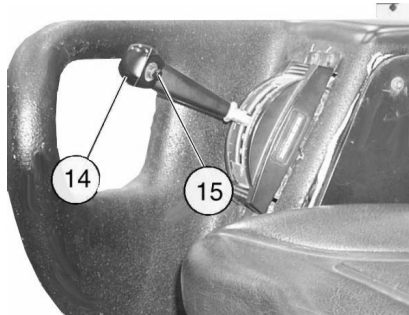

3. Position the engine throttle switch (13, Figure 4-14) to Low Idle. Engine will not crank in Hi Idle position.

Figure 4-14

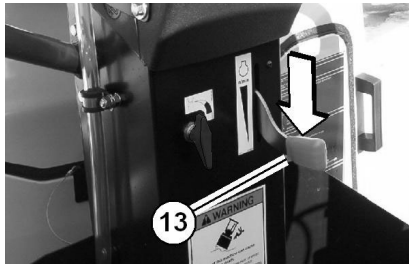

4. If applied, reset the emergency stop switch STOP (4, Figure 4-12) by pulling outward on the switch. Engine will not crank if emergency stop switch is depressed.

5. Be sure Park Brake switch (9, Figure 4-15) is in the "Applied" position.

NOTE: Engine will not crank if Park Brake is in "OFF" position.

Figure 4-15

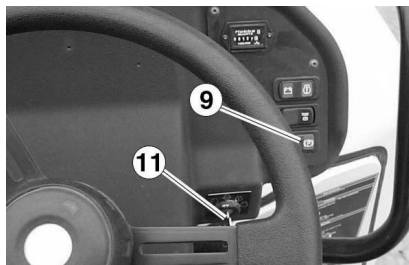

NOTICE

Starter may overheat if operated longer than 30 seconds. If the engine fails to start, allow the starter to cool 2 to 3 minutes before trying again.

If ambient temperature is below -5° C (23° F) and the engine is not warm, it will be necessary to use the glow plug. Turn ignition key to the preheat position for a period of from 5 to 20 seconds. Do not preheat continuously in excess of 20 seconds.

6. Turn ignition switch (11, Figure 4-15) to START position. Once engine starts, release switch immediately, and it will return to the ON position.

NOTE: Run engine for short time to warm up the engine and hydraulic systems, but do not run engine at idling speed in excess of 10 minutes.

7. Check for correct operation of steering system with engine running by turning steering wheel fully to left and then to right. The movement of the steering should be smooth and without hesitation. If not, notify appropriate personnel.
8. With engine running, release parking brake control (9, Figure 4-15) and ensure Brake Light goes out. Observe area around machine for personnel/obstructions. If the machine is equipped with a back-up alarm, move propulsion control (14, Figure 4-13) in reverse direction to check that alarm is operational. Alarm should sound even before machine begins movement. Return propulsion control to STOP position. If alarm is not operational or does not sound immediately, contact appropriate personnel.

9. Check for correct operation of brake systems by driving the machine in forward and reverse directions using propulsion control (14, Figure 4-13) to alternately accelerate and brake machine movement. Return propulsion control to STOP position. If brake system is questionable, contact appropriate personnel.

NOTE: Braking should be smooth and capable of bringing machine to a complete stop when propulsion control is placed in STOP position.

10. Apply parking switch (9, Figure 4-15).
11. Check for correct operation of the emergency stop. While the propulsion control (14, Figure 4-13) is in the STOP position, depress the red emergency stop knob STOP (4, Figure 4-16).

Figure 4-16



NOTE: The engine should immediately shut down and the parking brake light should illuminate indicating the brakes are applied. A restart of the machine will be required after performing the above. Also, the emergency stop switch must be reset by pulling outward on the knob.

OPERATING THE MACHINE

Operating Suggestions and Checks While Operating Machine.

1. Always sound horn before moving the machine in either direction to alert persons. Allow sufficient time for persons to move from vehicle's path before putting the machine into motion.
2. Monitor all warning lights. If instruments or lights indicate a fault or problem, contact appropriate personnel.
3. Monitor and ensure horn and optional back-up alarm function and that optional lights give additional illumination of the working area.
4. Monitor working area for obstacles and persons.
5. Always remove the ignition switch key and check that the parking brake is applied before leaving the operator station.
6. Always move the steering wheel slowly and monitor the steering action.

Moving the Machine (Propulsion Control)

1. Always check travel and work areas for personnel and obstructions.
2. If the articulation lock bar (1, Figure 4-17) is in the locked position, move it to the stowed position.
3. Place engine throttle control (13, Figure 4-18) to the Hi (Up) position.

Figure 4-17

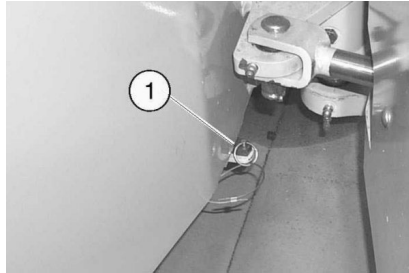

NOTE: Never use engine speed control to control the speed of travel.

Figure 4-18

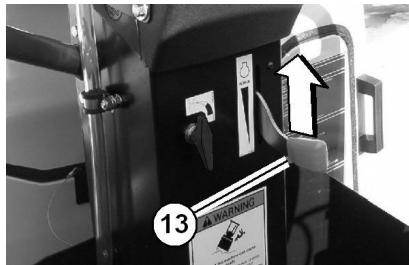

4. Release the parking brake by pushing inward on the left side of switch (9, Figure 4-19). Observe that the switch indicator light goes out.

Figure 4-19

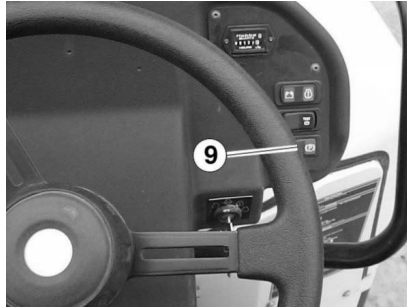

NOTE: Operator must be seated when Park Brake is released or engine will stop after approximately two seconds.

5. Slowly move propulsion control (14, Figure 4-20) to achieve desired direction and safe speed of travel as determined by the conditions. The further the control is moved from the STOP position the greater the speed in that direction.

Figure 4-20

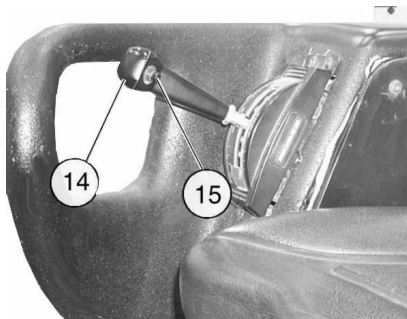

Using Vibration Controls: Operating the Machine Using Auto Vibration

NOTE: When Auto Vibration Mode is selected, vibration begins automatically when the machine travel speed reaches approximately ½ mph.

1. Position the water spray switch (3, Figure 4-21) at the desired setting for Manual, OFF, or Auto drum spray.
2. Press the right side of vibration switch (1, Figure 4-21) to select Auto Vibration.
3. Place the drum selector switch (2, Figure 4-21) to front drum vibration.
4. Move propulsion control (14, Figure 4-20) in the desired direction and safe speed of travel as determined by the conditions.

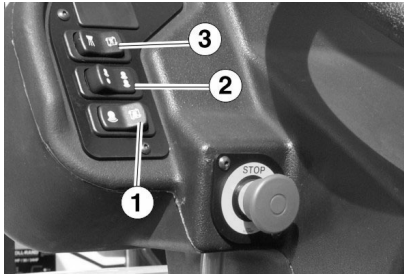
Figure 4-21

5. Place engine throttle control (13, Figure 4-22) to the Hi (Up) position.
6. Adjust water spray flow control (12, Figure 4-22) for the desired amount of spray on the drums.

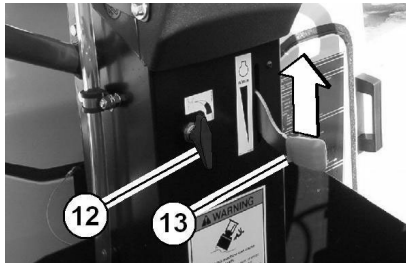
Figure 4-22

7. Press Vibration ON/OFF switch (15, Figure 4-23). If vibration does not begin when machine reaches $\frac{1}{2}$ mph., press the switch again.

Figure 4-23

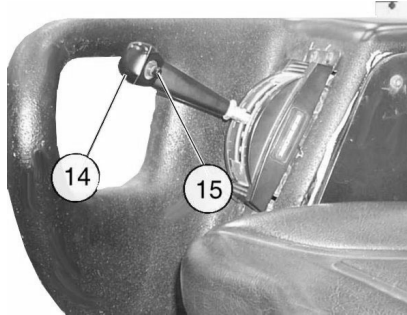

Using Vibration Controls: Operating the Machine Using Manual Vibration.

NOTICE

Asphalt mat damage.

With the engine running and the vibration switch on, the machine will vibrate.

DO NOT vibrate with the machine stationary.

1. Position the water spray switch (3, Figure 4-24) at the desired setting for Manual, OFF or Auto drum spray.
2. Press the right side of vibration switch (1, Figure 4-24) to select Auto Vibration.
3. Place the drum selector switch (2, Figure 4-24) to front drum vibration.

Figure 4-24

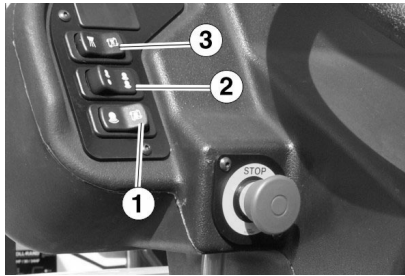

- 4. Place engine throttle control (13, Figure 4-25) to the Hi (Up) position.

Figure 4-25

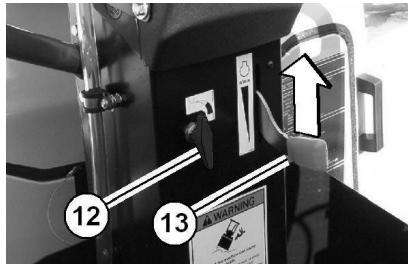

- 5. Move propulsion control (14, Figure 4-23) in the desired direction and safe speed of travel as determined by the conditions.
- 6. Adjust water spray flow control (12, Figure 4-25) for the desired amount of spray on the drums.

NOTE: Only switch vibration ON when machine is moving. Always switch vibration OFF before the machine comes to a halt. Never allow machine to vibrate when machine is stationary.

- 7. Once the travel of the machine is underway, the drum vibration can be selected by pressing Vibration ON/OFF switch (15, Figure 4-23).

PARKING, STOPPING AND SHUTTING DOWN THE MACHINE

Parking the Machine

1. To park the machine, move to firm, level ground. If circumstances require parking the machine on other than level ground, chock the drums.
2. To stop the machine upon reaching destination, use the following procedure.

Stopping the Machine

1. If drum vibration is active, press vibration ON/OFF switch (15, Figure 4-23) to stop vibration.
2. If water spray system is ON, move water spray switch (3, Figure 4-24) to the OFF (middle) position.
3. For normal stopping, move the propulsion control (14, Figure 4-23) slowly to the STOP position.
4. To ensure no machine movement occurs after stopping, apply parking brake by pressing on the right side of park brake switch (9, Figure 4-26) Indicator light will turn ON.

Figure 4-26

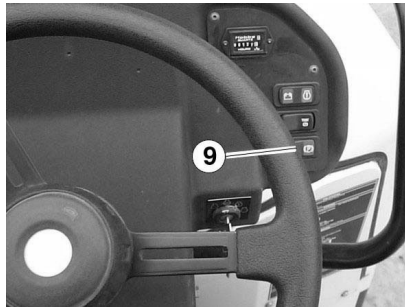

Shutting Down the Machine

1. Move engine throttle control (13, Figure 4-27) to the Low Idle (Down) position.
2. If the machine is to be serviced or transported, place the articulation locking bar (1, Figure 4-28) in the locked position.
3. Allow machine to idle for a few minutes before turning ignition switch to stop position. Remove ignition key.

Figure 4-27

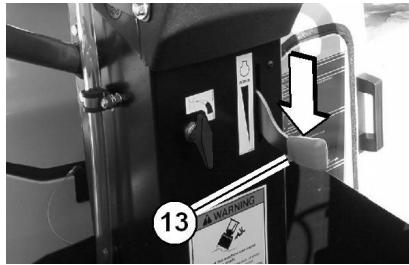
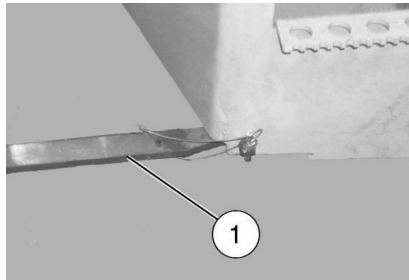

Figure 4-28



DAILY PRECAUTIONS AFTER WORK

Perform the following precautions each day after work in addition to the daily routine maintenance on the lubrication chart.

1. Fill fuel tank to prevent condensation problems.
2. Clean drum scrapers of accumulated material.
3. If available, lock all vandal protection devices on the machine.

MOUNTING AND DISMOUNTING OF ATTACHMENTS

NOTE: All optional equipment mounting and dismounting on this machine must only be undertaken by trained service personnel.

MOVEMENT OF MACHINE BETWEEN WORK SITES

Before driving machine on public roads, check with your supervisor for instructions and information in respect to traffic regulations regarding construction machinery.

NOTE: For more information on transporting, refer to Section 1, SAFETY.

Loading the Machine Under its Own Power (Drive On) for Transporting.

1. Choose level ground which will solidly support the vehicle.
2. Clean the trailer surface and loading ramps.
3. Before loading machine, chock the wheels of the trailer.
4. A signalman must assist the operator with any necessary warnings.
5. Approach the transporter loading ramps squarely to make sure machine does not drop off side of ramp.
6. Drive machine onto transporter.
7. Shut engine OFF, apply parking brake and lock all lockable compartments.

Securing the machine to the transporter (Tie-down).

1. After loading the machine on the transporter, ensure that articulation lock bar is in the locked position.
2. Shut down engine and remove ignition switch key.
3. Chock the drums.
4. Tie-down machine using a chain and tensioning device or other appropriate equipment to the tie-down points marked .
5. The driver of the transport must be aware of its total weight, load on the axles, and the overall dimensions of the machine.

TOWING THE MACHINE: MODELS DD-29 **WARNING**

Machine runaway condition could occur.

Always chock the drum and wheels of a disabled machine or hitch it to its towing vehicle to prevent accidental movement while preparing the machine for towing.

This is especially important if machine failure occurs on an incline.

To tow the machine, maximum 300 meters (984 feet), use the following procedure.

 **CAUTION**

Towing the compactor is limited to off the job site, onto the transporter, off the transporter, and into the shop.

The machine used to tow the compactor should be heavier than or equal to the weight of the compactor being towed.

Tow only on level ground or up a slight grade. Since the compactor braking system has been disabled, the towing machine is the only means of restraining the compactor while being towed.

Chock the disabled compactor whenever towing has stopped.

Refer to Transporting and Towing - Recommissioning in Section 1, SAFETY before transporting the compactor.

In the event of an engine problem or other malfunction, or if the engine will not start, it may become necessary to tow your compactor.

Towing the compactor requires bypassing the propulsion pump and releasing the spring-applied brakes. Procedures to do so are described below.

NOTE: The propulsion pump is designed with a bypass function that consists of two multi-function valve cartridges used to disengage the propulsion system.

The spring-applied brake will always be applied when the engine is running unless it is manually released.

1. Chock the drums.
2. Remove plugs (1, Figure 4-29) to access the brake release screws. Turn the release screws clockwise alternately, $\frac{1}{2}$ turn each, until the brake releases. Repeat this procedure for the remaining drum.
3. Open the hood and disengage the propulsion pump (1, Figure 4-30) by pressing down on buttons (2).

Figure 4-29

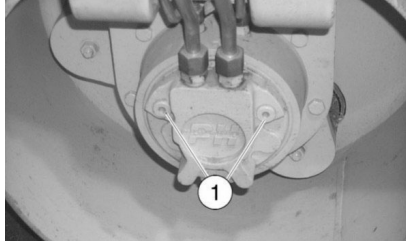
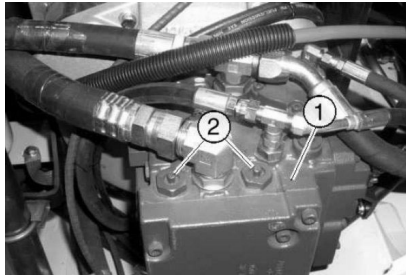

Figure 4-30



NOTICE

Use only appropriate drawbars for towing requirement.

Maximum towing speed is 2.5 km/h (1.5 mph) and maximum towing distance is 300 meters (984 feet).

4. Attach an appropriate towing vehicle using appropriate chains/drawbar which can be secured in position at the selected tow points on the machine. Remove the chocks.
5. Tow machine off site at a very slow speed for a short distance (maximum 300 meters [984 feet]).

6. Once the machine has reached its destination, engage the brakes on each drum by turning the screws counterclockwise.
7. Install plugs (1, Figure 4-29).
8. TURN ignition key to the "ON" position and verify the park brake switch is illuminated to indicate the brake has been applied.
9. Check the parking brake using the parking brake test switch procedures identified in Section 5 of these instructions.

NOTE: The propulsion pump will reengage when the engine starts.

TOWING THE MACHINE: MODELS DD-31HF/DD-38HF

WARNING

Machine runaway condition could occur.

Always chock the drum and wheels of a disabled machine or hitch it to its towing vehicle to prevent accidental movement while preparing the machine for towing.

This is especially important if machine failure occurs on an incline.

To tow the machine, maximum 300 meters (984 feet), use the following procedure.

CAUTION

Towing the compactor is limited to off the job site, onto the transporter, off the transporter, and into the shop.

The machine used to tow the compactor should be heavier than or equal to the weight of the compactor being towed.

Tow only on level ground or up a slight grade. Since the compactor braking system has been disabled, the towing machine is the only means of restraining the compactor while being towed.

Chock the disabled compactor whenever towing has stopped.

Refer to Transporting and Towing - Roading in Section 1, SAFETY before transporting the compactor.

In the event of an engine problem or other malfunction, or if the engine will not start, it may become necessary to tow your compactor.

Towing the compactor requires bypassing the propulsion pump and releasing the spring-applied brakes. Procedures to do so are described below.

NOTE: The propulsion pump is designed with a bypass function that consists of two multi-function valve cartridges used to disengage the propulsion system.

The spring-applied brake will always be applied when the engine is running unless it is manually released.

1. Chock the drums.
2. Remove plastic plug (1, Figure 4-31) from the center of each drum drive motor housing (2).

Figure 4-31

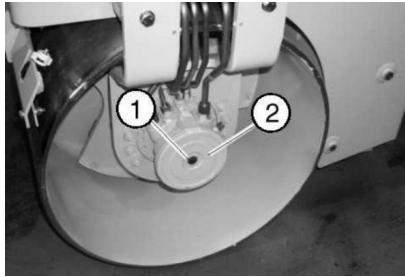

3. Disassemble the brake release bolts (1, Figure 4-32), nuts (2) and bars (3) from the drum support legs (4).
4. Assemble the nut and washer (2, Figure 4-32) onto the bolt (1) and place the bolt through the hole in the release bar (3).
5. Thread the bolt into the hole in the housing (2, Figure 4-32) until it bottoms out. Then, tighten the nut against the bar until the brake releases.

Figure 4-32

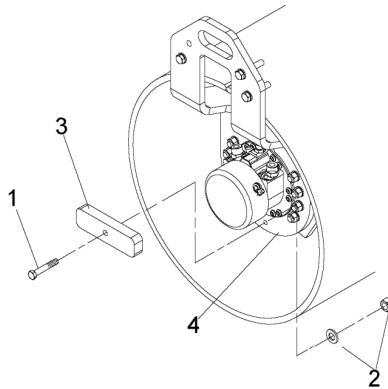

6. Open the hood and disengage the propulsion pump (1, Figure 4-33) by pressing down on buttons (2).

Figure 4-33

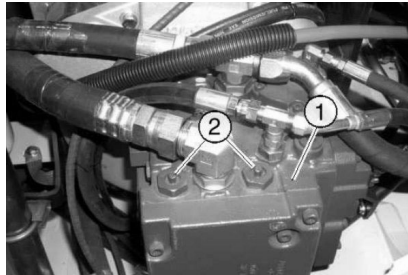

NOTICE

Use only appropriate drawbars for towing requirement.

Maximum towing speed is 2.5 km/h (1.5 mph) and maximum towing distance is 300 meters (984 feet).

7. Attach an appropriate towing vehicle using appropriate chains/drawbar which can be secured in position at the selected tow points on the machine. Remove the chocks.
8. Tow machine off site at a very slow speed for a short distance (maximum 300 meters [984 feet]).

9. Once the machine has reached its destination, engage the brakes on each drum by backing out the release bolts.
10. Assemble the brake release bolts, nuts and bars on the drum support legs as shown in Figure 4-32.
11. TURN ignition key to the "ON" position and verify the park brake switch is illuminated to indicate the brake has been applied.
12. Check the parking brake using the parking brake test switch procedures identified in Section 5 of these instructions

NOTE: The propulsion pump will reengage when the engine starts.

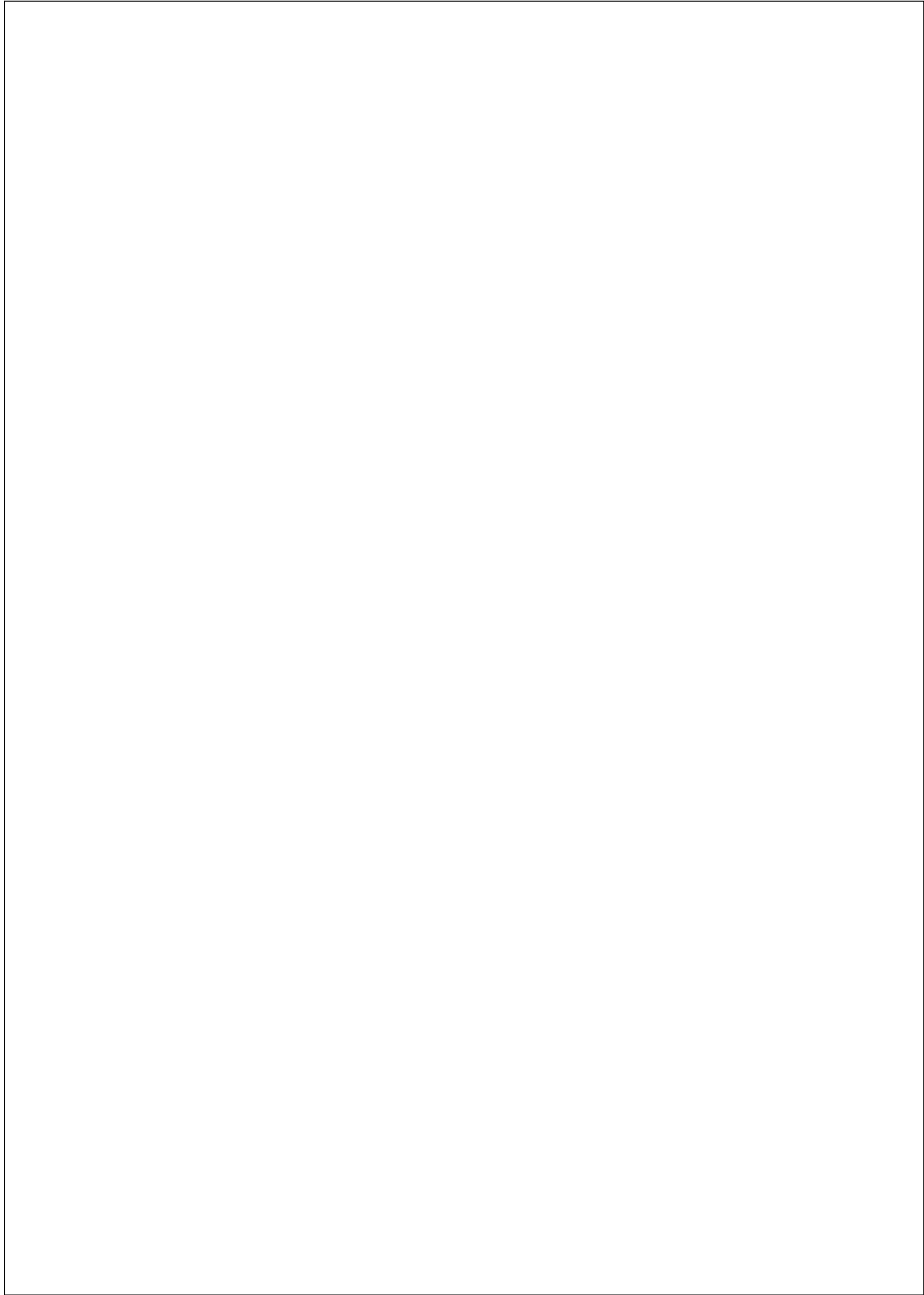



SECTION 5 - MAINTENANCE INSTRUCTIONS

MAINTENANCE INSTRUCTIONS

In order to ensure safe operation, optimum performance, and to protect your warranty, use only genuine manufacturer replacement parts.

WARNING

Unexpected machine motion or moving parts can cut or crush.

Install the articulation lock bar, apply the parking brake and shut down the engine before working on the machine.

WARNING

Improper maintenance can be hazardous.

Read and understand Section 1, SAFETY which contains safety precautions and guidelines before you perform any maintenance, service or repairs.

GENERAL MAINTENANCE INFORMATION

To prevent minor irregularities from developing into serious conditions, several other services or checks are recommended for the same intervals as the periodic lubrication. The purpose of these services or checks are to ensure the uninterrupted and safe operation of the machine by revealing the need for adjustment caused by normal wear.

Prior to conducting any maintenance work, ensure that the following instructions are observed:

1. Park the machine on firm level ground.
2. Shut down the engine and allow it to cool.
3. Disconnect battery power (as required) by removing the black ground terminal(s). Cover exposed terminals before working on the machine's electrical system. Certain troubleshooting procedures will require that battery terminals not be removed.
4. Following shutdown, allow hydraulic oil pressures to fall before working on hydraulic hose installations.
5. Thoroughly wash all fittings, caps, plugs, etc., with nonflammable, nontoxic cleaning solution before servicing, to prevent dirt from entering while performing the service.

Handling Fluids and Oil, Fuel Filters

1. When draining fluids, ensure that adequate sealable containers are available and that every care is taken to prevent spillage.
2. Always ensure that waste fluids are disposed of in an environmentally safe manner.
3. Always ensure that used filters are stored in secure containers and disposed of in an environmentally safe manner.

INITIAL BREAK-IN MAINTENANCE

New equipment requires the following initial one time break-in maintenance after 50 hours of operation. After this initial phase, the regular intervals listed in the following pages should be followed.

1. Change the engine oil and filter. Refer to Page 5-25 for procedure.

MAINTENANCE SCHEDULE

The maintenance chart (Table 5-1) shows those items that require regular service and the interval at which service should be performed. A regular service program should be geared to the items listed under each interval. These intervals are based on average operating conditions and manufacturer's recommendations. In the event of extremely severe, dusty or wet operating conditions, more frequent maintenance than specified may be necessary.

Table 5-1 : Maintenance Schedule

Function	Specification	Page
AS REQUIRED		
Check air cleaner connections and ducts for leaks	Refer to Section 9	Page 5-5
Clean/replace air cleaner elements-restrict. indicator		Page 5-9
Cleaning the machine		Page 5-11
Torque up any loose bolted connections		Page 5-12
Check/replace shock mounts torn or severely cracked		Page 5-13
DAILY (OR EVERY 10 HOURS)		
Check air cleaner connections and ducts for leaks	Refer to Section 9	Page 5-5
Check engine oil level	Dipstick marks	Page 5-13
Check engine coolant, clean radiator/oil cooler	Bottle/radiator	Page 5-14
Check air cleaner restriction indicator	Indicator	Page 5-15
Check fuel level	Level to gauge	Page 5-16

SECTION 5

MAINTENANCE INSTRUCTIONS

Function	Specification	Page
Check water tank level	Fill	Page 5-17
Check parking brake		Page 5-18
Clean water strainer		Page 5-19
WEEKLY (OR EVERY 50 HOURS)		
Check air cleaner connections and ducts for leaks	Refer to Section 9	Page 5-5
Check battery terminals and cables	Clean and grease	Page 5-20
Grease swivel (articulation) pin bearings	Refer to Section 8	Page 5-21
Grease steering cylinder pin bearings	Refer to Section 8	Page 5-21
Check hydraulic oil level	Level to gauge	Page 5-22
Check air cleaner system integrity		Page 5-23
Check eccentric oil level	Refer to Section 8	Page 5-23
Check engine coolant level		Page 5-24
SEMI-ANNUALLY (OR EVERY 250 HOURS)		
Change engine oil and filter	Refer to Section 8	Page 5-25
Change fuel filter and in-line filter	Refer to Section 8	Page 5-26
Purge lube carrier		Page 5-28
Change hydraulic oil filter	Refer to Section 8	Page 5-29
ANNUALLY (OR EVERY 1000 HOURS)		
Drain hydraulic oil, clean hydraulic oil tank	Refer to Section 8	Page 5-31
Drain and flush water tank and spray bars		Page 5-33
Change eccentric lube	Refer to section 8	Page 5-34
Drain flush radiator and replace coolant	Refer to Section 8	Page 5-35
Change air filter elements		Page 5-38
Clean fuel tank		Page 5-40

ROUTINE MAINTENANCE - AS REQUIRED

Check Air Cleaner Connections and Ducts for Leaks

Ensure that all the connections between the air cleaner and the engine are tight and sealed.

Checking and Removing the Air Cleaner Primary Element

Maintenance of the air cleaner is due only when the air cleaner restriction indicator light (1, Figure 5-1) is illuminated. This indicates that the air cleaner is plugged and requires attention.

Figure 5-1

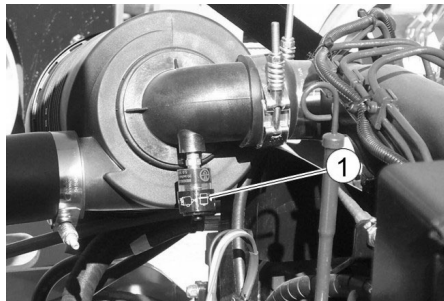

The air cleaner is a dry-type with two elements. A primary element that is replaceable, or can be cleaned, and a safety element that should only be replaced and never cleaned. The safety element should be replaced after every third primary element cleaning or change.

NOTE: Dust that gets by the air cleaner system can often be detected by looking for dust streaks on the air transfer tubing or just inside the intake manifold inlet.

CAUTION

Engine damage.

Raw, unfiltered air can cause engine damage.

Never service the air cleaner while the engine is running.

1. Open two clips (1, Figure 5-2) and remove air filter housing cover (2) to access the filter elements. Check vacuator valve (3) to see that it is not inverted, damaged or plugged. Clean inside housing cover (2) using a clean, damp cloth.

Figure 5-2

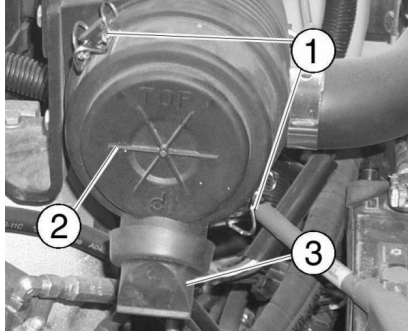

2. Gently remove primary filter element (1, Figure 5-3).

Figure 5-3

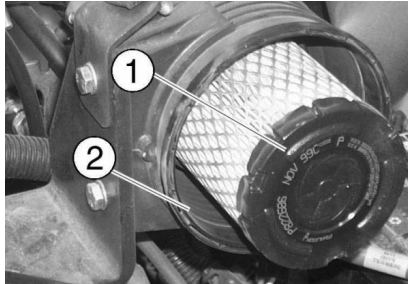

3. Ensure that safety element (1, Figure 5-4) is secure and clean the inside of the filter housing (2, Figure 5-3) with compressed air.

Figure 5-4

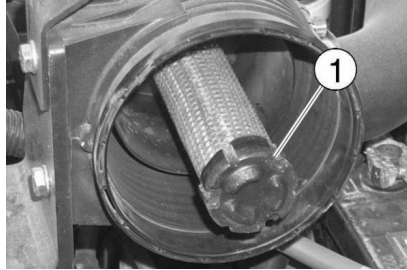

Clean the Primary Air Cleaner Element

WARNING

When using compressed air, water jets, or steam cleaning methods, ensure that appropriate protective clothing is worn to protect eyes and exposed parts of the body.

NOTICE

Excessive air pressure can damage the primary air element.

Pressure should not exceed 276 kPa bar (40 psi).

NOTE: No attempt should be made to clean the safety element. For maximum engine protection, replace the safety element every third primary element change or annually.

1. To clean the primary air cleaner element using the dry method, perform the following:
 - Carefully direct the compressed air, not to exceed 6.89 bar (100 psi), at an angle onto the inside surface of the primary air cleaner element (Figure 5-5).

Figure 5-5

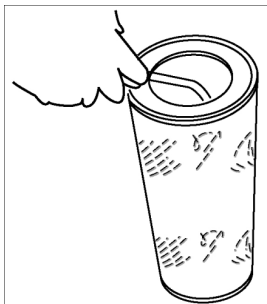

- Move air jet up and down the pleats until no additional dust is being removed. Be careful not to rupture the element pleats with the air nozzle.
 - Inspect for holes and tears by looking through the primary air cleaner element toward a bright light. Check for damaged gaskets or dented metal parts. **DO NOT REUSE DAMAGED AIR FILTER ELEMENTS.**
2. To clean the primary air cleaner element using the wet method, perform the following:

⚠ WARNING

Never use gasoline or solvents to clean the elements.

Gasoline or solvents are extremely flammable.

May cause serious injury or death.

- Remove the loose dirt from the primary filter element using a water hose.
- Soak the primary filter element in a non-sudsing detergent solution for at least 15 minutes and not more than 24 hours. Refer to Figure 5-6.

Figure 5-6

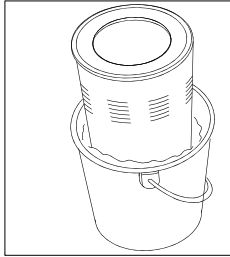

- Swish the primary filter element around in the solution to loosen dirt particles and put them into suspension in the solution.
- Rinse the primary filter element from the "clean" side to the "dirty" side with a gentle stream of water. Rinse from both sides if necessary.
- Dry the primary filter element before reusing. Circulate warm air at LESS than 71° C (160° F). DO NOT USE A LIGHT BULB TO DRY THE PRIMARY FILTER ELEMENT.
- Inspect for holes and tears by looking through the primary filter element toward a bright light. Check for damaged gaskets or dented metal parts. DO NOT REUSE DAMAGED FILTER ELEMENTS.
- Protect the filter from dust and damage during drying.

Replace the Air Cleaner Elements

1. Examine the new or cleaned primary air cleaner element for torn or damaged pleats, liners or gaskets or bent end covers.
2. The safety element (1, Figure 5-7) should be replaced at this time if:
 - Examination of the removed primary element reveals torn or perforated element.
 - Primary element has been replaced three times or 1 year duration.
 - If air cleaner restriction is present after servicing the primary element.

Figure 5-7

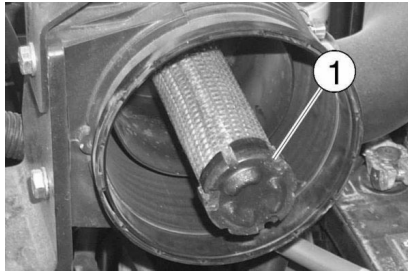

3. Clean the inside of the air cleaner housing before removing the safety element (1, Figure 5-7).
4. Pull the safety air cleaner element (1, Figure 5-7) out of the housing. Dispose of used element properly.
5. Carefully install the replacement safety element by pushing it straight into housing.
6. Carefully install the cleaned or replacement primary element (1, Figure 5-8).
7. Install air cleaner cover (2, Figure 5-9) and secure with clips (1). Ensure all clips are tight.
8. Inspect all air intake piping and joints between air cleaner and engine air inlet to ensure no dusty air can enter.

Figure 5-8

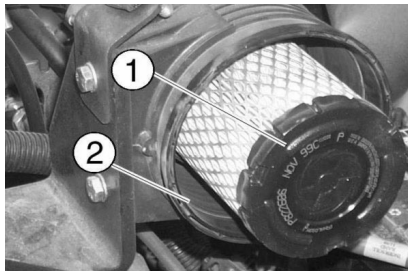
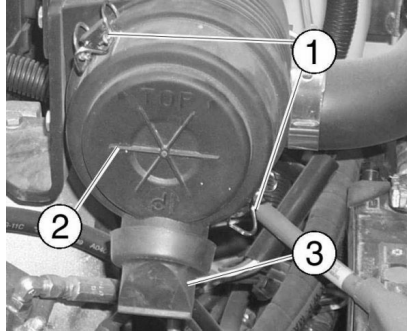

Figure 5-9



Clean/Wash/Lubricate the Machine

Anytime a machine or component is washed down with a hose or high pressure wash system, there is the possibility that water or other contaminants can be forced into bearings, seals, electrical panels, or other components. Protect or avoid directly spraying these components in the engine compartment or elsewhere on the unit.

Ensure that after cleaning the machine is completely lubricated immediately, especially in the areas that water or contaminants may have entered. These areas include the articulation and swivel joint pins and bushings, console bearings, and linkages. Refer to Section 8, FUEL AND LUBRICANT SPECIFICATIONS for complete lubrication specification information.

The complete machine must be given a weekly cleaning. Daily cleaning will be required if material is adhering to the drum.

NOTICE

Protect all electrical components and control panels against entry of water or steam when using high pressure cleaning methods.

Do not use harsh cleansers which may damage painted surfaces.

After washing, run the engine until it is warm. This will help to dry out engine components and electrical connections.

Lubricate all grease fittings immediately following the cleaning of the machine.

Prior to cleaning:

1. Remove any material jammed between the scraper (1, Figure 5-10) and drum (2).

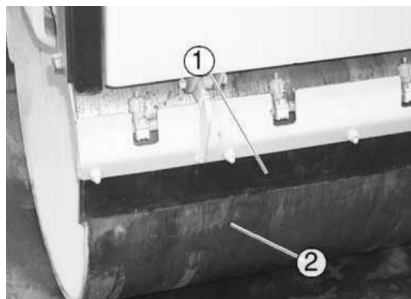
Figure 5-10

2. Clean the vacuator valve (3, Figure 5-9) and inspect the rubber for cracks. Replace as required.

After cleaning:

1. Remove all material added for protection from water entry.
2. Grease fittings immediately with the exception of the optional self lubricating bearings.
3. Check for defects in the air cleaner ducts and correct as required.
4. Check air intake for accumulation of debris that could restrict air flow and clear the air intake.
5. Check air cleaner mounting hardware for security and correct as required.
6. Check all hoses for cracks, chafing or deterioration and replace at the first sign of probable failure.

Torque Loose Bolted Connections

1. Properly torque all loose nuts or bolts found during the daily inspection. Refer to Section 9, TORQUE SPECIFICATIONS.
2. Replace self locking nuts if they have been loosened.

Check all Shock Mounts

1. Check all shock mounts periodically for looseness or deterioration. Item 1 in Figure 5-11 shows the Vibration motor side shock mounts.

Figure 5-11

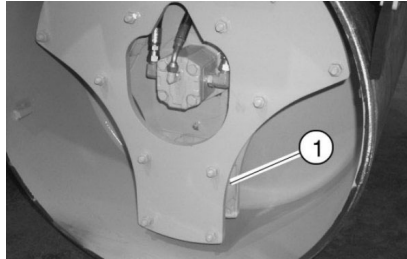

2. Replace shock mounts (one at a time) that have torn or excessively cracked rubber. Torque all capscrews and nuts as necessary.

10 HOUR OR DAILY ROUTINE MAINTENANCE

Check Engine Oil Level

1. Park machine on stable, level surface and shut down engine.
2. Pull out dipstick (1, Figure 5-12) and wipe it clean with a lint-free, dry cloth. Push dipstick back into engine.

Figure 5-12

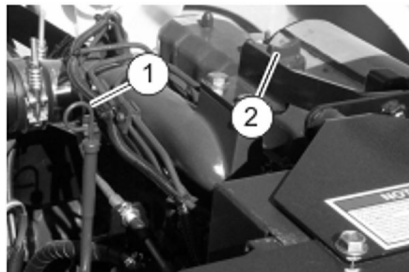

3. Pull out the dipstick again. The oil level must be between the full - top mark and low-bottom mark.
4. If oil level is low, add SAE 15W-40 oil through the fill area (2, Figure 5-12) to bring oil to the proper level.
5. Check oil level again after engine has run for about 1 minute. Add oil if necessary.

Check Engine Coolant Level, Clean Radiator and Oil Cooler **WARNING**

Injury can occur when removing the radiator cap.

Steam or fluid escaping from the radiator can burn. Inhibitor contains alkali, avoid contact with skin and eyes. May cause serious injury or death.

Always shut down the engine and allow it to cool down before removing the radiator cap. Remove cap slowly to relieve pressure. Avoid contact with steam or escaping fluid.

1. Check engine coolant level by observing the level in the coolant recovery bottle (1, Figure 5-13). Coolant level should be at the "CPLD FILL MIN" mark. If required, add a 50-50 mixture of coolant and water to bring coolant to the proper level.

Coolant Level must be maintained. Air will enter engine coolant system if no coolant is present in the bottle.

2. Check for signs of clogging of exposed cooling fins on the radiator (1, Figure 5-14) and oil cooler (2).
3. If clogging is dried on dirt, use a suitable brush to remove from cooling fins. If dry dust is present, use compressed air to clean.

 **WARNING**

When using compressed air, water jets or steam cleaning methods, ensure that appropriate protective clothing is worn to protect eyes and exposed parts of the body.

4. In case of severe clogging due to fluid leaks, apply diesel fuel or a commercial cleaning detergent; let it soak in, and then wash off with a water jet.

Figure 5-13



Figure 5-14

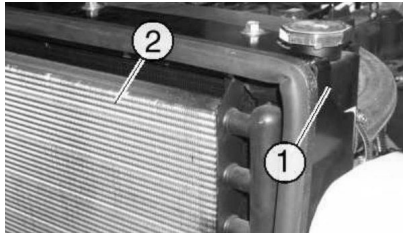

Check Air Cleaner

Check the air cleaner element at this interval. Refer to “Checking and Removing the Air Cleaner Primary Element” on Page 5-5.

Check Air Cleaner Restriction Indicator

1. Check the air cleaner restriction indicator (1, Figure 5-15).
2. If indicator is red, the air cleaner element(s) are plugged and need replaced or cleaned. To replace or clean elements, refer to Page 5-9 for details.

Figure 5-15

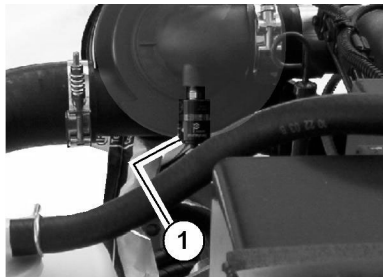

Check Fuel Level**NOTICE**

Never allow tank to completely empty, otherwise, the entire fuel system will require bleeding. Fuel tank should always be filled at the end of the shift to prevent condensation.

1. Check fuel level gauge (1, Figure 5-16).

Figure 5-16

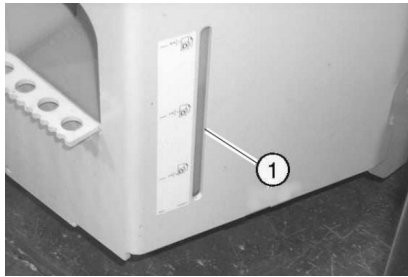
**⚠ WARNING**

Fuel is flammable. May cause severe injury or death.

Shut down the engine, extinguish all open flames and do not smoke while filling the tank.

Always wipe up any spilled fuel.

2. If fuel is required, remove fuel cap (1, Figure 5-17) and add No. 2 diesel to the tank.

Figure 5-17

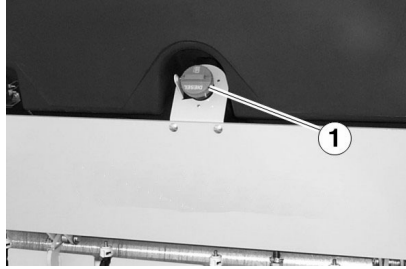

Check Water Tank Level

1. Check the water level using sight gauge (1, Figure 5-18).

Figure 5-18

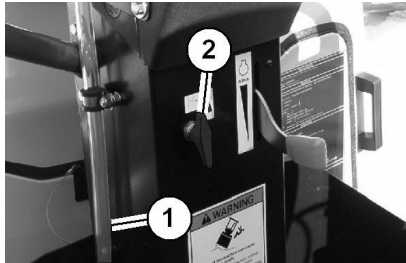

NOTE: During normal operation, maintain the tanks full of clean water at all times. Do not allow the tanks to become empty for any reason other than for cleaning.

The water supply for the water spray system is held in tank (1, Figure 5-19). The water tank also functions as the operator platform.

2. If water level is low, remove the fill cap (2, Figure 5-19).
3. Fill tank with clean water.
4. Replace fill cap.

Figure 5-19

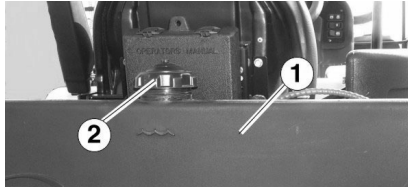

Check Parking Brake

1. With the engine running, press park brake switch (9, Figure 5-20) to activate the park brake. The switch indicator light turns ON.

Figure 5-20

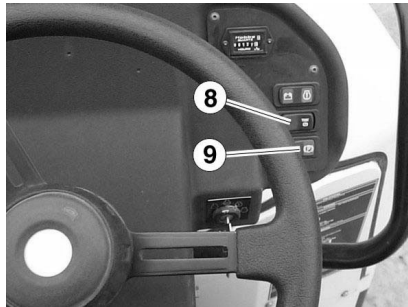

2. Press and hold park brake test switch (8, Figure 5-20) and move propulsion control (14, Figure 5-21) towards the Forward position to attempt machine movement. If the parking brake system is functioning, the machine will not move. If machine moves, contact service personnel and do not operate machine.

Figure 5-21

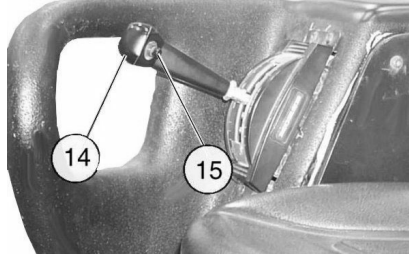

Clean Water Strainer

Check the water spray system strainer (1, Figure 5-22) clean as necessary at this interval.

1. Park the machine on a level surface and turn OFF the engine. Turn OFF water flow control (2, Figure 5-18).
2. Unthread clear plastic bowl (2, Figure 5-22) and remove strainer (1).

Figure 5-22

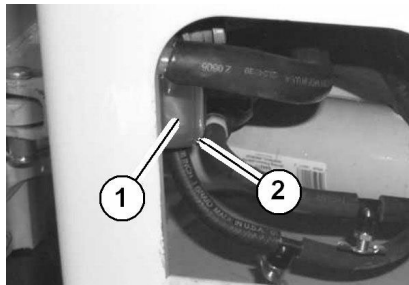

3. Rinse the strainer and bowl in clean water. If necessary use a soft bristle brush for hard to remove deposits.
4. Be sure gasket is in place and reassemble the strainer and bowl.

50 HOUR OR WEEKLY ROUTINE MAINTENANCE

Check Battery, Clean and Grease Terminals

WARNING

Batteries contain an acid and can cause injury.

Battery fumes can ignite and explode. Skin and eye contact with the battery fluid can cause injury.

Do not smoke when observing battery fluid level. Avoid skin and eye contact with the battery fluid. If contact occurs, flush area immediately with water.

The standard battery (1, Figure 5-23) supplied with the DD-29 and DD-31HF/38HF Vibratory Compactors is a maintenance-free type battery.

Figure 5-23

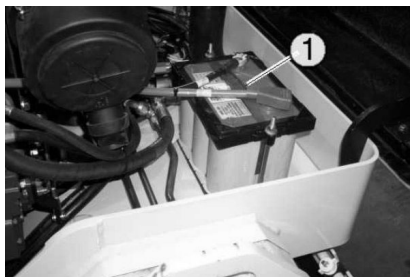

This battery requires only the following maintenance:

- Clean terminals.
- Keep battery connections tight.
- Apply small amount of grease to terminals to prevent corrosion.

Grease Articulation Pin Bearings

1. Clean the articulation pin grease fittings (1, Figure 5-24).
2. Apply MPG-EP2 grease to each fitting with a grease gun as needed.

Figure 5-24

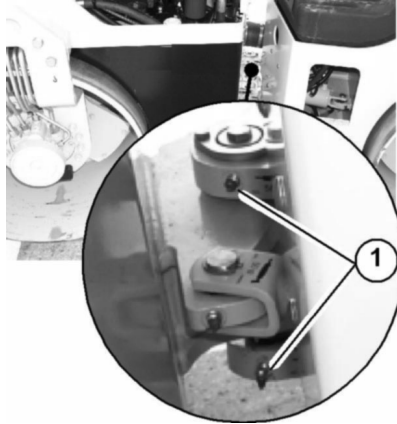

Grease Steering Cylinder Pin Bearings

1. Clean the grease fittings (1, Figure 5-25) on the steering cylinder.

Figure 5-25

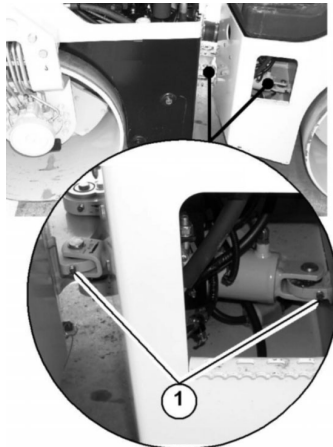

2. Apply three shots of MPG-EP2 grease to each fitting with a grease gun as needed.

Check Hydraulic Oil Level**NOTICE**

Dirt in the hydraulic system will lead to premature component failure.

A clean, contaminant-free system is extremely important to the machine's proper function.

Take extra care when working around or on the hydraulic system to ensure its complete cleanliness.

1. Check hydraulic oil level at gauge (1, Figure 5-26). If required add fresh, clean, anti-wear, ISO Grade 46 hydraulic oil through fill area (1, Figure 5-27). Be sure to install fill plug.

Figure 5-26

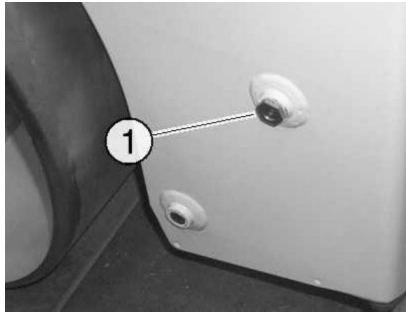
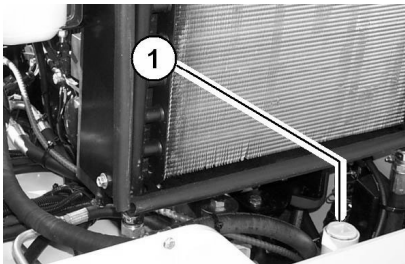

Figure 5-27



Check Air Cleaner System Integrity and Filter Elements

To verify that the air cleaner system is functioning properly, refer to Page 5-5 through Page 5-9 for checks and procedures.

Check Eccentric Oil Level

1. Park the machine on a level surface with the drum indexes (1, Figure 5-28) in the Twelve o'clock and Six o'clock positions. This places the check plug (2) and fill plug (3) in the proper orientation.

Figure 5-28

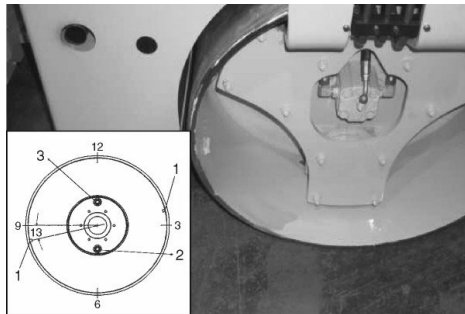

2. Remove check plug (2, Figure 5-28). Oil should be level with the bottom of the hole.
3. If additional oil is required, remove fill plug (3, Figure 5-28) and add Synthetic Component Lubricant oil as required until oil flows from the check hole.
4. Install plugs and wipe up excess oil.

Check Engine Coolant Level

1. Check engine coolant level by observing the level in the coolant recovery bottle (1, Figure 5-29). Coolant level should be between the "FULL" and "LOW" marks on the bottle. If required, add a 50-50 mixture of coolant and water to bring coolant to the proper level.

Figure 5-29



250 HOUR OR QUARTERLY ROUTINE MAINTENANCE

WARNING

Hot oil or components can burn.

Oil must be at normal operating temperature when draining.

Avoid contact with hot oil or components.

Do not allow oil to drain into the ground. Dispose of properly.

Change Engine Oil and Filter

1. Run the engine to ensure oil is at operating temperature. Position the machine on a stable, level surface and shut OFF engine.
2. Place container with a capacity of at least 12 quarts (11.4 liters) under the engine drain point, remove the plastic plug, and drain plug (1, Figure 5-30).

Figure 5-30

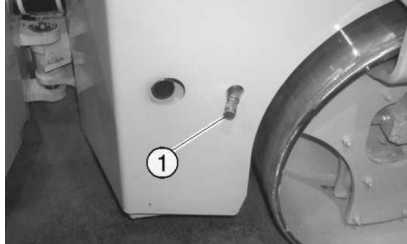

3. Clean the area around the head of oil filter (1, Figure 5-31) and remove the filter using a filter wrench. Catch any escaping oil in a container.

Figure 5-31

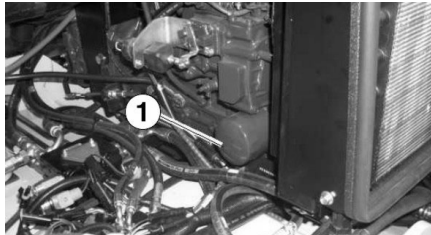

4. Dispose of used oil in accordance with local regulations.
5. Wipe the sealing face of the filter head and make sure the used seal is removed before installing the new filter.
6. Before installing the new filter, apply a film of oil to the filter gasket.
7. Install the filter and hand tighten.

8. Clean drain plug (1, Figure 5-30) and install.
9. Refill crankcase with 10 quarts (9.5 L) of 15W-40 motor oil through the fill area (2, Figure 5-32).

Figure 5-32

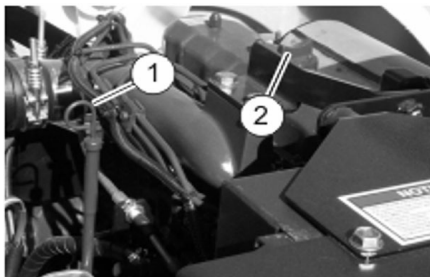

Change Engine Fuel Filter Element and In-Line Fuel Filter

WARNING

Fuel is flammable. May cause severe injury or death.

Shut down the engine, extinguish all open flames and do not smoke while filling the tank.

Always wipe up any spilled fuel.

1. Position the machine on a stable, level surface and shut OFF engine.
2. Place a container under the fuel filter (1, Figure 5-33) to capture any escaping fuel and remove the filter using a filter wrench.

Figure 5-33

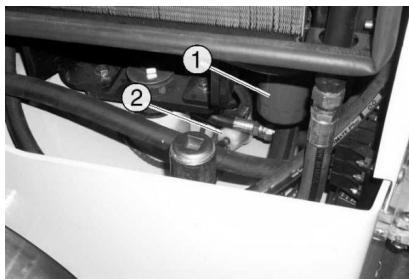

3. Wipe fuel filter head clean and remove all of the old gasket material from the filter head.
4. Lightly coat the gasket of the new fuel filter with diesel fuel, fill the filter with No. 2 diesel, and install it on the filter head. Hand tighten the filter.
5. Loosen hose clamps and remove in-line fuel filter (2, Figure 5-33). Install the new in-line filter and tighten the hose clamps.

NOTE: Air bleeding of the fuel system is required when ever the fuel filters have been removed from the machine.

6. Loosen vent plugs (1, Figure 5-34) a few turns. Turn the ignition key to the ON position to activate the electric fuel pump.

Figure 5-34

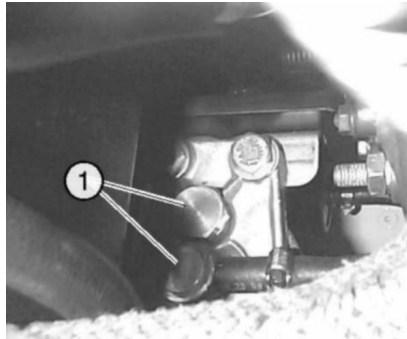

7. Allow air to escape until bubbles no longer appear. Tighten the vent plugs. Return the ignition key to the STOP position.
8. Open the air vent cock (1, Figure 5-35). Turn the ignition key to the ON position to activate the electric fuel pump.

Figure 5-35

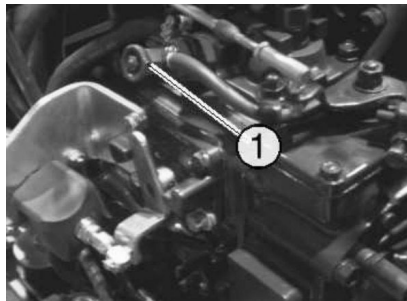

9. Allow air to escape until bubbles no longer appear. Close air vent cock (1, Figure 5-35) and return the ignition key to the STOP position.
10. Wipe up any fuel that has escaped and check for leaks.

Purge Lube Carrier

1. Park the machine on a level surface.
2. Clean the area around the protective cap (1, Figure 5-36) on the grease fitting of each drum.

Figure 5-36

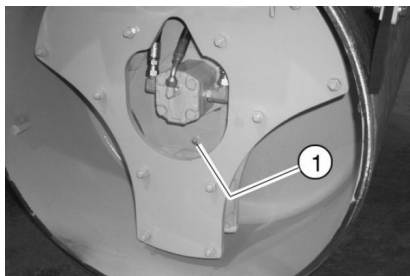

3. Remove the caps and apply MPG-EP2 grease to the grease fitting as required.
4. Wipe off excess grease and install protective caps.

Change Hydraulic Oil Filter **WARNING**

Hot oil or components can burn.

Oil must be at normal operating temperature when draining.

Avoid contact with hot oil or components.

Do not allow oil to drain into the ground.

 **WARNING**

Hot exhaust pipe can cause serious burns.

Avoid contact with exhaust pipe.

NOTICE

Dirt in the hydraulic system will lead to premature component failure.

A clean, contaminant-free system is extremely important to the machine's proper function.

Take extra care when working around or on the hydraulic system to ensure its complete cleanliness.

1. Remove hydraulic filter (1, Figure 5-37). Dispose of the used filter in accordance with local guidelines.

Figure 5-37

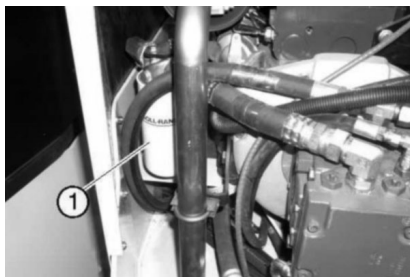

2. Clean the filter head using a clean, lint-free rag. Be sure that all of the old gasket material is removed.
3. Fill the new hydraulic filter with fresh, clean, hydraulic oil. Refer to Section 8, FUEL AND LUBRICANT SPECIFICATIONS for oil details.
4. Apply a film of hydraulic oil to the gasket of the new filter and install filter onto the filter head until gasket makes contact with the filter head. Tighten an additional one-half turn.
5. Check the hydraulic tank level. If low, fill the hydraulic tank with fresh, clean, hydraulic oil filtered through a 10 micron filter. Refer to Section 8, FUEL AND LUBRICANT SPECIFICATIONS for oil details.
6. Start the machine and check for leaks.

1000 HOUR OR ANNUAL ROUTINE MAINTENANCE**Drain, Clean and Fill Hydraulic Oil Tank** **WARNING**

Hot oil or components can burn.

Oil must be at normal operating temperature when draining.

Avoid contact with hot oil or components.

Do not allow oil to drain into the ground.

NOTICE

Dirt in the hydraulic system will lead to premature component failure.

A clean, contaminant-free system is extremely important to the machine's proper function.

Take extra care when working around or on the hydraulic system to ensure its complete cleanliness.

Drain hydraulic tank as follows:

1. Position the machine on stable level surface, shutdown the engine and chock the drums.
2. Place a container with a capacity of at least 22.7 gallons (86 liters) under hydraulic tank drain point (1, Figure 5-38).

Figure 5-38

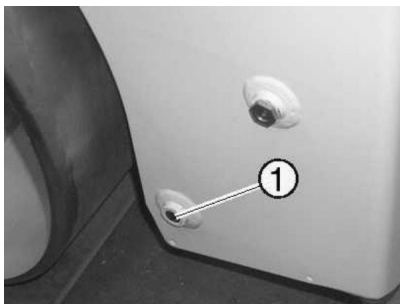

3. Remove drain plug (1, Figure 5-38) and fill plug (1, Figure 5-39) and drain the hydraulic tank. Dispose of used hydraulic oil in accordance with local guidelines.

Figure 5-39

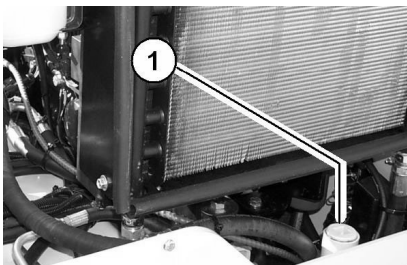

WARNING

Hot exhaust pipe can cause serious burns.

Avoid contact with exhaust pipe.

4. Fill the hydraulic tank with fresh, clean, hydraulic oil filtered through a 10 micron filter. Refer to Section 8, FUEL AND LUBRICANT SPECIFICATIONS for oil details.
5. Start the machine and check for leaks.

Drain and Flush Water Tank and Spray Bars

1. Remove the drain plug (1, Figure 5-40) and drain the tank.

Figure 5-40

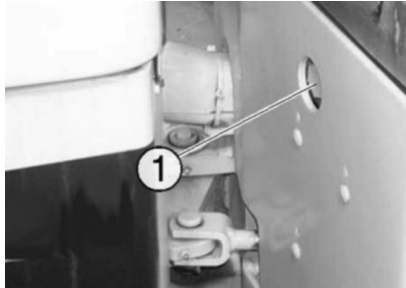

2. Remove the plugs (1, Figure 5-41) from each end of the spray bars flush out any accumulated sediment.
3. Disassemble each of the spray nozzles (2, Figure 5-41). Clean each with a wire brush and reassemble.

Figure 5-41

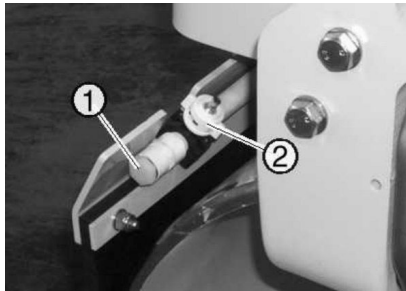

4. Remove water tank fill cap (2, Figure 5-42) from tank (1).

Figure 5-42

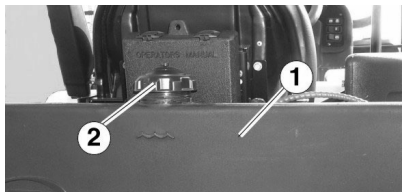

5. Wash the inside of the tank with warm soapy water and rinse with clear water.

6. Install plugs (1, Figure 5-43) in each end of the spray bars.
7. Install drain plug (1, Figure 5-43) in the tank.
8. If machine is going back into service, fill tank with clean water, and install cap (2, Figure 5-42).

Change Eccentric Lube

The eccentric lube oil in each drum must be changed at this interval.

⚠ WARNING

The oil must be at operating temperature for draining.

Use care, hot oil and components can burn.

1. Run the machine until oil is at operating temperature. Position the machine on a level surface with the drum indexes (1, Figure 5-43) and drain plug (2) oriented as shown.

Figure 5-43

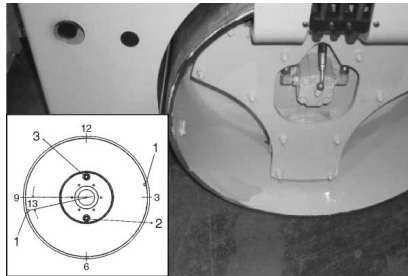

2. Place a drain pan under the drain point and remove plugs (2 and 3, Figure 5-43).

3. Reposition the machine so the drain and fill points (2 and 3, Figure 5-44) are oriented as shown.

Figure 5-44

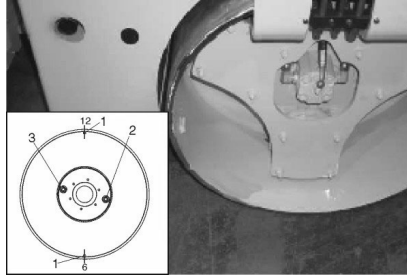

4. Pour Synthetic Component Lubricant oil into fill hole (3, Figure 5-44) until oil flows out drain hole (2).
5. Install plugs and wipe up excess oil.
6. Repeat steps 2 through 5 for the other drum.

Drain and Flush Radiator, Replace Engine Coolant



Injury can occur when removing the radiator cap.

Steam or fluid escaping from the radiator can burn. Inhibitor contains alkali, avoid contact with skin and eyes.

Always shut down the engine and allow to cool down before removing radiator cap. Remove cap slowly to relieve pressure. Avoid contact with steam or escaping fluid.

The coolant system of any vehicle should be drained and flushed out at least once a year. Unless coolant has a corrosion preventive in it, rust and scale will eventually clog up the system. Any effective, commercial flushing agent should be used at least once or twice a year to ensure against buildup.

NOTE: Remove the radiator cap (1, Figure 5-45) when draining the system, to ensure proper draining.

Figure 5-45

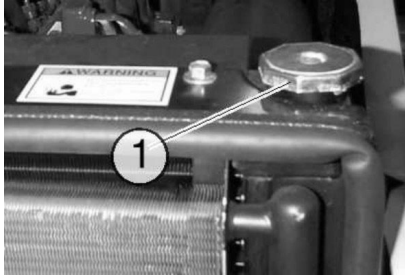

1. Place a container capable of holding at least 8 quarts (7.6 liters) of fluid under the radiator drain petcock (1, Figure 5-46). Open the petcock and drain the coolant from the radiator.

Figure 5-46

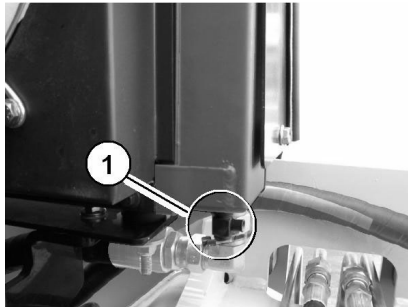

2. Place a container under the drain valve (1, Figure 5-47) on the engine. Open the valve and drain the coolant from the engine.

Figure 5-47

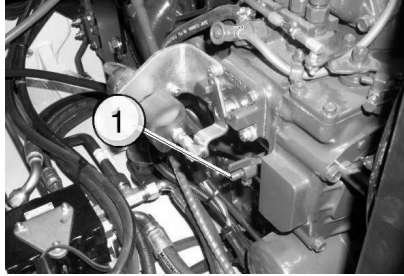

3. Check for damaged hoses and loose or damaged hose clamps. Replace as required. Check radiator for leaks, damage and buildup of dirt. Clean and repair as required.
4. Clean the cooling system using a commercial radiator flushing product. Follow the manufacturer's recommendations.
5. After cleaning and flushing operations are completed, close the drain valve (1, Figure 5-47) and petcock (1, Figure 5-46).

NOTICE

To prevent air locks, the system must be filled properly. Air must be vented from coolant passages during the fill operation.

NOTE: A mixture of ethylene glycol antifreeze and water is recommended to refill the radiator. Refer to the engine manual for the manufacturer's recommendation for proper ratio of antifreeze to water mixture. The addition of a separate lubricant and corrosion inhibitor will guard against internal corrosion and freezing.

6. Refill the coolant system.
7. Drain and clean overflow bottle (1, Figure 5-48). Refill the overflow bottle with a 50-50 mixture of antifreeze and water. Fill coolant bottle to "COLD FILL MIN" mark on the bottle.

Coolant Level must be maintained. Air will enter engine coolant system if no coolant is present in the bottle.

Figure 5-48

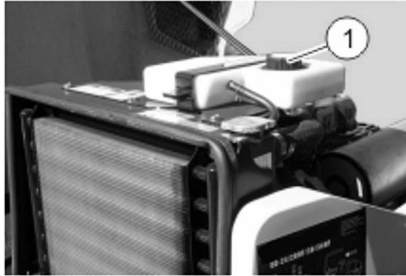

8. Install radiator cap (1, Figure 5-45) and cap on coolant recovery bottle. Operate engine until it reaches operating temperature. Check for any leaks.

Change Air Filter Elements

NOTE: Dust that gets by the air cleaner system can often be detected by looking for dust streaks on the air transfer tubing or just inside the intake manifold inlet.

The air filter elements must be changed at this interval.

⚠ WARNING

Engine damage.

Raw, unfiltered air can cause engine damage.

Never service the air cleaner while the engine is running.

1. Open two clips (1, Figure 5-49) and remove air filter housing cover (2) to access the filter elements. Check vacuator valve (3) to see that it is not inverted, damaged or plugged. Clean inside housing cover (2) using a clean, damp cloth.

Figure 5-49

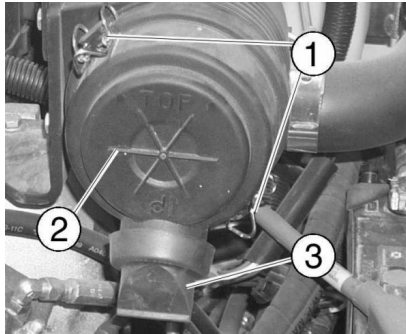

2. Gently remove primary filter element (1, Figure 5-50).

Figure 5-50

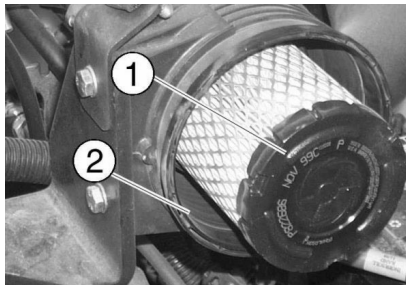

3. Ensure that safety element (1, Figure 5-51) is secure and clean the inside of the filter housing (2, Figure 5-50) with compressed air.

Figure 5-51

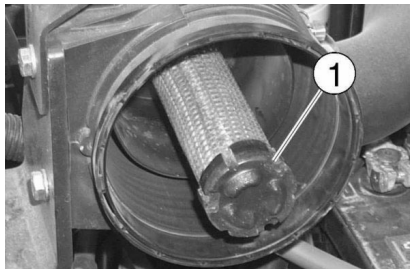

4. Inspect the new elements for tears or damaged pleats, bent end covers on liners and gaskets.
5. Carefully install the new safety element (1, Figure 5-51) by pushing it straight into housing.
6. Install new primary element (1, Figure 5-50).
7. Install filter housing cover (2, Figure 5-49) and secure with two clips (1).
8. Inspect all air intake piping and joints between the air cleaner and the engine air inlet to ensure that unfiltered air cannot enter the system.
9. Ensure that all clamps are tight.

Clean Fuel Tank

⚠ WARNING

Fuel is flammable. May cause severe injury or death.

Shut down the engine, extinguish all open flames and do not smoke while draining or refilling the tank.

Always wipe up any spilled fuel.

1. Park the machine on a level surface. Shutdown the engine.

2. Place a container with a large enough capacity to hold the contents of the fuel tank under the drain point (1, Figure 5-52). Full tank capacity is approximately 18 gallons (68.1 liters).

Figure 5-52

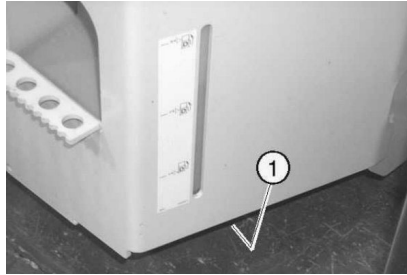

NOTICE

Do not reuse the fuel that has been drained from the fuel tank.

Always refill with fresh diesel fuel.

Discard drained diesel fuel in accordance with local guidelines.

3. Remove the drain plug and drain the fuel tank. Discard drained diesel fuel.
4. Rinse the tank with fresh clean diesel fuel.
5. Install the drain plug and refill the tank with fresh No. 2 diesel fuel.

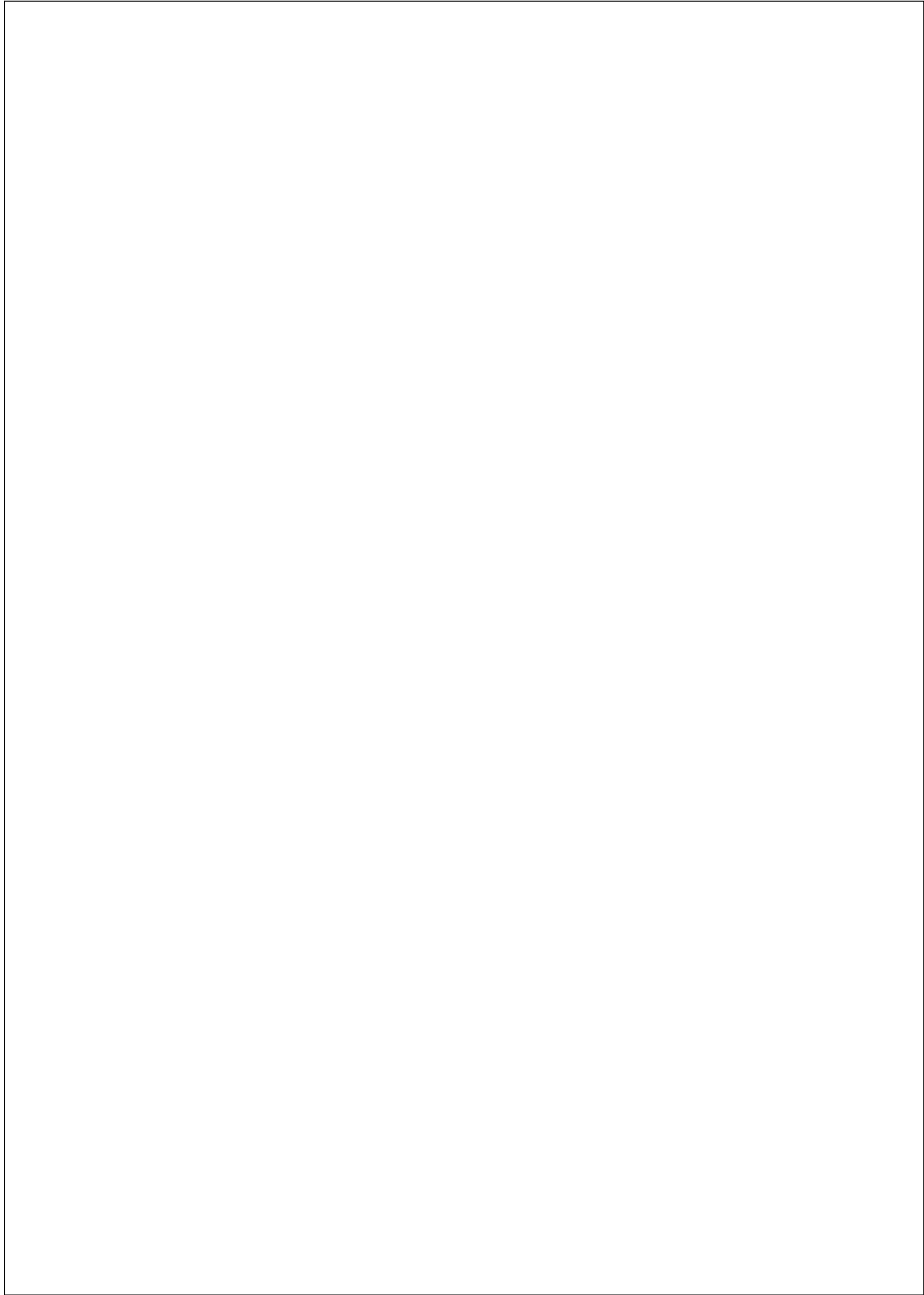



SECTION 6 - TROUBLESHOOTING

TROUBLESHOOTING



When carrying out trouble shooting procedures, it is important to strictly observe the safety precautions and guidelines in Section 1, SAFETY of this manual.

Improper operation and maintenance is the most frequent cause of machinery failures and problems. In the event of a failure, it is recommended to read through this manual.

If you are unable to determine the cause of the problem or are unable to find a solution when following the troubleshooting chart below, contact your local service office.

The troubleshooting chart is limited to machine control operational problems which will guide the operator to rectifying the cause of the failure.

Figure 6-1

				FUSE	FUNCTION
START F1 10 amp RELAY	VIB. SOLS. F2 10 amp POWER RELAY COIL	E-STOP: BRK& SHUNT SOLS. F3 10 amp FUEL PUMP 2-SEC TIMER/FUEL SHUTOFF	HORN, INDIC. LAMPS F4 10 amp	F1	Start Relay
				F2	Vibration Solenoids Power Relay Coil
				F3	Emergency Stop Brake and Shunt Solenoids Fuel Pump 2 Second Timer/Fuel Shut-off
				F4	Horn Indicator Lamps
WATER PUMP, F5 15 amp	WORK LIGHTS, F6 10 amp OPTION	BACK-UP ALARM, F7 10 amp OPTION	BEACON, F8 10 amp OPTION	F5	Water Pump
				F6	Work Lights Option
				F7	Back-up Alarm Option
				F8	Beacon Option
TURN/ STOP LIGHT, F9 10 amp OPTION	GAUGES F10 10 amp OPTION	AUDIBLE ALARM F11 10 amp OPTION	F12	F9	Turn/Stop Lights Option
				F10	Optional Gauges
				F11	Audible Alarm Option

PRE-START CHECK

Prior to attempting to start your compactor refer to the Checklist decal located in the operator area of the compactor. Failure to follow directions listed on this Checklist will not allow you to start the compactor. The Checklist is included in Section 1, SAFETY of these instructions.

Engine will not Start

SYMPTOM	POSSIBLE CAUSE	SOLUTION
Starter does not rotate	Emergency stop switch pushed down	Check Emergency stop switch. Reset if required.
	Machine controller has not completed self diagnosis	Wait to crank until console indicator lights and gauges have completed system check
	Controller sensing parking brake is released	Toggle Parking Brake Release switch. Turn ignition key ON and OFF
	Propulsion control lever NOT in STOP position	Move lever to STOP
	Fuse F1 defective	Check console fuse and replace
	Battery discharged	Check Battery, charge if necessary
	Battery cable connections loose, corroded or disconnected	Clean and tighten terminal connections
	Starter relay fault	Call for service to correct fault
	Ignition switch defective	Call for service to correct fault
	Starter solenoid or starter defective	Call for service to correct fault
	Empty fuel tank	Fill
	Fuel solenoid at fuel pump defective	Call for service to test/replace
	Defective wiring	Call for service to correct fault

Difficult Starting & Poor / Irregular Performance

SYMPTOM	POSSIBLE CAUSE	SOLUTION
Difficult Starting and Poor or Irregular Performance	Low battery power	Check battery
	Battery discharged	Charge battery, if necessary
	Battery cable connections loose or disconnected	Clean and tighten terminal connections, cover with acid-free grease
	Using too high a viscosity oil in low ambient temperatures	Use appropriate oil grade for the ambient temperature conditions
	Fuel line blockage due to wax separation in winter	Change fuel filters, and bleed fuel system, check for fuel line leaks and loose connections. Always use winter grade fuel in winter. Turn ignition key ON and OFF
	Vibration turned ON	Turn vibration OFF
	Blocked air cleaner element	Clean or replace element
	Incorrect valve clearances	Call for service to adjust
	Defective fuel injectors	Call for specialist service
	Electric fuel pump failure	Replace fuel pump
Fuel pump fuse F2 defective	Replace fuse	

Engine Makes Excessive Fumes

SYMPTOM	POSSIBLE CAUSE	SOLUTION
Engine Makes Excessive Fumes	Engine oil level too high	Drain engine oil to correct level on the dip stick
	Blocked air cleaner element	Clean or replace element.
	Low compression due to poor condition of the valve or incorrect valve clearance	Call for specialist service

Engine Overheats - Stop Engine Immediately

SYMPTOM	POSSIBLE CAUSE	SOLUTION
Engine Overheats - Stop Engine Immediately	Engine oil level too low	Check oil level. Replenish oil as necessary
	Engine belt broken	Call for service to correct fault
	Engine coolant level too low	Check coolant level. Replenish coolant as necessary
	Excessive dirt on cooling system	Clean the cooling fins
	Blocked cooling air flow	Call for service to correct fault
	Fan on radiator or radiator cap defective	Replace defective component
	Thermostat defective	Check thermostat. Replace if defective

Low Engine Oil Pressure - Red Warning Light Illuminates

SYMPTOM	POSSIBLE CAUSE	SOLUTION
Low Engine Oil Pressure - Red Warning Light Illuminates	Low engine oil level. (low engine oil pressure warning light should illuminate)	Fill oil level to dipstick mark
	Lubrication system leak	Stop engine and check for leaks. Tighten any loose fittings on the system oil lines

Voltmeter Indicates Low or Negative Value

SYMPTOM	POSSIBLE CAUSE	SOLUTION
Voltmeter Indicates Low or Negative Value	Speed of alternator too low	Check V-belt tension, change belt if required
	Not charging due to defective alternator or regulator	Call for service to correct fault

FUSE TROUBLESHOOTING

Below is a fuse table containing electrical equipment and the associated fuse. If the fuse is not blown, suspect defective wiring. If this is the case, call for service to correct.

SYMPTOM MALFUNCTION	POSSIBLE CAUSE	SOLUTION
Start Relay	Fuse F1	Replace
Vibration Solenoids Power Relay Coil	Fuse F2	Replace
Emergency Stop Brake and Shunt Solenoids Fuel Pump 2 Second Timer/Fuel Shut-OFF	Fuse F3	Replace
Horn Indicator Lamps	Fuse F4	Replace
Water Pump	Fuse F5	Replace
Work Lights Option	Fuse F6	Replace
Back-Up Alarm Option	Fuse F7	Replace
Beacon Option	Fuse F8	Replace
Turn/Stop Lights Option	Fuse F9	Replace
Optional Gauges	Fuse F10	Replace
Audible Alarm Option	Fuse F11	Replace



SECTION 7 - TECHNICAL SPECIFICATIONS

TECHNICAL SPECIFICATIONS

GENERAL IDENTIFICATION

Name of machine	DD-29, DD-31HF, DD-38HF
Type of machine	Double drum vibratory compactor
Serial number and product range	Effective with initial production
Name and address of manufacturer	Volvo Construction Equipment 312 Volvo Way Shippensburg, Pennsylvania 17257-1295

ENVIRONMENTAL INFORMATION

DD-29

Noise Emission

In accordance with the requirements of clause 1.7.4 (f) of Annex 1 of Council Directive...Relating to Machinery 98/37/EC, the following values were measured:

Equivalent continuous A-weighted sound pressure level at operator's station:
(Leq) = 84 dB(A) Engine Only: 88 dB(A) Vibration ON. Units with cab: (N.A.) dB(A) Engine Only; (N.A.) dB(A) Vibration ON.

Guaranteed Maximum A-weighted sound power level of the machine: (Lw) = (109) dB(A) Vibration ON.

These measurements were recorded in accordance with ISO 6394, ISO 6396 and ISO 6395 with engine at manufacturer's rated speed.

Operator's Exposure to Vibration

In accordance with the requirements of clause 3.6.3 (a) of Annex 1 of Council Directive...Relating to Machinery 98/37/EC, the following values were measured:

Arms/hands: The weighted root mean square acceleration value to which the hands are subjected: (Aeq) does not exceed 4.69 m/s².

Body/posterior: The weighted root mean square acceleration value to which the posterior is subjected: (Aeq) does not exceed 0.13 m/s².

These measurements were recorded in accordance with ISO 5349 and ISO 2631 with the machine operating at maximum vibration amplitude and maximum frequency.

DD-31HF

Noise Emission

In accordance with the requirements of clause 1.7.4 (f) of Annex 1 of Council Directive...Relating to Machinery 98/37/EC, the following values were measured:

Equivalent continuous A-weighted sound pressure level at operator's station:
(Leq) = 85 dB(A) Engine Only: 88 dB(A) Vibration ON. Units with cab: (N.A.) dB(A) Engine Only; (N.A.) dB(A) Vibration ON.

Guaranteed Maximum A-weighted sound power level of the machine: (Lw) = (109) dB(A) Vibration ON.

These measurements were recorded in accordance with ISO 6394, ISO 6396 and ISO 6395 with engine at manufacturer's rated speed.

DD-31HF**Operator's Exposure to Vibration**

In accordance with the requirements of clause 3.6.3 (a) of Annex 1 of Council Directive...Relating to Machinery 98/37/EC, the following values were measured:

Arms/hands: The weighted root mean square acceleration value to which the hands are subjected: (Aeq) does not exceed 6.47 m/s².

Body/posterior: The weighted root mean square acceleration value to which the posterior is subjected: (Aeq) does not exceed 0.34 m/s².

These measurements were recorded in accordance with ISO 5349 and ISO 2631 with the machine operating at maximum vibration amplitude and maximum frequency.

DD-38HF

Noise Emission

In accordance with the requirements of clause 1.7.4 (f) of Annex 1 of Council Directive...Relating to Machinery 98/37/EC, the following values were measured:

Equivalent continuous A-weighted sound pressure level at operator's station:
 (Leq) = 81 dB(A) Engine Only: 87 dB(A) Vibration ON. Units with cab: (N.A.) dB(A) Engine Only; (N.A.) dB(A) Vibration ON.

Guaranteed Maximum A-weighted sound power level of the machine: (Lw) = (109) dB(A) Vibration ON.

These measurements were recorded in accordance with ISO 6394, ISO 6396 and ISO 6395 with engine at manufacturer's rated speed.

Operator's Exposure to Vibration

In accordance with the requirements of clause 3.6.3 (a) of Annex 1 of Council Directive...Relating to Machinery 98/37/EC, the following values were measured:

Arms/hands: The weighted root mean square acceleration value to which the hands are subjected: (Aeq) does not exceed 4.69 m/s².

Body/posterior: The weighted root mean square acceleration value to which the posterior is subjected: (Aeq) does not exceed 0.13 m/s².

These measurements were recorded in accordance with ISO 5349 and ISO 2631 with the machine operating at maximum vibration amplitude and maximum frequency.

MACHINE WEIGHTS AND FIGURES DD-29 / DD-31HF

CECE SPEC Weights with ROPS kg (lb)	DD-29	DD-31HF
Operating weight	2873 (6335)	3102 (6840)
Static weight		
- Front drum	1347 (2970)	1419 (3130)
- Rear drum	1526 (3365)	1682 (3710)
Shipping weight (¼ fuel)	2641 (5823)	2871 (6330)
Static linear load		
- Front drum	10.8 kg/cm (60 p/i)	11.3 kg/cm (64 p/i)
- Rear drum	12.2 kg/cm (68 p/i)	13.4 kg/cm (75 p/i)
Capacities liters (gal.)		
Fuel	68.0 (18.0)	68.0 (18.0)
Hydraulic	84.9 (22.4)	84.9 (22.4)
Water	299.0 (79.0)	299.0 (79.0)
Propulsion (Transmission)		
Type of system	Closed-loop hydrostatic parallel circuit to drums	Closed-loop hydrostatic parallel circuit to drums
Drum drive (both)	Pump-axial piston Motor-radial piston, low speed, high torque	Pump-axial piston Motor-radial piston, low speed, high torque
Travel speed (max)	10.6 km/h (6.6 mph)	10.7 km/h (6.6 mph)
Theoretical Gradeability	44.6%	41.7%
Brakes		
Service	Dynamic hydrostatic through propulsion system	Dynamic hydrostatic through propulsion system
Secondary/Parking	Spring applied, hydraulically released on each drum	Spring applied, hydraulically released on each drum
Steering		
Design	Centerpoint articulation	Centerpoint articulation
Type System	Double-acting, hydraulic, single cylinder	Double-acting, hydraulic, single cylinder
Control system	Hydraulic	Hydraulic

Vibration	DD-29	DD-31HF
No. Vibrating Drums	both (2) or front only (1)	both (2) or front only (1)
Type System	Open loop, series circuit	Open loop, series circuit
Frequency (Hz/VPM)	66.7 (4000)	70.0 (4200)
Nominal Amplitude mm (in.)	0.40 (0.016)	0.38 (0.015)
Centrifugal Force kN (lb)	46 (10268)	51 (11575)
Engine		
Model	Kubota V2203M	Kubota V2203M
Cylinders	4	4
Displacement	2197 cc (134.07 cu. in.)	2197 cc (134.07 cu. in.)
Bore	87.0 mm (3.43 in.)	87.0 mm (3.43 in.)
Stroke	92.4 mm (3.64 in.)	92.4 mm (3.64 in.)
Capacity	9.5 liters (10 quarts)	9.5 liters (10 quarts)
Rated Power	32.8 Kw, 44 (hp)@2450 RPM, 104 FT-LB @1700 RPM	32.8 Kw, 44 (hp)@2450 RPM, 104 FT-LB @1700 RPM
Engine Oil Filtration	Type: Spin on	Type: Spin on
Fuel Filtration	Type: Spin on	Type: Spin on
Fuel System Type	Bosch	Bosch
Type Air Cleaner	Dry - 2 stage	Dry - 2 stage
Starting System	12 volt	12 volt
Cooling System	Liquid cooled	Liquid cooled

MACHINE WEIGHTS AND FIGURES DD-38 HF

CECE SPEC Weights with ROPS kg (lb)	DD-38HF	
Operating weight	3809 (8400)	
Static weight		
- Front drum	1780 (3925)	
- Rear drum	2029 (4475)	
Shipping weight (¼ fuel)	3577 (7888)	
Static linear load		
- Front drum	12.9 kg/cm (73 p/i)	
- Rear drum	4.8 kg/cm (83 p/i)	
Capacities liters (gal.)		
Fuel	68.0 (18.0)	
Hydraulic	84.9 (22.4)	
Water	299.0 (79.0)	
Propulsion (Transmission)		
Type of system	Closed-loop hydrostatic parallel circuit to drums	
Drum drive (both)	Pump-axial piston Motor-radial piston, low speed, high torque	
Travel speed (max)	10.1 km/h (6.3 mph)	
Theoretical Gradeability	41.8%	
Brakes		
Service	Dynamic hydrostatic through propulsion system	
Secondary/Parking	Spring applied, hydraulically released on each drum	
Steering		
Design	Centerpoint articulation	
Type System	Double-acting, hydraulic, single cylinder	
Control system	Hydraulic	

Vibration	DD-38HF	
No. Vibrating Drums	both (2) or front only (1)	
Type System	Open loop, series circuit	
Frequency (Hz/VPM)	70 (4200)	
Nominal Amplitude mm (in.)	0.34 (0.013)	
Centrifugal Force kN (lb)	55 (12400)	
Engine		
Model	Kubota V2203M	
Cylinders	4	
Displacement	2197 cc (134.07 cu. in.)	
Bore	87.0 mm (3.43 in.)	
Stroke	92.4 mm (3.64 in.)	
Capacity	9.5 liters (10 quarts)	
Rated Power	32.8 Kw, 44 (hp)@2450 RPM, 104 FT-LB @1700 RPM	
Engine Oil Filtration	Type: Spin on	
Fuel Filtration	Type: Spin on	
Fuel System Type	Bosch	
Type Air Cleaner	Dry - 2 stage	
Starting System	12 volt	
Cooling System	Liquid cooled	

MACHINE DIMENSIONS DD-29 and DD-31HF

Figure 7-1

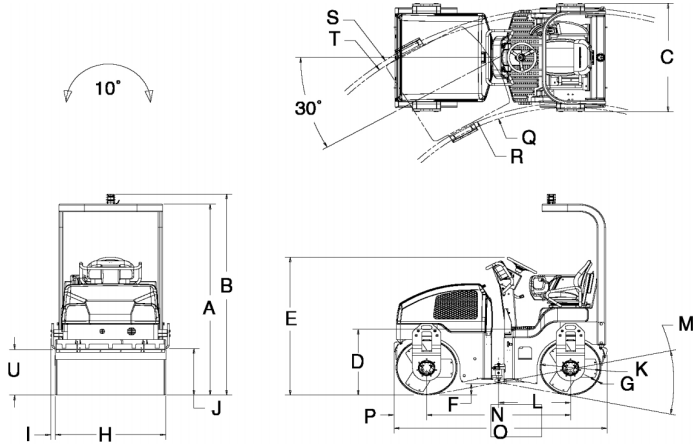

DD-29										
Units	A	B	C	D	E	F	G	H	I	J
Millimeters	2531	2663	1313	897	1824	152	12	1200	57	612
Inches	99.7	104.8	51.7	35.3	71.8	5.9	.47	47.2	2.2	24.1
Units	K	L	M	N	O	P	R	S	T	U
Millimeters	732	862	23°	1725	2556	392	2619	--	3819	481
Inches	28.8	33.9		68.9	100.6	15.4	103.1	--	150.4	18.93

DD-31HF										
Units	A	B	C	D	E	F	G	H	I	J
Millimeters	2533	2665	1313	899	1826	105	14	1200	57	614
Inches	99.7	104.9	51.7	35.5	71.9	4.13	.55	52	2.24	24.17
Units	K	L	M	N	O	P	Q	S	T	U
Millimeters	736	483	23°	1725	2556	392	2559	3879	--	483
Inches	29	19	23°	67.9	100.6	15.4	103	150.4	--	19

MACHINE DIMENSIONS DD-38 HF

Figure 7-2

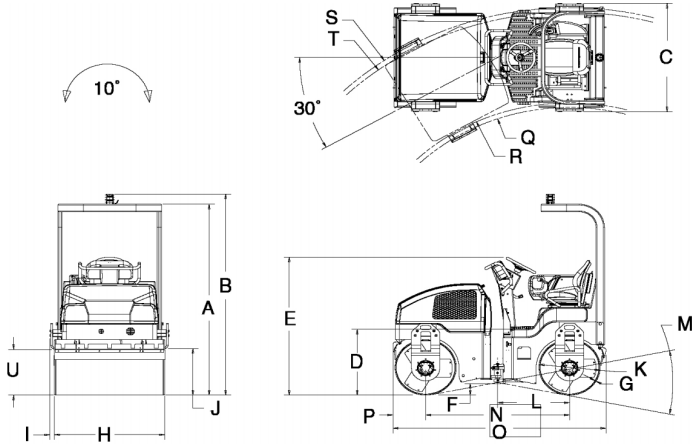

DD-38HF										
Units	A	B	C	D	E	F	G	H	I	J
Millimeters	2536	2668	1435	901	1828	107	16	1320	57	616
Inches	99.8	105	56.5	35.5	72	4.2	.63	52	2.2	24.25
Units	K	L	M	N	O	P	R	S	T	U
Millimeters	740	862	19°	1725	2556	392	2559	--	3879	608
Inches	29.13	33.9	19°	67.9	100.6	15.4	100.75	--	152.7	23.9

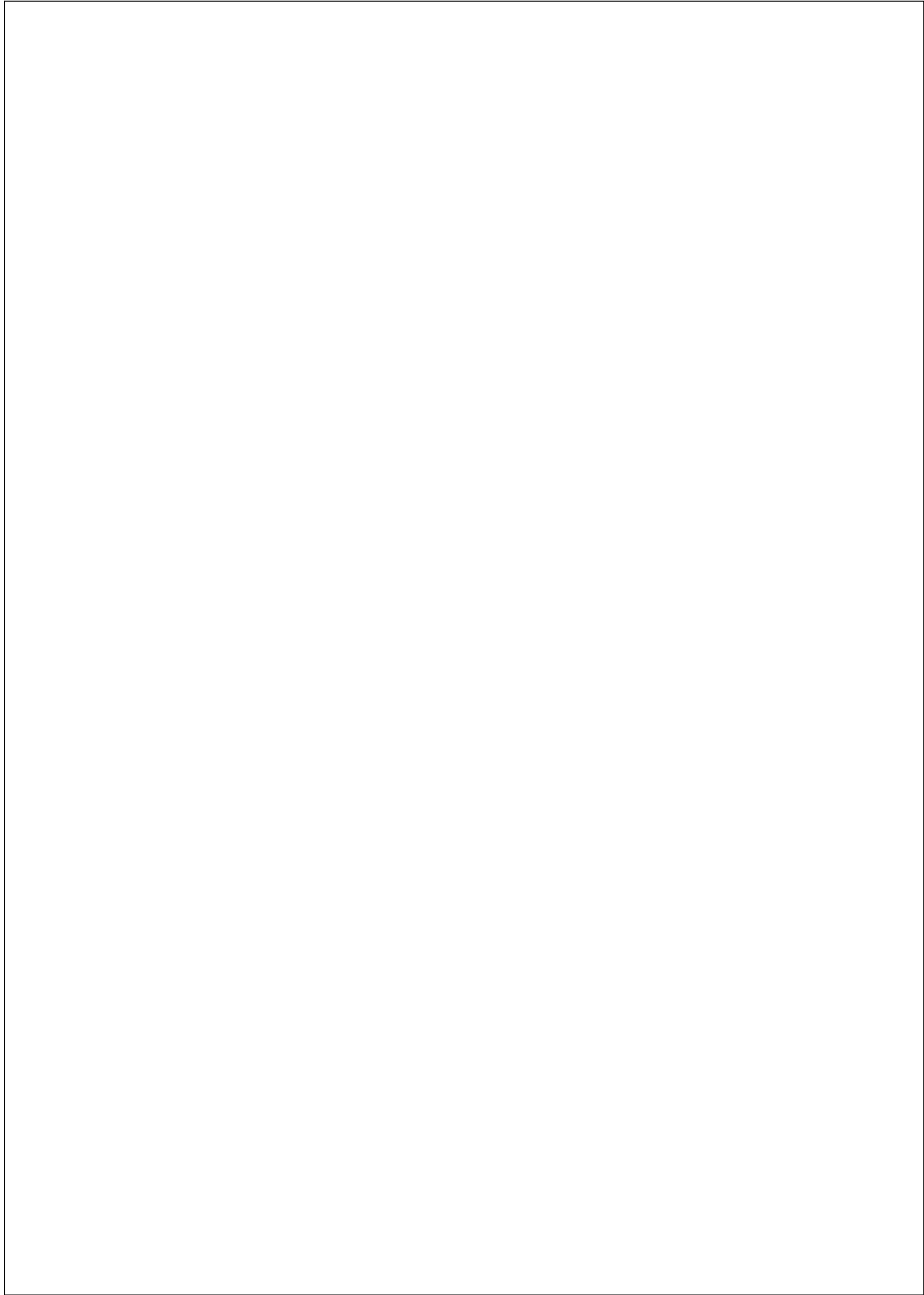



SECTION 8 - FUEL AND LUBRICANT SPECIFICATIONS

FUEL AND LUBRICANT SPECIFICATIONS

GENERAL INFORMATION

Extended warranty is available at no extra charge when you use genuine manufacturer-approved lubricants and parts. See your authorized dealer for details.

Lubrication is an essential part of preventive maintenance, affecting to a great extent for the useful life of the unit. Periodic lubrication of the moving parts reduces to a minimum possibility of mechanical failures. **For maximum machine life and performance, we recommend the use of genuine manufacturer brand lubricants.**

Different lubricants are needed and some components in the unit require more frequent lubricant than others. Therefore, it is important that the instructions regarding types of lubricant and frequency of the application be explicitly followed.

The Lubrication Chart that follows in this section shows those items requiring regular service and the interval at which they should be performed. Details concerning fuel, oil and other lubricants follow the lubrication chart. A regular service program should be geared to the items listed under each interval. These intervals are based on average operating conditions. In the event of extremely severe, dusty or wet operating conditions, more frequent lubrication than specified may be necessary.

All oil levels are to be checked with the machine parked on a level surface and while the oil is cold, unless otherwise specified.

On plug type check points, the oil levels are to be at the bottom edge of the check port.

All grease fittings are SAE STANDARD unless otherwise indicated. Grease non-sealed fittings until grease is seen extruding from the fitting.

Over lubrication on non-sealed fittings will not harm the fittings or components, but under lubrication will definitely lead to a shorter lifetime.

Unless otherwise indicated, items not equipped with grease fittings (linkages, pins, levers, etc.) should be lubricated with oil once a week. Motor oil, applied sparingly, will provide the necessary lubrication and help prevent the formation of rust. An anti-seize compound may be used if rust has not formed. Otherwise, the component must be cleaned first.

Grease fittings that are worn and will not hold the grease gun, or those that have a stuck check ball, must be replaced.







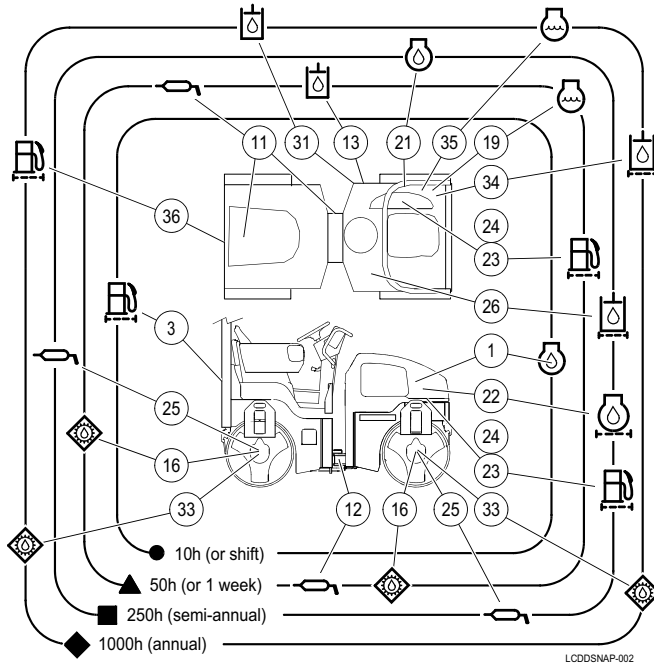

To prevent minor irregularities from developing into serious conditions, the following other services or checks are recommended for the same intervals as the periodic lubrication:

1. Thoroughly wash all fittings, caps, plugs, etc. with non-flammable, non-toxic cleaning solution before servicing, to prevent dirt from entering while performing the service.
2. Lubricants must be at operating temperature when draining.
3. During regular lubrication service, visually check the entire unit in regard to capscrews, nuts and pins being properly secured.
4. Spot check several capscrews and nuts for proper torque. If any are found loose, a more thorough investigation must be made.
5. If a defect is detected which requires special maintenance service, stop the machine operation until the defect has been corrected. If necessary, contact the local distributor for assistance.
6. This symbol  represents an area where lubrication is required.

Periodic lubrication requirements are listed in the following Lubrication Chart. These requirements include lubricant checks and greasing designated areas of the machine.

Figure 8-1



LUBRICATION SCHEDULE CHART			
Grease		Synthetic Transmission Oil	
Engine Oil		Fuel Filter	
Engine Coolant		Engine Oil Filter	
Hydraulic Oil		Hydraulic Oil Filter	
Refer to Page 8-7 for specific oil grades.			
This lubrication schedule is supported by the Maintenance Schedule chart found in Section 5, MAINTENANCE INSTRUCTIONS of this manual.			

SERVICE FUNCTIONS:

S - CHECK A - ADD G - GREASE C - CHANGE
 D - DRAIN F - FILL CL - CLEAN AR - AS REQUIRED

Table 8-2 Lubrication Table

SERVICE INTERVAL	REF NO.	DESCRIPTION	SERVICE	SPECIFICATIONS	COMMENTS
10 HRS. OR DAILY	1 3	ENGINE OIL FUEL TANK	S, A S, A	See (2) next page #2 DIESEL FUEL	Fill To Dipstick Full AR
50 HRS. OR WEEKLY	11 12 13 16 19	STEERING CYL BEARINGS SWIVEL PINS HYDRAULIC OIL ECCENTRIC OIL ENGINE COOLANT	G G S, A S, A S, A	MPG-EP2 GREASE MPG-EP2 GREASE See (3) next page See (4) next page Water/Anti-freeze	3 SHOTS EACH 3 SHOTS EACH FILL TO SIGHT GLASS FILL TO LEVEL HOLE FILL TO FULL MARK
250 HRS. OR SEMI- ANNUALLY	21 22 23 24 25 26	ENGINE OIL ENGINE OIL FILTER FUEL FILTER CARTRIDGE IN-LINE FUEL FILTER PURGE LUBE CARRIER HYDRAULIC OIL FILTER	D, F C C C G C	See (2) next page See (4) next page See (2) (3) next page See (2) (3) next page MPG-EP2 Grease See (2) (3) next page	8.5 L / 10.0 QT MAX. Qty of 1 Qty of 1 Qty of 1 As Required Qty of 1
1000 HRS. OR ANNUALLY	31 33 34 36	HYDRUALIC OIL TANK ECCENTRIC LUBE ENGINE COOLANT FUEL TANK	D, C, L F D, F D, F D, CL, F	See (3) next page See (4) next page Water/Anti-freeze #2 DIESEL FUEL	84.9 L (22.4 GAL) 13.5 L (14.0 QTS) FILL TO FULL MARK 68.1 L (18.0 GAL)

NOTES:

1. See Section 5 for Initial Break-In Maintenance.
2. Multi-Purpose Premium Engine Oil: SAE 15W-40
3. Mobil DTE 15M Hydraulic Oil or equivalent ISO VG 46 VI 140 (min) above 12° C (10° F). For temperatures below -12 °C (10° F), use Mobil SHC 624 Hydraulic Oil or equivalent ISO VG 32.
4. Mobil SHC 630 or equivalent ISO VG 220

FLUID CAPACITIES

The following fluid capacities are provided for servicing personnel who must perform machine maintenance in remote locations where complete shop facilities and resources are not available. These capacities will give the servicing personnel an approximation of the fluid capacities of the components to be serviced. Always ensure that the specified method of checking for accurate fluid levels is used.

Table 8-3: Fluid Capacities

FLUID / OIL	APPROXIMATE CAPACITY
	DD-29/31HF/38HF
Diesel Fuel	68 liters (18.0 gallons)
Hydraulic Oil	84.9 liters (22 gallons)
Engine Oil	9.5 liters (10 quarts)
Engine Coolant	9.5 liters (10 quarts)
Water Tank	299.0 liters (79.0 gallons)
Eccentric Oil	13.5 liters / 14 quarts

HYDRAULIC OIL REQUIREMENTS AND SPECIFICATIONS

The quality of the hydraulic oil is important to the satisfactory performance of any hydraulic system. The oil serves as the power transmission medium, system coolant, and lubricant. Selection of the proper oil is essential to ensure proper system performance and life. For the specifications and requirements that hydraulic oil used in this machine should meet, refer to Table 8-3.

Table 8-4:Hydraulic Oil Specifications

SPECIFICATION	REQUIREMENT
Viscosity	60 SUS minimum at operating temperature 7500 SUS minimum at starting temperature 150 to 225 SUS at 100° F (generally) 44 to 48 SUS at 210° F (generally)
Viscosity Index	90 minimum
Aniline Point	-175 minimum
API Gravity	28 minimum Paraffinic oils: 28 or more Mixed base: 24 to 28 Naphthalic or asphaltic base: 24 or less
Recommended Additives	Rust and oxidation inhibitors Foam Depressant
Desirable Characteristics	Stability of physical and chemical characteristics High demulsibility (low emulsibility) for separation of water, air, and contaminants Resistance to the formation of gums, sludges, acids, tars, and varnishes High lubricity and film strength

The following are oils THAT meet above specifications.

Temperatures above 10° F (-12° C): International Harvester: Hy-Tran
Mobil Oil Company: Mobil DTE 15M
Sun Oil Com.: Sun Oil 2105

Temperatures below 10° F (-12° C): Auto Transmission Fluid: Type F
Mobil Oil Company: Mobil DTE 13
Shell Oil Company: Tellus T-27

LUBRICATING OIL/GREASE (EXCEPT ENGINE)**Extreme Pressure Multipurpose Lubricant**

This gear lubricant is compounded to achieve high load carrying capacity and meet the requirements of either API-GL-5 or MIL-L-2105C. Unless otherwise specified, SAE-90 viscosity oil may be used for year-round service. Low temperature usage is restricted as follows:

Table 8-5: Viscosity Temperatures

SAE VISCOSITY NO.	MIN. AMBIENT TEMP. °F (°C)
75W	-40° F (-40° C)
80W	-15° F (-26° C)
85W	+10° F (-12° C)
90	+20° F (-7° C)
140	+40° F (+4° C)
250	+50° F (+10° C)

Extreme Pressure Multipurpose Grease

This is a lithium soap base grease with a high load carrying capacity. The following properties are recommended.

Table 8-6: Multipurpose Grease Properties

PROPERTY	SPECIFICATION
Timken OK Load	40 lb. minimum
Dropping Point	350° F (177° C) min.
Oil Viscosity	75 SUS minimum at 210° F (99° C)
Water Resistance	Excellent

Under normal operating conditions, the following consistency grades are recommended:

Table 8-7: Consistency Grades

AMBIENT TEMPERATURE °F (°C)	CONSISTANCY GRADE
Below 0° F (Below -18° C)	NLGI No. 0
0 to 100° F (-18 to 38° C)	NLGI No. 1 or No. 2
Over 100° F (Over 38° C)	NLGI No. 2 or No. 3

Synthetic Component Lubricant

This gear lubricant provides better thermal and oxidation stability than conventional mineral oils. The lubricant has naturally high viscosity indexes compared to mineral oils, providing lower viscosity at lower temperatures and higher viscosity at higher temperatures (Table 8-7).

Table 8-8

PROPERTY	SPECIFICATION
ISO Viscosity Grade	220
API Gravity	31.4
Viscosity Index	152
Viscosity:	
cSt at 40° C	217
cSt at 100° C	25.9
SUS at 100° F	1122
SUS at 210° F	127

ENGINE LUBRICATING OIL SPECIFICATIONS

NOTE: For latest applicable engine lubricating oil specifications, contact engine manufacturer, distributor or your manufacturer authorized distributor.

DIESEL FUEL SPECIFICATIONS

Kubota diesel engines have been developed to take advantage of the high energy content and generally lower cost of No. 2 Diesel Fuels. Refer to the specifications shown in Table 8-8.

Table 8-9 Fuel Oil Specifications

Flash Point	125° F (52° C) minimum
Water and sediment, volume	0.05% maximum
Carbon residue on, 10 percent residum	0.35% maximum
Ash, Weight	0.01% maximum
Distillation Temperatures, 90% Point	540° F (282° C) minimum 640° F (338° C) maximum
Viscosity kinematic cSt or mm ² /s at 40° C	1.9 minimum 4.1 maximum
Viscosity Saybolt, SUS at 100° F	32.6 minimum 40.1 maximum
Sulfur, Weight	0.50% maximum
Copper Strip Corrosion	No.3 maximum
Cetane Number	40 minimum

HAZARDOUS SUBSTANCE PRECAUTION



HAZARDOUS SUBSTANCE PRECAUTION

The following information is provided to assist the machine owners and operators. Further information may be obtained by contacting your Distributor.

Table 8-10 Hazardous Substance Precaution

The following substances may be produced during the operation of this machine and may be hazardous to your health.

SUBSTANCE	PRECAUTION
Engine Exhaust Fumes	Avoid breathing fumes
Engine Exhaust Fumes	Avoid buildup of fumes in confined spaces
Electric Motor Dust (Brushes/Insulation)	Avoid breathing during maintenance
Brake Lining Dust*	Avoid breathing during maintenance

* Only on machines with dry axle brakes

The following substances are contained in or emitted by this machine and may be hazardous to your health if used incorrectly.

SUBSTANCE	PRECAUTION
Antifreeze (Water-cooled engine)	Avoid ingestion, skin contact, and breathing fumes
Hydraulic Oil	Avoid ingestion, skin contact, and breathing fumes
Engine Lubricating Oil	Avoid ingestion, skin contact, and breathing fumes
Preservative Grease	Avoid ingestion, skin contact, and breathing fumes
Rust Preventative	Avoid ingestion, skin contact, and breathing fumes
Engine Fuel	Avoid ingestion, skin contact, and breathing fumes
Battery	Avoid ingestion, skin contact, and breathing fumes
SAE Gear Oil	Avoid ingestion, skin contact, and breathing fumes

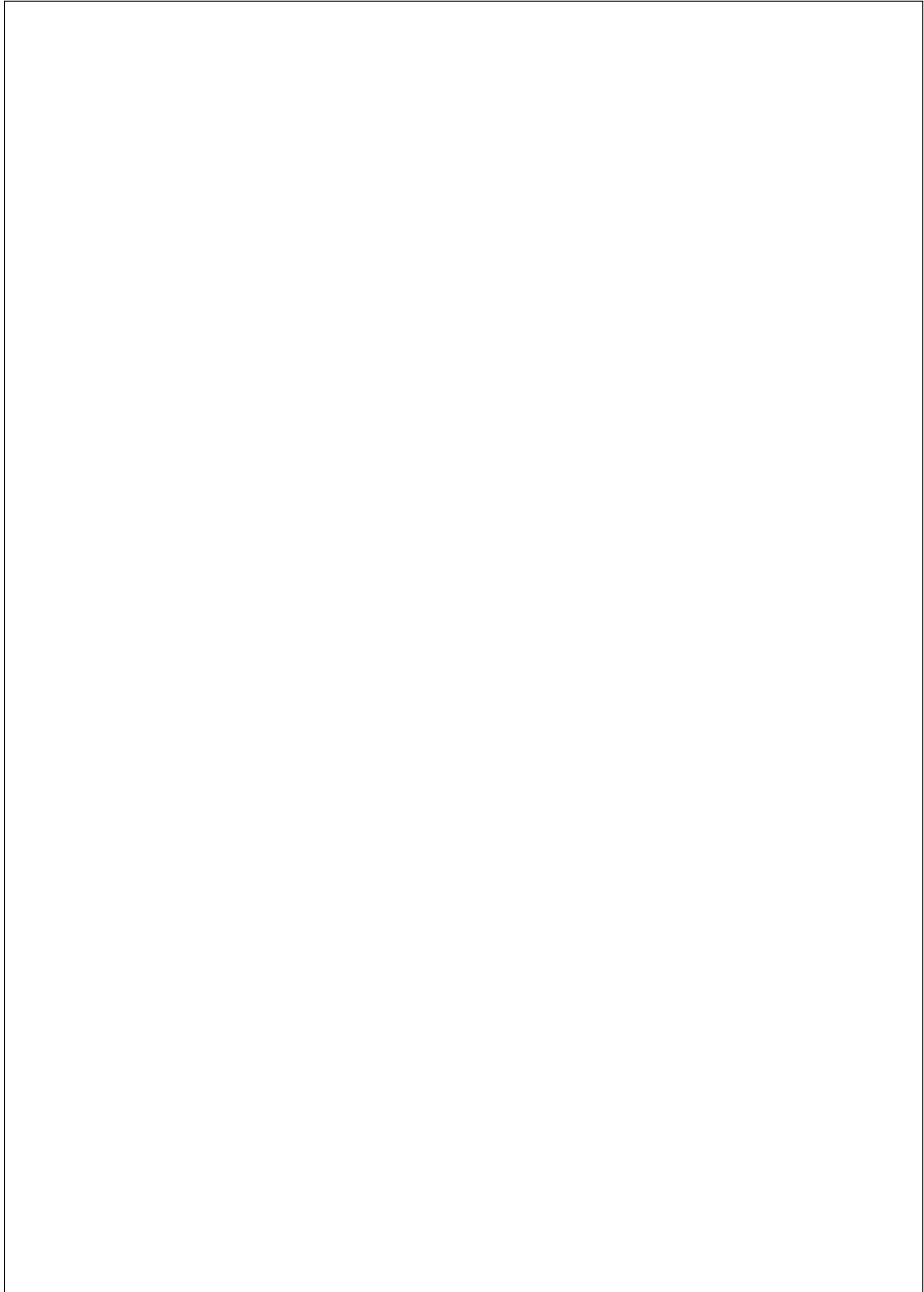



SECTION 9 - TORQUE SPECIFICATIONS

TORQUE SPECIFICATIONS

SAE TORQUE CHART

Use the following Recommended Torque Chart for bolts and nuts of SAE Grade 5 or better quality. If other torques are required, they will be indicated in the text.

NOTE: Torque values are based on plated, yellow zinc, dichromate bolts.

BOLT (COURSE)	TORQUE		BOLT (FINE)	TORQUE	
	lbs.-ft.	N-m		lbs.-ft.	N-m
1/4 - 20	9	12	1/4 - 28	1	1
5/16 - 18	19	26	5/16 - 24	1	2
3/8 - 16	37	50	3/8 - 24	2	5
7/16 - 14	59	80	7/16 - 20	6	8
1/2 - 13	90	122	1/2 - 20	00	13
9/16 - 12	130	176	9/16 - 18	45	19
5/8 - 11	180	244	5/8 - 18	05	27
3/4 - 10	320	434	3/4 - 16	55	48
7/8 - 9	515	698	7/8 - 14	70	77
1 - 8	775	1051	1 - 12	45	114
1 1/8 - 7	1100	1492	1 1/8 - 12	230	166
1 1/4 - 7	1540	2088	1 1/4 - 12	710	231
1 3/8 - 6	2020	2739	1 3/8 - 12	300	311
1 1/2 - 6	2690	3648	1 1/2 - 12	020	409

NOTE: Use Loctite™ 271 on all bolts larger than 5/16. Use Loctite™ 242 on bolts 5/16 and smaller. Apply enough Loctite™ to fill all gaps between the engaged bolt and nut threads.

All thread fasteners will be Loctited except the following:

1. Nylon insert nuts
2. Whizlock bolts and nuts
3. Fasteners less than ¼ inch (6 mm) diameter
4. If instructed not to apply Loctite

ISO METRIC TORQUE CHART

Use the following Recommended Torque Chart for bolts and nuts of ISO Metric strength Class 8.8 or better. If other torques are required, they will be indicated in the text.

NOTE: Torque values are based on plated, yellow zinc, dichromate bolts.

BOLT SIZE	TORQUE	
	lbs.-ft.	N.m
M6 X 1.0	9	12
M8 X 1.25	21	28
M10 X 1.5	45	61
M12 X 1.75	79	105
M14 X 2.0	125	170
M16 X 2.0	195	265
M20 X 2.5	380	515
M24 X 3.0	660	895
M30 X 3.5	1310	1780
M36 X 4.0	2290	3100

NOTE: Use Loctite™ 271 on all bolts larger than M8. Use Loctite™ 242 on bolts M8 and smaller. Apply enough Loctite™ to fill all gaps between the engaged bolt and nut threads.

All thread fasteners will be Loctited except the following:

1. Nylon insert nuts
2. Whizlock bolts and nuts
3. Fasteners less than ¼ inch (6 mm) diameter
4. If instructed not to apply Loctite

DD-29/31HF/38HF SPECIAL TORQUE VALUES

The following charts contain special torque for specific fasteners that are different from those listed on the Torque Charts.

Table 9-1 Engine Area

FUNCTION OF FASTENER	FASTENER SIZE	TORQUE		LOCTITE # (IF USED)
		lbs.-ft.	N-m	
Propulsion Pump Mounting Housing Attaching Bolt	M10 X 50	40-45	29-33	242

Table 9-2 Miscellaneous Areas

FUNCTION OF FASTENER	FASTENER SIZE	TORQUE		USE LOCTITE #
		N-m	lbs.-ft.	
Rear Frame Filter Plate Attaching Bolt	M8 X 1.25	13	9.5	--
ROPS Attaching Bolt	M20 X 90	271	200	271
Drum Drive Motor to Drive Plate Attaching Nut	M10 X 1.5	170	125	271
Vibration Motor Attaching Bolt	M10	70	52	271
Eccentric Bearing Cover Attaching Bolt	M10 X 25	41	30	271
Eccentric Bearing Housing Attaching Bolt	M12 X 1.75 X 35	108	80	271
Hood Grab Handle Attaching Bolt	M5 X 0.08 X 30	4	35 lb.-in	--
Hood Latch Keeper Locknut	M5 X 0.8	3	26.5 lb.-in	--
Hood Latch Locknut	M5 X 0.8	3	26.5 lb.-in	--
Fuel Filter Fitting	NA	25	19	--
Ground Strap Bolt	M12 X 1.25 X 35mm	115	86	--
Radiator Plate Top Isolator Bolt	M10 X 1.25 X 16mm	65	48	



SECTION 10 - SCHEMATICS

SCHEMATICS

GENERAL INFORMATION

Hydraulic and electrical schematics are included here for the convenience of the owner/operator. Additional full-size copies of the schematics are available by contacting the manufacturer. See your authorized dealer for assistance, if required.

For ultimate machine life and maximum performance, we recommend the use of genuine manufacturer brand parts.

The electrical and hydraulic schematics included herein that are applicable to the DD-29/31HF/38HF Vibratory Asphalt Compactors are outlined below.

Electrical Schematics

- Electrical Schematic for the DD-29/31HF/38HF Vibratory Asphalt Compactors, Drawing No. 13305313, page 10-3.

Hydraulic Schematics

- Hydraulic Schematic for the DD-29 Vibratory Asphalt Compactors, Drawing No. 59223479, page 10-4.
- Hydraulic Schematic for the DD-31HF/38HF Vibratory Asphalt Compactors, Drawing No. 59223487, page 10-5.

Electrical Schematic for DD-29/31HF/38HF Vibratory Asphalt Compactors (13305313)

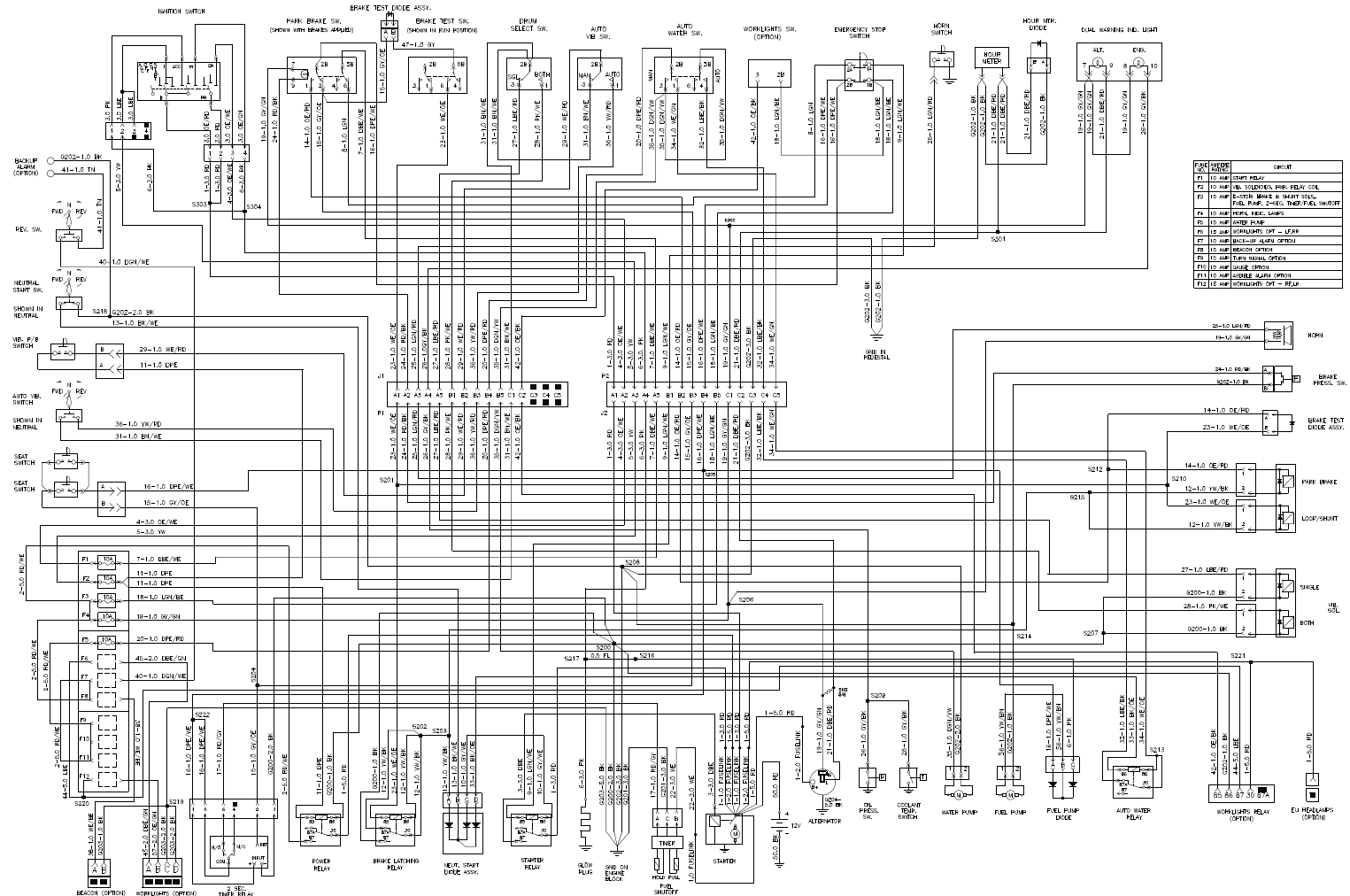

OM13305313_0B01

Hydraulic Schematic DD-29 Vibratory Compactors (59223479)

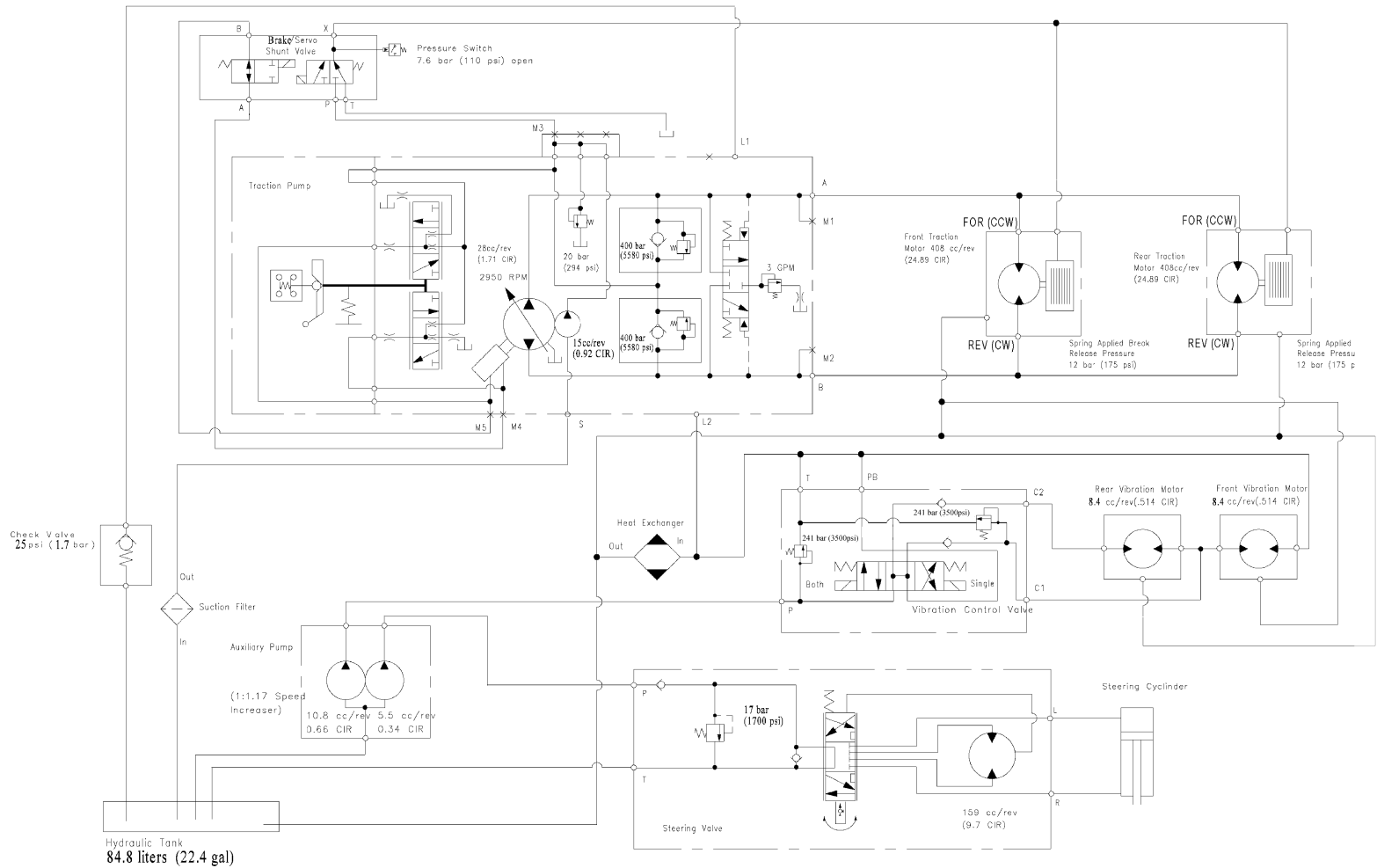

OM59223479_0D01

Hydraulic Schematic for DD-31HF/38HF Vibratory Compactors (59223487)

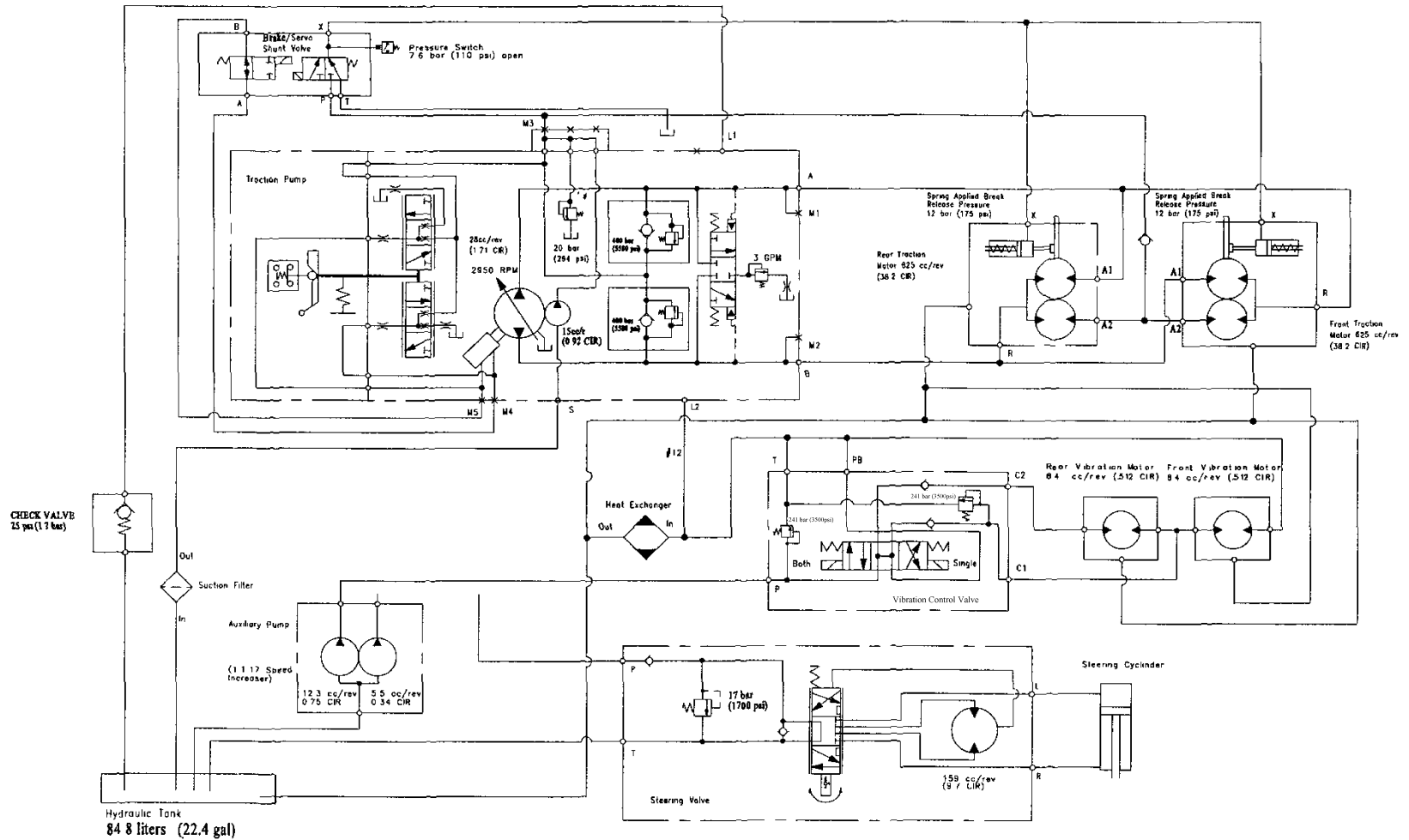

OM59223487_0B01





RECOMMENDED SPARE PARTS

Recommended Spare Parts

<u>Assembly</u>	<u>Description</u>	<u>1000</u> <u>Hrs</u>	<u>2000</u> <u>Hrs</u>	<u>3000</u> <u>Hrs</u>	<u>CPN</u>
Air Cleaner					
	Valve			1	59144147
	Cover			1	59144196
	Primary Filter Element	2	2	2	59144170
	Safety Element		1	1	59144188
Drums					
	Bearing			4	13185756
	Bearing		2		50269984
	Wear Sleeve		2		59539064
	Vibration Motor (DD-29)			1	13357322
	Vibration Motor (DD-31HF/38HF)			1	59402537
	V Ring Seal			2	59027755
	Seal		2		59133900
	Drive Motor (DD-29)			1	13402276
	Drive Motor - Front (DD-31HF/38HF)			1	59243017
	Drive Motor - Rear (DD-31HF/38HF)			1	59240309
	Magnetic Plug			2	59144428
	Shock Mount		6		59600205
	Shock Mount (DD-31HF/38HF)			3	59269688
Drum Skirt					
	Hydraulic Filter	2	2	2	59075440
	Battery Hold Down		1		58870627
Engine					
	<i>Effective with All S/Ns</i>				
	In-Line Fuel Filter	1	1	1	54477161
	Engine Fan			1	13384136
	Starter			1	13496476
	Alternator			1	13496898
	Fan Belt			1	13478086
	Fuel Pump			1	13496492

RECOMMENDED SPARE PARTS

SECTION 11

<u>Assembly</u>	<u>Description</u>	<u>1000 Hrs</u>	<u>2000 Hrs</u>	<u>3000 Hrs</u>	<u>CPN</u>
	Engine Shock Mount			1	59256982
	Oil Cooler			1	59265033
	Sandwich Mount			1	59259606
	Oil Pressure Sender		1		58878000
	Muffler			1	59268508
	Radiator Hose, Lower			1	13353768
	Radiator Hose, Top			1	13325204
	Temperature Sender			1	59443408
	Radiator Cap - Sealed			1	13400890
Frame					
	Fuel Cap		1		59212951
	Bearing		1		50275445
	Pin			1	59265959
	Pin			1	59265942
	Breather Filtered Vent		1		59093351
	Sight Plug			1	59121954
	Cable			1	59436741
	Bearing		1		50268127
	Cap		1		59180992
	Steering Cylinder		1		59269563
Hydraulics					
	Pressure Switch			1	59090878
	Vibration/Steering Pump			1	59227041
	Propulsion Pump			1	13219175
	Brake Valve			1	59225573
	Vibration Valve			1	59212886
Instrument Panel					
	Parking Brake Switch			1	13305420
	Water System Switch			1	59226597
	Oil Pressure Gauge		1		59046904
	Voltmeter Gauge			1	59044297
	Water Temperature Gauge			1	59132324
	Parking Brake Test Switch		1		59214742

SECTION 11

RECOMMENDED SPARE PARTS

<u>Assembly</u>	<u>Description</u>	<u>1000 Hrs</u>	<u>2000 Hrs</u>	<u>3000 Hrs</u>	<u>CPN</u>
Miscellaneous					
	Seat Belt			1	13342720
	Battery Switch (EU models)			1	59271445
	Dual Switch Seat Kit		1		13167945
	Hood Grab Handle			1	54469390
	Hood Strap			1	13207063
	Hood Latch		1		13233242
	Relay	1			58965377
	Fuse Block	1			59434290
	Fuse 5 Amp	1	1	1	59465591
	Fuse 10 Amp	1	1	1	59325712
	Fuse 15 Amp	1	1	1	59483339
	Battery		1		54616081
	Horn		1		13469010
	Horn Brush Kit			1	59393371
Pedestal					
	Ignition Key	1	1	1	58917261
	Horn Button	1	1	1	58858572
	Blank Switch			1	58835398
	Top Dust Boot			1	59108100
	Bottom Dust Boot			1	59108605
	Ignition Switch		1		13305180
	Shock Mount		2		59653543
	Steering Control Valve			1	59212860
	Steering Wheel			1	58858564
	Steering Column			1	58858580
Side Console					
	Drum Vibrate Switch			1	59214718
	F-Stop-R Control		1		13316385
	F-Stop-R Cable		1		54520986
	Clevis Assembly			1	59662312
	Emergency Stop Switch		1		59111450
Water					
	Rubber Scraper (47" Drum)	1	1	1	59272096
	Rubber Scraper (49" Drum)	1	1	1	13169917
	Rubber Scraper (52" Drum)	1	1	1	59272237
	Rubber Scraper (54" Drum)	1	1	1	13209739

RECOMMENDED SPARE PARTS

SECTION 11

<u>Assembly</u>	<u>Description</u>	<u>1000 Hrs</u>	<u>2000 Hrs</u>	<u>3000 Hrs</u>	<u>CPN</u>
	Backing Bar (47" Drum)			1	59272088
	Backing Bar (49" Drum)			1	13171962
	Backing Bar (52" Drum)			1	59272229
	Backing Bar (54" Drum)			1	13209747
	Rubber Pad			1	59225144
	Plug Pipe		4		59579599
	Hose Barb		2		59579607
	Split Eye	10	10	10	13447289
	Cap	10	10	10	13447297
	Nozzle	10	10	10	59727891
	Strainer	10	10	10	59727883
	Gasket	10	10	10	59727909
	Spring	4	4	4	59478743
	Spray Tube Assembly	1	1	1	13199807
	Water Pump		1		59262410
	Electrical Receptacle			1	59436865
	Connection			1	59572867
	Drain			1	95250692
	Ball Valve, Two Way			1	59226076
	Wedge			1	59436873
	Water Tank Cap	1			54489000
	Water Strainer	1	1	1	59044321
	Ball Valve			1	58825498
	Check Valve			1	58848755
Kits					
	Vibration Motor Seal Kit (DD-29)		1		59489658
	Vibration Motor Seal Kit (DD-31HF/ 38HF)		1		59402537
	Drive Motor Seal Kit (DD-29)		1		54505383
	Drive Motor Brake Disc Kit (DD-29)		1		13493952
	Drive Motor Seal Kit (DD-31HF/ 38HF)		1		54504667
	Drive Motor Brake Disc Kit (DD- 31HF/38HF)		1		54504634
	Vibration/Steering Pump Seal Kit		1		58898677
	Brake Valve Seal Kit			1	54513916

SECTION 11

RECOMMENDED SPARE PARTS

<u>Assembly</u>	<u>Description</u>	<u>1000 Hrs</u>	<u>2000 Hrs</u>	<u>3000 Hrs</u>	<u>CPN</u>
	Vibration Valve Seal Kit			1	54507231
	Steering Control Valve Seal Kit			1	54514666
	Propulsion Pump Seal Kit		1		59051755
Optional Equipment					
	<i>Edge Compactor</i>				
	Ball Valve			1	58825498
	<i>Spinner Kit</i>				
	Spinner Kit			1	59199141
	<i>Backup Alarm</i>				
	Backup Alarm			1	54535844
	Fuse, 10 Amp			1	59325712
	<i>Worklight</i>				
	Worklight Light Bulb	1			58875543
	Rocker Switch			1	54479373
	<i>Inside Scraper</i>				
	Inside Scraper (47" Drum)			1	59272419
	Inside Scraper (49" Drum)			1	13171954
	Inside Scraper (52" Drum)			1	59272443
	Inside Scraper (54" Drum)			1	13212725
	<i>Urethane Scraper</i>				
	Rubber Scraper (47" Drum)			1	13166996
	Rubber Scraper (49" Drum)			1	13172044
	Rubber Scraper (52" Drum)			1	13167002
	Rubber Scraper (54" Drum)			1	13212733
	<i>Urethane Inside Scraper</i>				
	Inside Scraper (47" Drum)			1	13213202
	Inside Scraper (49" Drum)			1	13213210
	Inside Scraper (52" Drum)			1	13213186
	Inside Scraper (54" Drum)			1	13213194
	<i>Cocoa Mat Spray System</i>				
	Cocoa Mat (47" Drum)			1	58948456
	Cocoa Mat (49" Drum)			1	13172374
	Cocoa Mat (52" Drum)			1	58948472
	Cocoa Mat (54" Drum)			1	13212929
	<i>Beacon Light</i>				

<u>Assembly</u>	<u>Description</u>	<u>1000 Hrs</u>	<u>2000 Hrs</u>	<u>3000 Hrs</u>	<u>CPN</u>
	Strobe Light		1		59083105
	Bulb	1	1	1	59007450
	<i>Brake Light</i>				
	Fuse, 5 Amp	1	1	1	59465591
	<i>Low Fuel Alarm</i>				
	Solid State Encapsulated Module			1	59262469

+ Designates parts that are to be replaced within the specified time intervals as stated in the maintenance schedule.

LUBRICANTS

	1 Qt.	1 Gal.	5 Gal.	55 Gal.
All-Season Premium Hydraulic Oil	n/a	n/a	59045179	59045187
Multi-Purpose Premium Engine Oil	59022343	59023507	57022327	59022335
Premium Limited-Slip Component Lubricant	13248455	13248463	59022418	59022426
Premium Multi-Purpose ATF	13248471	13248489	59023572	59023580
Synthetic Component Lubricant	13248430	13248448	59877597	59022459
Synthetic Plus Component Lubricant	13248414	13248422	59046177	59046165

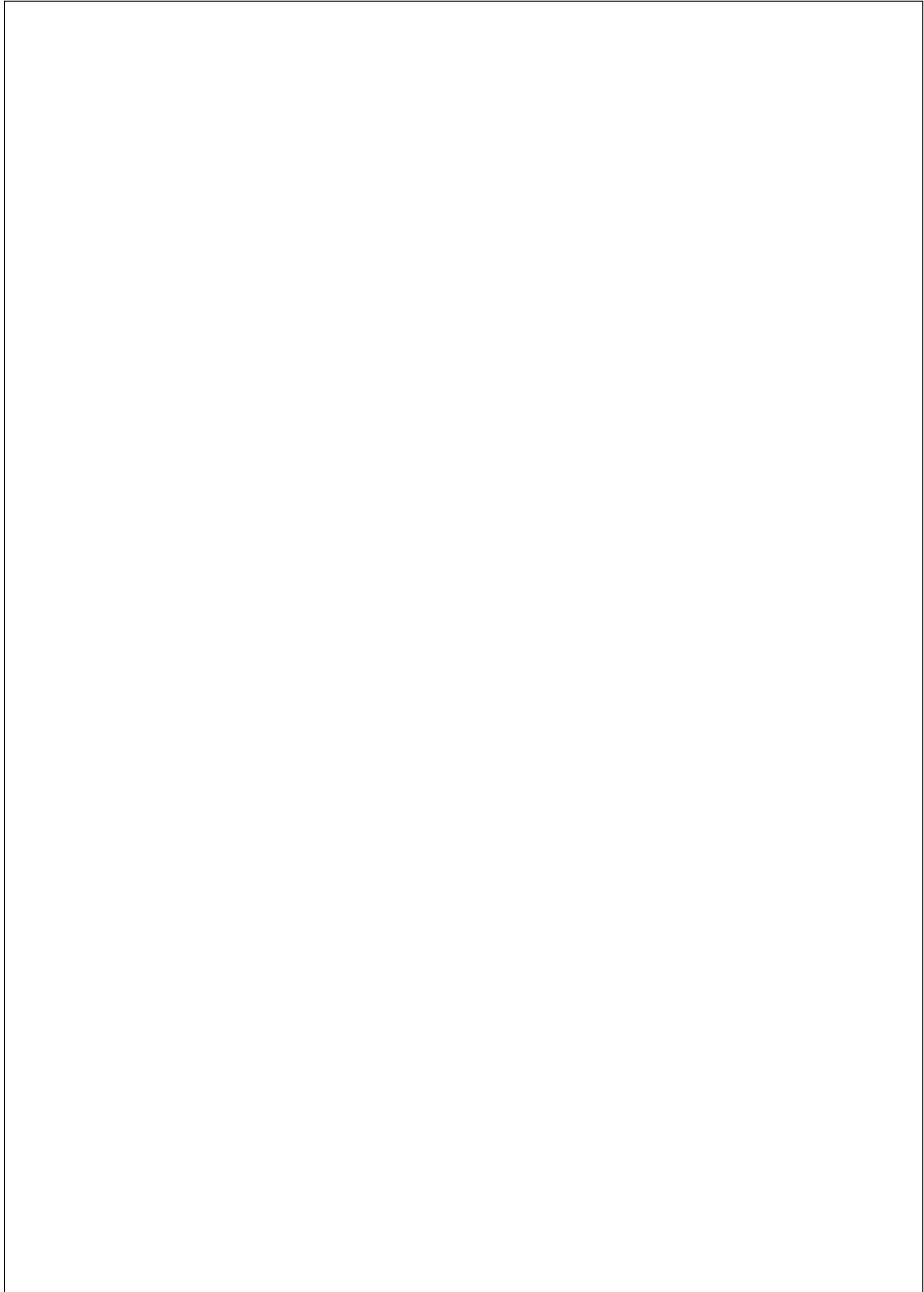

SUBJECT INDEX

NUMERICS

10 HOUR OR DAILY ROUTINE MAINTENANCE	5-13
1000 HOUR OR ANNUAL ROUTINE MAINTENANCE	5-31
250 HOUR OR QUARTERLY ROUTINE MAINTENANCE	5-24
50 HOUR OR WEEKLY ROUTINE MAINTENANCE	5-20

A

After cleaning	5-12
----------------	------

B

BE AWARE OF SAFETY INFORMATION	1-2
BRAKES	7

C

CAUTION	1-3
Change Air Filter Elements	5-38
Change Eccentric Lube	5-34
Change Engine Fuel Filter Element and In-Line Fuel Filter	5-26
Change Engine Oil and Filter	5-25
Change Hydraulic Oil Filter	5-29
Check Air Cleaner	5-15
Check Air Cleaner Connections and Ducts For Leaks	5-5
Check Air Cleaner Restriction Indicator	5-15
Check Air Cleaner System Integrity and Filter Elements	5-23
Check All Shock Mounts	5-13
Check Battery, Clean And Grease Terminals	5-20
Check Eccentric Oil Level	5-23
Check Engine Coolant Level	5-14, 5-24
Check Engine Oil Level	5-13
Check Fuel Level	5-16
Check Hydraulic Oil Level	5-22
Check List	1-18, 1-21
Check Parking Brake	5-18
Check Water Tank Level	5-17
Checking and Removing the Air Cleaner Primary Element	5-5
Clean / Wash / Lubricate the Machine	5-11
Clean Fuel Tank	5-40
Clean Radiator and Oil Cooler	5-14
Clean the Primary Air Cleaner Element	5-7
Clean Water Strainer	5-19
Consistency Grades	8-9
CONTROLS	6
Crush Area	1-16, 1-19

D

DAILY PRECAUTIONS AFTER WORK	4-18
DD-24/30/28HF/34HF SPECIAL TORQUE VALUES	9-4
Decal Location	1-15
DIESEL FUEL SPECIFICATIONS	8-10
Difficult Starting & Poor / Irregular Performance	6-4
Drain and Flush Radiator, Replace Engine Coolant	5-35
Drain and Flush Water Tank and Spray Bars	5-33
Drain hydraulic tank	5-31
Drain, Clean, and Fill Hydraulic Oil Tank	5-31
DRUM WATER SPRAY SYSTEM	6
DRUMS	5

E

Electrical Schematics	10-2
ENGINE	6
Engine Area	9-4
Engine damage	5-39
ENGINE IDENTIFICATION	4
ENGINE LUBRICATING OIL SPECIFICATIONS	8-10
Engine Makes Excessive Fumes	6-4
Engine Overheats - Stop Engine Immediately	6-5
Engine Will Not Start	6-3
ENVIRONMENTAL INFORMATION	7-3
Extreme Pressure Multipurpose Grease	8-8
Extreme Pressure Multipurpose Lubricant	8-8

F

FLUID CAPACITIES	8-6
FUEL AND LUBRICANT SPECIFICATIONS	8-2
Fuel is flammable	5-16, 5-40
Fuel Oil Specifications	8-10
FUSE TROUBLESHOOTING	6-6

G

GENERAL	1-3
GENERAL IDENTIFICATION	7-2
GENERAL INFORMATION	5, 4-2, 8-2, 10-2
GENERAL MAINTENANCE INFORMATION	5-2
Grease Articulation Pin Bearings	5-21
Grease Steering Cylinder Pin Bearings	5-21

H

Handling Fluids and Oil, Fuel Filters	5-3
HAZARDOUS SUBSTANCE PRECAUTION	1-14, 8-11
Hot Fluid Pressure	1-17

SUBJECT INDEX

HYDRAULIC OIL REQUIREMENTS AND SPECIFICATIONS	8-7
Hydraulic Oil Specifications	8-7
Hydraulic Schematics	10-2

I	
IDENTIFICATION DATA	3
Improper Operation	1-17, 1-19
INGERSOLL-RAND MACHINE SYMBOLS	2-2
Ingersoll-Rand Synthetic Component Lubricant	8-9
INITIAL BREAK-IN MAINTENANCE	5-3
INSTRUCTION MANUAL STORAGE	4
INTERNATIONAL DECALS WITH INTERPRETATION	1-19
INTERNATIONAL SYMBOLS	2-3
INTRODUCTION	2

L	
Loading the Machine Under Its Own Power (Drive On) For Transporting	4-19
Low Engine Oil Pressure - Red Warning Light Illuminates	6-5
LUBRICATING OIL/GREASE (EXCEPT ENGINE)	8-8
LUBRICATION SCHEDULE CHART	8-4
Lubrication Table	8-5

M	
MACHINE DESCRIPTION	5
MACHINE DIMENSIONS DD-24 / DD-30	7-10
MACHINE DIMENSIONS DD-28 HF / DD-34 HF	7-11
MACHINE IDENTIFICATION	3
MACHINE WEIGHTS AND FIGURES DD-24 / DD-30	7-6
MACHINE WEIGHTS AND FIGURES DD-28 HF / DD-34 HF	7-8
MAIN FRAME	6
Maintenance	1-9
MAINTENANCE INSTRUCTIONS	5-2
MAINTENANCE SCHEDULE	5-3
METRIC TORQUE CHART	9-3
Miscellaneous Areas	9-4
MOUNTING AND DISMOUNTING OF ATTACHMENTS	4-19
MOVEMENT OF MACHINE BETWEEN WORK SITES	4-19
Moving the Machine (Propulsion Control)	4-12
Multipurpose Grease Properties	8-8

N	
NOTE	1-3

NOTICE	1-3
--------	-----

O	
Operating	1-8
OPERATING INSTRUCTIONS	4-2
Operating Suggestions and Checks While Operating Machine	4-11
OPERATING THE MACHINE	4-11
Operating the Machine Using Manual Vibration	4-15
operational procedures	4-2
ORGANIZATIONAL MEASURES	1-4
OVERVIEW	1-3

P	
Parking the Machine	4-17
PARKING, STOPPING AND SHUTTING DOWN THE MACHINE	4-17
PRE-START CHECK	6-3
PRE-START CHECKS/VERIFICATIONS	4-3
PRE-START INSPECTION	1-5
Prior to cleaning	5-12
Prior to conducting any maintenance work	5-2
PROCEDURE WHEN RECEIVING THE MACHINE	3
Purge Lube Carrier	5-28

R	
Radiator	1-20
Replace The Air Cleaner Elements	5-9
Rollover	1-16, 1-19
ROPS/SEAT BELT	7
Rotating Fan and Belt	1-20
Rotating Fan Blade	1-17
ROUTINE MAINTENANCE - AS REQUIRED	5-5

S	
SAE TORQUE CHART	9-2
SAFETY	1-1
SAFETY INSTRUCTIONS GOVERNING OPERATION	1-5
SAFETY RELATED DECALS	1-15
SCHEMATICS	10-2
Securing the machine to the transporter (Tie-down)	4-19
SELECTION AND QUALIFICATION OF PERSONNEL	1-4
SERVICE FUNCTIONS	8-5
SERVICEABILITY	7
Shutting Down the Machine	4-18
Starting	1-7

SUBJECT INDEX

STARTING MACHINE AND OTHER CHECKS/ VERIFICATIONS	4-8
Stopping	1-9
Stopping the Machine	4-17
SYMBOL IDENTIFICATION	2-2

T

TECHNICAL SPECIFICATIONS	7-2
Torque Loose Bolted Connections	5-12
TORQUE SPECIFICATIONS	9-2
TOWING THE MACHINE	
MODELS DD-24/DD-30	4-20
MODELS DD-28/DD-34HF	4-22
TRANSPORTING, TOWING AND LOADING ..	
1-12	
TROUBLESHOOTING	6-2

U

UNDERSTAND SIGNAL WORDS	1-2
US DECALS	1-16
Using Vibration Controls	4-15
Operating the Machine Using Auto Vibration	4-14

V

Viscosity Temperatures	8-8
Voltmeter Indicates Low Or Negative Value	6-5

W

WARNING	1-3
WARNING OF SPECIAL DANGERS	1-12
WARNINGS	1-3

SUBJECT INDEX

The warranty statement is provided within the manual kit shipped with the machine.

