











MASSTEER[®]
CLIMATE SOLUTIONS
MCS

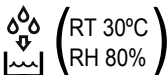

USER AND MAINTENANCE BOOK	en
LIBRETTO USO E MANUTENZIONE	it
BEDIENUNGS- UND WARTUNGSANLEITUNG	de
MANUAL DE INSTRUCCIONES PARA EL USO Y MANTENIMIENTO	es
MANUEL D'UTILISATION ET DE MAINTENANCE	fr
HANDLEIDING VOOR GEBRUIK EN ONDERHOUD	nl
VEJLEDNING OM BRUG OG VEDLIGEHOELSE	da
KÄYTTÖ- JA HUOLTO-OHJE	fi
HEFTE FOR BRUK OG VEDLIKEHOLD	no
ANVÄNDAR- OCH UNDERHÅLLSHANDBOK	sv
INSTRUKCJA OBSŁUGI I KONSERWACJI	pl
РУКОВОДСТВО ПО ЭКСПЛУАТАЦИИ И ТЕХНИЧЕСКОМУ ОБСЛУЖИВАНИЮ	ru
PŘÍRUČKA PRO POUŽITÍ A ÚDRŽBU	cs
HASZNÁLATI ÉS KARBANTARTÁSI KÉZIKÖNYV	hu
PRIROČNIK Z NAVODILI ZA UPORABO IN VZDRŽEVANJE	sl
KNJIŽICA O UPORABI I ODRŽAVANJU	hr
NAUDOJIMO IR PRIEŽIŪROS KNYGELE	lt
LIETOŠANAS UN TEHNISKĀS APKOPES GRĀMATINA	lv
KASUTUS- JA HOOLDUSJUHEND	et
LIVRET DE UTILIZARE SI ÎNTREȚINERE	ro
PRÍRUČKA PRE POUŽITIE A ÚDRŽBU	sk
НАРЪЧНИК ЗА ИЗПОЛЗВАНЕ И ПОДДРЪЖКА	bg
ІНСТРУКЦІЯ З ОБСЛУГОВУВАННЯ	uk
使用和维护手册	zh

DH 752

**ТЕХНИЧЕСКИ ДАНИ - TECHNICKÉ ÚDAJE - TECHNISCHE DATEN - TEKNISK DATA -
 TEHNILISED ANDMED - ESPECIFICACIONES TÉCNICAS - TEKNISET TIEDOT -
 DONNÉES TECHNIQUES - TECHNICAL DATA - TEHNIČKI PODACI - MŐSZAKI ADATOK -
 DATI TECNICI - TECHNINIAI DUOMENYS - TEHNISKIE DATI - TECHNISCHE GEGEVENS
 - TEKNISKE DATA - DANE TECHNICZNE - DADOS TÉCNICOS - INFORMAII TEHNICE -
 ТЕХНИЧЕСКИЕ ДАННЫЕ - TEKNISKA DATA - TEHNIČNI PODATKI -
 TECHNICKÉ PARAMETRE - ТЕХНІЧНІ ДАНІ**

MODEL	DH 752
	220-240 V - В 50 Hz - Гц 810 W - Вт
 (RT 30°C) RH 80%	47,2 l / 24h - л / 24ч
	350 m ³ /h - м ³ /ч
	R410a 0,405 kg - кг
	5÷35 °C
	20÷90 %
	5,7 l - л
	≤52 dB - дБ
	580 x 422 x 820 mm - мм
	30 kg - кг
CO ₂ Eq	0,846
GWP	2088

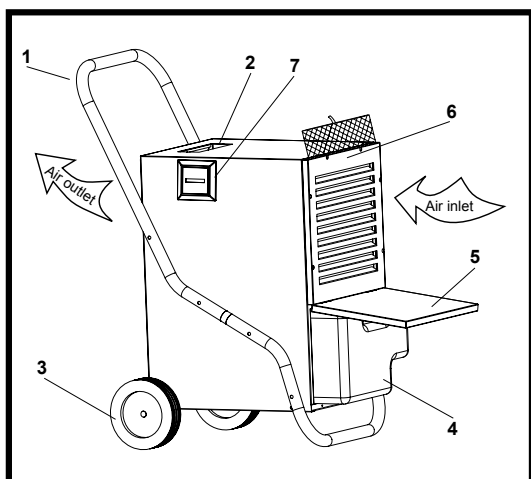

Fig. 1

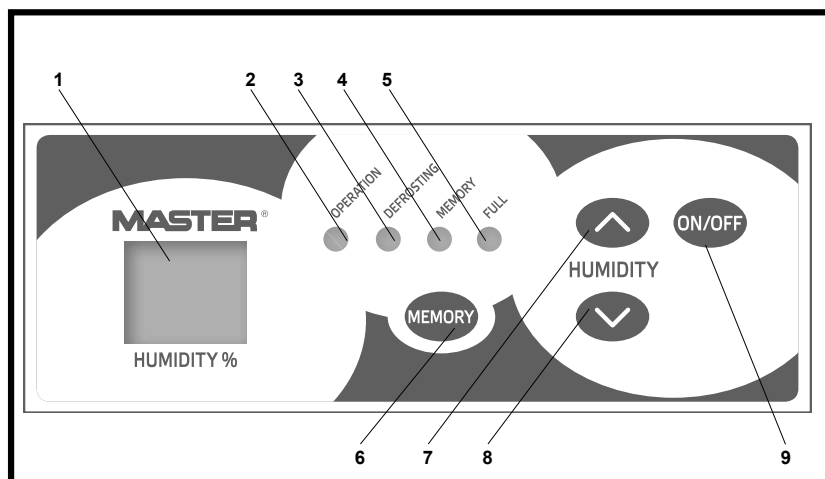

Fig. 2

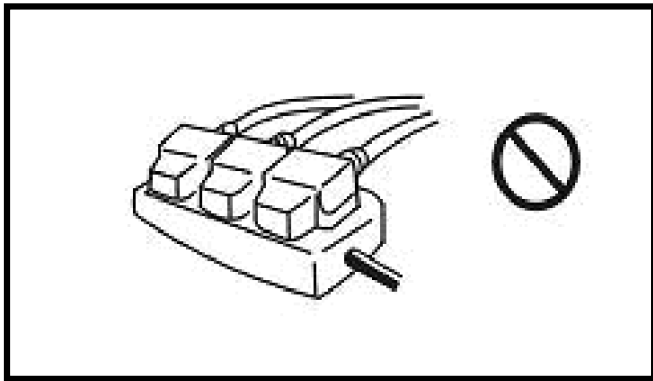

Fig. 3

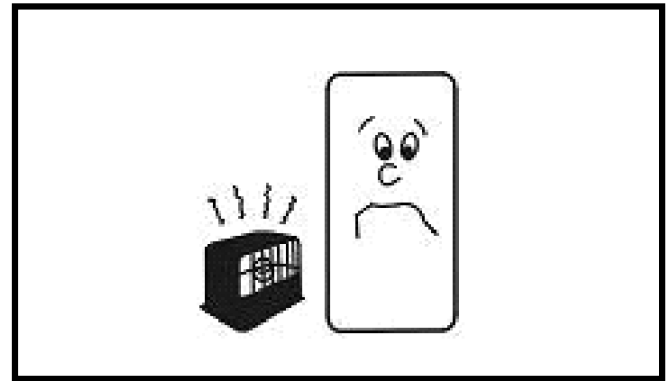

Fig. 4

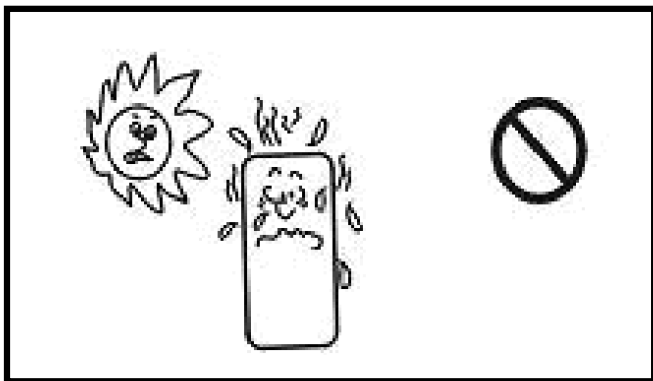

Fig. 5

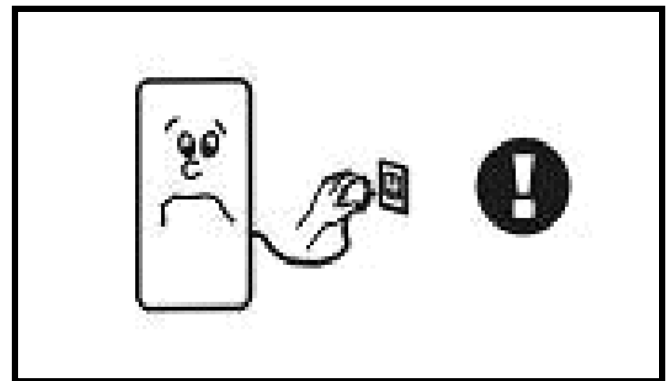

Fig. 6

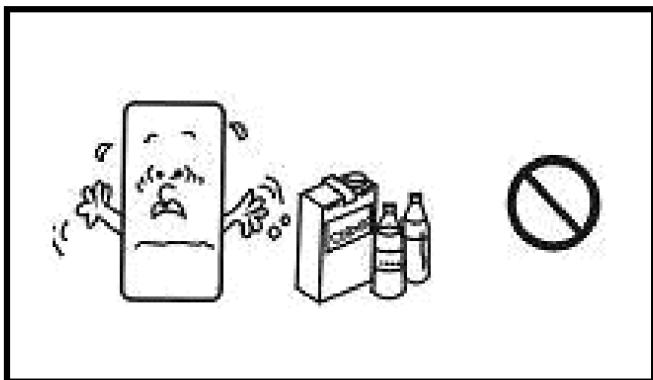

Fig. 7

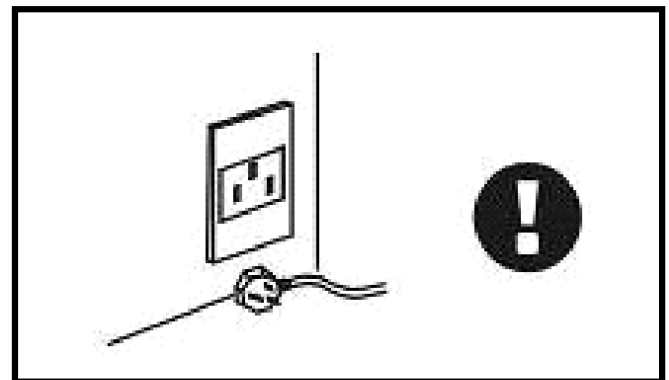

Fig. 8

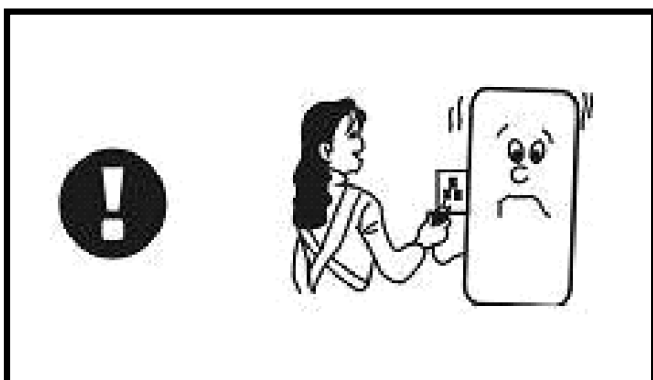

Fig. 9

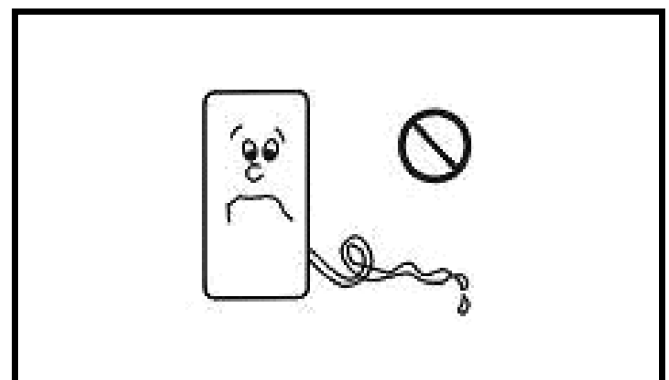

Fig. 10

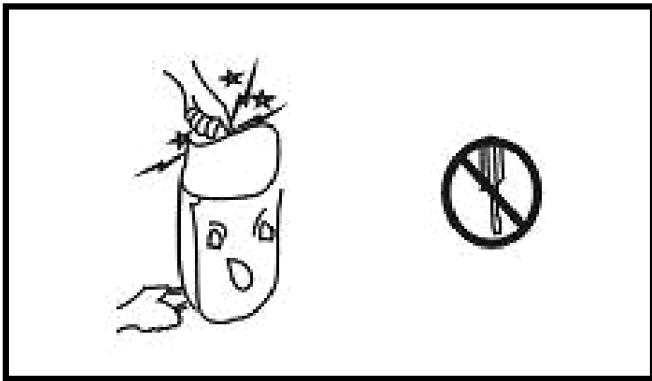

Fig. 11

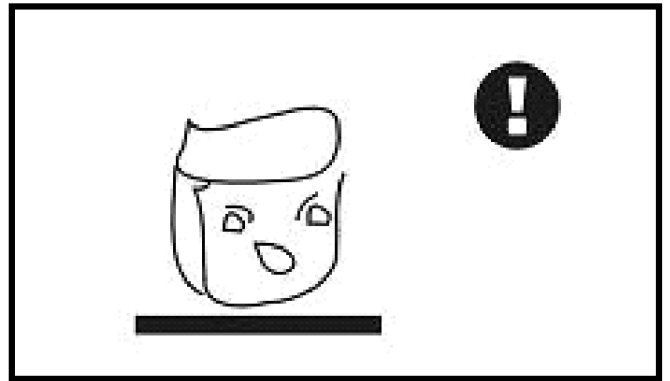

Fig. 12

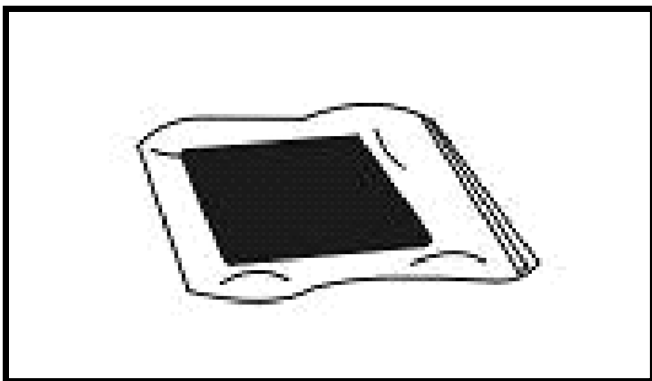

Fig. 13

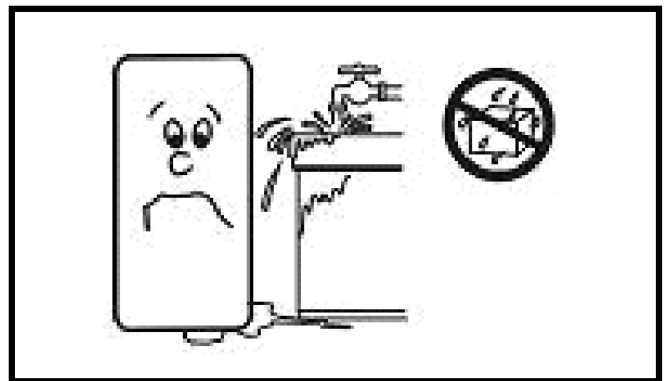

Fig. 14

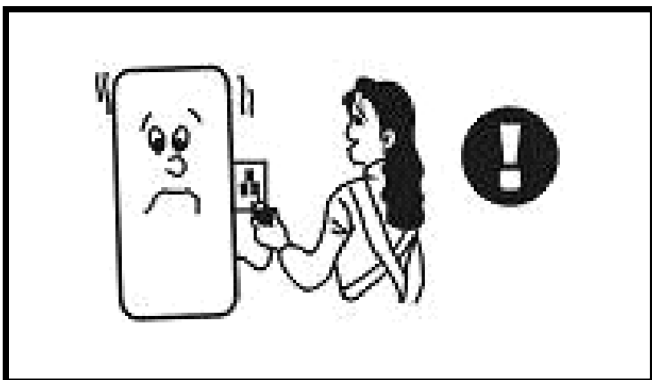

Fig. 15

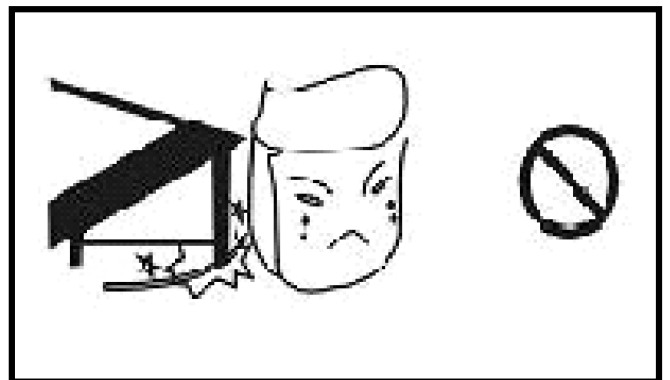

Fig. 16

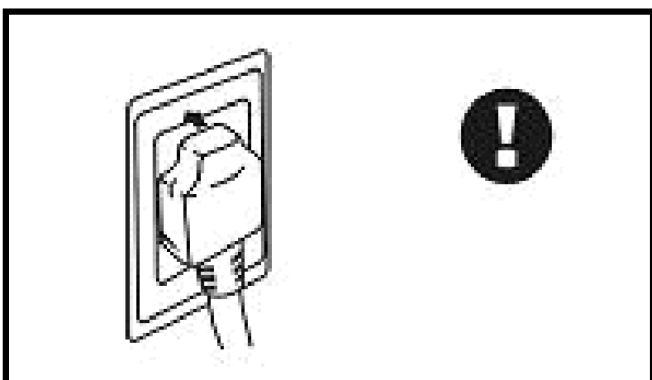

Fig. 17

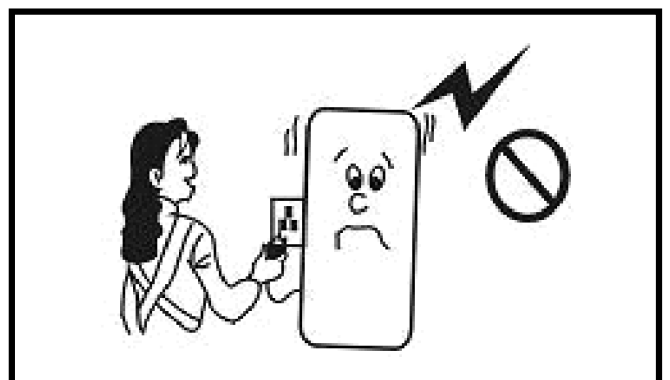

Fig. 18

1...	BEFORE USE
2...	CONSTRUCTION
3...	OPERATION
4...	MAINTENANCE AND SAFETY
5...	NOTICES ABOUT UNIT OPERATION
6...	ELIMINATION DE DÉTÉRIORATIONS

THE UNIT IS SEALED AND CONTAINS FLUORINATED GREENHOUSE GASES COVERED BY KYOTO PROTOCOL. THE "GWP" IS LISTED IN THE "TECHNICAL SPECIFICATIONS TABLE".

▶▶ 1. BEFORE USE

- ▶ please do not cut off the power by pulling the wire
- ▶ please do not plug or unplug to startup or shut off the unit
- ▶ please be careful when moving the unit, do not mangle the wire
- ▶ please do not put fingers or sticks into the grid
- ▶ please prohibit child to climb, stand or sit on the unit
- ▶ please unplug the unit before cleaning or maintenance

NOTICE: WE SUGGEST THAT ANY REPAIRS SHOULD BE EXECUTED BY PROFESSIONAL SERVICEMEN

- ▶ please make sure the unit is grounded
- ▶ please do not use unit in airproof conditions
- ▶ please follow the instructions thoroughly

PRODUCT INTRODUCTION

Dehumidifiers can reduce air humidity in room and thus make people live comfortably and goods stored properly. Due to their neat appearance, compact configuration, high quality and easy operation, our dehumidifiers are widely used in research institutions, industry, transportation, medical centers, measuring institutions, stores, underground constructions, computer rooms, archives, warehouses, bathrooms, etc.

Keeping apparatus, meters, computers, communication equipments, drugs and files away from moisture, eroding, and mildew.

▶▶ 2. CONSTRUCTION

▶ Dehumidifier FIG. 1

1. Handle
2. Control panel
3. Wheel
4. Water tank
5. Water tank panel
6. Filter grill
7. Hour counter

▶ Control panel FIG. 2

1. humidity display
2. operate indicator
3. defrost indicator
4. memory indicator
5. tank full indicator
6. memory
7. humidity up
8. humidity down
9. on/off button

▶▶ 3. OPERATION INSTRUCTION OF KEYS:

▶ ON/OFF: Press ON/OFF, the unit runs in a circulation "ON-OFF-ON".

▶ Humidity up and down: Press "humidity up and down" for once, the set humidity will increase or decrease by 1%. Press the key for 1.5 seconds and the set value will increase or decrease by 1%. Press continuously with the speed 5 points per second.

▶ **Memory Key:** Press the memory key and the memory indicator will light on to start the function of memory when the power cuts off. Press the memory key again; the memory indicator dies to shut off the function of memory when the power is cut off.

START ON:

- ▶ Plug on the unit gives off “di”.
- ▶ Press “ON/OFF”, the running indicator lights on, and the humidity display window lights on to display the previously set humidity. The initial humidity setting is 60% and 3 seconds later the humidity display window lights on to display current humidity.
- ▶ Press humidity up or down key to adjust the humidity needed. If the set humidity is 3% less than current humidity, the unit runs; if the set humidity is 3% more than current humidity, the unit stops running.
- ▶ When set humidity is less than 30%, the unit dehumidifies continuously, and the humidity display window reads “CO”.

SHUT OFF:

- ▶ Press “ON/OFF” when the unit is running, the unit stops running and all indicators die.

NOTICES:

- ▶ When the set humidity is higher than current humidity, the unit will not run.
- ▶ When the tank is full, the tank full indicator lights on, meanwhile, the compressor and the fan motor shut off automatically, and the buzzer gives off “DD” sound. Unless the tank is emptied, the buzzer gives the “DD” sound every 5 minutes. Only after emptying the tank the unit will start running again.
- ▶ When dehumidifying, the fan motor and compressor must be running at least for 3 minutes, once the compressor starts on. It is strongly forbidden to restart the compressor again within 3 minutes after the shut off.
- ▶ When operating in low temperature, the unit judges the system temperature automatically to defrost. When defrosting, the defrosting indicator lights on, the compressor runs but fan motor shuts off automatically.
- ▶ When you press the memory key, the controller will record current humidity even if the power is off. The unit will run under previous mode after power supplied again.
- ▶ The humidity display window shows humidity

from 30% to 90%.

- ▶ Keep the unit unplugged if not used for a long time.

CONTINUOUS DRAINAGE:

- ▶ Take out the tank, open drainage gate at the bottom of tank, connect pipeline, fix the tank back, and pull the pipeline out from the bottom of the machine.

▶▶ 4. MAINTENANCE AND SAFETY

▶ FIG. 3

Do not use any relay, prolonged wire or adaptor. Otherwise, it might result in fire, radiation, or an electric shock.

▶ FIG. 4

Do not put the unit nearby stove or heater. Otherwise parts of unit might melt down or even catch fire.

▶ FIG. 5

Do not use the unit in the direct sunshine, wind or rain. (only for indoor usage)

▶ FIG. 6

In case of any other problems (for example smell of scorch), please shut off the unit and unplug it. Otherwise, it might result in fire, electric shock or other malfunctions.

▶ FIG. 7

Do not use the unit in places easily affected by chemicals. Strong chemicals might damage the unit and cause the leakage.

▶ FIG. 8

Please unplug the unit when not used for a long time.

▶ FIG. 9

When cleaning, shut off and unplug the unit. Otherwise, it might result in an electric shock.

▶ FIG. 10

When draining continuously, put the drainer for smooth drainage. If the ambient temperature is as low as freezing, do not drain continuously.

▶ FIG. 11

Do not repair or disconnect the unit yourself. Otherwise it might result in fire or an electric

▶ FIG. 12

Put the unit stably. If the unit turns over, the water will flow out from the tank and damage the objects nearby. Moreover, because of the damage, it might result in fire or an electric shock

▶ FIG. 13

Make the filter more durable. When off for a long time, seal the filter in a plastic bag.

▶ FIG. 14

Do not use the unit near water. The unit might be damaged when soaked in water, so as to result in fire or electric shock.

▶ FIG. 15

Use the standard electric source of 220-240V/~50Hz. Otherwise it might result in fire or electric shock.

▶ FIG. 16

Do not damage the wire. Do not put anything heavy on the wire or heat or pull the wire. Otherwise it might result in fire or an electric shock.

▶ FIG. 17

Clean the dirt on the plug and fix it tightly. If the plug is not fixed tightly, it might cause an electric shock.

▶ FIG. 18

Do not regard the plug as a switch. Otherwise it might result in fire or an electric shock.

▶▶ 5. NOTICES ABOUT UNIT OPERATION

▶ When moving the unit, do not tilt over 45° to avoid any damaging of the compressor.

▶ The unit should be operated between 5°~32°.

▶ When dehumidifying, because of the heat resulted from the running compressor, the indoor temperature will rise by 1°~3°. Such a reaction should be considered as normal.

▶ When indoor temperature is below 10°, and the ambient absolute humidity is quite low, it is unnecessary to use the machine.

▶ Air inlet and air outlet should be at least 10cm away from the wall.

▶ Try to keep the room closed to enhance the dehumidification effect.

▶ Too much dirt on the filter affects dehumidification, may even result in malfunctioning of it, thus it should be cleaned at least once a month. If there is a great amount of powder in the air, the filter must be cleaned once a week, or even every day. Pull the front panel out and clean the filter. If necessary, you may slightly knock all over the filter, use a vacuum cleaner to remove bigger pieces of dirt or even wash the filter in warm clean water (≤40% with some neutral detergents) and then dry it.

▶▶ 6. TROUBLE-SHOOTING

UNIT DOES NOT WORK

▶ Analysis

1. Power cut
2. Switch off
3. Unplugged
4. Fuse melted
5. Tank full

▶ Solution

1. Power on
2. Switch on
3. Plug on
4. Exchange fuse
5. Empty the tank and replace it

DEHUMIDIFIES IN INADEQUATELY

▶ Analysis

1. Filter choked by dirt
2. Some barrier in air inlet or outlet
3. Door or windows open
4. Refrigerant leakage

▶ Solution

1. Clean the filter
2. Remove the barrier
3. Close the door and windows and seclude from the sunshine
4. Contact the manufacturer or seller

WATER LEAKAGE

▶ Analysis

1. The unit is inclined
2. Drainer choked

► Solution

1. Adjust the unit to be stable
2. Pull out the panel and remove the barrier

STRANGE NOISE**► Analysis**

1. Until instable
2. Filter choked

► Solution

1. Place the unit stably
2. Clean the filter

► When above malfunctions occur and they could not be removed, please contact the supplier or seller, do not disassemble the machine yourself.

► When the unit starts or stops running, it makes certain noises of refrigerating circulation, which should not be considered as a malfunction.

► Hot air coming from the air outlet is normal.

INSTRUCTION ON MALFUNCTION CODES:

The unit analyzes malfunction automatically and displays the code on the humidity window.

MALFUNCTION DISPLAY E1

- Sensor of humidity

MALFUNCTION DISPLAY E2

- Sensor of refrigeration pipeline



CE CONFORMITY CERTIFICATE - DICHIARAZIONE DI CONFORMITÀ CE - EG-KONFORMITÄT SERKLÄRUNG - DECLARACIÓN DE CONFORMIDAD CE - DECLARATION DE CONFORMITE CE - EG-CONFORMITEITVERKLARING - DECLARAÇÃO DE CONFORMIDADE CE - EU-OVERENSSTEMMELSESERKLÆRING - EY-VAATIMUSTENMUKAISUUSVAKUUTUS - CE-SAMSVARSERKLÆRING - EG-FÖRSÄKRAN OM ÖVERENSSTÄMMELSE - DEKLARACJA ZGODNOŚCI WE - ДЕКЛАРАЦИЯ О СООТВЕТСТВИИ CE - PROHLÁŠENÍ O SHODĚ CE - EK MEGFELELŐSÉGI NYILATKOZAT - IZJAVA O SKLADNOSTI IN OZNAKA CE - CE UYGUNLUK BEYANI - IZJAVA CE O SUKLADNOSTI - ES ATITIKTIES DEKLARACIJA - EK ATBILSTĪBAS - DEKLARĀCIJA - EÜ VASTAVUSDEKLARATSIOON - DECLARAȚIE DE CONFORMITATE CE - PREHLÁSENIE O ZHODE CE - ДЕКЛАРАЦИЯ ЗА СЪВМЕСТИМОСТ CE - ДЕКЛАРАЦИЯ ВІДПОВІДНОСТІ CE - IZJAVA CE O PRIKLADNOSTI ΔΗΛΩΣΗ ΣΥΜΜΟΡΦΩΣΗΣ CE - CE 符合性声明

Dantherm Sp. z o.o. - ul. Magazynowa 5A, 62-023 Gądkki, Poland

Product: - Prodotto: - Produkt: - Producto: - Produit: - Product: - Produto: - Produkt: - Tuote: - Produkt: - Produkt: - Produkt: - Produkt: - Изделие: - Výrobek: - Termék: - Izdelek: - Ürün: - Proizvod: - Gaminys: - Ieīce: - Toode: - Produsul: - Výrobok: - Продукт: - Виріб: - Proizvod: - Προϊόν: - 产品:

DH 752

We declare that it is compliant with: - Si dichiara che è conforme a: - Es wird als konform mit den folgenden Normen erklärt: - Se declara que está en conformidad con: - Nous déclarons sa conformité à: - Hierbij wordt verklaard dat het product conform is met: - Declara-se que está em conformidade com: - Vi erklærer at produktet er i overensstemmelse med: - Vakuutetaan olevan yhdenmukainen: - Man erklærer at apparatet er i overensstemmelse med: - Härmed intygas det att produkten är förenlig med följande: - Oświadczam się, że jest zgodny z: - Заявляем о соответствии требованиям: - Prohlašuje se, že je v souladu s: - Kijelentjük, hogy a termék megfelel az alábbiaknak: - Izpolnjuje zahteve: - Aşağıdaki standartlara uygun olduğunu beyan ederiz: - Izjavljuje se da je u skladu s: - Pareiškiame, kad atitinka: - Tiek deklarēts, ka atbilst: - Käesolevaga deklareeritakse, et toode vastab: - Declarăm că este conform următoarelor: - Prehlasuje sa, že je v súlade s: - Декларира се че отговаря на: - Відповідає вимогам: - Izjavljuje se da je u skladu s: - Δηλώνουμε ότι είναι σύμφωνο με: - 兹证明符合:

2014/30/EU, 2014/35/EU, 2011/65/EU

**EN 60335-1:2012+A11:2014+AC:2014,
EN60335-2-40:2003+A11:2004+A12:2005+A1:2006+A2:2009+A13:2012+
AC:2013, EN 55014-1:2006+A1:2009+A2:2011, EN 55014-2:2015,
EN 61000-3-2:2014, EN 61000-3-3:2013, EN 62233:2008+AC:2008**

Gądkki, 01/06/2017

Stefano Verani (Member of the Board)

► en - DISPOSAL OF THE PRODUCT

- This product has been designed and manufactured with top-quality materials and components, which can be re-cycled and re-used.
- When a crossed-wheely bin symbol is attached to the product, it means that the product is protected by the, 2012/19/UE European Directive.
- Please obtain information regarding the local differentiated collection system for electrical and electronic products.
- Respect local Standards in force and do not dispose of old products as normal domestic waste. Correct disposal of the product helps to prevent possible negative consequences for health, the environment and mankind.

► it - SMALTIMENTO DEL PRODOTTO

- Questo prodotto è stato progettato e fabbricato con materiali e componenti di alta qualità, che possono essere riciclati e riutilizzati.
- Quando ad un prodotto è attaccato il simbolo del bidone con le ruote segnato da una croce, significa che il prodotto è tutelato dalla Direttiva Europea 2012/19/UE.
- Si prega di informarsi in merito al sistema locale di raccolta differenziata per i prodotti elettrici ed elettronici.
- Rispettare le norme locali in vigore e non smaltire i prodotti vecchi nei normali rifiuti domestici. Il corretto smaltimento del prodotto aiuta ad evitare possibili conseguenze negative per la salute dell'ambiente e dell'uomo.

► de - ENTSORGUNG DES PRODUKTS

- Dieses Produkt wurde unter Verwendung von Qualitätsmaterialien und -bauteilen entwickelt und hergestellt, die recycelt und wieder verwendet werden können.
- Ist ein Produkt gekennzeichnet durch die Mülltonne mit Rädern und einem Kreuz, wird hier angezeigt, dass dieses Produkt durch die europäische Richtlinie 2012/19/UE überwacht ist.
- Es wird gebeten, sich über die vor Ort bestehende Mülltrennung bezüglich elektrischer und elektronischer Produkte zu informieren.
- Die vor Ort geltenden Vorschriften zur Müllentsorgung müssen eingehalten werden und alte Produkte dürfen nicht zusammen mit dem Hausmüll entsorgt werden. Die ordnungsgemäße Entsorgung des Produkts hilft mögliche negative Folgen für Gesundheit und Umwelt zu vermeiden.

► es - ELIMINACIÓN DEL PRODUCTO

- Este producto ha sido diseñado y fabricado con materiales y componentes de alta calidad que se pueden reciclar y reutilizar.
- Cuando en el producto se encuentra el símbolo del contenedor con las ruedas tachado con una cruz, significa que el producto está tutelado por la Directiva europea 2012/19/UE.
- Se ruega informarse acerca del sistema local de recogida selectiva para los productos eléctricos y electrónicos.
- Respete las normas locales vigentes y no elimine los productos viejos junto con los residuos domésticos normales. La eliminación correcta del producto ayuda a evitar posibles consecuencias negativas para la salud del ambiente y del hombre.

► fr - SE DÉBARRASSER DE VOTRE PRODUIT USAGÉ

- Ce produit a été conçu et fabriqué avec des matériaux et des composants de haute qualité, qui peuvent être recyclés et utilisés de nouveau.
- Lorsque le symbole d'une poubelle à roue barrée est appliqué à un produit, cela signifie que le produit est couvert par la Directive Européenne 2012/19/UE.
- Veuillez vous informer du système local de séparation des déchets électriques et électroniques.
- Veuillez agir selon les règles locale set ne pas jeter vos produits usagés avec les déchets domestiques usuels. Jeter correctement votre produit usagé aidera à prévenir les conséquences négatives potentielles contre l'environnement et la santé humaine.

► nl - VERWIJDERING VAN HET PRODUCT

- Dit product werd ontworpen en gemaakt met hoogwaardige materialen en componenten, die gerecycleerd en herbruikt kunnen worden.
- Wanneer op een product het symbool van de afvalbak op wielen met een kruis erdoor is aangebracht, betekent dit dat het product valt onder de Europese Richtlijn 2012/19/UE.
- Gelieve inlichtingen in te winnen betreffende het plaatselijke systeem voor gedifferentieerde inzameling van elektrische en elektronische toestellen.
- Respecteer de plaatselijke normen die van kracht zijn, en verwijder de oude toestellen niet als gewoon huishoudelijk afval. Een correcte verwijdering van het product helpt om mogelijke negatieve gevolgen voor de gezondheid van mens en milieu te voorkomen.

► pt - ELIMINAÇÃO DO PRODUTO

- Este produto foi projetado e fabricado com materiais e componentes de alta qualidade que podem ser reciclados e reutilizados.
- Quando for afixado em um produto o símbolo do bidão com rodas marcado com uma cruz, significa que o produto é protegido pela Diretiva Europeia 2012/19/UE.
- Solicitamos informar-se sobre o sistema local de recolha diferenciada para os produtos elétricos e eletrônicos.
- Respeitar as normas locais em vigor e não eliminar os produtos antigos como normais detritos domésticos. A correta eliminação do produto ajuda a evitar possíveis consequências negativas para a saúde do ambiente e do homem.