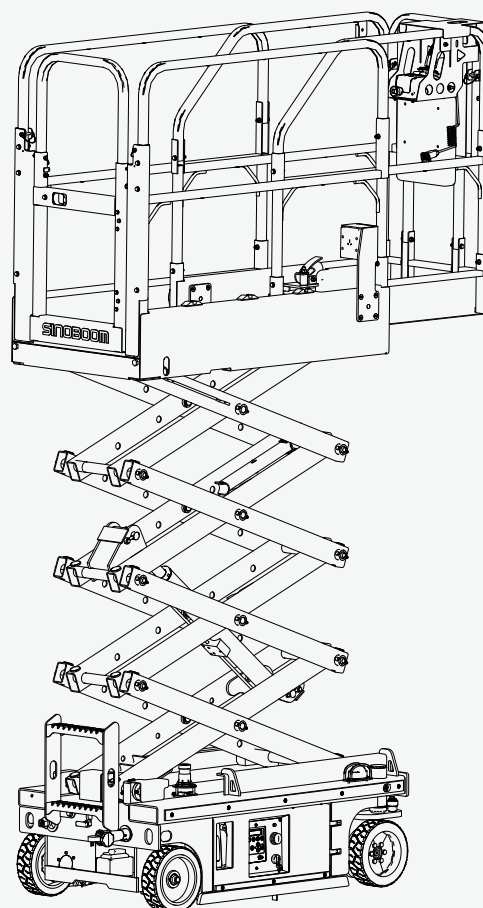


Manual No: 501072110002-EN
Manual Version: B
November 2023
Translated version

Maintenance Manual

0407SE/1530SE



CE GB ANSI SFA®

SINOBOOM



WARNING

Operating, servicing and maintaining this vehicle or equipment can expose you to chemicals including engine exhaust, carbon monoxide, phthalates and lead, which are known to the State of California to cause cancer and birth defects or other reproductive harm. To minimize exposure and avoid breathing exhaust, do not idle the engine except as necessary, service your vehicle or equipment in a well-ventilated area and wear gloves or wash your hands frequently when servicing. For more information, go to: www.P65warnings.ca.gov.

For disposal, please comply with local regulations.

SINOBOOM



星邦智能

星邦

All of the above are registered trademarks of **Hunan Sinoboom Intelligent Equipment Co., Ltd.**

Contact us:

Website:www.sinoboom.com.cn/www.sinoboom.com

Sales Tel:+86 400-601-5828/+86-0731-87116222

Service Tel:+86 400-608-1289/+86-0731-87116333

E-mail:info@sinoboom.com/sales@sinoboom.com

Address: No.128, East Jinzhou Avenue, Ningxiang High-tech Industrial Park, Changsha, Hunan, China

Postal code:410600

Copyright©Hunan Sinoboom Intelligent Equipment Co., Ltd.

Hunan Sinoboom Intelligent Equipment Co., Ltd. retains the right of final interpretation of the manual.

To Users

Thank you for choosing and using the machinery of **Hunan Sinoboom Intelligent Equipment Co., Ltd.**

Use this machine only to transport tools to work locations and for performing tasks on the work platform. Only authorized personnel who have received appropriate MEWP training may operate this machine. Before using the machine, carefully read and fully understand this manual and strictly follow its relevant instructions. Different countries, regions, or governments may have equipment operating regulations that conflict with this manual. The stricter safety operating regulations should be followed. Our company will not be liable for any adverse consequences arising from the failure to operate and use the machine in accordance with this manual or other relevant regulations.

This manual provides necessary safety precautions and maintenance instructions for users. This manual covers the basic configuration information of one or more models. Please refer to the information applicable to your machine model. Treat this manual as an integral part of the machine and keep it with the machine at all times. This manual may not be copied, distributed, sold, or altered without written permission from Sinoboom.

Due to continuous improvement and upgrading of product design and different product models covered, some charts and textual content in the manual may be not applicable to your machine. Our company reserves the right to revise the contents of this manual due to technological improvements. Changes will be made without prior notice. Contact Sinoboom to obtain the most current version of the manual.

Please go to www.sinoboom.com.cn to download your desired Operation Manual, Maintenance Manual and Parts Manual.

If you have any questions, contact **Hunan Sinoboom Intelligent Equipment Co., Ltd.**

Applicable Models

The manual applies to the following models and serial numbers:

Model	Metric Trade Name	Imperial Trade Name	Serial No.
0407SE	0407SE	1530SE	0107213868 to present

Note:

- Check the machine model and serial number on the machine nameplate. The location of the nameplate can be found in the **Decals Diagram** section of the Operation Manual.
- Product model numbers are indicated on the nameplates to distinguish products with different main technical parameters.
- Product trade names (product commercial codes) are used for marketing purposes and machine decals for the differentiation of products with different main technical parameters. Product trade names are categorized as metric and imperial trade names: metric trade names are applicable to regions/countries using the metric system or as specifically requested by customers; imperial trade names are applicable to regions/countries using the imperial system or as specifically requested by customers.

CONTENTS

1 Safety Warning Symbols and Signs	1	Pre-delivery Inspection (PDI)	23
2 Maintenance Safety		Pre-operation Inspection	23
Precautions	5	Regular Inspections	23
2.1 General	5	Annual Inspection.....	23
2.2 Instructions before Maintenance ..	5	Preventive Maintenance	23
Requirements for Maintenance		Responsible Persons and Quali-	
Personnel.....	5	fications for Performing Inspection	
Precautions before Maintenance	5	and Maintenance	24
2.3 Maintenance Safety.....	6	Inspection and Preventive Mainte-	
2.4 Considerations After		nance Schedule	24
Maintenance	10		
3 Technical Characteristics 11		4.2 General Maintenance	
3.1 Machine Specifications	11	Instructions.....	27
3.2 Function Speed	13	4.3 Major Modification and Repair ...	31
3.3 Specifications of Major			
Components	14	5 Platform Components.....	33
Drive Reducer	14	5.1 Platform Controller	33
Power Unit.....	14	5.2 Platform Assembly	33
Battery	14	5.3 Platform Extension.....	34
3.4 Weight of Major Components	15		
3.5 Pressure Settings	16	6 Scissor Arms	
3.6 Oil Requirements	16	Components.....	35
3.7 Torque Specifications	16	6.1 Disassembly and Installation.....	35
Special Torque Requirements	16	6.2 Safety Strut	36
Fastener Torque Specifications.....	17	6.3 Lift Cylinder	36
Hydraulic Hose Torque	18		
Hydraulic Fitting Torque	19	7 Chassis Component	37
4 Maintenance Instructions 23		7.1 Travel Drive and Steering Device	37
4.1 Inspection and Preventative		Drive Motor and Reducer	37
Maintenance Schedule.....	23	Steering Cylinder	38
		7.2 Tire Assembly	38
		Checking Tires and Rims	38
		Checking Wheel Nuts.....	38
		Replacement Requirements.....	39
		Replacing Tire and Wheel Assembly	39
		7.3 Chassis Wear Pads	39

7.4	Power Unit	40	11.3	Brake Function.....	73
7.5	Battery	40	11.4	Pothole Protection Device	74
8	Hydraulic System	41	11.5	Tilt Protection Function	74
8.1	Function Valves	41	11.6	Overload Limit Function.....	74
8.2	Power Unit	44	11.7	Staged Lowering Function	75
	Function Valves.....	45	11.8	Emergency Lowering Function..	75
	Hydraulic pump	46	12	Control System.....	77
	Hydraulic Tank	46	12.1	Sinoboom Main Control Sys-	
8.3	Hydraulic Oil	47		tem (Wide Panel).....	77
	Checking Oil Level.....	47		System Interface.....	77
	Checking the Cleanliness of the			Updating the Program	80
	Hydraulic Oil	47		Checking the Program Version	80
	Changing the Hydraulic Oil	47		Query Interface	80
8.4	Adjusting Emergency Lowering			Brake Release	80
	Handle	48		User Selection Setting	80
8.5	Lubricating Oil Cylinder	48		Parameters Setting	82
8.6	Cylinder Drift Inspection.....	48	12.2	DTC-K500 Main Control System	83
8.7	Hydraulic Symbols	49		System Interface.....	83
8.8	Hydraulic Schematic Diagram ...	50		Checking the Program Version	85
9	Electrical System.....	51		Updating the Program	85
9.1	Battery	51		Set Speed	85
	Inspection.....	51		Set Option	85
	Adding Fluid	52		Brake Release	85
	Equalization	52		Calibration Setting	85
	Storage	52		Machine Mode Setting.....	86
9.2	Changing the Charging Curve ...	53		Check Fault History.....	87
9.3	Electrical Symbols	54	13	Appendix.....	89
9.4	Electrical Schematic Diagram....	56	13.1	Major Modification and Repair	
10	Troubleshooting Guide .59			Record	89
10.1	Fault Codes Description	59	13.2	Inspection and Preventive	
	Machine Faults and Solutions	59		Maintenance Schedule.....	90
	Charging Faults and Solutions.....	70			
10.2	Basic Troubleshooting	70			
11	Functions and Controls.73				
11.1	Machine Positions	73			
11.2	Drive Function	73			

1 SAFETY WARNING SYMBOLS AND SIGNS

The safety warning symbols used on the machine and in the manuals have the following meanings:



Safety warning symbol. This symbol is used to alert you to potential hazards. Observe all safety instructions following a symbol to avoid possible injuries.

DANGER

Indicates an imminently hazardous situation that, if not avoided, will result in death or serious injury.

WARNING

Indicates an imminently hazardous situation that, if not avoided, could result in death or serious injury.



















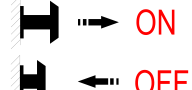
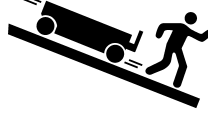

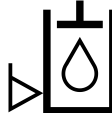
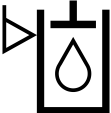


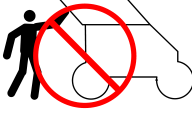
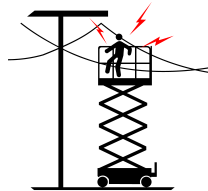
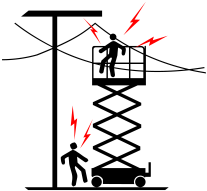
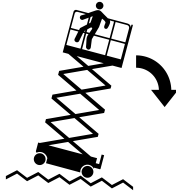
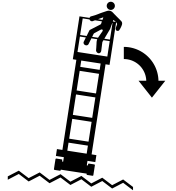
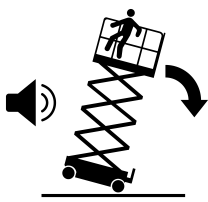
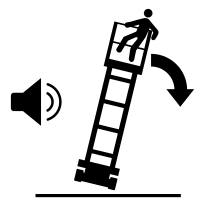

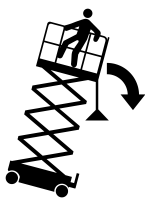

CAUTION

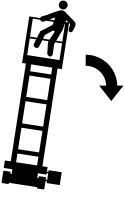

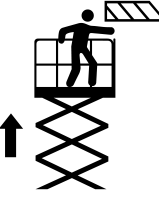
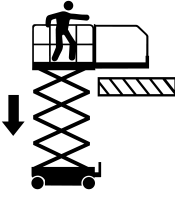
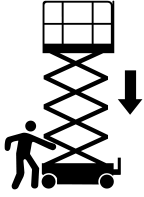
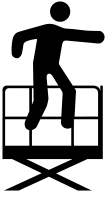

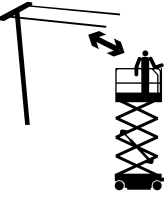
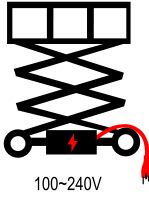
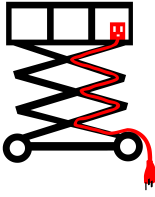
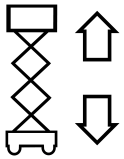
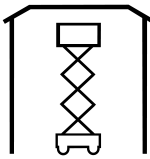
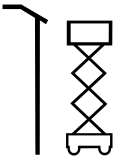
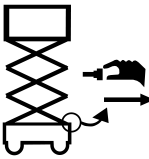

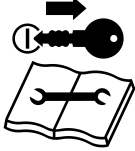







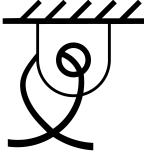


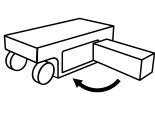



Indicates an imminently hazardous situation that, if not avoided, could result in minor or moderate injury.


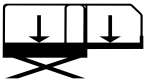
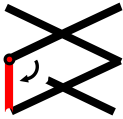
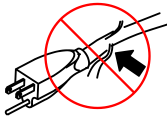
NOTICE

Indicates information directly or indirectly related to personal safety, machine damage, or property loss.

The safety signs used on the machine and in the manuals have the following meanings:

 Refer to the Maintenance Manual	 Anchor point only for 1 person	 Wind speed	 Chemical burns hazard	 Wedge the wheel
 Refer to the Operation Manual	 Add lubricant	 Crushing hazard – safety shoes required	 Danger of hot, high-pressure fluid spray	 Wind
 Press the directional-control valve	 Repeatedly operate the manual brake release valve	 Release the brake	 Alarm sounding	 Horn
 Noise level	 Burn hazard	 Keep a safe distance from high temperatures	 Pull out-ON Press-OFF	 Collision hazards - never release the brake on slope
 Hydraulic oil filler	 Hydraulic oil level low	 Hydraulic oil level high	 Temperature	 Replace with tires of the same specification
 Only trained maintenance personnel can check the compartment	 Electrocution hazard on platform	 Electrocution hazard on the ground and platform	 Tipping hazard – avoid uneven ground	 Tipping hazard – avoid uneven ground
 Tipping hazard – never use machine in strong, gusty winds	 Tipping hazard – never use machine in strong, gusty winds	 Tipping hazard – never push or pull objects outside the platform	 Tipping hazard – never suspend objects from the platform	 Tipping hazard – never place ladders and scaffolding on the platform

 <p>Tipping hazard – never leave the door open</p>	 <p>Collision hazard – keep head clear of overhead obstacles when raising platform</p>	 <p>Crushing hazard – keep hands clear from overhead obstacles when raising platform</p>	 <p>Collision hazard – keep the platform clear of obstacles below when lowering the platform</p>	 <p>Crushing hazards – keep hands away from scissor arms when lowering the platform</p>
 <p>Fall hazard – never climb on platform guardrails</p>	 <p>Fall hazards – never climb on scissor arms</p>	 <p>Keep a safe distance from power lines</p>	 <p>Battery charging plug</p>	 <p>Platform power plug</p>
 <p>Platform up and down movement</p>	 <p>Indoor use</p>	 <p>Outdoor use</p>	 <p>Emergency lowering handle position</p>	 <p>Maximum platform height</p>
 <p>Only qualified maintenance personnel may perform maintenance work</p>	 <p>Wear protective clothing and safety goggles</p>	 <p>Lateral force</p>	 <p>Electrocution hazard</p>	 <p>Battery explosion hazard</p>
 <p>No smoking or open flames/sparks</p>	 <p>No smoking or open flames/sparks</p>	 <p>Lifting point</p>	 <p>Lashing point</p>	 <p>Tire ground pressure</p>
 <p>Forklift pocket position</p>	 <p>Close the chassis door</p>	 <p>Tool or weight</p>	 <p>Fast/high speed</p>	 <p>Slow/low speed</p>

 <p>Platform load capacity</p>	 <p>Respective load capacity of main platform and platform extension</p>	 <p>Engage the safety strut</p>	 <p>Do not use damaged power cables</p>	
---	---	--	---	--

2 MAINTENANCE SAFETY PRECAUTIONS

2.1 GENERAL

This chapter covers safety precautions that must be taken when servicing the mobile elevating work platform. Before carrying out any repair work, maintenance personnel must carefully read and understand all warnings and precautions, and follow the instructions in this manual when performing maintenance on the mobile elevating work platform.

WARNING

It is forbidden to alter or modify the machine without the written permission of Hunan Sinoboom Intelligent Equipment Co., Ltd.

2.2 INSTRUCTIONS BEFORE MAINTENANCE

Requirements for Maintenance Personnel

Maintenance personnel is responsible for maintaining the machine so that it can be operated safely and normally. Before performing inspection and maintenance work on this machine, maintenance personnel should read, understand and comply with all applicable regulations and requirements of employers, local authorities, and governments related to the operation of this machine. Maintenance personnel must also read and fully understand this manual.

Maintenance personnel shall:

- obtain appropriate qualification and authorization
- be experienced professional technicians or engineers
- be familiar with the machine and its associated risks
- receive appropriate training, including but not limited to training on the use of special equipment
- be familiar with the safety precautions and related operating procedures for maintenance work on this machine.

NOTICE

- *Only authorized personnel who have received appropriate training and obtained qualifications may repair this machine.*
- *Individuals who have consumed alcohol or medication, who experience physical or mental fatigue or are unwell may not carry out any work on the machine.*

Precautions before Maintenance

Before and during inspection and maintenance procedures personnel shall use caution and take measures to avoid dangerous situations. Those measures include, but are not limited to, the following:

1. Always park the machine on level, firm ground for maintenance, and ensure that the maintenance area is clean and unobstructed.
2. Choose appropriate safety equipment.
 - Maintenance personnel must identify risks in conjunction with inspection and maintenance work, and select appropriate safety equipment that is suitable for the type of work and the work place conditions, such as safety helmets, protective masks, protective gloves, goggles, protective clothing, safety belts and safety shoes.
 - Before carrying out inspection and maintenance work, check that the safety equipment is in good condition and is used correctly.
 - Safety equipment must be inspected regularly and needs to be replaced in case of damage.
3. Choose appropriate repair tools.
 - Before conducting any inspection and/or maintenance work, maintenance personnel shall prepare appropriate tools as required for the type of work, such as wrenches, screwdrivers, pliers, multimeter, pressure gauge, lubrication device, jack and lifting equipment.
 - Verify that the load capacity of jacks or lifting equipment is suitable for the planned task. Refer to the **Weight of Major Components** section to select a device with sufficient load capacity.
 - Service tools must be kept clean and in good condition.

4. Lock the wheels once the machine is parked to prevent it from moving inadvertently.
5. Do not perform inspection and/or maintenance work after the machine has been started.
 - Before performing inspection and/or maintenance work, make sure the machine is turned off, and remove the key. An “Out of Service” warning sign can be placed next to the ground controls and platform controls, or the main power switch can be pressed to prevent unrelated personnel from inadvertently starting the machine.



2.3 MAINTENANCE SAFETY


 WARNING
Inadvertently starting the machine during inspection or maintenance may cause machine damage and/or personal injury.

- If inspection or maintenance work must be carried out while the machine is running at least two people should work together. One person must be close to the turntable control panel or platform control panel so as to be able to turn off the machine any time if necessary while a second person carries out inspection or maintenance work, both persons shall maintain close contact with each other at all times.
6. Before carrying out maintenance work on electrical components always press (shut off) the main power switch.
 7. The machine should be cleaned before carrying out inspection and/or maintenance work. Avoid letting dust or debris enter internal machine components during the maintenance process, as this can affect the machine's performance.

The above listed requirements must be adhered to strictly during maintenance/inspection work. In addition, all other appropriate measures must be taken to ensure safety during maintenance work, taking account of the working environment.

Unsafe Maintenance Hazards

 WARNING	
	<ul style="list-style-type: none"> • Before performing any adjustment or service operations, power off all control units and ensure that all moving parts are safely secured and cannot move unintentionally. • Before performing any adjustment or service operations, ensure that the scissor arms are stowed, and do not carry out maintenance with the scissor arms raised. If maintenance must be carried out with the scissor arms raised, take appropriate protective measures to avoid dangerous conditions. • When lifting or moving heavy parts of the machine, use equipment with sufficient capacity, and never place heavy objects in unstable positions after moving. • When machine parts are lifted by other equipment, ensure that there are no persons under and/or around the equipment. • When striking brass rods with a mallet, make sure to wear eye protection. • If you need to replace parts, use only original parts specified by Sinoboom. • Do not wash the machine with water. The machine contains electronic components such as solenoid valves and sensors, which may fail or operate erratically after water ingress. If it is necessary to wash with water, turn off the main power switch before proceeding. Only turn the power back on after ensuring the machine is completely dry. • Make sure the machine is turned off before using flushing equipment (such as a high-pressure water gun) to clean the machine. Do not direct water or steam ejected from the flushing equipment at electrical components, as this may cause short-circuits or electrical shocks. • After maintenance is completed, thoroughly clean up any spilled

 WARNING
<p>hydraulic oil, and avoid allowing it to be spilled on the ground.</p> <ul style="list-style-type: none"> • After maintenance is completed, immediately wash off any hydraulic oil that may have come into contact with your skin. • Waste hydraulic fluids, fuels, coolants and refrigerants must be recycled or disposed as per local regulations.

High Temperature and High Pressure Hazards

WARNING

- While the machine is in operation or after running for a period of time, components may generate high surface temperatures, which can cause burns upon contact. Do not touch any hot parts!
- It is forbidden to repair or tighten hydraulic hoses or seals while the machine is operating or when the oil system is under pressure.
- Before loosening or disassembling hydraulic parts (especially the counterbalance valve on the cylinder), the hydraulic pressure of all hydraulic lines should be released and the hydraulic oil should completely cool down.
- For engine-powered machines, do not attempt to open the radiator cover while it is hot.
- Disassemble the hydraulic components slowly to prevent the hydraulic oil from splashing and causing injuries.
- Never check for hydraulic leakages by hand. Use a piece of cardboard or stiff paper to locate leaks, and wear gloves to protect your hands from spraying hydraulic fluid.
- Do not operate the machine in case of hydraulic or air leaks. Oil or air leakage from the hydraulic system may penetrate and burn the skin.
- Never plug hydraulic leaks by hand. If there is a leak, the pressure of the hydraulic system should be released first, maintenance/repair should be carried out after the hydraulic oil has cooled down.
- If injury occurs due to high temperature and/or high pressure, seek immediate medical attention. If treatment is not carried out immediately, serious complications may result.

Welding and Grinding Operation Hazards

WARNING


- Welding, grinding and polishing operations must follow the appropriate local safety procedures.
- Before performing welding, grinding and polishing operations, turn off the machine's power, and ensure that all wires or cables are connected correctly.
- Do not use the machine as a ground wire during welding and grinding operations.
- Always make sure that all power tools are placed completely within the perimeter of the platform. Do not hang the cords of power tools on the guardrail of the platform or in any work area outside the platform, and do not hang the power tools directly by their cords.






Fire and Explosion Hazards


WARNING

- Do not operate the machine, charge the battery or refuel the machine in places where potentially flammable or explosive gases may be present.
- Refueling and charging should be carried out in a well-ventilated place without flames, sparks, and other hazards that may cause fire or explosion.
- For engine-powered machines, do not refuel the machine while the engine is running.
- Never spray ether or other starting agents into glow-plug-equipped engines (engine-powered machines).
- Never touch the battery terminals or cable clamps with tools that can generate sparks.
- Only approved non-flammable cleaning solutions should be used on the machine.

Battery Hazard


 **WARNING**


- 
 - Be sure to read and adhere to the battery manufacturer's recommendations on proper battery use and maintenance procedures.
- 
 - Individuals without adequate professional qualification should not repair and maintain the battery system, otherwise this may cause personal injury or damage to the battery system.
- 
 - Individuals without adequate professional qualification should not modify parameters, signal lights, etc. during the operation of the battery system, otherwise this may cause personal injury or damage to the battery system.
- 
 - Always wear goggles, protective gloves and protective clothing, and remove all rings, watches and other accessories before servicing the battery. Contact with live circuits may result in death or serious injury.
- 
 - Before replacing the battery, be sure to select an appropriate number of personnel and suitable lifting methods.
- It is forbidden to modify the battery system without approval to avoid serious accidents.
- When maintaining electrical components, the battery should be disconnected.
- Do not place tools or other metal objects across the two terminals of the battery.
- The battery charger can only be connected to a grounded three-wire AC power outlet. Make sure the charger is working properly before charging. Do not connect the battery directly to a power outlet.
- If the battery becomes hot, deformed, leaks, emits an unusual smell, or produces smoke during use, stop using the battery immediately and report to the relevant maintenance personnel promptly.
- Batteries contain sulfuric acid and can produce explosive

 **WARNING**

mixtures of hydrogen and oxygen. Keep any materials (including cigarette/smoking materials) that can cause sparks or flames away from batteries to prevent explosion.

- Never touch the battery terminals or cable clamps with tools that can generate sparks.
- Never charge the battery in direct sunlight. The battery should be charged in a well-ventilated place.

 **CAUTION**



- Avoid spilling battery acid or allowing it to come into contact with unprotected skin. If battery acid spills, use water mixed with bicarbonate (baking soda) to neutralize the acid. In case of contact with battery acid, rinse the acid off immediately with plenty of water and seek medical attention promptly.

- Always keep the battery upright. If the battery is placed on its side or at an angle, liquid may spill from the battery.
- Discarded batteries can be hazardous, and must not be treated like regular waste. If you need to discard them, please contact a battery recycling company.

NOTICE



- Please use the charger provided by the manufacturer to charge the battery.
- The charging process must be completed in full. Frequent intermittent charging can damage the battery.
- The battery is only suitable for use with the equipment it was provided with at the time of manufacture. Do not use the battery for other purposes.
- Do not reverse the positive and negative terminals of the battery for use.
- Do not short-circuit the positive and negative terminals of the battery system.
- Do not place objects or tools on the battery to prevent short circuiting it.
- Do not strike, throw, step on, or hit the battery with sharp objects.
- Do not immerse the battery in water, acidic, alkaline or salty solutions, and protect the battery from rain.
- The battery should be fully charged immediately after each use of the machine, then the machine power switch should be turned off.

2. After maintenance, all maintained parts must be checked for abnormal operation, oil leakage, loose bolts and other problems.
3. The safety protective device needs to be restored or reinstalled, and if necessary, be recalibrated.
4. After maintenance, clear up the tools and equipment for maintenance, remove the replaced parts and loose objects, and clean up the site.
5. Record inspections and maintenance as required.

NOTICE

All maintenance work must include a verification that the machine is operating properly.

WARNING

- Waste liquids must not be dumped or disposed of randomly. Waste liquids shall be discharged into appropriate containers.
- Waste hydraulic fluids, fuels, coolants and refrigerants must be recycled or disposed as per local regulations.

NOTICE

Battery over-discharge (continued use of battery with level of less than 10%) or battery under-voltage caused by long-term non-charging (battery with level of less than 10% not charged for more than three days), resulting in battery capacity attenuation and failure, are not covered by the warranty.

2.4 CONSIDERATIONS AFTER MAINTENANCE

1. Check the machine functions so that faults such as oil leakage or poor operation can be detected as early as possible.

3 TECHNICAL CHARACTERISTICS

3.1 MACHINE SPECIFICATIONS

Table 3-1

Item	Metric	Imperial
Product Category		
Battery type	Maintenance-free lead-acid battery	
Travel drive type	DC motor	
Dimensions		
Maximum platform height (indoor/ outdoor)	4.5 m/3.8 m	14 ft 9.2 in/ 12 ft 5.6 in
Maximum working height (indoor/ outdoor)	6.5 m/5.8 m	21 ft 3.9 in/19 ft
Maximum horizontal reach	0.6 m	2 ft
Overall length	1.42 m	4 ft 7.9 in
Overall width	0.76 m	2 ft 5.9 in
Overall height (stowed, guardrail folded)	1.67 m	5 ft 5.8 in
Overall height (stowed, guardrail unfolded)	1.97 m	6 ft 5.6 in
Wheelbase	1.11 m	3 ft 7.7 in
Track width	0.7 m	2.2 ft
Ground clearance (pothole guard retracted)	0.061 m	2.4 in
Ground clearance (pothole guard extended)	0.02 m	0.75 in
Platform dimensions (L×W×H)	1.34 m×0.7 m×1.1 m	4 ft 4.8 in×2 ft 3.6 in×3 ft 7 in
Performance		
Rated platform capacity	240 kg	529 lb
Rated platform extension capacity	115 kg	254 lb
Maximum number of occupants (indoor/outdoor)	2 persons/1 person	
Drive speed (stowed)	0 ~ 4 km/h	0 ~ 2.5 mph
Drive speed (raised)	0 ~ 0.8 km/h	0 ~ 0.5 mph
Platform lifting time (unloaded)	20 ~ 23 s	
Platform lowering time (unloaded)	25 ~ 27 s	
Gradeability (2WD)	25%	

Table 3-1 (continued)

Item	Metric	Imperial
Maximum allowable inclination (front-rear/left-right)	3°/1.5°	
Turning radius (inside)	0.3 m	12 in
Turning radius (outside)	1.35 m	4 ft 5 in
Tire size (diameter×width/type)	Φ255×76 mm/solid	Φ10×3 in/solid
Maximum operating noise level	72 dB	
IP rating	IP 54	
Maximum total vibration on the platform	2.5 m/s ²	
Maximum whole body vibration value (WBV)	0.5 m/s ²	
Power		
Drive x steer	2 WD × 2 WS	
Power unit motor (voltage/power)	24 V DC, 2.2 kW	
Hydraulic tank volume	4 L	0.9 gal (Imperial)/1.05 gal (US)
Hydraulic system pressure	19 MPa	2756 psi
Battery specifications (voltage, capacity, discharge time) – lead-acid battery	24 V, 120 Ah, 20 hr	
System voltage	24 V DC	
Control voltage	24 V DC	
Charger (input voltage/output current)	100 – 240 V AC/15 A	
Drive motor (voltage/power)	24 V DC/0.4 kW	
Weight		
Gross weight	880 kg	1941 lb
Ground bearing data		
Maximum tire load	500 kg	1102 lb
Ground pressure	1000 kPa	145 psi
Environment		
Maximum allowable lateral force (indoor/outdoor)	400 N/200 N	90 lbf/45 lbf
Maximum allowable wind speed (indoor/outdoor)	0 m/s/12.5 m/s	0 mph/28 mph
Maximum allowable altitude	1000 m	3280.8 ft
Allowable ambient temperature range (lead-acid battery)	-10° C to 40° C	14 °F to 104 °F
Allowable ambient temperature range (lithium battery)	-20° C to 40° C	-4° F to 104° F

Table 3-1 (continued)

Item	Metric	Imperial
Maximum allowable relative humidity	90 %	
Storage environment	Store at -20°C to 50°C (-4°F to 122°F) in a well-ventilated environment with 90% relative humidity (max.) (20°C [68°F]), protected from rain, sun, corrosive gas, flammable or explosive materials.	

Note:

- a) The platform height plus the operator height (assumed to be 2 m/6 ft 7 in) equals the working height.
- b) In different areas, hydraulic oil, engine oil, coolant, fuel and lubricant should be added in accordance with the ambient temperature.
- c) In cold weather, auxiliary devices are needed to start the machine.
- d) The ground bearing data is approximate, without considering different options. thus it is applicable only when taking an adequate safety factor into account.
- e) Rated platform load capacity refers to the maximum allowable load on the platform, including the weight of persons, materials, tools, accessories and other objects.
- f) The hydraulic tank capacity is the maximum volume of the tank.
- g) It's recommended not to use the lead-acid battery under the ambient temperature below 0°C, otherwise the battery capacity will decay rapidly and the battery life will be affected.

3.2 FUNCTION SPEED

Table 3-2

Item	Parameter
Raise the platform	25 – 30 s
Lower the platform	30 – 35 s
Travel in high gear – stowed	24.5 – 30 s
Travel in low gear – stowed	49 – 60 s
Travel – operating	123 – 150 s
Braking distance	S≤0.4 m (1.31 ft)

- a) The function speed depends on the start and end point of the movement rather than the controls/ switches.
- b) The drive speed test results will vary with tires of different specifications.
- c) All speed tests should be conducted from the platform controller. Test results will differ if tested from the ground controller.
- d) All tests should be conducted with the hydraulic oil temperature higher than 20 - 30 °C (68 - 86 °F). If the hydraulic oil temperature is too low, the test results will be affected.

Test requirements:

Raise the platform: With the platform unloaded, raise the platform (with the scissor arms from fully retracted position to fully raised position). Perform this maneuver for two times.

Lower the platform: With the platform unloaded, lower the platform (with the scissor arms from fully raised position to fully retracted position). Perform this maneuver for two times.

Travel in high gear – stowed: With the machine stowed on a level surface, switch to high gear, and push the travel joystick to the maximum travel distance to drive the machine forward and reverse for 30 m (98.4 ft) respectively for two times.

Travel in low gear – stowed: With the machine stowed on a level surface, switch to low gear, and push the travel joystick to the maximum travel distance to drive the machine forward and reverse for 30 m (98.4 ft) respectively for two times.

Travel – operating: With the machine operating on a level surface, push the drive joystick to the maximum forward position to drive the machine forward and reverse for 30 m (98.4 ft) respectively for two times.

Braking distance : As described in the “travel in high gear – stowed” test requirements, once the machine reaches the maximum drive speed, immediately release the control handle (starting timing) until the machine stops. Perform this maneuver for two times.

Note: For Japan models, the machine cannot travel while elevated to operating position.

3.3 SPECIFICATIONS OF MAJOR COMPONENTS

Drive Reducer

Table 3-3 DC Drive Motor and Reducer System (PN.203010003032)

Electric motor	
Rated voltage	24 VDC
Rated power	400 W
Rated current	28 A
Rated speed	4300 rpm
Brake	
Voltage	24 VDC
Power	12.5 W
Torque	6 Nm (4.4 ft-lb)
Reducer	
Maximum torque	350 Nm (258 ft-lb)
Continuous torque	125 Nm (92 ft-lb)
Maximum speed	5000 rpm
Reduction ratio	50: 1

Power Unit

Table 3-4 Power Unit (PN.202010003059)

Maximum pressure	19 MPa (2756 psi)
Electric motor	
Power	2.2 kW
Voltage	24 V
Rated speed	2750 rpm
Pump	
Displacement	2.0 ml/r

Table 3-5 Power Unit (PN.202010003101)

Maximum pressure	19 MPa (2756 psi)
Electric motor	
Power	2.2 kW

Table 3-5 Power Unit (PN.202010003101) (continued)

Voltage	24 V
Rated speed	2750 rpm
Pump	
Displacement	2.0 ml/r

Table 3-6 Power Unit (PN.202010003070)

Maximum pressure	19 MPa (2756 psi)
Electric motor	
Power	2.2 kW
Voltage	24 V
Rated speed	2500–2900 rpm
Pump	
Displacement	2.1 ml/r

Table 3-7 Power Unit (PN.202010003045)

Maximum pressure	19 MPa (2756 psi)
Electric motor	
Power	2.2 kW
Voltage	24 V
Rated speed	2500–2900 rpm
Pump	
Displacement	2.1 ml/r

Battery

Table 3-8 Lithium Battery (PN.203100003071)

Rated voltage	25.6 V
Rated capacity	100 Ah
End-of voltage	21.6 V
Standard charge current	15 A
Continuous discharge current	100 A


Table 3-9 Maintenance-free AGM Battery (PN.203100000060)

Rated voltage	12 V
Rated capacity	110 Ah (10 hr) 95 Ah (5 hr)

Table 3-10 Maintenance-free AGM Battery (PN.203100003091)

Model	6-DF-120
Rated voltage	12 V
Rated capacity (at room temperature of 25°C)	125 Ah (10 hr) 114 Ah (3 hr)
Voltage at end of discharge by 80%	10.5 V
Charging curve code	183 (Longsheng charger) 202 (Tuobang charger) 13 (Yiyuan charger)

3.4 WEIGHT OF MAJOR COMPONENTS

 **WARNING**

- **Never attempt to move heavy components without the assistance of mechanical equipment.**
- **Never place heavy components at an unstable position.**

Table 3-11 Maintenance-free AGM Battery (PN.203100000048)

Model	EV31A-A115AH
Rated voltage	12 V
Charging curve code	b48 (Longsheng charger) 203 (Tuobang charger) 12 (Yiyuan charger)

Table 3-12

Component	Metric (kg)	Imperial (lb)
Chassis assembly	600	1323
Scissor arms assembly	230	507
Platform assembly	170	375
Solid tire	7	15.5
Drive reducer	16	35
Left chassis door	28	62
Right chassis door	20	44
Wheel carrier	12	26.5
Power unit	13	29
Lift cylinder	22	49
Steering cylinder	9	20
Lead-acid battery (cell)	35	77
Lithium battery (cell)	26	57
Note: The weight of certain components will vary with the machine's option configuration.		

3.5 PRESSURE SETTINGS

Table 3-13

Movement	Maximum pressure
Platform lifting, wheel steering	19 MPa (2756 psi)

3.6 OIL REQUIREMENTS

NOTICE

- Please choose suitable oil according to the ambient temperature and local regulations; the use of unsuitable oil will damage the machine components.
- Oils of different grades or viscosities should not be mixed. When refilling oil, the oil being added must be of the same grade and viscosity as that of the oil currently in use in the machine.
- For special environments or special operating requirements please contact Sinoboom.



WARNING

- Before refilling oil, wait until the temperature of the machine drops to room temperature, otherwise it may cause splashes, burns or other personal injury.
- The use of inferior oils is strictly prohibited. Using inferior oil may damage the machine, and faults caused by this are not covered by Sinoboom's warranty.

Hydraulic Oil

Factory-filled hydraulic oil is usually L-HV32 or L-HM46 or as specified by customers. Different regions have different temperature environments, so please select the hydraulic oil suitable for your region according to the recommendations in the table below.

Table 3-14

Ambient temperature range	Sinopec	Mobil	Shell	Castrol
> 40°C (104°F)	AE46	DTE 10 Excel 46	S2M46	Hyspin AWH-M46
-25°C ~ 40°C (-13°F ~ 104°F)	L-HV32	DTE 10 Excel 32	TELLUS-S3VE32	Hyspin HVI-32
<-30°C (-22°F)	Special oil required, to be determined			

3.7 TORQUE SPECIFICATIONS

Special Torque Requirements

Please refer to the table below for special torque requirements:

Table 3-15 Special torque requirements

No.	Description	Torque value
1	Drive motor and reducer mounting bolt	53 Nm (39 ft-lb)
2	Rear wheel locking nut	400 Nm (295 ft-lb)

Table 3-15 Special torque requirements (continued)

No.	Description	Torque value
3	Cable fastening nut M8	9 – 11 Nm (6.6 – 8.1 ft-lb)
4	Cable fastening nut M10	18 – 23 Nm (13.2 – 17 ft-lb)

Fastener Torque Specifications

Torque metric bolts to the values specified in the table below unless special torque requirements are stated in this manual or other instructions.

Table 3-16 Fastener torque specifications – metric

Nominal diameter (mm)	Pitch (mm)	Class 8.8	Class 10.9	Class 12.9
5	0.8	7 Nm (5 ft-lb)	9 Nm (7 ft-lb)	10 Nm (7 ft-lb)
6	1	12 Nm (9 ft-lb)	15 Nm (11 ft-lb)	18 Nm (13 ft-lb)
8	1.25	30 Nm (22 ft-lb)	35 Nm (26 ft-lb)	42 Nm (31 ft-lb)
	1	30 Nm (22 ft-lb)	37 Nm (27 ft-lb)	45 Nm (33 ft-lb)
10	1.5	55 Nm (41 ft-lb)	75 Nm (55 ft-lb)	85 Nm (63 ft-lb)
	1.25	56 Nm (41 ft-lb)	77 Nm (57 ft-lb)	87 Nm (64 ft-lb)
	1	60 Nm (44 ft-lb)	80 Nm (59 ft-lb)	92 Nm (68 ft-lb)
12	1.75	95 Nm (70 ft-lb)	125 Nm (92 ft-lb)	150 Nm (111 ft-lb)
	1.5	100 Nm (74 ft-lb)	130 Nm (96 ft-lb)	155 Nm (114 ft-lb)
	1.25	105 Nm (77 ft-lb)	135 Nm (100 ft-lb)	160 Nm (118 ft-lb)
14	2	150 Nm (110 ft-lb)	200 Nm (148 ft-lb)	230 Nm (170 ft-lb)
	1.5	165 Nm (122 ft-lb)	210 Nm (155 ft-lb)	250 Nm (184 ft-lb)
16	2	230 Nm (170 ft-lb)	300 Nm (221 ft-lb)	360 Nm (266 ft-lb)
	1.5	250 Nm (184 ft-lb)	320 Nm (236 ft-lb)	380 Nm (280 ft-lb)
18	2.5	320 Nm (236 ft-lb)	420 Nm (310 ft-lb)	500 Nm (369 ft-lb)
	1.5	360 Nm (266 ft-lb)	470 Nm (345 ft-lb)	550 Nm (406 ft-lb)
20	2.5	450 Nm (332 ft-lb)	600 Nm (443 ft-lb)	700 Nm (516 ft-lb)
	1.5	500 Nm (369 ft-lb)	650 Nm (479 ft-lb)	770 Nm (568 ft-lb)
22	2.5	600 Nm (443 ft-lb)	800 Nm (590 ft-lb)	980 Nm (723 ft-lb)
	2	650 Nm (479 ft-lb)	850 Nm (627 ft-lb)	1050 Nm (774 ft-lb)
24	3	750 Nm (553 ft-lb)	1050 Nm (774 ft-lb)	1250 Nm (923 ft-lb)
	2	800 Nm (590 ft-lb)	1100 Nm (811 ft-lb)	1300 Nm (959 ft-lb)
27	3	1150 Nm (848 ft-lb)	1500 Nm (1106 ft-lb)	1800 Nm (1327 ft-lb)
30	3.5	1500 Nm (1106 ft-lb)	2000 Nm (1475 ft-lb)	2400 Nm (1770 ft-lb)

Unless special torque requirements are specified in this manual or other instructions, torque Unified Thread Standard bolts (label: UNF) to the values specified in the table below.

Table 3-17 Fastener torque specifications – Unified Thread Standard (UNC)

Nominal diameter (in)	Opposite nut size (s)	Class 5	Class 8
1/4-20	7/16"	10 Nm (7 ft-lb)	14 Nm (10 ft-lb)
5/16-18	1/2"	21 Nm (15 ft-lb)	29 Nm (21 ft-lb)
3/8-16	9/16"	37 Nm (27 ft-lb)	51 Nm (38 ft-lb)
7/16-14	5/8"	60 Nm (44 ft-lb)	82 Nm (60 ft-lb)
1/2-13	3/4"	90 Nm (66 ft-lb)	130 Nm (96 ft-lb)
9/16-12	13/16"	130 Nm (96 ft-lb)	180 Nm (133 ft-lb)
5/8-11	15/16"	178 Nm (131 ft-lb)	250 Nm (184 ft-lb)
3/4-10	1-1/8"	315 Nm (232 ft-lb)	445 Nm (328 ft-lb)
7/8-9	-	509 Nm (375 ft-lb)	715 Nm (527 ft-lb)

Unless special torque requirements are specified in this manual or other instructions, torque Unified Thread Standard bolts (label: UNF) to the values listed in the table below.

Table 3-18 Fastener torque specification-Unified Thread Standard bolts (UNF)

Nominal diameter (in)	Opposite nut size (s)	Class 5	Class 8
1/4-28	7/16"	11.5 Nm (8 ft-lb)	16 Nm (11 ft-lb)
5/16-24	1/2"	23 Nm (17 ft-lb)	32 Nm (24 ft-lb)
3/8-24	9/16"	41 Nm (30 ft-lb)	58 Nm (43 ft-lb)
7/16-20	5/8"	65 Nm (48 ft-lb)	92 Nm (68 ft-lb)
1/2-20	3/4"	100 Nm (74 ft-lb)	145 Nm (107 ft-lb)
9/16-18	13/16"	145 Nm (107 ft-lb)	200 Nm (148 ft-lb)
5/8-18	15/16"	200 Nm (148 ft-lb)	280 Nm (207 ft-lb)
3/4-16	1-1/8"	350 Nm (258 ft-lb)	495 Nm (365 ft-lb)
7/8-14	-	560 Nm (413 ft-lb)	780 Nm (575 ft-lb)

Hydraulic Hose Torque

The hydraulic hoses must be installed with the following torques.

Table 3-19 Hydraulic Hose Torque

Metric thread	L (light-duty)	S (heavy-duty)
M12 × 1.5	19±1 Nm (14±1 ft-lb)	
M14 × 1.5	26±2 Nm (19±2 ft-lb)	
M16 × 1.5	40±3 Nm (30±2 ft-lb)	
M18 × 1.5	50±4 Nm (37±3 ft-lb)	
M20 × 1.5	-	60±4 Nm (44±3 ft-lb)

Table 3-19 Hydraulic Hose Torque (continued)

Metric thread	L (light-duty)	S (heavy-duty)
M22 × 1.5	70±5 Nm (52±4 ft-lb)	-
M24×1.5	-	85±6 Nm (63±4 ft-lb)
M26 × 1.5	90±6 Nm (66±4 ft-lb)	-
M30 × 2	120±8 Nm (89±6 ft-lb)	140±10 Nm (103±7 ft-lb)
M36 × 2	150±12 Nm (111±9 ft-lb)	180±12 Nm (133±9 ft-lb)
M42 × 2	-	260±16 Nm (192±12 ft-lb)
M45 × 2	240±15 Nm (177±11 ft-lb)	-
M52 × 2	250±16 Nm (184±12 ft-lb)	280±18 Nm (207±13 ft-lb)

Hydraulic Fitting Torque

The hydraulic fittings with metric thread must be installed with the following torques.

Table 3-20 Hydraulic Fitting Torque – Metric

Thread size	Installed with aluminum	Installed with steel	
	ED, O-ring + Circlip	ED, O-ring + Circlip	O-ring seal
L (light-duty)			
M10×1	18±1 Nm (13±1 ft-lb)	20±2 Nm (15±2 ft-lb)	18±1 Nm (13±1 ft-lb)
M12×1.5	30±2 Nm (22±2 ft-lb)	35±2 Nm (26±2 ft-lb)	30±2 Nm (22±2 ft-lb)
M14×1.5	42±3 Nm (31±2 ft-lb)	48±4 Nm (35±3 ft-lb)	35±2 Nm (26±2 ft-lb)
M16×1.5	55±4 Nm (41±3 ft-lb)	60±4 Nm (44±3 ft-lb)	40±3 Nm (30±3 ft-lb)
M18×1.5	75±5 Nm (55±4 ft-lb)	75±5 Nm (55±4 ft-lb)	45 ± 3 Nm (33 ± 4 ft-lb)
M22×1.5	90±6 Nm (66±4 ft-lb)	130±8 Nm (96±6 ft-lb)	60±4 Nm (44±3 ft-lb)
M27×2	120±8 Nm (89±6 ft-lb)	185±12 Nm (136±9 ft-lb)	100±7 Nm (74±5 ft-lb)
M30×2	140±8 Nm (103±6 ft-lb)	245±15 Nm (181±11 ft-lb)	135±8 Nm (100±6 ft-lb)
M33×2	180±10 Nm (133±7 ft-lb)	320±20 Nm (236±15 ft-lb)	160±10 Nm (118±7 ft-lb)
M42×2	240±15 Nm (177±11 ft-lb)	450 ± 25 Nm (332 ± 18 ft-lb)	210±13 Nm (155±10 ft-lb)
M48×2	280±20 Nm (207±15 ft-lb)	540±30 Nm (398±22 ft-lb)	260±15 Nm (192±11 ft-lb)
S (heavy-duty)			
M12×1.5	33±2 Nm (24±2 ft-lb)	43±3 Nm (32±2 ft-lb)	35±2 Nm (26±2 ft-lb)
M14×1.5	42±3 Nm (31±2 ft-lb)	50±4 Nm (37±3 ft-lb)	45 ± 3 Nm (33 ± 2 ft-lb)
M16×1.5	55±4 Nm (41±3 ft-lb)	75±5 Nm (55±4 ft-lb)	55±4 Nm (41±3 ft-lb)
M18×1.5	75±5 Nm (55±4 ft-lb)	95±6 Nm (70±4 ft-lb)	70±5 Nm (52±4 ft-lb)
M22×1.5	90±6 Nm (66±4 ft-lb)	140±8 Nm (103±6 ft-lb)	100±10 Nm (74±7 ft-lb)
M27×2	120±8 Nm (89±6 ft-lb)	185±12 Nm (136±9 ft-lb)	160±10 Nm (118±7 ft-lb)
M30×2	140±8 Nm (103±6 ft-lb)	245±15 Nm (181±11 ft-lb)	210±13 Nm (155±10 ft-lb)

Table 3-20 Hydraulic Fitting Torque – Metric (continued)

Thread size	Installed with aluminum	Installed with steel	
	ED, O-ring + Circlip	ED, O-ring + Circlip	O-ring seal
M33×2	180±10 Nm (133±7 ft-lb)	320±20 Nm (236±15 ft-lb)	260±15 Nm (192±11 ft-lb)
M42×2	240±15 Nm (177±11 ft-lb)	450 ± 25 Nm (332 ± 18 ft-lb)	330±20 Nm (243±15 ft-lb)
M48×2	280±20 Nm (207±15 ft-lb)	540±30 Nm (398±22 ft-lb)	420±25 Nm (310±18 ft-lb)

The hydraulic pipe fittings with British Standard Pipe (BSP) thread must be installed with the following torques.

Table 3-21 Hydraulic Fitting Torque - British Standard Pipe (BSP)

Thread size	Installed with aluminum	Installed with steel	
	ED, O-ring + Circlip	ED, O-ring + Circlip	O-ring seal
L (light-duty)			
G1/8A	20±1 Nm (15±1 ft-lb)	20±1 Nm (15±1 ft-lb)	-
G1/4A	35±2 Nm (26±2 ft-lb)	40±2 Nm (30±2 ft-lb)	-
G3/8A	50±3 Nm (37±2 ft-lb)	75±5 Nm (55±2 ft-lb)	-
G1/2A	75±5 Nm (55±2 ft-lb)	95±6 Nm (70±4 ft-lb)	-
G3/4A	120±8 Nm (89±6 ft-lb)	185±12 Nm (136±9 ft-lb)	-
G1A	180±10 Nm (133±7 ft-lb)	320±20 Nm (236±15 ft-lb)	-
G1-1/4A	240±15 Nm (177±11 ft-lb)	450 ± 25 Nm (332 ± 18 ft-lb)	-
G1-1/2A	280±20 Nm (207±15 ft-lb)	540±30 Nm (398±22 ft-lb)	-
S (heavy-duty)			
G1/4A	40±3 Nm (30±2 ft-lb)	43±3 Nm (32±2 ft-lb)	-
G3/8A	55±3 Nm (41±2 ft-lb)	85±5 Nm (63±4 ft-lb)	-
G1/2A	80±5 Nm (59±4 ft-lb)	120±8 Nm (89±6 ft-lb)	-
G3/4A	120±8 Nm (89±6 ft-lb)	185±12 Nm (136±9 ft-lb)	-
G1A	180±10 Nm (133±7 ft-lb)	320±20 Nm (236±15 ft-lb)	-
G1-1/4A	240±15 Nm (177±11 ft-lb)	450 ± 25 Nm (332 ± 18 ft-lb)	-
G1-1/2A	280±20 Nm (207±15 ft-lb)	540±30 Nm (398±22 ft-lb)	-

The hydraulic pipe fittings with Unified Thread Standard (UNC/UNF) thread must be installed with the following torques.

Table 3-22 Hydraulic Fitting Torque - Unified Thread Standard (UNC/UNF)

Thread size	Installed with aluminum	Installed with steel
	O-ring seal	O-ring seal
L (light-duty)		
7/16-20	21±2 Nm (15±2 ft-lb)	21±2 Nm (15±2 ft-lb)
9/16-18	34±2 Nm (25±2 ft-lb)	35±2 Nm (26±2 ft-lb)
11/16-12	40±3 Nm (30±2 ft-lb)	50±4 Nm (37±3 ft-lb)

Table 3-22 Hydraulic Fitting Torque - Unified Thread Standard (UNC/UNF) (continued)

Thread size	Installed with aluminum	Installed with steel
	O-ring seal	O-ring seal
3/4-16	50±3 Nm (37±2 ft-lb)	65±4 Nm (48±3 ft-lb)
7/8-14	75±5 Nm (55±4 ft-lb)	110±8 Nm (81±6 ft-lb)
1-1/16-12	110±8 Nm (81±6 ft-lb)	140±10 Nm (103±7 ft-lb)
1-5/16-12	160±10 Nm (118±7 ft-lb)	210±15 Nm (155±11 ft-lb)
S (heavy-duty)		
7/16-20	21±2 Nm (15±2 ft-lb)	23±2 Nm (17±2 ft-lb)
9/16-18	34±2 Nm (25±2 ft-lb)	40±3 Nm (30±2 ft-lb)
11/16-12	40±3 Nm (30±2 ft-lb)	65±4 Nm (48±3 ft-lb)
3/4-16	50±3 Nm (37±2 ft-lb)	80±6 Nm (59±4 ft-lb)
7/8-14	75±5 Nm (55±4 ft-lb)	125±10 Nm (92±7 ft-lb)
1-1/16-12	110±8 Nm (81±6 ft-lb)	185±15 Nm (136±11 ft-lb)
1-5/16-12	160±10 Nm (118±7 ft-lb)	280±20 Nm (207±15 ft-lb)

This Page Intentionally Left Blank

4 MAINTENANCE INSTRUCTIONS

4.1 INSPECTION AND PREVENTATIVE MAINTENANCE SCHEDULE

This section provides safety and other vital information for machine operators. To extend the service life of the machine and ensure safe operation, all necessary inspections and maintenance work must be completed before the machine is put into service.

It is crucial to develop and adhere to a comprehensive inspection and preventive maintenance program. This manual outlines the regular inspections and maintenance procedures recommended by Hunan Sinoboom Intelligent Co., Ltd. Consult your national, regional or local regulations for aerial work platforms. The frequency of the inspection and maintenance must be increased as required by environmental conditions, requirements and frequency of usage.

Pre-delivery Inspection (PDI)

The pre-delivery inspection shall be performed by qualified Sinoboom technicians.

A pre-delivery inspection shall be performed before each sale, lease or rental delivery.

Refer to the **Inspection and Preventive Maintenance Schedule** for items requiring a PDI. Refer to the corresponding section of this manual to perform inspection and maintenance procedures.

Pre-operation Inspection

A pre-operation inspection must be performed before each start or restart of work, change of operator, and after each maintenance operation. Refer to the pre-operation inspection section of the Operation Manual for detailed information. The Operation Manual must be entirely read and understood before performing the pre-operation inspection.

Regular Inspections

Regular inspections shall be performed by qualified Sinoboom technicians.

Regular inspections must be performed after the machine has been in service for 3 months or 250 hours, whichever comes first, or if it has been out of service for more than 3 months. The frequency of the inspection and maintenance must be increased as required by environmental conditions, requirements and frequency of usage.

The items included in the regular inspections are identical to the pre-delivery inspection.

Annual Inspection

An annual machine inspection must be performed once a year and no later than 13 months from the date of the previous annual inspection. Hunan Sinoboom Intelligent Equipment Co., Ltd. recommends this task be performed by a factory-trained service technician, a person recognized by Sinoboom as one who, by qualification, certificate and training, has successfully demonstrated the ability and proficiency to service, repair and maintain the Sinoboom model in question.

Refer to the **Inspection and Preventive Maintenance Schedule** for items requiring annual inspection, and refer to the corresponding section of this manual to perform inspection and maintenance procedures.

Preventive Maintenance

Preventive maintenance procedures shall be performed by qualified Sinoboom technicians. The frequency of the inspection and maintenance must be increased as required by environmental conditions, requirements and frequency of usage.

Refer to the **Inspection and Preventive Maintenance Schedule** for items requiring a PDI. Refer to the corresponding section of this manual to perform inspection and maintenance procedures.

Responsible Persons and Qualifications for Performing Inspection and Maintenance

Table 4-1

Inspection Type	Inspection Frequency	Primary Responsible Persons	Service Qualifications
Pre-operation Inspection	Before starting/restarting work, change of user, after each maintenance activity.	User or operator	Properly trained user or operator
Pre-delivery Inspection (PDI)	Before each sale, lease or rental delivery	Owner, dealer or user	Qualified Sinoboom technician
Regular Inspections	In service for 3 months or 250 hours (whichever comes first) or out of service for more than 3 months	Owner, dealer or user	Qualified Sinoboom technician
Annual Inspection	Once a year and no later than 13 months from the date of the previous annual inspection	Owner, dealer or user	Factory-trained service technician
Preventive Maintenance	At intervals specified in the Inspection and Preventive Maintenance Schedule	Owner, dealer or user	Qualified Sinoboom technician

Inspection and Preventive Maintenance Schedule

Perform inspection and preventive maintenance for the items in the table below at the specified intervals. Maintenance and inspection intervals are calculated based on the months of service or the “accumulated operating hours” (cumulative working time) displayed on the ground controls (whichever comes first).

Inspection intervals are based on the use of the machine under normal operating conditions. The intervals should be shortened accordingly when operating in harsh environmental conditions.

Table 4-2 Inspection and Preventive Maintenance Schedule

Item	Interval		
	Before each delivery ¹ or quarterly ²	Semiannually ³	Annually ⁴
Platform assembly			
Platform	1	1	1
Guardrails and floor	2	2	2
Access gate	1, 2, 3	1, 2, 3	1, 2, 3
Pedal for platform extension	1, 2, 3	1, 2, 3	1, 2, 3
Platform wear pads (at the connection with scissor arm) and fasteners	1, 2	1, 2	1, 2
Safety belt anchorage point	1, 2, 7	1, 2, 7	1, 2, 7
Scissor arms assembly			

Table 4-2 Inspection and Preventive Maintenance Schedule (continued)

Item	Interval		
	Before each delivery ¹ or quarterly ²	Semiannually ³	Annually ⁴
Scissor arms	1, 2	1, 2	1, 2
Safety strut	1, 2, 3	1, 2, 3	1, 2, 3
Bearings	1, 2, 5, 12	1, 2, 5, 12	1, 2, 5, 8, 12
Pivot pins, retaining rings and fasteners	1, 2	1, 2	1, 2
Chassis assembly			
Chassis	2	2	2
Chassis wear pads (at the connection with scissor arm)	1, 2, 5	1, 2, 5	1, 2, 5, 8
Tires	1, 2	1, 2	1, 2
Wheel nuts	1 ⁵⁰	1 ⁵⁰	1 ⁵⁰
Traveling and steering components	1, 2, 5	1, 2, 5	1, 2, 5
Bearings	1, 2, 5, 12	1, 2, 5, 12	1, 2, 5, 12
Chassis door at both sides	1, 2, 3	1, 2, 3	1, 2, 3
Ladder	1, 2, 5	1, 2, 5	1, 2, 5
Drive motor	1, 5, 6	1, 5, 6	1, 5, 6
Brake and brake release device	1, 5, 6	1, 5, 6	1, 5, 6
Lift motor	1, 2, 3, 6	1, 2, 3, 6, 13	1, 2, 3, 6, 13
Gear pump	1, 2, 3, 6	1, 2, 3, 6	1, 2, 3, 6
Hydraulic system			
Hydraulic pump	1, 2, 3, 6	1, 2, 3, 6	1, 2, 3, 6
Hydraulic cylinder	1, 2, 3, 5, 6, 12	1, 2, 3, 5, 6, 12	1, 2, 3, 5, 6, 12
Hydraulic valves	1, 2, 3, 5, 6	1, 2, 3, 5, 6	1, 2, 3, 5, 6
Hydraulic hoses, pipes and fitting	1, 2, 6	1, 2, 6	1, 2, 6
Hydraulic tank	1, 2, 3, 5, 6	1, 2, 3, 5, 6	1, 2, 3, 5, 6
Hydraulic tank air filter	1, 5, 6	1, 5, 6, 11	1, 5, 6, 11
Hydraulic oil filter	1, 5, 6	1, 5, 6	1, 5, 6, 11
Hydraulic oil	5, 6	5, 6	5, 6, 11
Electrical system			
Electrical harness, connectors	1, 2	1, 2	1, 2
Battery	1, 2, 6, 9, 12	1, 2, 6, 9, 12	1, 2, 6, 9, 12
Electrolyte	6	6	6
Charging function	3	3	3

Table 4-2 Inspection and Preventive Maintenance Schedule (continued)

Item	Interval		
	Before each delivery ¹ or quarterly ²	Semiannually ³	Annually ⁴
Instruments, gauges, switches, lamps, horn	1, 3	1, 3	1, 3
Functions and controls			
Platform controller	1, 3, 4, 7, 10	1, 3, 4, 7, 10	1, 3, 4, 7, 10
Ground controller	1, 3, 4, 7, 10	1, 3, 4, 7, 10	1, 3, 4, 7, 10
Function control lock, secondary guarding device and brake	1, 3, 10	1, 3, 10	1, 3, 10
Emergency stop button (ground and platform)	1, 3, 10	1, 3, 10	1, 3, 10
Limit switches and power switch	1, 3, 10	1, 3, 10	1, 3, 10
Overload limit function	1, 3, 10	1, 3, 10	1, 3, 10
Tilt alarm	1, 3, 10	1, 3, 10	1, 3, 10
Pothole protection device	1, 3, 10	1, 3, 10	1, 3, 10
Emergency lowering device	1, 3, 10	1, 3, 10	1, 3, 10
Drive function	1, 3, 10	1, 3, 10	1, 3, 10
Brake function	1, 3, 10	1, 3, 10	1, 3, 10
Other			
Operation Manual in the manuals compartment	10	10	10
All decals/labels complete, clear and secure	10	10	10
Annual inspection date of the machine	/	/	10
No unapproved changes or additions	10	10	10
All safety publications taken into account	10	10	10
General structural components and weldments	2	2	2
All fasteners, pins, protective guards and covers	1, 2	1, 2	1, 2
Greasing and lubricating according to specifications	10	10	10
Functional test of all systems	10	10	10
Paint and appearance	5	5	5
Inspection date stamped on the chassis	/	/	10
Notify Sinoboom of machine ownership (change)	/	/	10

Table 4-2 Inspection and Preventive Maintenance Schedule (continued)

Item	Interval		
	Before each delivery ¹ or quarterly ²	Semiannually ³	Annually ⁴
<p>Note:</p> <p>¹ Before each sale, lease or shipment delivery;</p> <p>² In service for 3 months or 250 hours; or out of service for more than 3 months;</p> <p>³ In service for 6 months or 500 hours;</p> <p>⁴ Once a year and no later than 13 months from the date of the previous annual machine inspection;</p> <p>⁵⁰ The first inspection shall be performed once the machine reaches 50 hours in service for the first time. This occurs only once in the service life of the machine.</p> <p>²⁵⁰ The first inspection shall be performed once the machine reaches 250 hours in service for the first time. This occurs only once in the service life of the machine.</p> <p>NO.1 Before the machine is put into service for the first time</p>			
<p>Inspection activity (numerical codes):</p> <ol style="list-style-type: none"> 1. Check for correct installation (accurate position, firmly installed, tightened to the specified torque) 2. Visual inspection for damage (cracks, cracked welds, deformation, wear, corrosion, excessive wear, gouges, abrasions and exposed threads) 3. Check for normal function 4. Check for normal return to neutral or "off" position (self-resetting switches return to neutral or "off" position after released) 5. Clean and free of foreign objects 6. Check for correct level, sealing and leaks 7. Labels complete, clear and secure 8. Check for appropriate dimensions/tolerances 9. Fully charged 10. Verify/perform 11. Replace the oil or filter element 12. Correctly lubricated 13. Inspect the carbon brush 			

4.2 GENERAL MAINTENANCE INSTRUCTIONS

Safety and Operating Standards

The following precautions should be taken before carrying out adjustment and repair work on the machine:

1. Disconnect the power source to prevent inadvertent start up of the machine and tag the machine accordingly.

2. All controls should be turned off to avoid accidental actuation of the control system.
3. If possible, lower the work platform to the lowest position. If this is not possible, secure the work platform to prevent it from falling.
4. Before loosening or removing hydraulic components, the oil pressure in the hydraulic lines should be released.

Some maintenance work may require the machine to be in a state other than the ones described in 1-4 above. Such work should be carried out in accordance with the specific safety measures listed in the Operation Manual and this manual.

Safety of personnel always has the highest priority, also when performing maintenance work on the machine. Always take the weight of components into consideration, and never attempt to move heavy parts without the assistance of mechanical equipment. Never place heavy objects in an unstable position. Before lifting any machine components, ensure the parts are sufficiently supported.

Cleaning

1. To extend the service life of the machine it is crucial to prevent dirt or impurities from entering critical components of the machine. A number of protective measures have been taken to prevent such ingress. Protective plates, covers, seals, and filters are installed to keep intake air, fuel and oil clean. Such protective devices must be serviced/maintained at prescribed intervals to ensure their proper function.
2. When air, fuel, or oil lines are disconnected, their adjacent areas, openings and fittings should be cleaned. Openings should be covered immediately to prevent foreign objects from entering.
3. During repair or maintenance, all components should be cleaned and inspected, make sure all pipes/tubes and openings are unobstructed. Cover all parts to keep them clean. All parts must be clean before installation. New parts should be stored in containers before use.

Components Disassembly and Installation

1. A safe and appropriate plan for the installation of machine components should be developed based on this manual, taking the site conditions into account.
2. Personnel carrying out disassembly and installation work must be appropriately qualified and must be able to use safety equipment correctly.
3. Before carrying out installation work, qualified personnel should inspect the ground, concealed foundations and anchors, or review reliable documentation verifying that the manufacturer's requirements are met.
4. Wind speed at the installation site must not exceed 8.3 m/s (18.6 mph).
5. Before installation, check the site conditions such as power supply and ground conditions to make sure the installation requirements are met.
6. All components should be inspected prior to installation to verify they are in good condition.
7. High-strength bolts should be tightened in strict accordance with the requirements of this manual.
8. Requirements for the acceptance of onsite machine installation work:

- 1) Relevant inspections and functional tests should be carried out to confirm that the components have been installed correctly, that specific functional requirements are met and that all safety devices are operating properly.
 - 2) Static and dynamic load tests should follow and comply with the relevant standards.
 - 3) Before putting the machine into service, a qualified person shall issue a handover certificate confirming the integrity of the machine. All test/inspection results should be recorded and an inspection report should be prepared (including the inspector's name, title, company, and inspection date).
9. Disassembly work should meet the same safety requirements as installation work.
 10. If lifting tools are required to dis-assemble the machine, use the correct lifting points, lifting equipment and additional tools. Only use tested and certified tools and equipment.
 11. If the lifting gear strands have to be attached at an angle of less than 90° when lifting a component exercise special caution since the eye bolt or similar bracket cannot provide adequate lateral support.
 12. If components are difficult to be removed check that all nuts, bolts, cables, brackets, wiring, etc. have been removed, and that adjacent components are not obstructing the removal.

Components Disassembly and Reassembly

When disassembling or reassembling components, follow the steps one by one. If assembly/disassembly of a certain component has not been completed, do not proceed with another component. Always check the disassembly/assembly operation to make sure nothing is missing. No adjustments (unless recommended) may be made without prior approval.

Storage

Please follow the recommendations below to ensure best performance of the cylinders and to avoid corrosion during long-term storage (indoor/outdoor):

- The machine should be stored in stowed position with the wheels aligned.
- Fully raise and lower the platform, and steer left and right to the full steering angle twice a week in order to keep the respective cylinder components lubricated.

Disposal of Structural Components

- Major structural components that no longer meet the requirements for safe use due to corrosion, wear or other reasons should be repaired, reinforced, or replaced and discarded.
- Load-bearing structural components that are permanently deformed and cannot be repaired must be replaced and discarded.
- Load-bearing structural components that have lost overall stability and cannot be repaired must be replaced and discarded.
- Cracks in structural components or welds should be analyzed to understand the cause. The components/welds should be reinforced as appropriate considering the load and the characteristics of the cracks. Continued use is only allowed if the structural component/weld meet the original design requirements; otherwise they should be discarded.

Pressure-fit Parts

When assembling pressure-fit parts, use anti-seize or molybdenum disulfide-based compounds to lubricate the mating surface.

Bearings

1. Cover bearings that have been removed from the machine to keep the bearing clean from dust and abrasives. Use non-flammable cleaning solvent to clean bearings and allow them to dry in a shaded area. Compressed air may be used but the bearings should not be rotated.
2. If the races and balls (or rollers) display pits, notches or burn marks, the bearing should be replaced and discarded.
3. If the bearing is still serviceable, apply a coat of oil and wrap it in clean paper (or wax paper). Do not unwrap reusable bearings or new bearings until they are ready for installation.
4. Lubricate new or serviceable bearings before installation. When pressing the bearing into the retainer or bore, pressure should be applied only to the outer race. If the bearing is to be installed on a shaft, pressure should be applied only to the inner race.

Gaskets

Check if the opening in the gasket is aligned with the opening in the component that is to be sealed.

Bolt Use and Torque Requirements

NOTICE

Self-locking fasteners such as nylon inserts and thread locking nuts must not be reinstalled after removal.

1. Always use a new self-locking fastener when installing locking fasteners. Use bolts of appropriate lengths. If a bolt is too long it may be pressed against the adjacent part before being properly tightened. If the bolt is too short it is likely to not have enough thread area to properly secure the parts. Replacement bolts must be of the same or equivalent size as the original bolt.
2. In addition to the specific torque requirements provided in this manual, standard torque values should be used on heat-treated bolts, studs, and steel nuts in accordance with recommended factory practice (see [Page 17, Fastener Torque Specifications](#)).

Hydraulic Pipeline and Electrical Wiring

When unplugging or removing hydraulic hoses and electrical wires from the machine, the hydraulic hoses and electrical wires and their sockets should be clearly marked so that their reinstallation will be correct.

Hydraulic Hose and Fitting Tightening Procedures

The following requirements apply when installing hydraulic hoses and fittings:

1. Before installation, check the seals on hoses and fittings, and replace the seal or even the hose assembly and the fitting if the seal is found to be damaged or oil spills out of the seal. Clean hoses and fittings before installation.
2. If a seal is to be replaced, lubricate the replacement seal before installation.
3. To install a hose nut and fitting, align the fitting, hose and hose nut, and tighten the nut with the torque specified in **Hydraulic Hose Torque** and **Hydraulic Fitting Torque**. If the tightening torque of a fitting or hose exceeds the specified value its seal cannot be reused.
4. After installation, test all machine functions and check to ensure the hose, fitting and related components are free from leaks.

Application of Insulating Silicone Grease to Electrical Connections

Insulating silicone grease should be applied to all electrical connections for the purpose of:

- Avoiding oxidization of the connecting points between the male pin and female pin.
- Avoiding electrical failure due to low conductivity between the pins in humid environments.

The following instructions should be observed when applying insulating silicone grease to the electrical connections. This procedure applies to all plug connections installed outside the distribution cabinet. The silicone grease is not suitable for the connectors with a sealed outer surface.

1. Prior to the machine assembling, apply silicone grease around the male and female pins of the connectors to prevent oxidization. A grease syringe may be used for this procedure.

NOTICE

Oxidization that is allowed to progress over a certain period will increase the resistance of the connectors and eventually lead to electrical failure.

2. Silicone grease should be applied to each electrical cord that is exposed outside the connectors to prevent short circuit. Silicon grease should also be applied to the connecting points of male and female connectors. Sealing measures should also be applied to other connectors that may be subject to water ingress, such as around strain relief clamps.

NOTICE

Due to the higher conductivity of cleaning solvents compared to water, situations of water ingress are especially likely to occur when cleaning the machine with a pressure washing method.

3. The connectors between battery and charger should be sealed with silicone grease at each contact point.

NOTICE

Solidifying sealants can also be used to prevent short circuits and help maintain cleanliness, but they will make it more difficult to remove the pins later on.

Lubrication

The relevant components should be lubricated at defined intervals using the lubricant of the quantity, type and grade as recommended in this manual. If the recommended lubricant is not available, contact your local supplier who can help you obtaining the recommended lubricant or a satisfactory alternative.

Hydraulic System

1. Contaminants are the primary hazard for the hydraulic system. Contaminants can enter the hydraulic system in various ways, such as improper use of hydraulic oil, moisture, grease, metal chips, sealing elements and sand entering the system during maintenance, or cavitation of the hydraulic pump due to insufficient system preheating or leakage in the pump supply (suction) lines.
2. Oil that appears clouded indicates a high moisture or air content, which contributes to organic growth, leading to oxidation or corrosion. In such case, drain the oil from the hydraulic system, and fill with clean hydraulic oil after rinsing the hydraulic system.
3. Check the filter frequently for the presence of metal particles. Because hydraulic components are designed and manufactured to very tight tolerances, even a small amount of contaminants entering the system can cause wear or damage to hydraulic components and lead to malfunctions. Hydraulic system filters should be inspected, cleaned or replaced as needed at required intervals.
4. Keep the hydraulic system clean. After disconnecting the hydraulic lines, seal the tube ports immediately to prevent contaminants from entering the hydraulic system. If signs of metal or rubber particles are found in the hydraulic system, the hydraulic oil should be drained immediately and the entire system flushed.

NOTICE

Metal particles may appear in the hydraulic oil or filter of a new machine due to wear of new hydraulic components.

5. Disassemble or reassemble parts on clean workbenches. Clean all metal parts using a non-flammable cleaning solvent. Lubricate parts as needed to facilitate assembly.
6. Hydraulic oils of different brands or types should not be mixed. Different oils may contain different essential additives or may have different viscosity. It is recommended to use high-quality mineral oil with a viscosity suitable for the temperature of the environment the machine is operating in.
7. Unless otherwise expressly stated in this manual, the filter element must be replaced at least once a year or every 1000 working hours; the replacement interval should be shorter in harsh working conditions. If hydraulic oil needs to be changed, use hydraulic oil meeting or exceeding the type and specification requirements in this manual. If hydraulic oil of the same type as that supplied with the machine is not available, consult your local supplier to help you select the appropriate hydraulic oil. Do not mix petroleum-based oils with synthetic oils.

8. Take all precautions to keep the hydraulic oil clean. If hydraulic oil must be poured from the original container into another container, ensure that the second container is kept clean and does not contain any contaminants. Make sure to clean the filter screen, and replace the filter element when changing the hydraulic oil.
9. After the machine is shut down, take proper preventive maintenance measures, thoroughly check all hydraulic components, piping, fittings, etc., and perform a function test for each system before putting the machine into service again.

Battery

Clean the battery with a non-metallic brush and sodium bicarbonate aqueous solution, then rinse it with clean water. After cleaning, allow the battery to dry completely, and apply anti-corrosion compound to the battery terminals.

Pins and Composite Bearing

1. The connecting pins should be removed and inspected in case any of the following defects is found:
 - Excessively tilted joint
 - Noise originating from the joint during operation.
2. The composite bearing should be replaced in any of the following conditions:
 - Frayed or separated fiber on the sleeve surface
 - Cracked or damaged sleeve housing
 - Bearing moved or rotated into the housing
 - Debris embedded in the sleeve surface.
3. Replace the pivot pin if any of the following is detected (properly clean the pivot pin before inspection):
 - Wear in the bearing area
 - Flaking, peeling, scratches or abrasions on the pivot pin surface
 - Corroded pivot pin in the bearing area
4. Reassemble the connecting pin and composite bearing
 - Blow off the dirt and debris on the housing. Remove any foreign objects on the bearing and housing.
 - Clean the bearing and pivot pin with a cleaning agent to remove all grease and oil. The composite bearing uses dry coupling which does not require lubrication.

- During installation and operation, inspect the pivot pin to ensure that there are no burrs, nicks or abrasions that could damage the bearing.

4.3 MAJOR MODIFICATION AND REPAIR

A major modification/repair is a modification/repair of the entire machine or its components that affects the stability, strength or performance of the machine.

Each major modification/repair to the machine by the machine owner/company should be recorded using the **Major Modification/Repair Record** in the attachment to this manual. This record should be retained until the machine is taken out of service or as required by the machine owner/company.

Major modifications/repairs to the machine must be performed by a qualified service technician. The machine must be inspected and verified after major modifications/repairs, the inspection items include but are not limited to all items in the **Inspection and Preventive Maintenance Schedule**. Once inspection and verification are complete the machine can be put back into service.

This Page Intentionally Left Blank

5 PLATFORM COMPONENTS

The figure below shows platform components. Your machine may have different platform components due to different configuration.

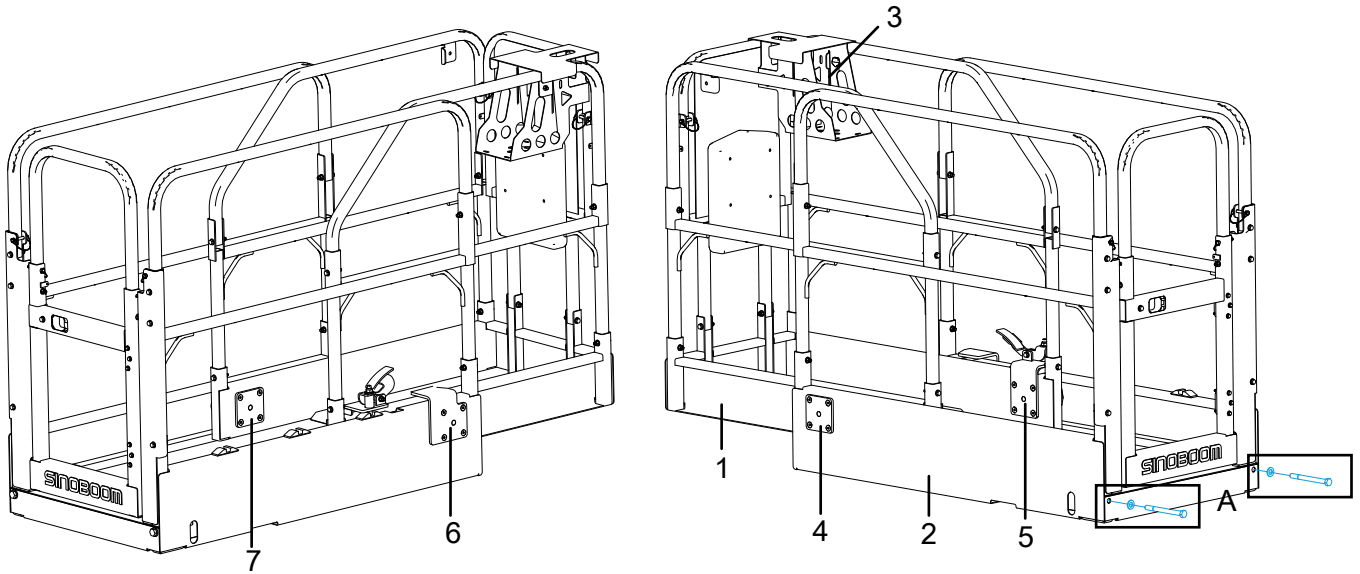


Fig. 1 Diagram of Platform Components

Table 5-1

A: Platform wear pad fixed end installation (including bolts, gaskets and nuts)		
1: Platform extension	2: Main platform	3: Platform controller
4, 5, 6, 7: Pulley support		

5.1 PLATFORM CONTROLLER

Disassembly



WARNING

Before performing such disassembly tasks, disconnect the battery and disconnect the charger from the AC outlet. Contact with live conductors may result in serious injury or death.

1. Make sure the machine is in stowed position.
2. Turn off the machine and press the emergency stop button at the platform controller and ground controller.
3. Mark and disconnect the harness connections in the platform controller.

4. Remove the fastening bolts on the bottom of the platform controller.

5. Carefully remove the platform controller.

Installation

For installation, follow the disassembly procedure in reverse order.

5.2 PLATFORM ASSEMBLY

The platform assembly is composed of the main platform and platform extension. The platform assembly shall be disassembled and installed as follows:

Disassembly

1. Make sure the machine is in stowed position.

2. Remove the platform controller from the platform.
3. Mark and disconnect the harness connections on the platform assembly.
4. Use suitable lifting equipment to support the work platform.
5. Remove the mounting fasteners from the platform wear pad fixed end.
6. With the assistance of the lifting equipment, slowly lift the platform slightly and push the platform so that the wear pad at the mobile end gets to the chute notch at the bottom of the platform.
7. Slowly remove the platform assembly with the aid of the lifting equipment.

Installation

For installation, follow the disassembly procedure in reverse order.

5.3 PLATFORM EXTENSION

Disassembly

1. Extend the platform appropriately, and ensure that the platform extension is effectively supported.
2. Use suitable lifting equipment to support the work platform.
3. Remove the mounting screws on the 4 pulley supports of the platform assembly.
4. Remove the pulley supports.
5. With the assistance of lifting equipment, slowly remove the platform extension from the platform assembly.

Installation

For installation, follow the disassembly procedure in reverse order.

6 SCISSOR ARMS COMPONENTS

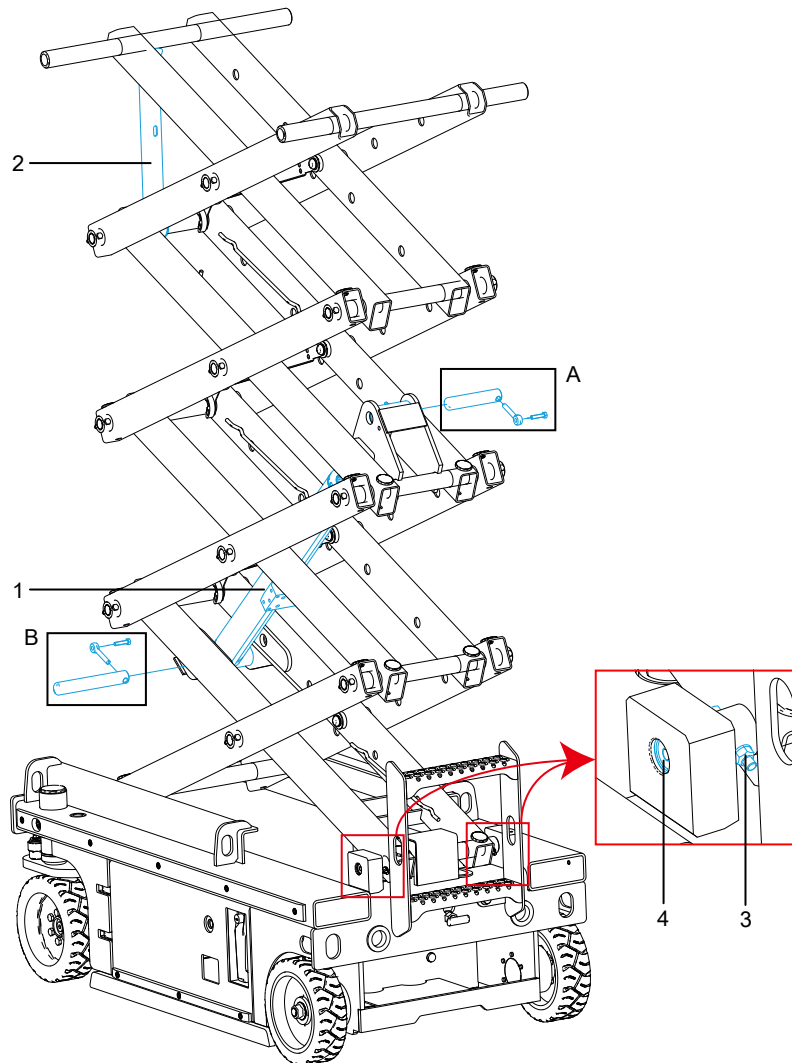


Fig. 1 Diagram of Scissor Arms Components

Table 6-1

A. Cylinder upper end installation (including pivot pin, pin and bolt)		
B. Cylinder lower end installation (including pivot pin, pin and bolt)		
1. Lift cylinder	2. Safety strut	3. Scissor arm assembly fasteners
4. Pivot pin		

6.1 DISASSEMBLY AND INSTALLATION

Disassembly

1. Make sure the machine is in stowed position.
2. Remove the platform assembly.
3. Mark and disconnect the harness connections on the scissor arm assembly.

4. Mark and disconnect the hydraulic pipelines on the scissor arm assembly and collect the hydraulic oil in the pipelines with a suitable vessel. Then seal the pipelines and ports.
5. Use suitable lifting equipment to support the scissor arm assembly.
6. Remove the fasteners securing the scissor arm assembly on both sides of the chassis.
7. Use tools to pull out the pivot pin securing the scissor arm assembly with the chassis.
8. With the assistance of the lifting equipment, horizontally remove the scissor arm assembly from chassis chute slowly and carefully place it at a suitable position.

Installation

For installation, follow the disassembly procedure in reverse order.

2. Erect the safety strut and ensure that the safety strut provides effective support.
3. Use suitable lifting equipment to support the scissor arm assembly to prevent it from falling during the disassembly process.
4. Mark and disconnect the hydraulic pipelines on the lift cylinder and collect the hydraulic oil in the pipelines with a suitable vessel. Then seal the pipelines and ports.
5. Support the two ends of the lift cylinder with suitable lifting equipment.
6. Remove the bolt and stop pin at the pivot pin connecting the lift cylinder upper end with the scissor arm, and knock out the pivot pin with a brass rod and mallet.
7. Remove the bolt and stop pin at the pivot pin connecting the lift cylinder lower end with the scissor arm, and knock out the pivot pin with a brass rod and mallet.
8. Slowly remove the lift cylinder with the aid of the lifting equipment.
9. Slowly lower the scissor arm to stowed position with the aid of the lifting equipment.

6.2 SAFETY STRUT

 **WARNING**

If you need to work under the raised scissor arms, make sure that the safety strut sets up and provides effective support.

1. Start the machine on the ground to raise the platform appropriately so that the safety strut can be fully erected.
2. Erect the safety strut and lower the platform appropriately to ensure that the safety strut provides effective support.
3. Lower the platform until the upper scissor sleeve contacts the safety strut.

 **WARNING**

When disassembling the cylinder, use caution to prevent it from falling and getting damaged, and also to avoid impacts that could lead to high-pressure oil leaks.

Installation

For installation, follow the disassembly procedure in reverse order.

6.3 LIFT CYLINDER

 **WARNING**

- **Before loosening or disassembling hydraulic parts, the hydraulic pressure of all hydraulic lines should be released and the hydraulic oil should completely cool down.**
- **Disassemble the hydraulic components slowly to prevent hydraulic oil from splashing and injuring people.**

1. Raise the scissor arms appropriately until the lift cylinder is accessible and can be easily removed.

7 CHASSIS COMPONENT

7.1 TRAVEL DRIVE AND STEERING DEVICE

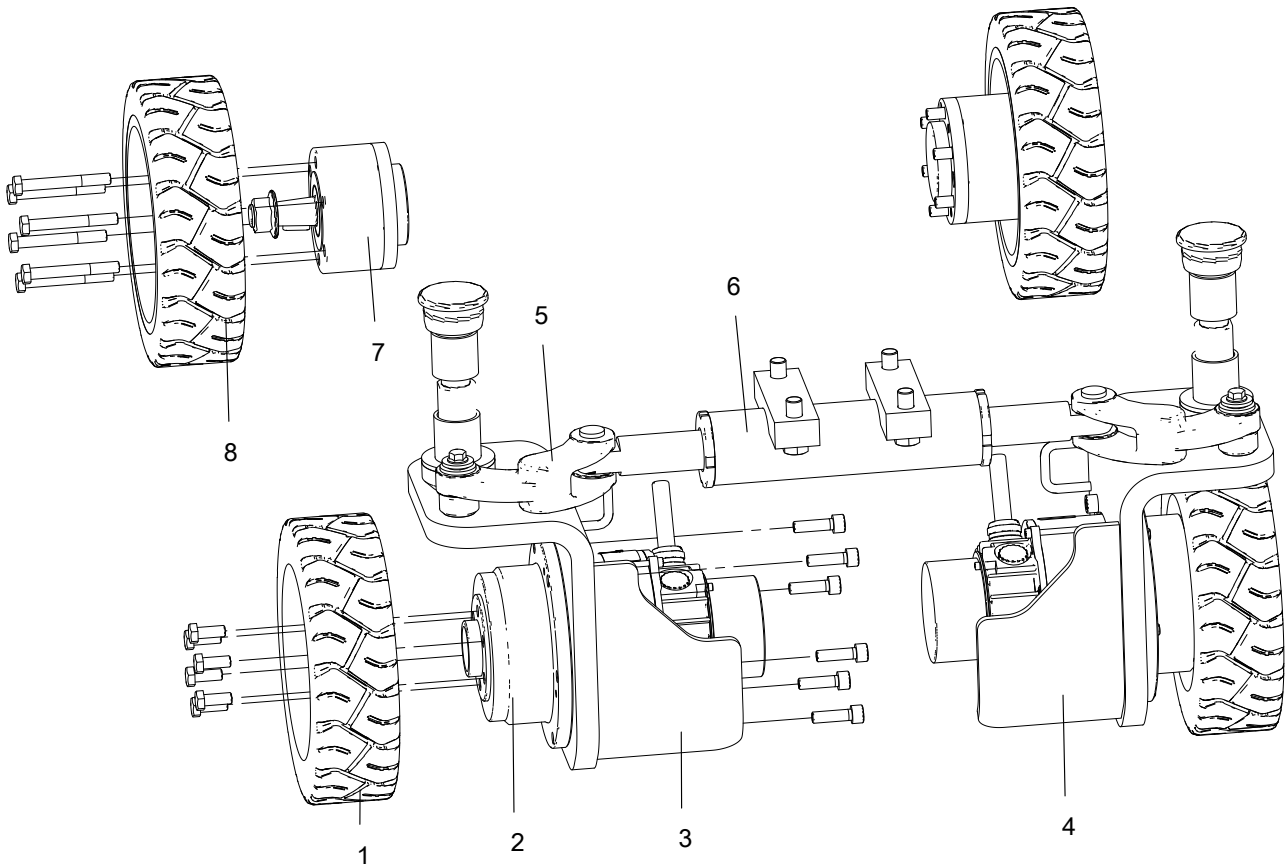


Fig. 1 Diagram of Travel Drive and Steering Device

Table 7-1

1. Front tire	2. Drive motor & reducer	3. Right wheel carrier
4. Left wheel carrier	5. Steering connecting rod	6. Steering cylinder
7. Bearing housing	8. Rear tire	

Drive Motor and Reducer

Disassembly

1. Make sure the machine is in stowed position.
2. Press the main power switch/pull out the main power handle and disconnect all power sources (such as battery charger) from the machine.
3. Place a jack of sufficient capacity under the chassis side to be worked on, and support the chassis.
4. Remove the tire and wheel assembly.
5. Mark and disconnect the harness connections on the drive motor and reducer.
6. Use suitable lifting equipment to support the drive motor and reducer.

- Remove the fasteners of the drive motor and reducer installed on the wheel carrier, and slowly move the drive motor and reducer out with the assistance of lifting equipment.

Installation

- Place a jack of sufficient capacity under the chassis side to be worked on, and support the chassis.
- Align the mounting holes on the drive motor and reducer with the ones on the wheel carrier.
- Fit the flat surface of the gasket to the mounting surface (if a gasket is required), apply Loctite 272 threadlocking adhesive, then install the bolts one by one.
- Tighten the bolts to the specified torque with a torque wrench.
- Reconnect the electrical harness.
- Install the tire and wheel assembly as needed.

Steering Cylinder

WARNING

- Before loosening or disassembling hydraulic parts, the hydraulic pressure of all hydraulic lines should be released and the hydraulic oil should completely cool down.**
- Disassemble the hydraulic components slowly to prevent the hydraulic oil from splashing and injuring people.**

- Make sure the machine is in stowed position.
- Place a jack of sufficient capacity under the chassis to support the chassis.
- Mark and disconnect the hydraulic pipelines on the steering cylinder and collect the hydraulic oil in the pipelines with a suitable vessel. Then seal the pipelines and ports.
- Support the steering cylinder with suitable lifting equipment.
- Remove the retainer ring and pivot pin securing the steering cylinder with the steering connecting rod.
- Remove the bolts securing the steering cylinder to the chassis.
- Slowly remove the steering cylinder with the aid of the lifting equipment.

WARNING

When disassembling the cylinder, use caution to prevent it from falling and getting damaged, and also to avoid impacts that could lead to high-pressure oil leaks.

Installation

- Place a jack of sufficient capacity under the chassis to support the chassis.
- Align the mounting hole on the steering cylinder with that on the chassis.
- Apply Loctite 272 threadlocking adhesive, and then install the bolts one by one.
- Tighten the bolts with a torque wrench according to the specified torque.
- Reinstall the retainer ring and pivot pin securing the steering cylinder with the steering connecting rod.
- Connect the hydraulic hoses.

7.2 TIRE ASSEMBLY

Checking Tires and Rims

Maintaining the tires and rims is essential for the normal and safe operation of the machine. The machine may tip over if a tire or a rim fails, so check the tires and rims each time before operating the machine and repair defective tires and rims in a timely fashion.

This machine is equipped with solid tires that do not need to be inflated.

- Check each tire for cuts, cracks, punctures and abnormal wear. Replace the tire if necessary.
- Check each rim for damage, deformation or cracked welds. Replace the rim if necessary.

Checking Wheel Nuts

The wheel nuts should be tightened before the machine is put into service for the first time and after each tire is removed. Check and tighten the wheel nuts to the specified torque every 3 months or 250 operating hours.

Replacement Requirements

WARNING

- The tires and rims on the machine have been designed and selected according to the overall performance and load stability requirements of the machine. Therefore, the model specifications, rim width, installation center surface, diameter, etc. must not be changed, otherwise this could lead to an unstable and hazardous condition.
- Wheel-specific nuts must be used that match the wheel bolts. The wheel nuts must be installed and maintained with the proper tightening torque to prevent loose rims, broken bolts and wheels loosening from the axle. Be sure to only use nuts that match the mounting angle of the rim holes.

Hunan Sinoboom Intelligent Equipment Co., Ltd. recommends the replacement tire be of the same size, ply rating and brand as the original tire. For the tire part numbers of specific machine models, please refer to the Parts Manual of the corresponding machine. If you choose not to use the replacement tires recommended by Hunan Sinoboom Intelligent Equipment Co., Ltd., the following specifications should be adhered to:

- The ply rating/rated load capacity and size should be the same as the original tire or superior to it.
- The tire tread contact width should be the same as or superior to the original tire.
- The wheel diameter, width and offset dimensions must be the same as the original tires.
- The replacement tire must be approved for the application by the tire manufacturer (including intended purpose, maximum travel speed, maximum tire load, etc.).
- Due to size differences between different tire brands, both tires on the same axle should be of the same brand.

NOTICE

Unless specifically approved by Sinoboom, do not replace foam-filled tires with pneumatic tires.

Replacing Tire and Wheel Assembly

WARNING

Tighten the wheel nuts to the specified torque to prevent the wheel from loosening. Use a torque wrench to tighten the nuts. If no torque wrench is available use a socket wrench to tighten the nuts and then immediately have a service station or dealer tighten the nuts to the specified torque. Over-tightening will cause the nuts to break or permanently deform the bolt holes in the rims.

The correct steps to replace a tire and wheel assembly are as follows:

1. Make sure the machine is in stowed position.
2. Press the main power switch/pull out the main power handle and disconnect all power sources (such as battery charger) from the machine.
3. Use a jack with sufficient load capacity to lift the machine to the appropriate height so that the wheel assembly is off the ground.
4. Use suitable lifting equipment to safely support the tire and wheel assembly.
5. Remove the fasteners alternately, and then remove the wheel.
6. Align the mounting holes of the new wheel with the corresponding mounting holes on the hub,, fit the flat surface of the gasket to the mounting surface (if gaskets are used). After applying Loctite 272 threadlocking adhesive to the bolts, install the bolts in sequence, and tighten the bolts diagonally to the torque specified in **Torque Specifications** .
7. Remove the jack as needed after installation.

7.3 CHASSIS WEAR PADS

The chassis wear pads connecting with the scissor arm is essential for the safe operation of the machine. As a friction pair will develop between the wear pad and the grooved steel surface of chassis while the platform is elevating or lowering. Improper wear pads or continued use of extremely worn wear pads may result in component damage and unsafe operation. It is recommended to check the chassis wear pad thickness once a year or after 1000 hours of operation.

1. Raise the platform appropriately to perform the following measurement.
2. As shown below, measure the distance from the bottom surface of each wear pad at the scissor arm sliding end to the center of the mounting axle hole.
3. Compare the measured value with the reference distance (L) below. If the difference is greater than 3

mm (0.118 in) (i.e the wear extent of wear pad exceeds 3 mm [0.118 in]), replace the wear pad immediately.

NOTICE

If the wear pad on one side is excessively worn, the wear pads on both sides must be replaced together.

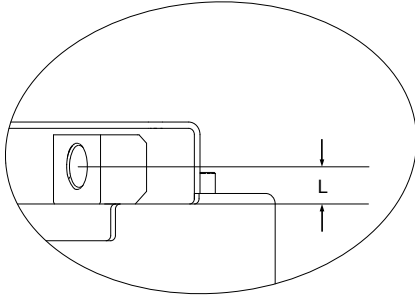


Fig. 2

L = 40 mm (1.6 in)

7.4 POWER UNIT

Disassembly

WARNING

- Before loosening or disassembling hydraulic parts (especially the counterbalance valve on the cylinder), the hydraulic pressure of all hydraulic lines should be released and the hydraulic oil should completely cool down.
- Disassemble the hydraulic components slowly to prevent the hydraulic oil from splashing and causing injuries.

1. Open the right chassis door and locate the power unit.
2. Mark and disconnect the harness connections in the power unit.
3. Mark and disconnect the hydraulic lines from the power unit and collect the hydraulic oil from the lines with a suitable container. Plug the lines and the ports.
4. Dismount the fasteners at the bottom of power unit.
5. Slowly remove the power unit with the aid of the lifting equipment.

Installation

For installation, follow the disassembly procedure in reverse order.

7.5 BATTERY

WARNING

- Before removing the battery, the charger power supply and the entire machine's operating power must be cut off.
- The battery case may only be disassembled by qualified/authorized personnel; improper work may result in system damage.

1. Place the machine in a ventilated and spark-free environment.
2. Open the left chassis compartment to locate the battery.
3. Mark and disconnect the wire harness connection on the negative terminal of the battery, then disconnect the wire harness connection on the positive terminal of the battery.
4. After securing the battery with slings, remove the battery from the machine using suitable lifting equipment.

8 HYDRAULIC SYSTEM

The machine's hydraulic system can be viewed as consisting of two parts: one part is used for the steering function, the other part for the platform lifting/lowering functions.

The motor drives the hydraulic pump that transfers hydraulic oil to the function valve blocks, which are equipped with directional valves for the control of different movements. To protect components and to avoid overpressure, the valve blocks are equipped with over-flow valves.

Proper maintenance of the hydraulic system is essential for the proper and safe operation of the machine. Failure to maintain the hydraulic components in a timely fashion may lead to component damage, which can affect the safe operation of the machine.

8.1 FUNCTION VALVES

Lift Control Manifold (PN.202040003321)

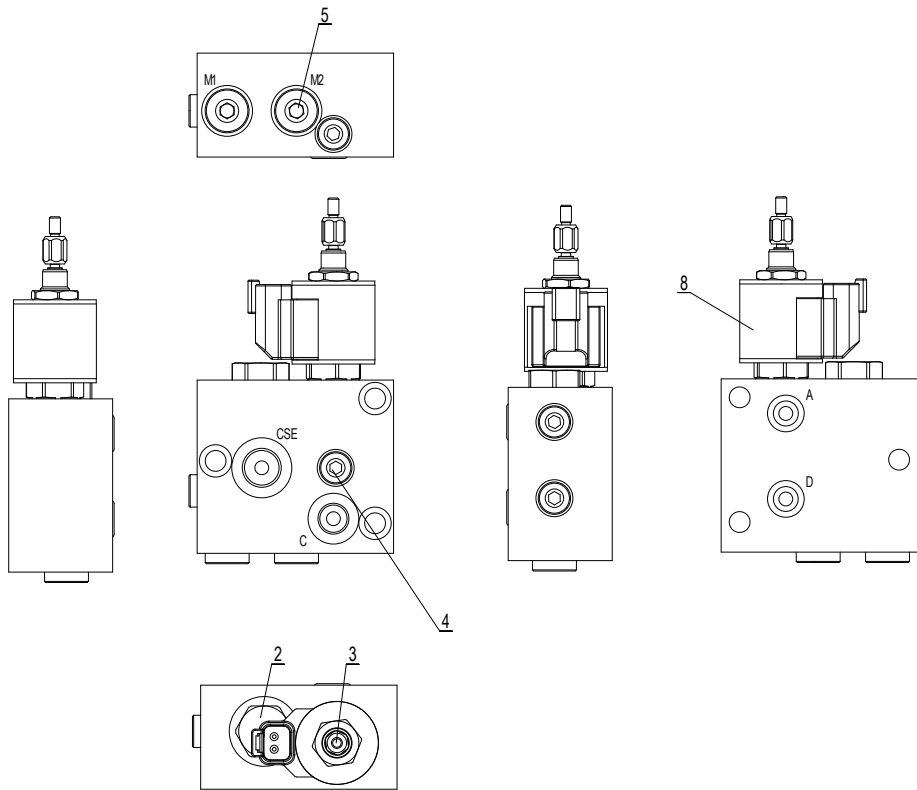


Fig. 1

Table 8-1

No.	Description	Installation torque	Function
2	Check valve	27 Nm (20 ft-lb)	Keeps oil flowing in one direction
3	Solenoid valve	27 Nm (20 ft-lb)	Control the turn-on and turn-off of oil lines
4	Damper	2 Nm (1.5 ft-lb)	/
5	Damper	2 Nm (1.5 ft-lb)	/

Lift Control Manifold (PN.202040000305) – 1000176

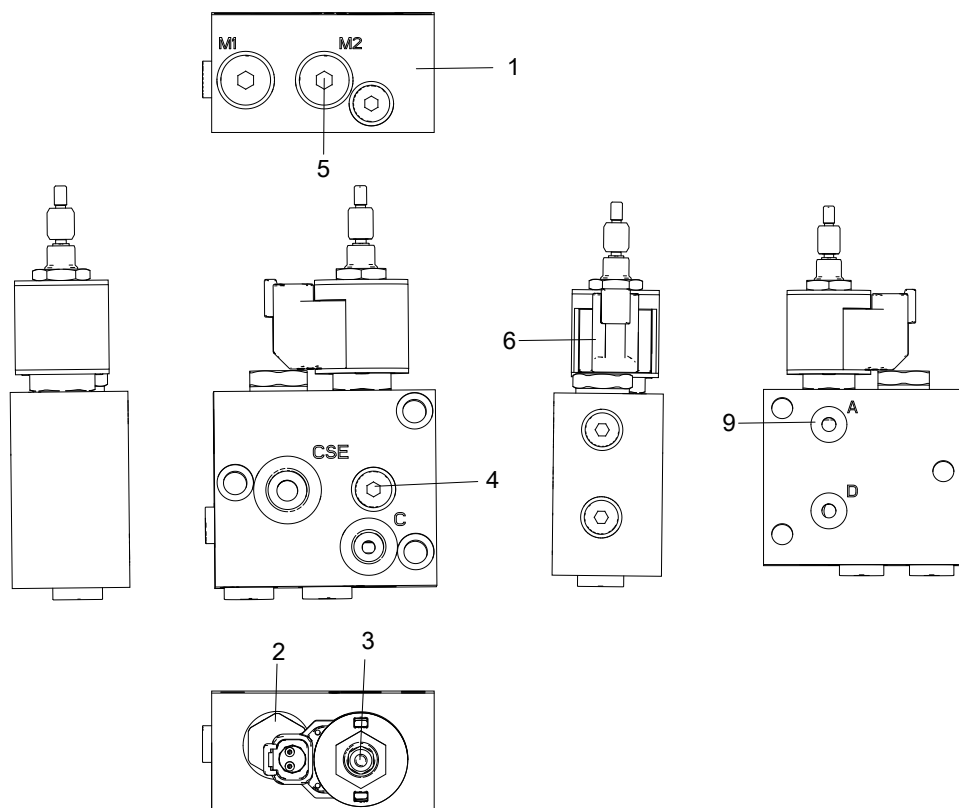


Fig. 2

Table 8-2

No.	Description	Installation torque	Function
2	Check valve	22 Nm (16 ft-lb)	Keeps oil flowing in one direction
3	Solenoid valve	22.2 Nm (16 ft-lb)	Control the turn-on and turn-off of oil lines
4	Damper	4 Nm (3 ft-lb)	/
5	Throttle screw	4 Nm (3 ft-lb)	/

Lift Control Manifold (PN.202040000305) – 1000851

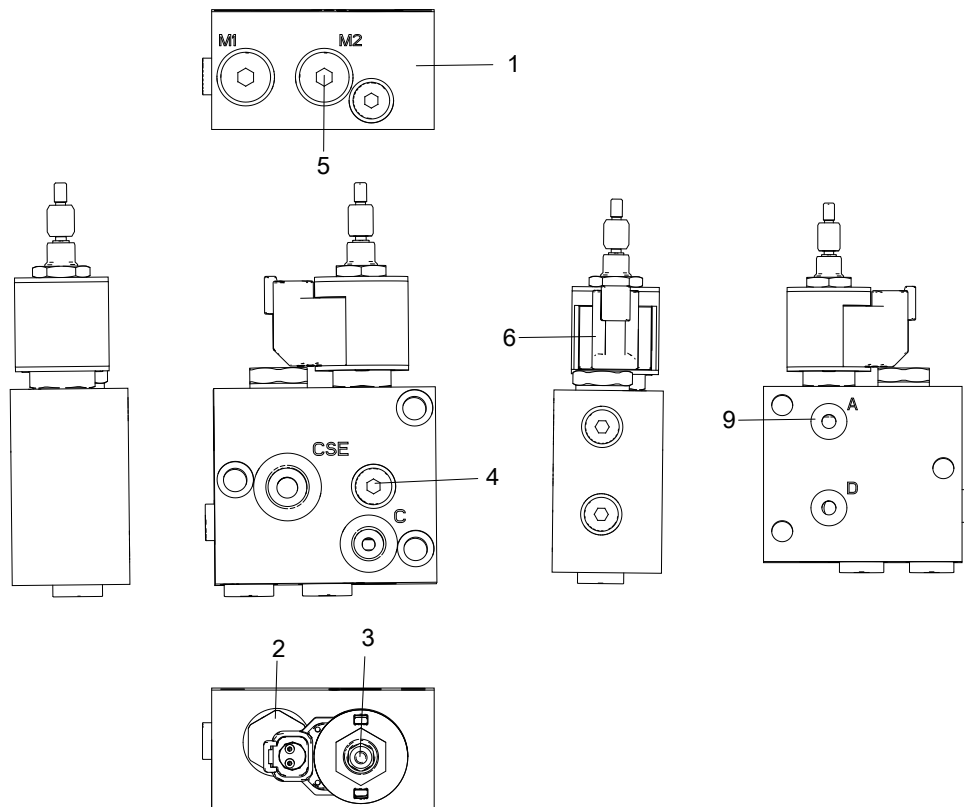


Fig. 3

Table 8-3

No.	Description	Installation torque	Function
2	Check valve	27 Nm (20 ft-lb)	Keeps oil flowing in one direction
3	Solenoid valve	27 Nm (20 ft-lb)	Control the turn-on and turn-off of oil lines
4	Damper	/	/
5	Damper	2 Nm (1.5 ft-lb)	/

8.2 POWER UNIT

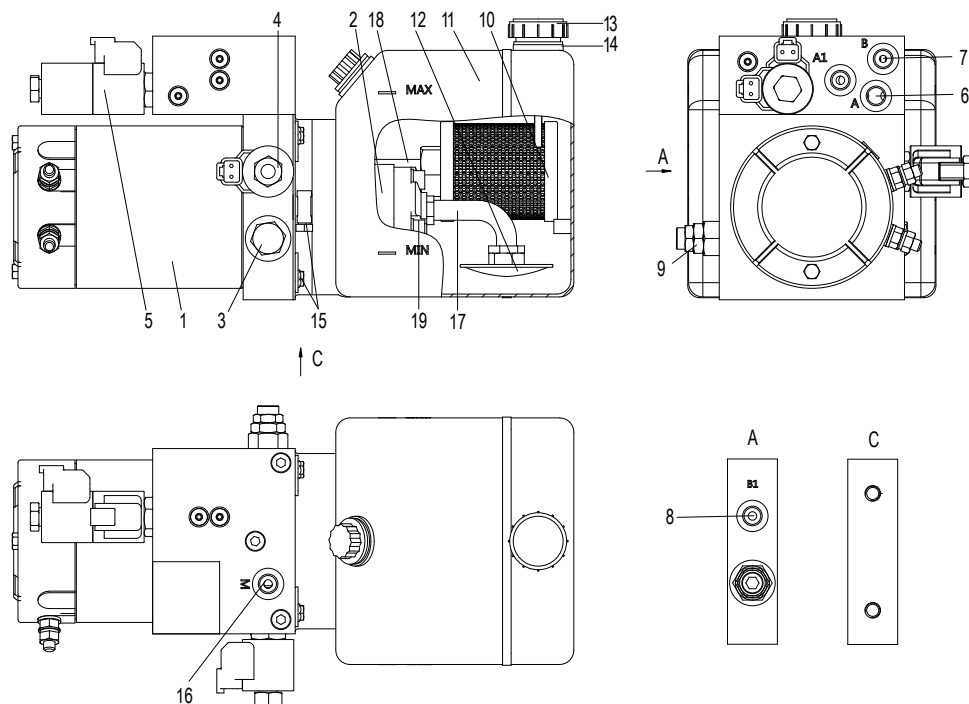


Fig. 4 Diagram of Power Unit Structure – 1000106

Table 8-4 Description of Power Unit Structure

1. DC motor	2. Gear pump	3. Check valve
4. 2-position 4-way solenoid valve	5. 3-position 4-way solenoid valve	9. Overflow valve
10. Return filter	11. Hydraulic tank	12. Suction filter screen
13. Air filter	14. Oil drain port	15. Hydraulic tank fasteners (bolt, clamp)
16. Pressure measuring port	17. Oil suction tube	18. Oil return tube
19. Hydraulic pump fasteners		

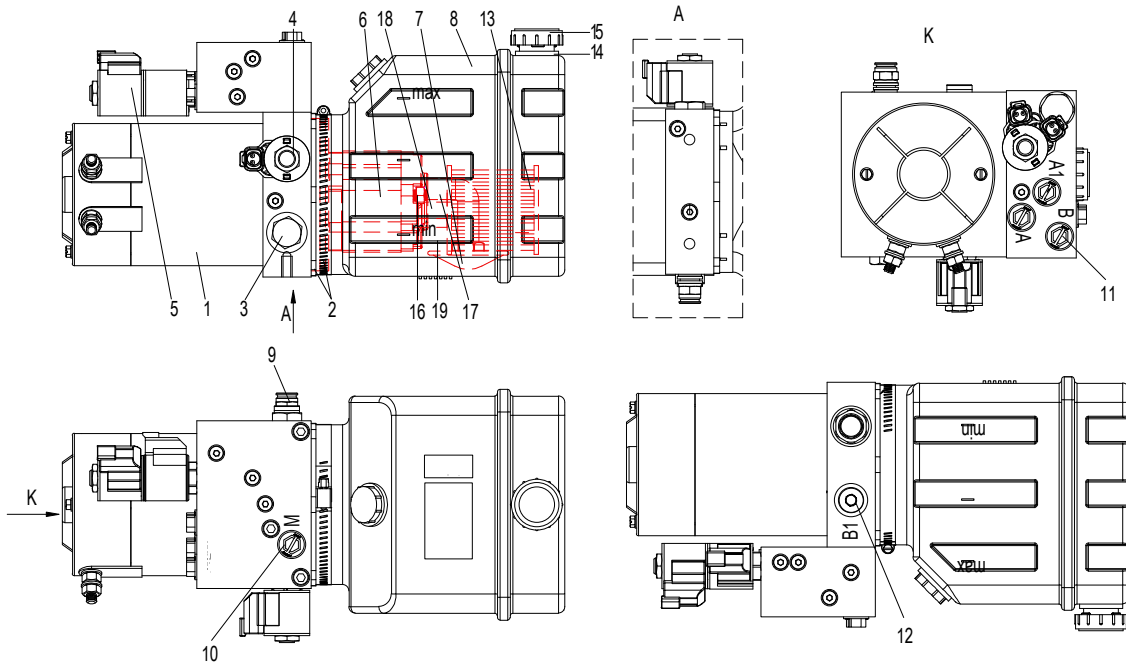


Fig. 5 Diagram of Power Unit Structure – 1000631

Table 8-5 Description of Power Unit Structure

1. DC motor	2. Hydraulic tank fasteners (screw, clamp)	3. Check valve
4. 2-position 4-way solenoid valve	5. 3-position 4-way solenoid valve	6. Gear pump
7. Suction filter screen	8. Hydraulic tank	9. Overflow valve
10. Pressure measuring port	13. Return filter	14. Oil drain port
15. Air filter	16. Hydraulic pump fasteners	17. Oil suction tube
18. Return filter tube	19. Oil return tube	

Function Valves

The function valves shown in the power unit assembly above serve the following purposes:

Table 8-6

No.	Description	Installation torque	Function
3	Check valve	/	Keeps oil flowing in one direction
4	2-position 4-way solenoid valve	34 Nm (25 ft-lb)	Controls platform up/down movements
5	3-position 4-way solenoid valve	9 Nm (7 ft-lb)	Controls wheel steering left/right
9	Overflow valve	27 Nm (20 ft-lb)	Prevents system overpressure

Regulating the Pressure of System Overflow Valve

1. Install a pressure test connector at the pressure diagnostic port of the power unit.

2. Use a pressure gauge (range of 25 MPa [3626 psi]) to connect to the pressure test connector.
3. Switch the ground/platform control selector switch on the ground controller to the platform control position and pull out the emergency stop switches on the ground controller and platform controller.
4. Perform a steering action using the platform controller handle to turn the wheels into position. Record the pressure reading on the pressure gauge at this time.
5. If the pressure value is correct (for the specified pressure value, please refer to the **Pressure Settings**), the system overflow valve requires no pressure adjustment.
6. If the measured values do not match the specified values, the pressure of the system overflow valve needs to be adjusted as follows:
 - Use a wrench to hold the overflow valve and loosen the nut.
 - Adjust the overflow valve pressure with a wrench. Turn clockwise to increase overflow valve pressure, turn counterclockwise to decrease the overflow valve pressure. Repeat until the pressure gauge reads the specified value.
 - Hold the overflow valve with a hex wrench and tighten the nut on the valve.
 - Repeat Step 4 to verify the pressure.

NOTICE

If the pressure value does not change, the hydraulic pump needs repair or replacement.

WARNING

- **Regulating the pressure improperly may cause machine damage and even serious injury. Do not set the pressure to values beyond the specified range.**
- **The hydraulic pump is not equipped with an overflow valve. Overpressure may result in damage. When adjusting the pressure, please be careful not to overpressurize the pump.**

7. Remove the pressure gauge and the pressure test connector.

Hydraulic pump

Inspection

Perform inspection on the hydraulic pump as per the instructions in **Regulating the Pressure of System Overflow Valve**.

Disassembly

WARNING

- **Before loosening or disassembling hydraulic parts (especially the counterbalance valve on the cylinder), the hydraulic pressure of all hydraulic lines should be released and the hydraulic oil should completely cool down.**
- **Disassemble the hydraulic components slowly to prevent the hydraulic oil from splashing and causing injuries.**

1. Open the right chassis door and locate the power unit.
2. Remove the power unit and place it in a suitable location.
3. Remove the hydraulic tank from the power unit.
4. Remove the oil return pipe connected to the hydraulic pump.
5. Remove the oil suction pipe connected to the hydraulic pump.
6. Remove the hydraulic pump fasteners, and slowly remove the hydraulic pump from the valve block.

NOTICE

Extra care should be taken during disassembly to avoid damaging component surfaces.

Installation

For installation, follow the disassembly procedure in reverse order.

Hydraulic Tank

Air Filter

It is recommended to clean the hydraulic tank air filter every 3 months or after 250 hours of operation, and replace it every 6 months or after 500 hours of operation. The replacement interval should be shorter in harsh operating environments.

The steps to check and clean the air filter are as follows:

1. Turn off the machine.
2. Open the right door of the chassis, locate the air filter on the top of the hydraulic tank.
3. Remove the air filter.

4. Check the hydraulic tank air filter: air should pass through the air filter smoothly.
5. If the air cannot pass through the air filter smoothly, clean the air filter with a neutral solvent and dry it using an air gun.
6. Check the air filter again, repeat as necessary until the air passes through the filter smoothly.
7. Install the air filter back onto the tank.
8. Clean up any hydraulic oil that was spilled during the process.
9. Start the machine from the ground.
10. Check the return filter and related components for leakage.

Suction Filter Screen

It is recommended to replace the suction filter screen every year or after 1000 hours of operation. The replacement interval should be shorter in harsh operating environments.

NOTICE
<i>Remove the hydraulic tank before replacing the suction filter screen.</i>

Every time the hydraulic oil is replaced, the suction filter screen should also be replaced.

Return Filter

The return filter of the hydraulic oil tank cannot be replaced separately. Instead, the complete filter needs to be replaced.

It's recommended to replace the hydraulic tank return filter every year or after 1000 operating hours. The replacement interval should be shorter in harsh operating environments.

NOTICE
<i>Remove the hydraulic tank before replacing the hydraulic tank return filter.</i>

8.3 HYDRAULIC OIL

Checking Oil Level

Maintaining the hydraulic oil at a proper level is essential for the normal operation of the machine. If the hydraulic oil level is too high, oil will overflow from the tank during operation. If the hydraulic oil level is too low the oil pump will suck in air during operation, which will lead to component damage.

1. Make sure the platform is in stowed position.
2. Open the right chassis door and visually inspect the side of the hydraulic tank. The hydraulic oil level should be between the MAX scale line and the third (from top to bottom) scale line on the tank.
3. If necessary, fill the tank through the oil drain port with suitable hydraulic oil according to the **Oil Specifications**, never overfill the tank.
4. Check the hydraulic tank and fittings for leakage.

Checking the Cleanliness of the Hydraulic Oil

Check the hydraulic oil. If any of the following conditions are observed the hydraulic oil must be replaced.

- The hydraulic oil is milky white and cloudy.
- The hydraulic oil is black.
- Check a small sample of the hydraulic oil using a bright source of light to see if there are reflections of metal particles or rub the hydraulic oil with two fingers to locate metal particles.
- The hydraulic oil has an unusual smell.

Changing the Hydraulic Oil

It is recommended to change the hydraulic oil every year or after 1000 hours of operation. The replacement interval should be shorter in harsh operating environments.

NOTICE
<i>Every time the hydraulic oil is replaced, the suction filter screen of the hydraulic tank must also be replaced.</i>

1. Turn off the machine and make sure the hydraulic oil has cooled to room temperature.
2. Open the right chassis door and locate the power unit.
3. Remove the power unit and place it in a suitable location.

4. Unscrew the hydraulic tank air filter and allow the hydraulic oil to drain from the drain port into a suitable container.
5. After all hydraulic oil has been drained completely, install the air filter.
6. Remove the fasteners on the side of the hydraulic tank, then remove the hydraulic tank from the power unit.

NOTICE

Be extremely careful while removing the hydraulic tank; the inside of the hydraulic tank and other components that are mounted to the power unit may get damaged.

7. After cleaning the inside of the tank with a neutral solvent, drain the solvent.
8. After the hydraulic tank is dry, reinstall it to the power unit.
9. Reinstall the power unit assembly into its position on the chassis.
10. Fill the tank through the oil drain port with suitable hydraulic oil according to the **Oil Specifications**, never overfill the tank.

8.4 ADJUSTING EMERGENCY LOWERING HANDLE

NOTICE

Perform this operation with the platform in an unloaded state.

1. Start the machine and raise the platform so that the safety strut can be fully erected.
2. Erect the safety strut and lower the platform as to ensure that the safety strut provides effective support.



WARNING

Do not place your hands or other parts of your body under the platform while it is being lowered.

3. Pull out the emergency lowering handle located on the rear of the chassis.
4. Measure the distance from the end of the handle to the mounting nut.
5. If the measured distance is less than or equal to 3 mm (0.12 in), proceed to step 7. If the measured

distance is greater than 3 mm (0.12 in), proceed to step 6.

6. Adjust the mounting nut so that the distance from the mounting nut is no more than 3 mm (0.12 in).
7. Start the machine and raise the platform so that the safety strut can be fully lowered. Lower the safety strut.
8. Pull the emergency lowering handle outward 2 to 3 times to ensure normal operation.

8.5 LUBRICATING OIL CYLINDER

Regularly lubricating the oil cylinder is quite important to keep the machine in normal working condition. It is recommended to lubricate the oil cylinder every 3 months or after 250 hours of operation.

1. Locate the grease nipple on the oil cylinder.
2. Remove the oil cap.
3. Wipe the grease nipple with clean cloth to remove dust.
4. Connect the grease gun to the grease nipple and fill with lubricating oil until a small amount of lubricating oil flows from the fitting or around the bearing.
5. Disconnect the grease gun.
6. Wipe off the spilled lubricating oil from the grease nipple or bearing.
7. Change the oil cap.

8.6 CYLINDER DRIFT INSPECTION

A drift of the cylinder is normal within a certain range. In order to ensure normal operation of the machine, it is recommended to conduct a drift inspection on the platform every 3 months or after 250 hours of operation to determine whether a drift inspection of the cylinder is required.

Raise the platform to the highest position, and place a weight equivalent to the rated load on the platform to measure the drift from the platform to the ground with the machine powered off. If the platform drifts down more than 50 mm (1.97 in) in 10 minutes, perform a cylinder drift inspection as per the following procedures.

1. Place the machine in an environment with stable ambient temperature.
2. Raise the platform to the highest position, and place a weight equivalent to the rated load on the platform.
3. Measure drift at the cylinder piston rod with a calibrated dial indicator.

- The maximum allowable drift for cylinders with different bores is shown in the table below. If the measured value is less than the maximum allowable drift, the cylinder is operating normally. If the measured value is greater than the maximum allowable drift the cylinder is not operating normally. Contact qualified service technicians for inspection and repair.

Table 8-7 Maximum allowable drift for different cylinder bore diameters

Cylinder bore diameter (mm/in)	Maximum allowable drift in 10 minutes (mm/in)
76/3	0.66/0.026
89/3.5	0.48/0.019
102/4	0.38/0.015
127/5	0.22/0.009
152/6	0.15/0.006
178/7	0.13/0.005

NOTICE

The data is based on a cylinder leakage value of 6 drops per minute. Since the hydraulic oil expands and contracts depending on temperature, the tolerance for the cylinder drift is up 7/10000 or 0.07 % for each temperature change of 1°C.

8.7 HYDRAULIC SYMBOLS

Table 8-8

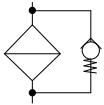
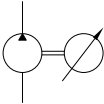

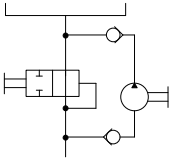
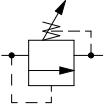
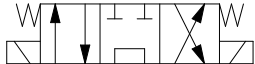
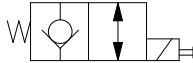
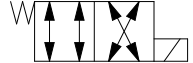
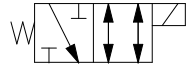
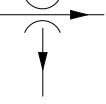

Symbols	Description
	Filter
	Power unit
	Hydraulic motor

Table 8-8 (continued)

Symbols	Description
	Manual brake release valve
	Overflow valve
	3-position 4-way solenoid directional valve
	2/2-way solenoid directional valve with manual override
	2-position 4-way solenoid directional valve
	Directional valve for traveling at high and low speed
	Priority flow valve
	Check valve

8.8 HYDRAULIC SCHEMATIC DIAGRAM

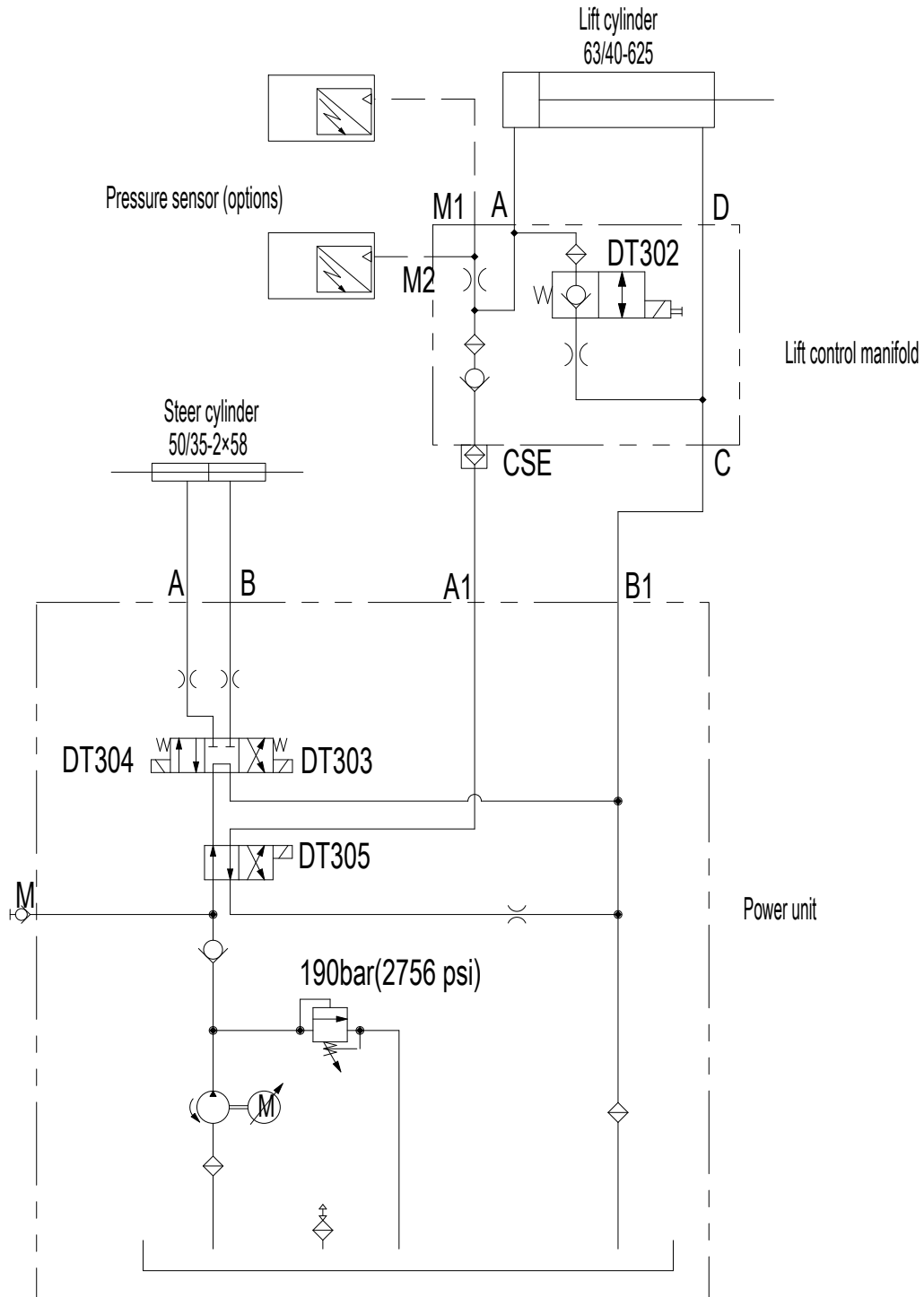


Fig. 6 Hydraulic Schematic Diagram

9

ELECTRICAL SYSTEM

Two 12 V lead-acid batteries in series or one 24V lithium battery are used to supply power to the drive motor and the lift motor to enable traveling, steering and platform lifting/lowering movements.

The batteries are charged via an external power source. A circuit breaker is used to protect the control system.

Proper maintenance of the electrical equipment is essential for the proper and safe operation of the machine. Continued operation of the machine with damaged or corroded electrical components may lead to unsafe situations or severe injuries.

9.1 BATTERY

There are three types of batteries that may be used in this machine: lead acid battery, lead acid maintenance-free battery, and lithium battery. The latter two batteries do not require maintenance.

Inspection

The battery condition will affect machine performance and operation. The following checks should be performed on the battery at specified intervals.

- Check the battery level. The battery should not be discharged by more than 80% of its total capacity, it should be charged immediately after each discharge.
- Check the wiring harness retaining nuts between the battery cells. Make sure that the retaining nuts are tightened with the correct torque. Refer to the **Torque Specifications** section for the tightening torques.
- Inspect the battery wire harness connections. Make sure that the battery harness connections are firmly secured and are free from corrosion. Positive and negative terminals must not be reversed.

NOTICE

Improper connection may result in reduced performance and damaged terminals, melting, or even fire.

- Check whether the inside and outside paint of the battery box shows any damage. If any damage is found, repair the paint immediately to protect the outer box insulation and to prevent corrosion.

- Check the battery compartment for accumulation of water. Clean up any accumulated water immediately.
- Clean the area around the battery regularly. Regularly clean the top of the battery, terminals, and connection points with a mixture of baking soda and water using a cloth or brush. After cleaning, promptly dry with a cloth and apply a thin layer of Vaseline or use terminal protectors. Do not allow the cleaning solution to enter the battery's interior.

NOTICE

Adding terminal protectors and anti-corrosion sealants will protect the battery terminals and cables from corrosion.

The instructions below are applicable only for batteries requiring maintenance: Before conducting the inspection, fully charge the battery and let it sit for 24 hours, allowing the battery cells to balance.

1. Wear protective clothing, protective gloves and protective glasses.
2. Remove the battery vent cover.
3. Top up the hydrometer and drain it two or three times, then take a sample of the battery electrolyte.
4. Measure the specific gravity of all battery cells in sequence and note down the readings.
5. If the ambient temperature is above 27 °C (80 °F), add 0.004 to the specific gravity reading for every increase of 5 °C (40 °F). If the ambient temperature is below 27 °C (80 °F), subtract 0.004 from the specific gravity reading for every decrease of 5 °C (40 °F).
 - Result 1: if the specific gravity reading of all battery cells is 1.250 or higher, and the reading difference between any two cells is less than 0.050 proceed with the next step.
 - Result 2: if the specific gravity reading of one or more battery cells is below 1.250, it indicates that the battery is running low and needs charging. After charging, measure the specific gravity reading; if it meets Result 1 proceed with the next step.
 - Result 3: If the specific gravity reading difference between any two cells in the battery pack exceeds 0.050, equalize the battery pack and let it sit for 6 hours before measuring the specific gravity again. If the readings match Result 1 proceed to the next step.

NOTICE

If Result 1 cannot be achieved even after several attempts the battery may be malfunctioning.

6. Check the battery electrolyte level. Make sure the electrolyte level is correct. Add distilled water as needed.
7. Install the battery vent cover.

Adding Fluid

NOTICE

- For lead-acid batteries (requiring maintenance), the electrolyte level should be checked after each charging. If the level is low, add water in time.
- The water shall be added after charging. Adding water before charging may cause acid overflow during charging.

- For batteries equipped with an automatic water refilling system, when the electrolyte is at the lowest level with the battery fully charged (the white dot in the battery observation opening is not at the top), add water immediately. It is recommended to use an automatic water refilling device for refilling. Correct steps for its application are as follows:
 1. Open the bucket cover of the refilling device.
 2. Add deionized water.
 3. Put the cover back on and connect the refilling plug.
 4. Connect the quick connector between the refilling device and the battery, and turn on the power switch to start automatic water refilling.
 5. After water refilling is completed, the automatic water refilling system will automatically stop.
 6. Turn off the power switch and disconnect the water refilling plug to complete the refilling process.
- If the battery is not equipped with an automatic refilling system, check the electrolyte level after charging. If the level is lower than the allowed minimum level (the white dot in the battery observation hole is not at the top), add suitable distilled water or deionized water to the standard level (1-2 cm above the minimal level of the water filler plug). Wear gloves during the process. Never add any acid solution.

Equalization

Equalization is the deliberate process of overcharging the flooded/wet battery after it has been fully charged. Equalize the battery only when its specific gravity is low (less than 1.25) or its specific gravity exceeds the scope (more than 0.030) after the battery is fully charged.

NOTICE

- Equalization can only be performed on flooded/wet batteries. Do not balance other types of batteries.
- To prevent battery damage, the battery must be equalized after a storage period of up to three months from the date of delivery.

1. Check the electrolyte level to ensure that it meets the specified requirements.
2. Verify that all vent caps are properly secured to the battery.
3. Set the charger to equalization mode.
4. Charge the battery in equalization mode. The battery will bleed air in the equalization process (forming bubbles).
5. Remove the vent cap every hour to measure the specific gravity of all battery cells, stop charging in equalization mode if the specific gravity doesn't increase any further.

Storage

- Fully charge the battery before placing the machine into storage.
- The battery should be stored in a cool and dry environment (temperature 10°C-25°C/50-77°F, RH < 90 %). Charge the battery every 3 months using the charger provided by the manufacturer.
- Switch off the main power switch and the emergency stop button to eliminate potential hazards associated with electrical leakage.
- The battery will self-discharge gradually during storage. Monitor the specific gravity or the voltage every 4 ~ 6 weeks. The equivalent values of the state of charge, specific gravity and open-circuit voltage are shown in the following table.

Table 9-1

State of charge (%)	Specific gravity	Open-circuit voltage (V)		
		Battery cell	6V	12V
100	1.277	2.122	6.37	12.73
90	1.258	2.103	6.31	12.62
80	1.238	2.083	6.25	12.50
70	1.217	2.062	6.19	12.37
60	1.195	2.040	6.12	12.24
50	1.172	2.017	6.05	12.10
40	1.148	1.993	5.98	11.96
30	1.124	1.969	5.91	11.81
20	1.098	1.943	5.83	11.66
10	1.073	1.918	5.75	11.51

- Recharge the battery in quick charging mode when the battery level is 70 % or lower.
- Recharge the battery before use after taking it out of storage.
- Storage in hot environments (above 32°C/90°F): Avoid exposing the battery to heat sources during storage since the battery self-discharges faster at higher temperatures. If it's necessary to store the battery at higher temperatures monitor the specific gravity or voltage more frequently (approximately every 2 to 4 weeks).
- Storage in cold environments (below 0°C/32°F): Avoid storing the battery in locations that may be exposed to freezing temperatures since the battery may freeze if not fully charged. If the battery is to be stored in cold environments it must be fully charged.

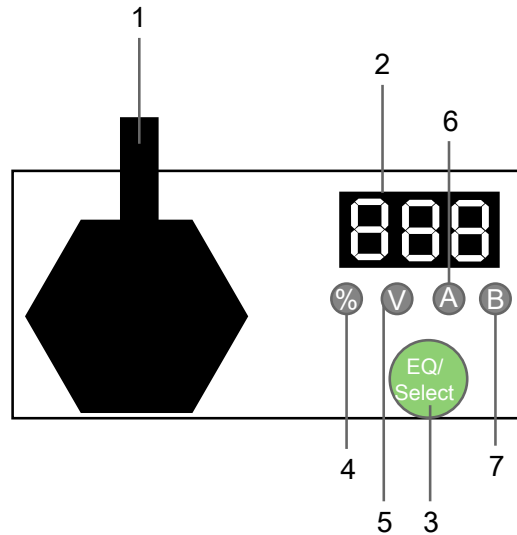


Fig. 1

NOTICE
Do not store the battery longer than 6 months in hot or cold environments.

Table 9-2

No.	Description
1	Battery program update interface (if equipped)
2	Digital display
3	EQ/Select key
4	Capacity indicator light
5	Charging voltage indicator
6	Charging current indicator
7	Battery voltage indicator

Change the curve:

9.2 CHANGING THE CHARGING CURVE

Note: The charging curve of the charger for lithium batteries does not require any settings, so the following instructions apply to the charger for lead-acid batteries only.

NOTICE

The default curve code of the charger is b48. Please select an appropriate charging curve code for your machine as per the battery requirements in the **Technical Characteristics** section in this manual.

1. Press and hold the Select key for 5 sec until the screen displays the current charging curve code.
2. Press and hold the key for 1 sec to change the charging curve code.
3. After selecting the charging curve code, press and hold the Select key for 5 sec until the charging curve code flashes quickly, and the charging curve will be set.

4. Repeat the steps above if you wish to change the charging curve again.

Enter EQ mode manually:

1. Press and hold the select key for 10 sec until the letters EQ flash rapidly on the screen; this means the charger enters the EQ mode.
2. To exit the EQ mode, press and hold the select key for 10 sec until the word OFF flashes rapidly on the screen, this means the charger will exit the EQ mode.

9.3 ELECTRICAL SYMBOLS

Table 9-3

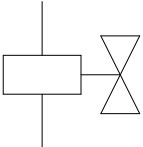
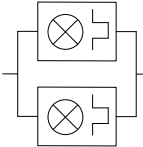
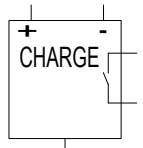
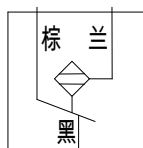
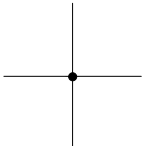
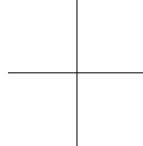
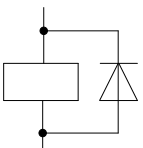
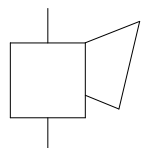
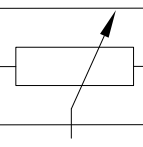
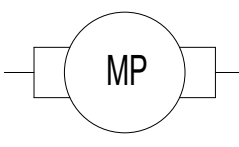
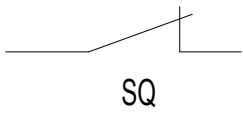
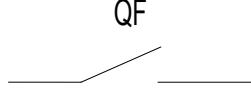
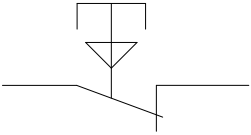
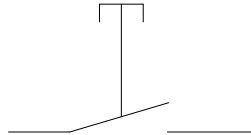
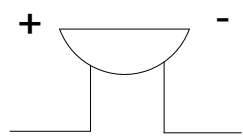
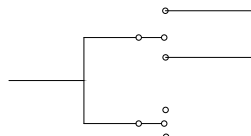
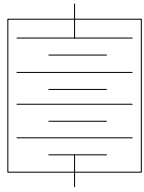

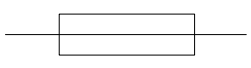
Symbols	Description	Symbols	Description
	Solenoid coil		Warning light
	Charger		Level switch
	Two lines, connected		Two lines, not connected
	Relay		Horn
	Sensor		Pump-controlled motor

Table 9-3 (continued)

Symbols	Description	Symbols	Description
 <p>SQ</p>	Limit switch	 <p>QF</p>	Main power switch
	Emergency stop button		Button
 <p>+ -</p>	Buzzer		Key switch
	AGM battery	 <p>+ Li -</p>	Lithium battery
	Fuse		

9.4 ELECTRICAL SCHEMATIC DIAGRAM

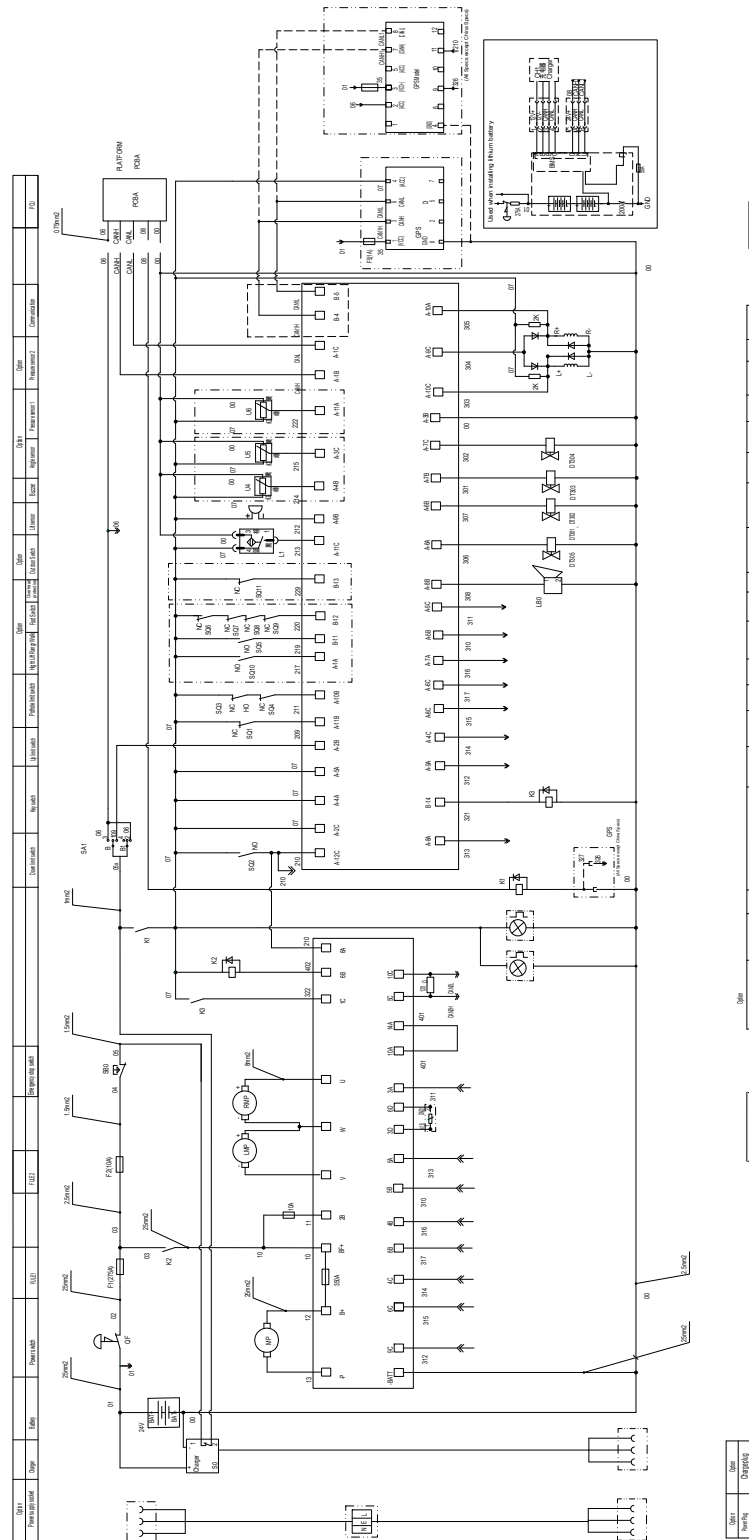


Fig. 2 Electrical Schematic Diagram (ZAPI Electric Motor Controller)

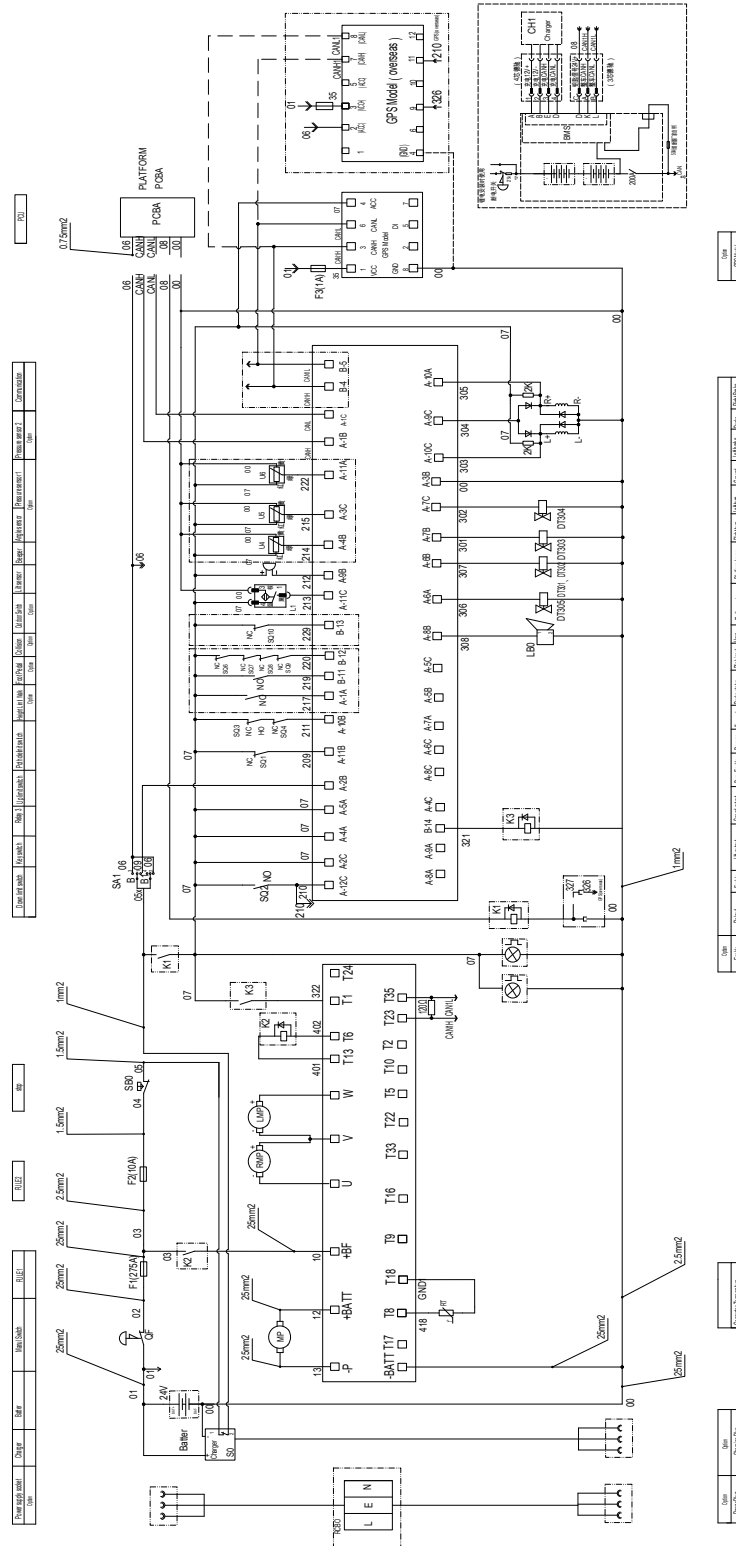


Fig. 3 Electrical Schematic Diagram (Curtis Electric Motor Controller)

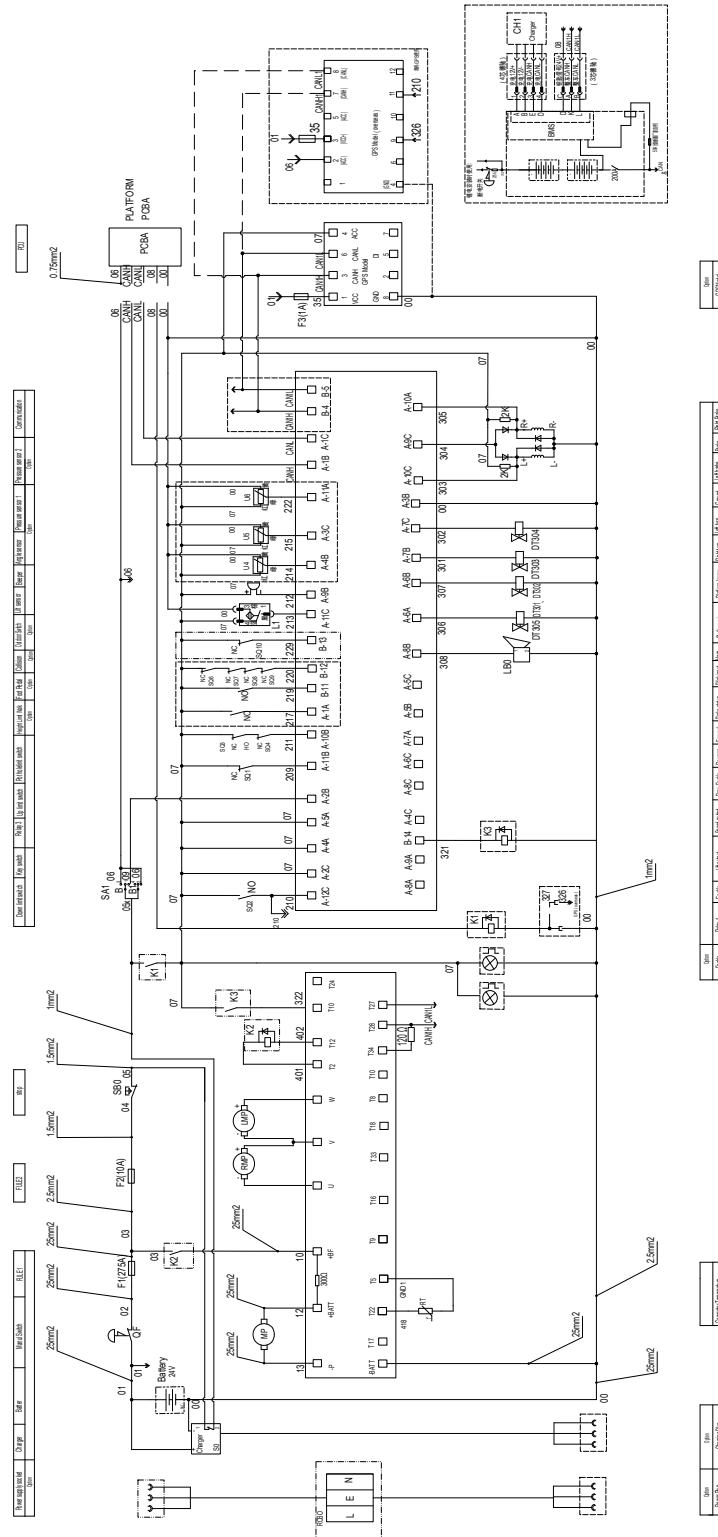


Fig. 4 Electrical Schematic Diagram (Qiantuo Electric Motor Controller)

10 TROUBLESHOOTING GUIDE

10.1 FAULT CODES DESCRIPTION

Machine Faults and Solutions

The machine has a display screen at the ground controller and platform controller respectively for displaying machine parameter information and fault types.

Table 10-1 Machine Faults and Solutions (Sinoboom Control System)

Code	Description	Restricted functions	Recommended solution
01	System Initialization Failure	All functions	Possible ECU error, please consider replacing the ECU.
02	System Communication Failure	All functions	Check the connection of the communication line for the upper and lower platforms. If this does not solve the problem, please try to replace the PCU or the ECU.
04	Drive heartbeat lost	All functions	Check the connections between the MC and ECU, check that the configuration options of the MC in the ECU are correct. If this does not solve the problem, please try to replace the MC.
06	Multi-angle Sensor Heartbeat Lost	All functions	Check whether the wiring between the multi-angle sensor terminal and the ECU terminal is disconnected. Also check that the multi-angle sensor terminal configuration options are correct. If this does not solve the problem, please try to replace the multi-angle sensor.
07	Platform Highest Position Warning OH	Lift and travel	Check the communication lines for short or open circuits, and check whether the relevant parameter settings are correct.
08	Multi-angle Sensor Fault	All functions	Check whether the wiring between the multi-angle sensor terminal and the ECU terminal is disconnected. Also check that the multi-angle sensor terminal configuration options are correct. If this does not solve the problem, please try to replace the multi-angle sensor.
09	GPS Communication Fault	All functions	Check the communication line between the GPS and ECU. If the problem still exists, check the connection or replace the GPS module.
10	Indoor Models – Activating Outdoor Mode Fault	All functions	Switch outdoor mode to indoor mode
12	Power-up ECU Key Fault	Limits all operations on the ECU	Check whether any ECU buttons have been pressed or pushed-down. If this does not solve the problem, please try to replace the ECU.
18	Pothole Guard Fault	Lift and travel	Carry out checks in the following sequence: <ul style="list-style-type: none"> • Check whether the pothole guard plate is deployed into its normal operating position;

Table 10-1 Machine Faults and Solutions (Sinoboom Control System) (continued)

Code	Description	Restricted functions	Recommended solution
			<ul style="list-style-type: none"> • Check whether the pothole guard plate limit switch and its wiring are in good operating condition; • Check whether the lower limit switch and its wiring are in good operating condition, and check whether the lower limit device is functioning normally.
20	BMS Fault	Lift and travel	Check the connection of the communication line between the ECU and BMS. If this does not solve the problem, please contact Sinoboom aftersales staff.
21	Lithium Battery Excessive Discharge Temperature Fault 1	Alarm only	Discharge Temperature Level-1 Fault: Inform the BMS factory to check battery temperature, or contact the Sinoboom aftersales staff.
22	Lithium Battery Discharge Current High Fault 1	Alarm only	Discharge Current High Fault 1: Inform the BMS factory to check battery current, or contact the Sinoboom aftersales staff.
23	Lithium Battery Total Voltage Low 1	Lift limited, travel restricted to low speed	Total Voltage Low Fault 1: Inform the BMS factory to check battery voltage, or contact the Sinoboom aftersales staff.
24	Lithium battery Cell Voltage Low Fault 1	Lift limited, travel restricted to low speed	Cell Voltage Low Fault 1: Inform the BMS factory to check battery voltage, or contact the Sinoboom aftersales staff.
25	Total Machine Voltage Low 2	Lift and travel	Cell Voltage Low Fault 2: Inform the BMS factory to check battery voltage, or contact the Sinoboom aftersales staff.
26	Large Difference in Voltage	Lift and travel	Inform the BMS factory to check battery voltage, or contact the Sinoboom aftersales staff.
27	Large Difference in Temperature	Lift and travel	Inform the BMS factory to check battery temperature, or contact the Sinoboom aftersales staff.
28	Discharge Current High 2	Lift and travel	Discharge Current High Fault 2: Inform the BMS factory to check battery current, or contact the Sinoboom aftersales staff.
29	Discharge Temperature High 2	Lift and travel	Discharge Temperature Fault 2: Inform the BMS factory to check battery temperature, or contact the Sinoboom aftersales staff.
30	GPS Lock 1	Alarm only	Please contact Sinoboom aftersales staff.
31	Pressure Sensor 1 Fault	All functions	Check whether the sensor and its wiring are in normal operating state. Check that the ECU sensor configuration options are correct. If this does not solve the problem, please try to replace the sensor.
32	Angle Sensor Fault	All functions	Check whether the sensor and its wiring are in normal operating state. Check that the ECU sensor configuration options are correct. If this does not solve the problem, please try to replace the sensor.
33	PCU Key Fault	All functions	Check whether any PCU buttons have been pressed or pushed down during the start-up procedure. If this does not solve the problem, please try to replace the PCU.

Table 10-1 Machine Faults and Solutions (Sinoboom Control System) (continued)

Code	Description	Restricted functions	Recommended solution
35	Pressure Sensor 2 Fault	All functions	Check whether the sensor and its wiring are in normal operating state. Check that the ECU sensor configuration options are correct. If this does not solve the problem, please try to replace the sensor.
36	Low battery level alarm	Lift limited, travel restricted to low speed	Shows that battery charge is low, charge the battery immediately.
38	GPS Lock 2 pre-warning	Alarm only	Please contact Sinoboom aftersales staff.
39	GPS Lock 2	Lift	Please contact Sinoboom aftersales staff.
40	GPS Lock 3 pre-warning	Alarm only	Please contact Sinoboom aftersales staff.
41	GPS Lock 3	All functions	Please contact Sinoboom aftersales staff.
42	Left turn button of the handle was pressed when turning on the power.	Alarm only	Check whether the left turn button has been erroneously pushed or pressed. If this does not solve the problem, please try to replace the handle or PCU.
43	Right turn button of the handle was pressed when turning on the power.	Alarm only	Check whether the right turn button has been erroneously pushed or pressed. If this does not solve the problem, please try to replace the handle or PCU.
45	Excessive Difference in Oil Pressure	Lift and travel	Check whether the oil pressure sensor is installed properly. Check whether the oil pressure sensor configuration options in the ECU are correct. If this does not solve the problem, please try to replace the oil pressure sensor.
46	Platform Enable Switch ON at Power-up	Limits all operations on the PCU	Check whether any enable switches have been pressed or pushed-down erroneously. Check whether the zero parameter settings are correct. If this does not solve the problem, please try to replace the handle or PCU.
47	Joystick Not In Neutral at Power-up	Lift and travel	Check whether the handle is in the zero position (vertical position). Check whether the zero position parameter settings are correct. If this does not solve the problem, please try to replace the handle or PCU.
50	Input-output Comparison Error	Lift and travel	Check whether the circuits at each sensor end and ECU end are open or short-circuited. Check whether the relevant parameters are turned on or off. If this does not solve the problem, please try to replace the ECU.
52	Forward Solenoid Valve Fault (Hydraulic Drive)	Lift and travel	Check whether the wiring of the solenoid valve is correct. If this does not solve the problem, please check the coil valve for open or short circuit. If this still does not solve the problem, please try to replace the solenoid valve.
53	Reverse Solenoid Valve Fault (Hydraulic Drive)	Lift and travel	Check whether the wiring of the solenoid valve is correct. If this does not solve the problem, please check the coil valve for open or short circuit. If this still does not solve the problem, please try to replace the solenoid valve.

Table 10-1 Machine Faults and Solutions (Sinoboom Control System) (continued)

Code	Description	Restricted functions	Recommended solution
54	Lift Up Coil Fault	Lift and travel	Check whether the wiring of the solenoid valve is correct. If this does not solve the problem, please check the coil valve for open or short circuit. If this still does not solve the problem, please try to replace the solenoid valve.
55	Lift Down Coil Fault	All functions	Check whether the wiring of the solenoid valve is correct. If this does not solve the problem, please check the coil valve for open or short circuit. If this still does not solve the problem, please try to replace the solenoid valve.
56	Right Turn Coil Fault	Lift and travel	Check whether the wiring of the solenoid valve is correct. If this does not solve the problem, please check the coil valve for open or short circuit. If this still does not solve the problem, please try to replace the solenoid valve.
57	Left Turn Coil Fault	Lift and travel	Check whether the wiring of the solenoid valve is correct. If this does not solve the problem, please check the coil valve for open or short circuit. If this still does not solve the problem, please try to replace the solenoid valve.
68	Low Voltage Alarm	All functions	Shows that battery voltage is low, charge the battery immediately. If the problem is not solved after fully charging the battery, please try to replace the battery.
69	High Zero Current Fault (Only Zapi)	Lift and travel	When the brake is active, the motor should stop turning, and should have no current. However, if the MC receives a fault message that the brake is active while the motor is turning, this fault will occur. This fault generally appears before other errors. If this error disappears after solving other errors, it can be ignored. If this fault persists, please try replacing the motor or MC.
70	Steering Input Out of Range (Only Zapi)	Lift and travel	Means that the steering input voltage of the ZAPI motor controller is outside the specified range. Please change the relevant parameters of the ZAPI motor controller to solve the problem.
71	Motor Controller Main Contactor Fault	Lift and travel	Check the main contactor wiring. If this does not solve the problem, please try to replace the main contactor or motor controller.
72	Motor Controller Over Voltage Fault	Lift and travel	Check the battery voltage and make sure the battery is not being charged before restarting the machine. If this does not solve the problem, please try to replace the motor controller.
73	Motor Controller Overheating Cutoff Fault	Lift and travel	Means that the motor may be overheating, please stop operations and let the machine cool down. If this does not solve the problem, please try restarting the machine. If this does not solve the problem, please try to replace the motor controller.
74	Motor Controller Over Heat Error	Lift and travel	Check the connections of the motor temperature sensor. If this does not solve the problem, please try to replace the motor controller.

Table 10-1 Machine Faults and Solutions (Sinoboom Control System) (continued)

Code	Description	Restricted functions	Recommended solution
75	Motor Controller Pump Motor Fault	Lift and travel	After checking to ensure that there are no problems with the pump motor wiring, restart the machine. If this does not solve the problem, please try to replace the motor controller.
76	Motor Controller Left Drive Motor Fault	Lift and travel	After checking to ensure that there are no problems with the motor wiring, restart the machine. If this does not solve the problem, please try to replace the motor controller.
77	Motor Controller Right Drive Motor Fault	Lift and travel	After checking to ensure that there are no problems with the motor wiring, restart the machine. If this does not solve the problem, please try to replace the motor controller.
78	Pump Motor Short Circuit Error	Lift and travel	After checking to ensure that there are no problems with the pump motor wiring, restart the machine. If this does not solve the problem, please try to replace the motor controller.
80	Over 80% Load Warning	Alarm only	This indicates that at the platform load has exceeded 80% and is approaching the maximum load capacity. Please try not to increase the load.
81	Driver Alarm	Lift and travel	Check the specific fault code of the driver alarm and determine the specific cause based on the fault code.
82	Left Brake Coil Fault	Lift and travel	Check whether the coil terminal wiring is correct. If this does not solve the problem, please check the coil itself for open or short circuit. If this does not solve the problem, please try to replace the motor controller.
83	Right Brake Coil Fault	Lift and travel	Check whether the coil terminal wiring is correct. If this does not solve the problem, please check the coil itself for open or short circuit. If this does not solve the problem, please try to replace the motor controller.
84	Motor Does Not Return Brake Release Signal	Lift and travel	Check whether the wiring between the controller and the motor is correct.
93	BMS System Fault	Lift and travel	Check the lithium battery fault code, and contact Sinoboom aftersales personnel.
CL	Collision Fault	Lift and travel	This alarm will be generated if the platform contacts an obstacle during lifting triggering the proximity switch. If the proximity switch is not triggered but still generates an alarm, please try replacing the proximity switch.
Ft	Foot Pedal Not Depressed Alarm	Limits all operations on the PCU	This alarm will occur when using the handle to operate the machine for travel and lifting movements without depressing the foot pedal. If the alarm still occurs if the foot pedal is depressed while operating the handle, please check whether there is a problem with the foot pedal switch.
LL	Machine Tilt Alarm	Lift and travel	Check whether the machine is tilted. If this alarm sounds when the machine is level, please check the level sensor and its wiring.

Table 10-1 Machine Faults and Solutions (Sinoboom Control System) (continued)

Code	Description	Restricted functions	Recommended solution
OL	Overloaded Platform Fault	All functions	This indicates that the platform load has exceeded the limit, please remove excess load immediately.
HE	Indoor and outdoor travel switch calibration error	Lift and travel	<p>Carry out checks in the following sequence:</p> <ul style="list-style-type: none"> • Check the installation position of the indoor and outdoor travel switches to ensure that the triggering position is within 0.6 m (1.97 ft) below the outdoor limit height; • Check whether the angle sensor is correctly installed; • Try carrying out height calibration again. <p>If the above methods still do not solve the problem, please try to replace the indoor and outdoor travel switches.</p>
PL	Overloaded Platform Warning	Lift and travel	This indicates that the platform load has exceeded the limit, please remove excess load immediately.
SL	Machine Sleep Mode	Lift and travel	Means that the machine has entered the sleep mode. Please operate the travel/lift switch button on the PCU to exit the sleep mode.

Table 10-2 Machine Faults and Solutions (DTC Control System)

Code	Description	Restricted functions	Recommended solution
02	System Communication Failure	All functions	Check the connection of the communication line for the upper and lower platforms. If this does not solve the problem, please try to replace the PCU or the ECU.
03	Invalid Option Setting Fault	All functions	Set appropriate options for this lift. If this does not solve the problem, please try to replace the ECU.
04	Calibration Fault	Alarm only	Re-calibrate, or check the angle and pressure sensor for error.
05	FAULT_PARAMETER_ERROR	All functions	Set appropriate parameters for this lift. If this does not solve the problem, please try to replace the ECU.
06	Hardware Version Fault	Lift and travel	Change ECU.
07	Openload Ad Fault	Lift and travel	Change ECU.
09	GPS Communication Fault	All functions	Check the communication line between the GPS and ECU. If the problem still exists, check the connection or replace the GPS module.
12	Chassis Up or Down Switch ON	Limits all operations on the ECU	Check whether the ECU Up button has been erroneously pushed or pressed. If this does not solve the problem, please try to replace the ECU.
13	Angle Sensor Communication Fau	Lift and travel	After checking to ensure that there are no problems with the angle sensor CAN communication wiring, restart the machine. If this does not solve the problem, please try to replace the angle sensor.

Table 10-2 Machine Faults and Solutions (DTC Control System) (continued)

Code	Description	Restricted functions	Recommended solution
17	BMS Relay Adhesion Fault	Lift limited, travel restricted to low speed	Replace the relay.
18	Pothole Guard Fault	Lift and travel	Carry out checks in the following sequence: <ul style="list-style-type: none"> • Check whether the pothole guard plate is deployed into its normal operating position; • Check whether the pothole guard plate limit switch and its wiring are in good operating condition; • Check whether the lower limit switch and its wiring are in good operating condition, and check whether the lower limit device is functioning normally.
19	BMS Voltage Sampling Fault	Lift limited, travel restricted to low speed	Inform the BMS factory to check battery voltage, or contact the Sinoboom aftersales staff.
20	BMS Communication Fault	All functions	Check the connection of the communication line between the ECU and BMS. If this does not solve the problem, please contact Sinoboom aftersales staff.
21	Lithium Battery Excessive Discharge Temperature Fault 1	Alarm only	Discharge Temperature Level-1 Fault: Inform the BMS factory to check battery temperature, or contact the Sinoboom aftersales staff.
22	Lithium Battery Discharge Current High Fault 1	Alarm only	Discharge Current High Fault 1: Inform the BMS factory to check battery current, or contact the Sinoboom aftersales staff.
23	Lithium Battery Total Voltage Low 1	Lift limited, travel restricted to low speed	Total Voltage Low Fault 1: Inform the BMS factory to check battery voltage, or contact the Sinoboom aftersales staff.
24	Lithium battery Cell Voltage Low Fault 1	Lift limited, travel restricted to low speed	Cell Voltage Low Fault 1: Inform the BMS factory to check battery voltage, or contact the Sinoboom aftersales staff.
25	Total Machine Voltage Low 2	Lift and travel	Cell Voltage Low Fault 2: Inform the BMS factory to check battery voltage, or contact the Sinoboom aftersales staff.
26	Large Difference in Voltage	Lift and travel	Inform the BMS factory to check battery voltage, or contact the Sinoboom aftersales staff.
27	Large Difference in Temperature	Lift and travel	Inform the BMS factory to check battery temperature, or contact the Sinoboom aftersales staff.
28	Discharge Current High 2	Lift and travel	Discharge Current High Fault 2: Inform the BMS factory to check battery current, or contact the Sinoboom aftersales staff.
29	Discharge Temperature High 2	Lift and travel	Discharge Temperature Fault 2: Inform the BMS factory to check battery temperature, or contact the Sinoboom aftersales staff.

Table 10-2 Machine Faults and Solutions (DTC Control System) (continued)

Code	Description	Restricted functions	Recommended solution
30	BMS Temperature Sampling Fault	Lift limited, travel restricted to low speed	Inform the BMS factory to check battery temperature, or contact the Sinoboom aftersales staff.
31	Pressure Sensor 1 Fault	All functions	Check whether the sensor and its wiring are in normal operating state. Check that the ECU sensor configuration options are correct. If this does not solve the problem, please try to replace the sensor.
32	Angle Sensor Fault	All functions	Check whether the sensor and its wiring are in normal operating state. Check that the ECU sensor configuration options are correct. If this does not solve the problem, please try to replace the sensor.
35	Pressure Sensor 2 Fault	All functions	Check whether the sensor and its wiring are in normal operating state. Check that the ECU sensor configuration options are correct. If this does not solve the problem, please try to replace the sensor.
36	Low battery level alarm	Travel restricted to low speed	Shows that battery charge is low, charge the battery immediately.
39	Level Sensor Fault	Lift and travel	After checking to ensure that there are no problems with the CAN communication wiring of level sensor, restart the machine. If this does not solve the problem, please try to replace the level sensor.
42	Left turn button of the handle was pressed when turning on the power.	Alarm only	Check whether the left turn button has been erroneously pushed or pressed. If this does not solve the problem, please try to replace the handle or PCU.
43	Right turn button of the handle was pressed when turning on the power.	Alarm only	Check whether the right turn button has been erroneously pushed or pressed. If this does not solve the problem, please try to replace the handle or PCU.
46	Platform Enable Switch ON at Power-up	Limits all operations on the PCU	Check whether any enable switches have been pressed or pushed-down erroneously. Check whether the zero parameter settings are correct. If this does not solve the problem, please try to replace the handle or PCU.
47	Joystick Not In Neutral at Power-up	All functions	Check whether the handle is in the zero position (vertical position). Check whether the zero position parameter settings are correct. If this does not solve the problem, please try to replace the handle or PCU.
52	Forward Solenoid Valve Fault (Hydraulic Drive)	Lift and travel	Check whether the wiring of the solenoid valve is correct. If this does not solve the problem, please check the coil valve for open or short circuit. If this still does not solve the problem, please try to replace the solenoid valve.
53	Reverse Solenoid Valve Fault (Hydraulic Drive)	Lift and travel	Check whether the wiring of the solenoid valve is correct. If this does not solve the problem, please check the coil valve for open or short circuit. If this still does not solve the problem, please try to replace the solenoid valve.

Table 10-2 Machine Faults and Solutions (DTC Control System) (continued)

Code	Description	Restricted functions	Recommended solution
54	Lift Up Coil Fault	Lift and travel	Check whether the wiring of the solenoid valve is correct. If this does not solve the problem, please check the coil valve for open or short circuit. If this still does not solve the problem, please try to replace the solenoid valve.
55	Lift Down Coil Fault	Lift and travel	Check whether the wiring of the solenoid valve is correct. If this does not solve the problem, please check the coil valve for open or short circuit. If this still does not solve the problem, please try to replace the solenoid valve.
56	Right Turn Coil Fault	Lift and travel	Check whether the wiring of the solenoid valve is correct. If this does not solve the problem, please check the coil valve for open or short circuit. If this still does not solve the problem, please try to replace the solenoid valve.
57	Left Turn Coil Fault	Lift and travel	Check whether the wiring of the solenoid valve is correct. If this does not solve the problem, please check the coil valve for open or short circuit. If this still does not solve the problem, please try to replace the solenoid valve.
58	General Brake Coil Fault	Lift and travel	Check whether the wiring of the solenoid valve is correct. If this does not solve the problem, please check the coil valve for open or short circuit. If this still does not solve the problem, please try to replace the solenoid valve.
60	Motor Controller Fault	Lift and travel	Check whether the wiring between the controller and the motor is correct. If this does not solve the problem, please check for other errors.
61	MC Current Sensor Fault	Alarm only	The travel or lift motor may be overheating. Cycle power after the machine cools down. If the problem can not be solved, check whether the wiring between the controller and the motor is correct. If the problem still exists, replace the motor controller.
62	MC Hardware Failsafe	Alarm only	Cycle power. If the problem still exists, check for the source of error or replace the motor controller.
64	MC SRO	Alarm only	Check if the “Enable Delay” parameter of motor controller is too short, and check other parameters of motor controller are set correctly.
67	MC HPD	Alarm only	Check if the “Enable Delay” parameter of motor controller is too short, and check other parameters of motor controller are set correctly.
68	Battery Low Voltage	All functions	Shows that battery voltage is low, charge the battery immediately. If the problem is not solved after fully charging the battery, please try to replace the battery.
69	MC High Neutral Current	Lift and travel	When the brake is active, the motor should stop rotating, and should have no current. However, if the MC receives a fault message that the brake is active while the motor is rotating, this fault will occur. This fault generally appears before other errors. If this error disappears after solving other errors, it can be

Table 10-2 Machine Faults and Solutions (DTC Control System) (continued)

Code	Description	Restricted functions	Recommended solution
			ignored. If this fault persists, please try replacing the motor or MC.
70	Steering Input Out of Range (Only Zapi)	Lift and travel	Means that the steering input voltage of the ZAPI motor controller is outside the specified range. Please change the relevant parameters of the ZAPI motor controller to solve the problem.
71	MC Main Contactor	Lift and travel	Check the main contactor wiring. If this does not solve the problem, please try to replace the main contactor or motor controller.
73	MC Thermal Cutback	Alarm only	Means that the motor may be overheating, please stop operations and let the machine cool down. If this does not solve the problem, please try restarting the machine. If the problem still exists, replace the motor controller.
74	MC Motor Overheat	Alarm only	Check the connections of the motor temperature sensor. If the problem still exists, replace the motor controller.
75	MC Pump Motor Fault	Alarm only	After checking to ensure that there are no problems with the pump motor wiring, restart the machine. If the problem still exists, replace the motor controller.
76	MC Left Motor Fault	Lift and travel	After checking to ensure that there are no problems with the motor wiring, restart the machine. If the problem still exists, replace the motor controller.
77	MC Right Motor Fault	Lift and travel	After checking to ensure that there are no problems with the motor wiring, restart the machine. If the problem still exists, replace the motor controller.
78	MC Pump Motor Short	Alarm only	After checking to ensure that there are no problems with the pump motor wiring, restart the machine. If the problem still exists, replace the motor controller.
79	MC Left Motor Short	Lift and travel	After checking to ensure that there are no problems with the motor wiring, restart the machine. If the problem still exists, replace the motor controller.
80	Over 80% Load Warning	Alarm only	This indicates that the platform load is approaching the maximum load capacity. Please try not to increase the load.
81	MC Right Motor Short	Lift and travel	After checking to ensure that there are no problems with the motor wiring, restart the machine. If the problem still exists, replace the motor controller.
82	Left Brake Coil Fault	Lift and travel	Check whether the coil terminal wiring is correct. If this does not solve the problem, please check the coil itself for open or short circuit. If the problem still exists, replace the motor controller.
83	Right Brake Coil Fault	Lift and travel	Check whether the coil terminal wiring is correct. If this does not solve the problem, please check the coil itself for open or short circuit. If the problem still exists, replace the motor controller.
84	Motor Post Shorted	Lift and travel	After checking to ensure that there are no problems with the motor wiring, restart the machine. If the problem still exists, replace the motor controller.

Table 10-2 Machine Faults and Solutions (DTC Control System) (continued)

Code	Description	Restricted functions	Recommended solution
88	MC Motor Fault	Lift and travel	Check the motor for correct wiring. If the problem still exists, replace the motor.
89	Motor Field Open	Lift and travel	Replace the motor.
90	Over 90% Load Warning	Alarm only	This indicates that the platform load is approaching the maximum load capacity. Please be prudent while increasing the load.
91	Left Motor Field Short	Lift and travel	Replace the motor.
92	Right Motor Field Short	Lift and travel	Replace the motor.
94	FAULT_DOWN_LIMIT	All functions	Check the down limit switch for wiring error. If this does not solve the problem, please try to replace the down limit switch.
99	Over 99% Load Warning	Alarm only	This indicates that the platform load is reaching the maximum load capacity. Please try not to increase the load.
OL	Overloaded Platform Fault	Lowering is only allowed while under the overload descent height	This indicates that the platform load has exceeded the limit, please remove excess load immediately.
OH	Platform Highest Position Warning	Lift	Lower the platform.
LL	Machine Tilt Alarm	Lift and travel	Check whether the machine is tilted. If this alarm sounds when the machine is level, please check the level sensor and its wiring.
Ft	Foot Pedal Not Depressed Alarm	Limits all operations on the PCU	This alarm will occur when using the handle to operate the machine for travel and lifting movements without depressing the foot pedal. If the alarm still occurs if the foot pedal is depressed while operating the handle, please check whether there is a problem with the foot pedal switch.
CL	Collision Fault	Lift and travel	This alarm will be generated if the platform contacts an obstacle during lifting triggering the proximity switch. If the proximity switch is not triggered but still generates an alarm, please try replacing the proximity switch.
EE	Enable Joystick First	All functions	This alarm occurs after the operator operates a function switch and then press the enable switch. Release the enable switch and the function switch, and then operate the machine as per the correct procedure.
LF	Lift Motion Error	All functions	Check whether the angle sensor is normal. If this does not solve the problem, please try to replace the angle sensor, or check the oil cylinder for leakage.

Charging Faults and Solutions

Fault code	Cause	Solution
E01 bAt	Output not connected to the battery or connected reversely, short circuit, damaged cell	Check whether the battery pack is connected correctly. Check whether the charger is properly connected. Inspect the individual cells in the battery pack for damage.
E02 AC	Abnormal utility supply (voltage)	Check whether the AC power cable from the AC outlet to the charger is connected properly. Make sure that the AC plug is firmly inserted into the AC outlet.
E03 Hot	Charger overtemperature cutoff	The charger's internal or ambient temperature is too high. The charger will shut down and enter the overheat protection mode. Place the charger in a well-ventilated site. Disconnect the charger and wait 15-20 min before starting a new charging process.
E04 bAt	High temperature protection for battery	When the battery temperature exceeds the preset value, the charger will shut down to prevent overheat. After the battery temperature drops, the charger will restart automatically.
E05 Err	Excessively high output current	Return the battery for repair.
E06 bAt	Excessively high battery voltage	Check and make sure the correct output battery voltage is connected.

10.2 BASIC TROUBLESHOOTING

Table 10-3

Fault	Cause	Solution
Machine has no power	Machine is not powered on.	<ul style="list-style-type: none"> The "ground/platform control selector switch" is in the neutral position. The emergency stop button at the platform controller or the ground controller is in the OFF position. The upper controller is malfunctioning. The lower controller is malfunctioning.
Machine communication fault	CAN equipment offline	<ul style="list-style-type: none"> Inspect whether the leads between the power supply and communication are inserted properly and reliably. Inspect whether all pins of the Deutsch plugs for the connecting cables between platform controller and ground controller are wired according to the drawing. Inspect whether the platform controller plug or the plug of the connecting cable between the platform controller and ground controller are in good contact. Inspect whether the platform controller is malfunctioning. Inspect whether the Deltatech plug of the ground controller is wired firmly and/or correctly.

Table 10-3 (continued)

Fault	Cause	Solution
Ground controller not functioning properly	The ground/platform control selector switch has not been turned to the ground controller	<ul style="list-style-type: none"> • The ground/platform control selector switch is not in the lower control position. • The system has not been powered off after the program has been downloaded to the ground controller. • Inspect the ground controller for malfunction.
Platform controller not functioning properly	The ground/platform control selector switch has not been turned to the platform controller	<ul style="list-style-type: none"> • The ground/platform control selector switch is not in the platform control position. • The system has not been powered off once after the program is downloaded to the platform controller. • Inspect whether the platform controller is malfunctioning.
Tilt alarm sounds even with the machine in level position	The level switch is not connected or defective.	<ul style="list-style-type: none"> • Inspect whether the level switch is inserted properly and firmly. • Inspect whether the level switch is malfunctioning.
The ground controller cannot control lowering when the machine has no load and is level	The lowering valve is faulty	<ul style="list-style-type: none"> • Inspect whether the digital input plug is inserted properly and firmly. • Inspect whether the wiring of the plug switch is malfunctioning. • Inspect whether the lead of the lowering valve is wrongly wired, and whether the lowering valve is malfunctioning.
The platform controller cannot control lowering – no alarm.	Staged lowering function	Reset the handle and perform lowering again.
The ground controller cannot control lifting with the platform level and unladen and at the lowest position.	Height calibration is wrong/the lift valve is malfunctioning.	<ul style="list-style-type: none"> • Inspect whether the digital input plug is inserted properly and firmly. • Inspect whether the wiring of the plug switch is malfunctioning. • Re-calibrate the height. • Inspect whether the lead of the lift valve is wrongly wired, and whether the lift valve is malfunctioning.
The platform cannot be lifted to the highest position indoors with the machine unladen	The height has not been calibrated/the travel switch is incorrectly set	<ul style="list-style-type: none"> • Re-calibrate the height. • Change the setting of the travel switch.
Platform stops rising further after reaching a certain position.	The travel switch setting is incorrect.	Recalibrate the travel switch.
Overload alarm when the machine is unloaded	The weight sensor has not been calibrated/this is the first lifting/lowering	Re-calibrate the load coefficient.

Table 10-3 (continued)

Fault	Cause	Solution
Forward function failed with no warning	Forward traveling function is malfunctioning.	<ul style="list-style-type: none"> • Check whether the PWM plug of the ground controller is inserted correctly and solidly. • Check whether the forward valve is correctly wired or working normally. • Inspect whether the ground controller is malfunctioning.
Reverse traveling function fails without warning	Reverse traveling function is malfunctioning.	<ul style="list-style-type: none"> • Check whether the PWM plug of the ground controller is inserted correctly and solidly. • Check whether the forward valve is correctly wired or working normally. • Inspect whether the ground controller is malfunctioning.
No warning after descending to the lowest position, high travel speed function fails	Lower limit switch not functioning properly/the hydraulic valve is malfunctioning	<ul style="list-style-type: none"> • Limit switch is incorrectly installed/malfunctioning • The high-speed hydraulic valve is connected incorrectly.
No overload warning	Weight sensor not calibrated for rated load or calibrated with wrong lift height.	<ul style="list-style-type: none"> • The sensor has not been calibrated. • The wiring of the load sensor is incorrect. • Faulty sensor
Machine travels and then stops intermittently.	Battery level low/incorrect calibration	<ul style="list-style-type: none"> • Re-calibrate parameters. • Battery is depleted, not as indicated by the battery gauge.
Parameters after setting could not be saved successfully after several attempts.	Saving error	<ul style="list-style-type: none"> • Parameters exceeding the limit. • The ground controller is malfunctioning.

11 FUNCTIONS AND CONTROLS

11.1 MACHINE POSITIONS

The machine positions/states covered in this manual are stowed position, transport position, operating position, and non-operating position. Each position is described in detail below:

- **Stowed position:** the scissor arms are fully retracted.
- **Transport position:** the scissor arms and the platform extension are fully retracted.
- **Operating position (elevated):** the scissor arms are elevated until disengaged from the down limit switch.
- **Non-operating position:** the scissor arms are not disengaged from the down limit switch.

Notes: when the scissor arms are disengaged from the down limit switch, the platform height (from the ground to the platform floor) shall be: 2.3 ± 0.3 m (7 ft 7 in \pm 12 in).

11.2 DRIVE FUNCTION

Driving at a speed that is appropriate for the given circumstances is essential for ensuring machine safety. The drive function should respond quickly and smoothly to the operator's control inputs. Travel operation should be normal, without vibration, impact, and abnormal noise across the full controllable speed range. To ensure proper functioning of the drive system and to check its condition, it is recommended to check the drive functions every 3 months or every 250 hours of operation.

Select a flat, level, unobstructed and solid surface to perform the following tests with the stowed platform carrying one person:

1. Mark two straight lines on the ground at a distance of 30 m (98.4 ft) from each other as the test start and stop lines.
2. Start the machine.
3. In the travel and steer mode, press and hold the enable button on the joystick and push the joystick forward to the full drive position.
4. Ensure the machine is traveling at high speed when the front wheels touch the test start line, start timing.
5. Keep the machine running at high speed. Stop the timer when the front wheel touches the test stop line.
6. Calculate the travel speed using the measured data, and compare it with the specified maximum travel speed in stowed position.

NOTICE

If the result exceeds the maximum stowed travel speed by 10 % or more, turn off and tag the machine, and contact a qualified service technician for inspection and repair.

11.3 BRAKE FUNCTION

Proper functioning of the brakes is essential for the safe operation of the machine. The brakes should respond to the operator's control inputs quickly and smoothly without any abnormal noise. To ensure proper brake functioning and to check their condition, it is recommended to check the brakes every 3 months or every 250 hours of operation.

Ensuring the machine's braking distance is within the normal range is an important indicator of the braking function being normal. Select a flat, level, unobstructed and solid surface to perform the following tests with the stowed platform carrying one person:

1. Verify that the machine's brakes have not been released.
2. Mark a test line on the ground as a reference.
3. Start the machine.
4. In the travel and steer mode, press and hold the enable button on the joystick and push the joystick forward to the full drive position.
5. Ensure the machine is traveling at high speed when the front wheels touch the test start line, then release the joystick quickly.
6. Measure the horizontal distance between the test line and the contact point between the front wheel and the ground, which is the braking distance.
7. Compare the measured distance with specified braking distance at full travel speed.

NOTICE

If the measured distance exceeds the specified maximum braking distance, immediately lower the platform to the stowed position, turn off and mark the machine, and contact a qualified service technician for inspection and repair.

11.4 POTHOLE PROTECTION DEVICE

Function of pothole protection device: when the platform rises to a certain height, the pothole protection device will extend to a vertical position and move close to the ground. When the machine is driven into a pothole the plate on the pothole protection device will support on the ground and prevent the machine from tipping over. It is recommended to check the pothole protection device every 3 months or after 250 hours of work.

Select a flat, level, unobstructed and solid surface to perform the following tests:

1. Start the machine.
2. When raising the platform from the stowed position to the operating position, the pothole protection devices on the left and right sides of the chassis should be fully extended to be perpendicular to the ground.
3. Forcefully push the pothole protection device from the outside inwards – it should not be flipped.
4. When the platform is lowered to the non-operating position, the pothole protection device will retract.
5. Place a 50 mm (2 in) high wooden block under the pothole protection device on the left side of the chassis.
6. Raise the platform to the operating position, the buzzer will sound, and the display will show the pothole protection fault code "18", the platform lift and traveling/steering functions will be disabled, and only platform lowering will be permitted.
7. Lower the platform to the stowed position and remove the wooden block from under the pothole protection device on the left side of the chassis.
8. Perform the same test from step 5 on the pothole protection device on the right side of the chassis.

NOTICE

If the pothole protection device is found to be not working properly during the test, immediately lower the platform to the stowed position, turn off and tag the machine, and contact a qualified service technician for inspection and repair.

11.5 TILT PROTECTION FUNCTION

The proper functioning of the tilt sensing system is essential for the safe operation of the machine. It is recommended to check the tilt sensing system every 3 months or after 250 hours of operation.

Select a flat, level, unobstructed and solid surface to perform the following tests:

1. Start the machine.
2. Drive the machine so the two wheels on the left (or right) side travel on a slope with an angle greater than 1.5°.
3. From the ground using the platform controller, lift the platform to operating position. Once the machine has reached the operating position, the buzzer sounds, the display shows the machine tilt fault code "LL", the lifting and driving functions are restricted, and the platform can only be lowered.
4. After lowering the platform to a non-operating position, drive the machine off the slope.
5. Drive the machine so that the two front (or rear) wheels are positioned on a slope with an angle greater than 3°.
6. From the ground using the platform controller, lift the platform to operating position. Once the machine has reached the operating position, the buzzer sounds, the display shows the machine tilt fault code "LL", the lifting and driving functions are restricted, and the platform can only be lowered.
7. After lowering the platform to a non-operating position, drive the machine off the slope.

NOTICE

If during the test it is found that the machine's movements are not restricted as expected, lower the platform to the stowed position, shut down the machine, tag it accordingly, and contact qualified maintenance technicians for inspection and repair.

11.6 OVERLOAD LIMIT FUNCTION

The rated load capacity of the platform is clearly specified in the **Machine Specifications** section of this manual. Machine operation should be restricted if the platform is overloaded.

The overload limit function is essential for the safe operation of the machine. Any malfunction may affect the stability of the machine. It is recommended to check the overload limit function every 3 months or after 250 hours of operation.

Select a flat, level, unobstructed and solid surface to perform the following tests with no load on the platform:

1. Start the machine.
2. Fully raise and lower the platform twice from the ground controller to ensure that the machine displays no obvious vibration or abnormalities, and is properly lubricated.
3. As long as the weight on the platform is less than or equal to the rated load capacity the platform can be lifted to its highest position.
4. After lifting the platform to the non-operating position, gradually apply load to the platform according to the rated load capacity of the platform. When the platform load weight is greater than 1.2 times of the rated platform load, the buzzer will sound, the display shows the platform overload fault code "OL", the lifting and travel functions will be restricted, but the platform is only allowed to lower. After the excess load is removed, all functions will be resumed.
5. After lifting the platform to the operating position, gradually apply load to the platform according to the rated load capacity of the platform. When the platform load weight is greater than 1.2 times of the rated platform load, the buzzer will sound, the display shows the platform overload fault code "OL", and all functions will be disabled. After the excess load is removed, all functions will be resumed.

NOTICE

If during the test it is found that the machine's movements are not restricted as expected, lower the platform to the stowed position, shut down the machine, tag it accordingly, and contact qualified maintenance technicians for inspection and repair.

NOTICE

Low temperature will increase the viscosity of hydraulic oil, and thicker oil will significantly impact the pressure detection. If the ambient temperature difference between the place of end customer and that of the machine manufacturer is $\geq 10^{\circ}\text{C}$ (50°F), or if the hydraulic oil temperature is lower than 15°C (59°F), the actual rated load will be smaller than the standard rated load and an alarm will be triggered (the "OL" symbol appears on the platform or the ground controller screens). Please re-calibrate the weighing sensor.

11.7 STAGED LOWERING FUNCTION

In order to reduce the risk of crushing and collision with obstacles while lowering the platform, the machine is equipped with a staged lowering function to be used while lowering the platform from the platform controls. It is recommended to check the staged lowering function every 3 months or after 250 hours of operation.

Select a flat, level, unobstructed and solid surface to perform the following tests:

1. Start the machine and raise the platform to the highest position.
2. Activate the platform lift mode from the ground using the platform controller, press and hold the enable button on the joystick and pull the joystick back. The platform will lower.
3. Once the platform is lowered to the non-operating position, the machine will stop lowering automatically.
4. Release the joystick to the neutral position.
5. Repeat step 2 to re-activate the platform lowering function, the platform will continue lowering 5 sec later.

NOTICE

If during testing it is found that the staged lowering function is not working, immediately lower the platform to the stowed position, turn off and mark the machine, and contact a qualified service technician for inspection and repair.

11.8 EMERGENCY LOWERING FUNCTION

When the power unit fails, the emergency lowering function can be used to lower the platform into place. It is recommended to check the emergency lowering function every 3 months or after 250 hours of operation.

Test the emergency lowering function as per the **Emergency Lowering** section in the Operation Manual.

NOTICE

If the emergency lowering function is found to not be working properly, immediately lower the platform to the stowed position, turn off and tag the machine, and contact a qualified service technician for inspection and repair.

This Page Intentionally Left Blank

12 CONTROL SYSTEM

DANGER

All operations in this section must be performed by authorized and qualified personnel who have undergone professional training by Sinoboom. Not meeting this requirement bears significant risk.

WARNING

Unsafe Operation Hazard



- The machine has been programmed before delivery. It's forbidden to modify the system settings and/or update the software without authorization from Sinoboom.

Due to different machine configurations, certain descriptions below may not apply to your machine. If questions arise during operation of the machine in accordance with the manual please hold the operation and contact Sinoboom after sales personnel in time.

- Not operating the machine properly may result in death, serious injury or machine damage.

NOTICE

PCU, ECU, sensors, etc. are precisely adjusted and have received protective treatment before delivery. Therefore, persons who have not been professionally trained and authorized by Sinoboom may not disassemble the respective housings, otherwise moisture and dust ingress may affect proper functioning of these devices.

12.1 SINOBOOM MAIN CONTROL SYSTEM (WIDE PANEL)

This section is applicable to machines configured with Sinoboom main control system and right chassis door with wide panel.

System Interface

Pull out the emergency stop button at the ground controller to the ON position and turn the key switch to ground control position. Press the Enter key on the main interface of the ground controller to enter the ECU menu selection mode. Select and enter different function interfaces by pressing the PgUp /PgDn keys. The system interface is described in the figure below:

Note: some interfaces can only be accessed with a password (the password can only be provided to personnel professionally trained and authorized by Sinoboom).



Fig. 1 System interface

ECU main interface(continued)

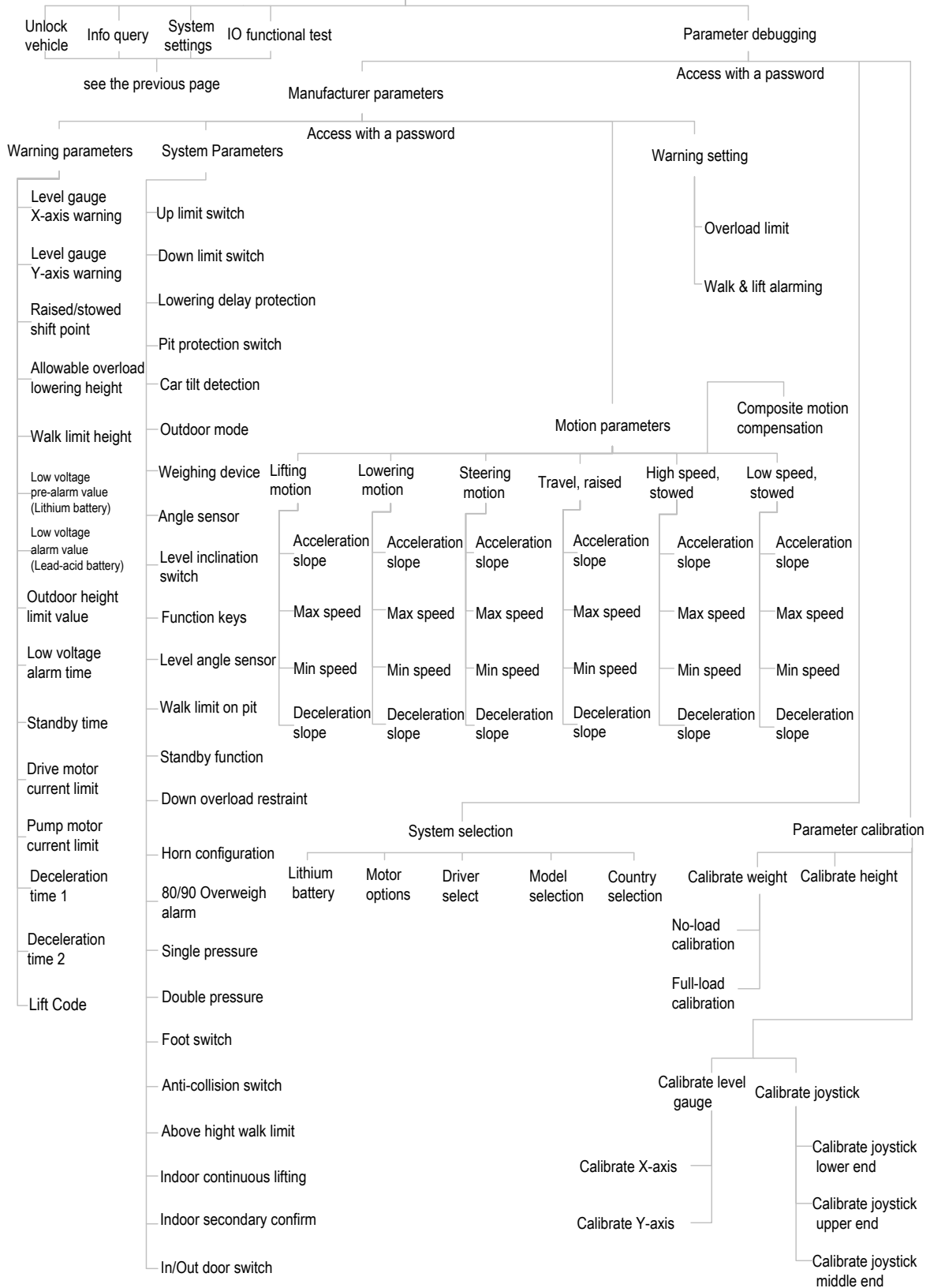


Fig. 2 System interface (continued)

Updating the Program

WARNING

Updating the program will restore the system parameters set by the original owner/user/Sinoboom to the original parameters set by the control system manufacturer. Updating the program without prior authorization from Sinoboom is strictly forbidden. Please contact SINOBOOM after-sales personnel if you wish to update the program.

1. Prepare a 4-32 GB USB flash drive in FAT32 file system format.
2. Upload the ECU program to the root directory of the USB flash drive: ECU_MAIN.bin.
Note: Please contact Sinoboom after-sales personnel if you wish to obtain the program.
3. Turn off the machine, and insert the USB flash drive into the program updating port (protected by a rubber plug) at the back of ECU.
4. Press and hold the Esc key on the ECU panel while powering on the machine. Release the Esc key 5 sec after power-on; the program will be updated automatically.
5. After the program is updated, power off the machine.

Checking the Program Version

After entering the ECU menu selection mode, select and the System Settings interface, then select System Version to identify the current program version.

Query Interface

In the Query Interface, users can query GPS information, PCU information, battery pack information, Curtis driver information and fault code information (for fault code causes and solutions please refer to **Fault Codes** section).

Brake Release

Only electric models are equipped with a brake release function.

1. Place the machine on solid level ground and secure the wheels with chocks to prevent the machine from moving inadvertently.

2. Make sure that the machine is in stowed without loose or unsecured objects, and there are no people or tools in the platform and no obstacles in the surrounding area.
3. Enter the ECU menu selection mode, then select and enter the “Brake Release” interface and press the Enter key for 5 sec.

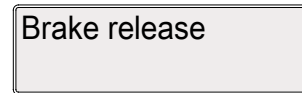


Fig. 3

4. The buzzer will sound, and the message “Brake Is Released” will be shown on the display, indicating that the brakes have been released successfully.

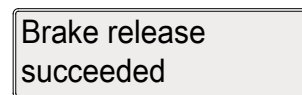


Fig. 4

5. The machine can now be towed or dragged by external force.
6. Return to the main interface through the Esc key, and power off the machine as needed. The setting will reset automatically after power-off and restart.

User Selection Setting

- Users can select the applicable country, driver and model of the machine in the User Selection menu of Parameter Debugging.
- The parameters (weight, height, level gauge and joystick) of the machine can be calibrated in the User Selection menu of Parameter Debugging.
- The lithium battery of the machine can be configured (if necessary) in the User Selection menu of Parameter Debugging.

Country Selection

1. After entering the ECU menu selection mode, select and enter the Country Selection interface, press PgUp key or PgDn key until the desired country is displayed, and press the Enter key for confirmation.
2. Select one country to open the corresponding configurations for the country. See the table below for the configurations for each country.

Item	China	Korea	Japan	EU	US & Australia	Abroad
Single/dual pressure sensor	OFF	Dual pressure	Dual pressure	Dual pressure	Dual pressure	Dual pressure

Outdoor mode	ON (depend on models)	ON	ON	ON	ON	ON
Weighing device	OFF	ON	ON	ON	ON	ON
Angle sensor	ON (depend on models)	ON	ON	ON	ON	ON
Overload descent limit	OFF	ON	ON	ON	ON	ON
Travel limit on pothole	OFF	ON	ON	OFF	OFF	OFF
Foot switch	OFF	ON	ON	OFF	OFF	OFF
80/90 overload alarm	OFF	OFF	OFF	OFF	OFF	OFF

Notes: The “Abroad” in Country Selection screen of Sinoboom control system refers to countries/regions except China, Korea, Japan, EU, US and Australia.

- Return to the main interface through the Esc key, and power off the machine as needed.

Joystick Calibration

NOTICE

The joystick calibration includes calibrating the joystick upper end, middle end and lower end. Please perform the calibration with the ECU panel within one cycle as per the following procedure.

- Enter the ECU menu selection mode.
- Calibrate joystick upper end:** push the joystick to the uppermost end and hold it, select and enter Calibrate Joystick Upper End (as shown in the figure below), then press and hold the enter key. Once “OK” is displayed in the lower right corner of the screen, the joystick upper end is successfully calibrated. Press the Esc key to return to the Joystick Calibration interface.

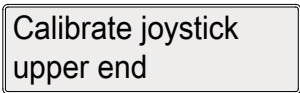


Fig. 5

- Calibrate joystick middle end:** push the joystick to the middle position and hold it, select and enter Calibrate Joystick Middle End (as shown in the figure below), then press and hold the enter key. Once “OK” is displayed in the lower right corner of the screen, the joystick middle end is successfully calibrated. Press the Esc key to return to the Joystick Calibration interface.

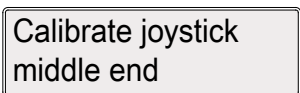


Fig. 6

- Calibrate joystick lower end:** push the joystick to the lowermost end and hold it, select and enter Calibrate Joystick Lower End (as shown in the figure below), then press and hold the enter key. Once “OK” is displayed in the lower right corner of the screen, the joystick lower end is successfully calibrated.

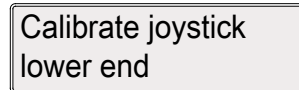


Fig. 7

- Return to the main interface through the Esc key, and power off the machine as needed.

Weight Calibration

NOTICE

- To ensure the accuracy of the weight calibration, a height calibration must be performed in advance.
- Weight calibration includes no-load and full-load calibration. Please complete the calibration using the ECU panel within one cycle as per the following procedures.

- No-load calibration**
 - Lower the platform to the stowed position. Make sure there is sufficient overhead space to allow the platform to be lifted to the maximum height safely.
 - Make sure that no heavy objects are placed on the platform.
 - Enter the ECU menu selection mode, then select and enter No-load Calibration interface, press the Enter key to start automatic calibration.

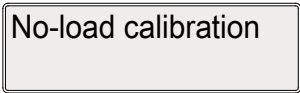


Fig. 8

4. The platform will raise and lower twice automatically: it will raise to the highest position and lower to the stowed position.
5. Once the screen displays “No-load Calibration Complete”, the no-load calibration was successful.

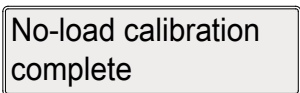


Fig. 9

6. Return to the Weight Calibration interface through the Esc key.
- **Full-load calibration**
 1. Place heavy objects on the platform that have the same weight as the rated load of the machine.
 2. Select and enter the Full-load calibration interface, then press the Enter key to start automatic calibration.

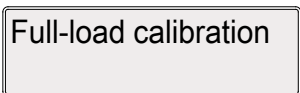


Fig. 10

3. The platform will raise and lower twice automatically: it will raise to the highest position and lower to the stowed position.
4. When the screen displays “Full-load calibration complete!”, the full-load calibration was successful.

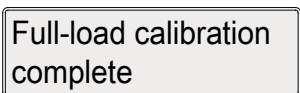


Fig. 11

5. Return to the main interface through the Esc key, and power off the machine as needed.

Height Calibration

1. Lower the platform to the stowed position. Make sure there is sufficient overhead space to allow the platform to be lifted to the maximum height safely.

2. Make sure that no heavy objects are placed on the platform.
3. Enter the ECU menu selection mode, then select and enter the Calibrate Height interface and press the Enter key.

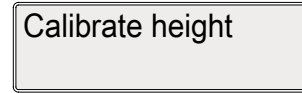


Fig. 12

4. The platform will automatically raise to the highest position, and then lower to the stowed position.
5. When the screen displays “Height Calibration Done”, the height calibration was successful.

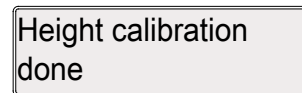


Fig. 13

6. Return to the main interface through the Esc key, lower the platform to the stowed position, and power off the machine as needed.

Parameters Setting

DANGER

Modifying the options in the parameter settings (including alarm parameters, functional configurations, speed parameters, and alarm settings, etc.) must be carried out only by authorized and qualified personnel who have undergone professional training by Sinoboom. Not meeting this requirement bears significant risks.

Warning Parameters

In the Warning Parameters menu of Parameter Debugging, the following parameters can be set: level gauge X-axis warning, level gauge Y-axis warning, raised/stowed shift point, allowable overload lowering height, low speed limit height, low voltage pre-alarm value, low voltage alarm value, outdoor height limit value, low voltage alarm time, standby time, drive motor current limit, pump motor current limit, deceleration time 1, deceleration time 2 and motor serial number.

Note:

- The input angle setting value needs to be multiplied by 10. For example, if the input value is 20, the actual angle value is 2°.
- The height setting value is in decimeter (dm).

- The input voltage setting value needs to be multiplied by 10. For example, if the input value is 20, the actual voltage value is 2 volts (V).
- The setting value of low voltage alarm time is in seconds (s); the setting value of the standby time is in minutes (min).

System Parameters

In the System Parameters menu of Parameter Debugging, the following can be set: up and down limit switches, pothole protection switch, lowering delay switch, car tilt detection, outdoor mode configuration, weighing device, angle sensor, level inclination switch, function keys, level angle sensor, pothole guard speed limit, standby function, dual pressure configuration, single pressure configuration, lowering overload limit, horn configuration, GPRS communication configuration, foot switch configuration, anti-collision switch configuration, 80/90 overweight alarm and vehicle tilt detection.

Motion Parameters

In the Motion Parameters menu of Parameter Debugging, the speed parameters of lifting motion, lowering motion, steering motion, raised travel speed, high speed (stowed) and low speed (stowed) can be set.

12.2 DTC-K500 MAIN CONTROL SYSTEM

This section is applicable to machines configured with DTC-K500 main control system.

System Interface

Pull out the emergency stop button to ON position and turn the key switch to Ground control position. Press the Enter key on the ECU panel while powering up the machine to enter the ECU menu selection mode. Select and enter different function interfaces through the PgUp key and PgDn key. The system interface is described in the figure below:

Note: some interfaces can only be accessed with a password (the password can only be provided to personnel professionally trained and authorized by Sinoboom).

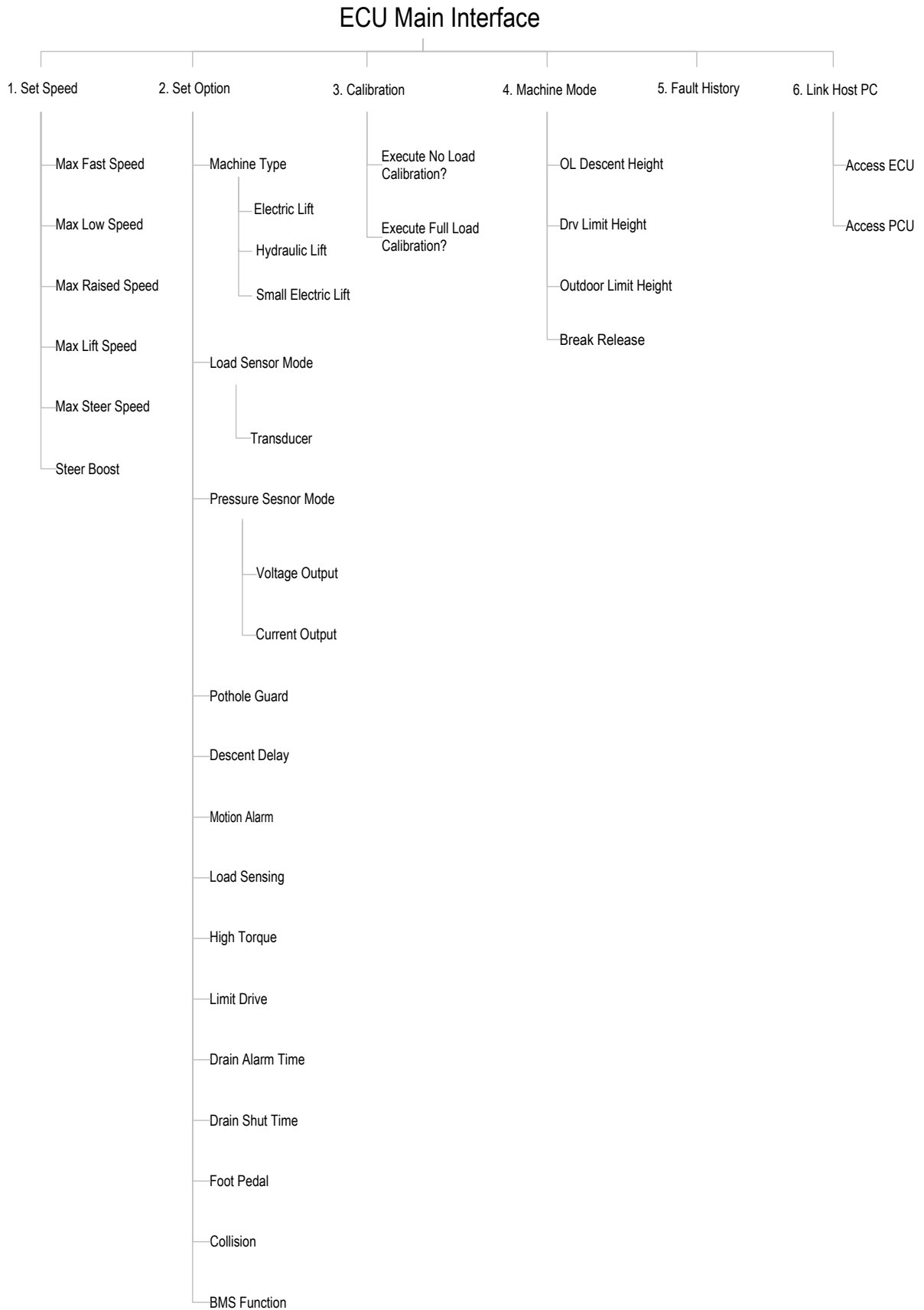


Fig. 14 System interface

Checking the Program Version

When the machine is powered on, the screen will display the current program version in the first 2s of startup.

Updating the Program

WARNING

Updating the program will restore the system parameters set by the original owner/user/Sinoboom to the original parameters set by the control system manufacturer. Updating the program without prior authorization from Sinoboom is strictly forbidden. Please contact SINOBOOM after-sales personnel to update the program.

Set Speed

In the “1.Set Speed” menu, the Max Fast Speed, Max Low Speed, Max Raised Speed, Max Lift Speed, Max Steer Speed and Steer Boost can be set.

Set Option

- In the “2.Set Option” menu, the Machine Type, Load Sensor Mode and Pressure Sensor Mode can be selected.
- In the “2.Set Option” menu, the Drain Alarm Time, Drain Shut Time can be set.
- In the “2.Set Option” menu, the Pothole Guard, Descent Delay, Motion Alarm, Load Sensing, High Torque, Limit Drive, Foot Pedal, Collision and BMS Function can be switched on or off. However, the Pothole Guard, Load Sensing and Motion Alarm functions are switched on by default. Even if these functions are turned off manually, they will return to the default ON state when the machine is powered on again.

Brake Release

Only electric models are equipped with a brake release function.

1. Place the machine on solid level ground and secure the wheels with chocks to prevent the machine from moving inadvertently.
2. Make sure that the machine is in stowed without loose or unsecured objects, and there are no people or tools in the platform and no obstacles in the surrounding area.

3. After entering the ECU menu selection mode, select and enter “Brake Release” interface, and press the Enter key for 5s.

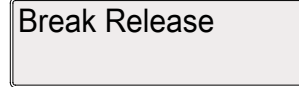


Fig. 15

4. When the screen displays “Brake is Released” and the horn sounds, the brake release is successfully done.

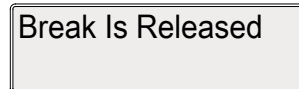


Fig. 16

5. Then the machine can be towed or dragged by external force.
6. Return to the main interface through the Esc key, and power off the machine as needed. The setting will reset automatically after power-off and restart.

Calibration Setting

Joystick Calibration

Ensure the joystick is in neutral position before power-on.

Weight and Height Calibration

NOTICE

- The height calibration will be carried out automatically while the weight calibration is performed.
- Weight calibration includes no-load calibration and full-load calibration. Please complete the calibration with the ECU panel within one cycle as per the following procedures.

No-load calibration (& height calibration)

1. Lower the platform to the stowed position, and ensure that the space above the platform allows the platform to be safely lifted to the maximum height.
2. Make sure no heavy objects are placed on the platform.
3. After entering the ECU menu selection mode, select and enter Calibration interface, and press the Enter key for confirmation.



Fig. 17

- When the screen displays “Execute No Load Calibration?”, press the Enter key for 5s to start automatic no-load calibration.

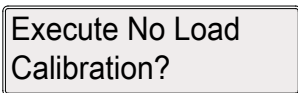


Fig. 18

- The platform will rise and descend for three times automatically: rise to the highest position and descend to the stowed position (the first, second and third ascending and descending movements are for height calibration, static calibration and dynamic calibration respectively).
- When the screen displays “No Load Calibration Complete!”, the no-load calibration (& height calibration) is successfully done.

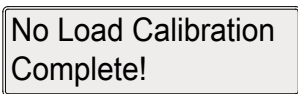


Fig. 19

- Return to the Calibration interface through the Esc key.

Full-load calibration

- Place heavy objects on the platform that have the same weight as the rated load of the machine.
- Select and enter Execute Full Load Calibration? interface, and press the Enter key for 5s to start automatic full-load calibration.

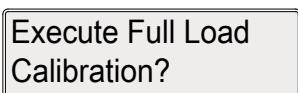


Fig. 20

- The platform will rise and descend for three times automatically: rise to the highest position and descend to the stowed position (the first, second and third ascending and descending movements are for height calibration, static calibration and dynamic calibration respectively).
- When the screen displays “Sensors Have Been Changed!”, the full-load calibration is successfully done.

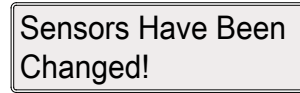


Fig. 21

- Return to the main interface through the Esc key, and power off the machine as needed.

Machine Mode Setting

Set OL Descent Height

- Ensure that the space above the platform allows the platform to be safely lifted to the maximum height and the machine is horizontally positioned.
- After entering the ECU menu selection mode, select and enter “OL Descent Height” interface.

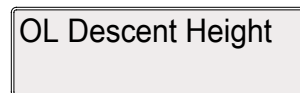


Fig. 22

- Raise the platform to a certain height (the desired OL descent height) with the ground controller.
- After pressing the Enter key for 5s, the system will return to the previous interface. Then the OL descent height is set successfully, and the current height is set as the OL descent height.
- Return to the main interface through the Esc key, lower the platform to the stowed position, and power off the machine as needed.

Set Drive Limit Height

- Ensure that the space above the platform allows the platform to be safely lifted to the maximum height and the machine is horizontally positioned.
- After entering the ECU menu selection mode, select and enter “Drv Limit Height” interface.

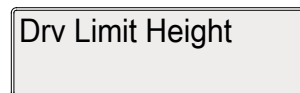


Fig. 23

- Raise the platform to a certain height (the desired drive limit height) with the ground controller.
- After pressing the Enter key for 5s, the system will return to the previous interface. Then the drive limit height is set successfully, and the current height is set as the drive limit height.

5. Return to the main interface through the Esc key, lower the platform to the stowed position, and power off the machine as needed.

Set Outdoor Limit Height

1. Ensure that the space above the platform allows the platform to be safely lifted to the maximum height and the machine is horizontally positioned.
2. After entering the ECU menu selection mode, select and enter "Outdoor Limit Height" interface.

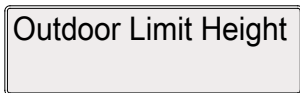


Fig. 24

3. Raise the platform to a certain height (the desired outdoor limit height) with the ground controller.
4. After pressing the Enter key for 5s, the system will return to the previous interface. Then the outdoor limit height is set successfully, and the current height is set as the outdoor limit height.
5. Return to the main interface through the Esc key, lower the platform to the stowed position, and power off the machine as needed.

Check Fault History

1. After entering the ECU menu selection mode, select and enter "5.Fault History" interface.

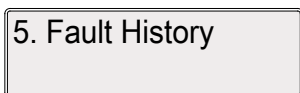


Fig. 25

2. Press the Enter key to view fault history (10 faults can be viewed. For the causes and solutions of fault codes, please refer to).
3. To clear fault history, press the Enter key for 5s in the interface displaying fault history, and the screen will display "Clear Fault History?". Then press the Enter key for 5s again to clear fault history. If not, skip this step and proceed to the next step.



Fig. 26

4. Return to the main interface through the Esc key, and power off the machine as needed.

This Page Intentionally Left Blank

Major Modification and Repair Record			
<p>Note:</p> <ol style="list-style-type: none"> 1. A major modification/repair is a modification/repair of the entire machine or its components that affects the stability, strength or performance of the machine. 2. A major modification/repair to the machine should be documented using the form below. This record should be retained until the machine is taken out of service or as required by the machine owner/company. 3. The machine must be inspected and verified after major modifications/repairs, with the inspection items including but not limited to all items in the Inspection and Preventative Maintenance Schedule. Once inspection and verification are complete the machine can be put back into service. 			

13.2 INSPECTION AND PREVENTIVE MAINTENANCE SCHEDULE

Inspection intervals are based on the use of the machine under normal operating conditions. The intervals should be shortened accordingly when operating in harsh environmental conditions.

Perform inspection and preventive maintenance for the items in the table below at the specified intervals. Maintenance and inspection intervals are calculated based on the months of service or the “accumulated operating hours” (cumulative working time) displayed on the ground controls (whichever comes first).

Table 13-1 Inspection and Preventive Maintenance Schedule

Item	Interval		
	Before each delivery ¹ or quarterly ²	Semiannually ³	Annually ⁴
Platform assembly			
Platform	1	1	1
Guardrails and floor	2	2	2
Access gate	1, 2, 3	1, 2, 3	1, 2, 3
Pedal for platform extension	1, 2, 3	1, 2, 3	1, 2, 3
Platform wear pads (at the connection with scissor arm) and fasteners	1, 2	1, 2	1, 2
Safety belt anchorage point	1, 2, 7	1, 2, 7	1, 2, 7
Scissor arms assembly			
Scissor arms	1, 2	1, 2	1, 2
Safety strut	1, 2, 3	1, 2, 3	1, 2, 3
Bearings	1, 2, 5, 12	1, 2, 5, 12	1, 2, 5, 8, 12
Pivot pins, retaining rings and fasteners	1, 2	1, 2	1, 2
Chassis assembly			
Chassis	2	2	2

Table 13-1 Inspection and Preventive Maintenance Schedule (continued)

Item	Interval		
	Before each delivery ¹ or quarterly ²	Semiannually ³	Annually ⁴
Chassis wear pads (at the connection with scissor arm)	1, 2, 5	1, 2, 5	1, 2, 5, 8
Tires	1, 2	1, 2	1, 2
Wheel nuts	150	150	150
Traveling and steering components	1, 2, 5	1, 2, 5	1, 2, 5
Bearings	1, 2, 5, 12	1, 2, 5, 12	1, 2, 5, 12
Chassis door at both sides	1, 2, 3	1, 2, 3	1, 2, 3
Ladder	1, 2, 5	1, 2, 5	1, 2, 5
Drive motor	1, 5, 6	1, 5, 6	1, 5, 6
Brake and brake release device	1, 5, 6	1, 5, 6	1, 5, 6
Lift motor	1, 2, 3, 6	1, 2, 3, 6, 13	1, 2, 3, 6, 13
Gear pump	1, 2, 3, 6	1, 2, 3, 6	1, 2, 3, 6
Hydraulic system			
Hydraulic pump	1, 2, 3, 6	1, 2, 3, 6	1, 2, 3, 6
Hydraulic cylinder	1, 2, 3, 5, 6, 12	1, 2, 3, 5, 6, 12	1, 2, 3, 5, 6, 12
Hydraulic valves	1, 2, 3, 5, 6	1, 2, 3, 5, 6	1, 2, 3, 5, 6
Hydraulic hoses, pipes and fitting	1, 2, 6	1, 2, 6	1, 2, 6
Hydraulic tank	1, 2, 3, 5, 6	1, 2, 3, 5, 6	1, 2, 3, 5, 6
Hydraulic tank air filter	1, 5, 6	1, 5, 6, 11	1, 5, 6, 11
Hydraulic oil filter	1, 5, 6	1, 5, 6	1, 5, 6, 11
Hydraulic oil	5, 6	5, 6	5, 6, 11
Electrical system			
Electrical harness, connectors	1, 2	1, 2	1, 2
Battery	1, 2, 6, 9, 12	1, 2, 6, 9, 12	1, 2, 6, 9, 12
Electrolyte	6	6	6
Charging function	3	3	3
Instruments, gauges, switches, lamps, horn	1, 3	1, 3	1, 3
Functions and controls			
Platform controller	1, 3, 4, 7, 10	1, 3, 4, 7, 10	1, 3, 4, 7, 10
Ground controller	1, 3, 4, 7, 10	1, 3, 4, 7, 10	1, 3, 4, 7, 10
Function control lock, secondary guarding device and brake	1, 3, 10	1, 3, 10	1, 3, 10
Emergency stop button (ground and platform)	1, 3, 10	1, 3, 10	1, 3, 10

Table 13-1 Inspection and Preventive Maintenance Schedule (continued)

Item	Interval		
	Before each delivery ¹ or quarterly ²	Semiannually ³	Annually ⁴
Limit switches and power switch	1, 3, 10	1, 3, 10	1, 3, 10
Overload limit function	1, 3, 10	1, 3, 10	1, 3, 10
Tilt alarm	1, 3, 10	1, 3, 10	1, 3, 10
Pothole protection device	1, 3, 10	1, 3, 10	1, 3, 10
Emergency lowering device	1, 3, 10	1, 3, 10	1, 3, 10
Drive function	1, 3, 10	1, 3, 10	1, 3, 10
Brake function	1, 3, 10	1, 3, 10	1, 3, 10
Other			
Operation Manual in the manuals compartment	10	10	10
All decals/labels complete, clear and secure	10	10	10
Annual inspection date of the machine	/	/	10
No unapproved changes or additions	10	10	10
All safety publications taken into account	10	10	10
General structural components and weldments	2	2	2
All fasteners, pins, protective guards and covers	1, 2	1, 2	1, 2
Greasing and lubricating according to specifications	10	10	10
Functional test of all systems	10	10	10
Paint and appearance	5	5	5
Inspection date stamped on the chassis	/	/	10
Notify Sinoboom of machine ownership (change)	/	/	10

Table 13-1 Inspection and Preventive Maintenance Schedule (continued)

Item	Interval		
	Before each delivery ¹ or quarterly ²	Semiannually ³	Annually ⁴
<p>Note:</p> <p>¹ Before each sale, lease or shipment delivery;</p> <p>² In service for 3 months or 250 hours; or out of service for more than 3 months;</p> <p>³ In service for 6 months or 500 hours;</p> <p>⁴ Once a year and no later than 13 months from the date of the previous annual machine inspection;</p> <p>⁵⁰ The first inspection shall be performed once the machine reaches 50 hours in service for the first time. This occurs only once in the service life of the machine.</p> <p>²⁵⁰ The first inspection shall be performed once the machine reaches 250 hours in service for the first time. This occurs only once in the service life of the machine.</p> <p>NO.1 Before the machine is put into service for the first time</p>			
<p>Inspection activity (numerical codes):</p> <ol style="list-style-type: none"> 1. Check for correct installation (accurate position, firmly installed, tightened to the specified torque) 2. Visual inspection for damage (cracks, cracked welds, deformation, wear, corrosion, excessive wear, gouges, abrasions and exposed threads) 3. Check for normal function 4. Check for normal return to neutral or "off" position (self-resetting switches return to neutral or "off" position after released) 5. Clean and free of foreign objects 6. Check for correct level, sealing and leaks 7. Labels complete, clear and secure 8. Check for appropriate dimensions/tolerances 9. Fully charged 10. Verify/perform 11. Replace the oil or filter element 12. Correctly lubricated 13. Inspect the carbon brush 			

This Page Intentionally Left Blank

Always for Better Access Solutions



Hunan Sinoboom Intelligent Equipment Co., Ltd.

No.128, East Jinzhou Avenue, Ningxiang High-tech Industrial Park, Changsha, Hunan, China

☎ 0086-0731-87116222 (Sales) & 0086-0731-87116333 (Service)

✉ sales@sinoboom.com

🏠 www.sinoboom.com

North American Subsidiary

Sinoboom North American LLC

310 Mason Creek Drive
unit #100

Katy, TX 77450, US

Tel: (281) 729-5425

E-mail: info@sinoboom.us

Europe Subsidiary

Sinoboom B.V.

Nikkelstraat 26, NL-2984 AM Ridderkerk,
The Netherlands

Tel: +31 180 225 666

E-mail: info@sinoboom.eu

Korea Subsidiary

Sinoboom Korea Co., Ltd.

95, Docheong-ro, Yeongtong-gu, Suwon-si,
Gyeonggi-do, Republic of Korea

Tel: 010-8310-8026

E-mail: ka1@sinoboom.com

Australia Subsidiary

Sinoboom Intelligent Equipment Pty Ltd.

50/358 Clarendon St, South Melbourne VIC
3205, Australia

E-mail: au@sinoboom.com

Singapore Subsidiary

Star Access Solutions Pte. Ltd.

112 Robinson Road #03-01 Robinson 112
Singapore 068902

Poland Subsidiary

Sinoboom Poland sp. z o.o.

Ul. Bolesława Krzywoustego 74A
61-144 Poznań, Poland