

USE AND MAINTENANCE
USO E MANUTENZIONE
UTILISATION ET ENTRETIEN
BETRIEB UND WARTUNG
USOY MANTENIMIENTO

NEF_{SERIES}

G-DRIVE ENGINES

Publication edited by:
FPT Industrial S.p.A.
Via Puglia 15, 10156 Torino, Italia
www.fptindustrial.com
Print L31900265 - 04.15



HIMOINSA | HRFW-200 | 191004787

NEF SERIES

NEF45 SM1F

NEF45 TE1F/TE2F

NEF67 TM1F

NEF67 TE1F/TE2F/TE3F

USE AND MAINTENANCE

INTRODUCTION

We would like to thank you for buying an FPT product, and compliment you on your choice of engine.

Before you carry out any operation involving the engine or its fittings, please read the contents of this manual carefully; compliance with the instructions provided in the manual is the best way to guarantee trouble-free, long term operation of the engine.

The contents of this manual refer to the standard configuration of the engine, and the illustrations are purely indicative. Some instructions are provided by giving the sequence of operations to be carried out in order to allow the engine and/or its fittings to perform in a certain way. In some cases they will be dependent on the configuration of the commands and the set-up of the machine on which the engine is installed; for any points that differ from the contents of this manual, please consult the instructions provided by the machine Manufacturer or a specific manual.

The information provided below was current at the date of publication.

The Manufacturer reserves the right to make modifications at any time without prior notice, for technical or commercial reasons or to update the engines to comply with legal requirements in the various Countries.

The Manufacturer declines all liability for any errors or omissions.

Please remember that the FPT Technical Service Network is available to offer you its experience and professional skills, wherever you may be.

TABLE OF CONTENTS

Page

■ GENERAL INFORMATION	3
Guarantee	3
Spare parts	3
Liability	3
Safety	3
Safety warning symbols	4
Engine technical data NEF45 SM1F	5
Engine technical data NEF45 TE1F/TE2F	8
Engine technical data NEF67 TM1F	11
Engine technical data NEF67 TE1F/TE2F/TE3F	14
Signs	17
■ USE	18
Preliminary checks	18
Starting and stopping the engine	18
Engine pre-heating (optional)	18
For proper use of the engine	19
Special warnings	19
Running in	21
Refilling	21
■ CONTROLS AND MAINTENANCE	24
Maintenance personnel	24
Accident prevention	24
Frequency	25
Requirements	28
Checks to be made during periods of use - how to proceed ..	28
Planned maintenance - how to proceed	34
Unscheduled maintenance - how to proceed	43
Moving the engine	45
Disposal of waste	45
■ BEHAVIOUR IN AN EMERGENCY	46

■ GENERAL INFORMATION

GUARANTEE

In order to ensure that your engine gives the best possible performance and to take advantage of the FPT guarantee, you must follow the indications provided in this publication with great care; failure to do so may result in invalidation of the guarantee.

SPARE PARTS

Always use Original FPT Spare parts. This is essential to keep the engine in original running order.

The use of non-original spare parts will not only invalidate the guarantee, but will mean that FPT will not be considered liable in any way during the whole working life of the engine.

LIABILITY

The Manufacturer's responsibility is subordinate to the performance of the check and maintenance operations specified and described in this manual; their performance must be demonstrated for this purpose. Any necessary unscheduled maintenance operations must be carried out by qualified FPT Network Workshop personnel, using the specifically provided instruments and equipment.

SAFETY

The following information is intended to encourage caution when using the engine, so as to avoid damage to persons or property as a result of improper or incorrect behaviour.

- ❑ The engines must only be used for the purposes indicated by the Manufacturer.
- ❑ Any tampering, modification and use of non-original spare parts may compromise proper operation and safe use of the engine; **never, under any circumstances** make modifications to the wiring and to the units equipping the engine, or connect them to other power systems.
- ❑ Pay particular attention to moving parts of the engine, to high temperature components and to circuits containing pressurised fluids; its electrical equipment houses electrical currents and voltage.
- ❑ The exhaust fumes produced by the engine are bad for your health.
- ❑ The engine must be handled using suitable lifting tackle, making use of the U-bolts provided on the engine for that purpose.
- ❑ The engine must not be started up and used until the machine in which it installed has satisfied all necessary safety requirements, or until the machine has been guaranteed to comply with local laws and regulations.
- ❑ The operations required to guarantee the best possible use and preservation of the engine must only be carried out by persons of proven experience, equipment with tools considered suitable by FPT .

For the purpose of safety, further recommendations are given in the CONTROLS AND MAINTENANCE chapter.

SAFETY WARNING SYMBOLS

You will find these symbols on the following pages; follow the instructions to which they refer, for your own safety and that of your engine.



Risk of injury: failure to comply with these instructions can result in the risk of serious injury.



Risk of serious damage to the engine: the partial or total non-observance of these instructions could cause serious damage to the engine and may nullify the warranty.



General risk: combines the risks of both the signs described above.



Safeguarding the environment: indicates the correct behaviour so that vehicle use is as environmentally friendly as possible.

ENGINE TECHNICAL DATA NEF45 SM1F

The technical code and serial number are indicated on a plate, which is located on different parts of the engine, according to the model: flywheel casing, tappet cover, other.

Code	NEF45 SM1F
Engine family	F4
Cycle	4-stroke diesel
Number and arrangement of cylinders	4, in line
Bore x stroke	104 x 132 mm
Total displacement	4,500 cm ³
Air system	Turbocharged without intercooler
Injection type	Direct injection
Engine direction of rotation	Anticlockwise (seen from flywheel side)
Speed regulator	Mechanical
Dry weight	~450 kg (G-Drive)

Electrical system	12 V
Accumulator/s	
- capacity	100 Ah or above
- discharge current	650 A or above

Performance (*)	NEF45 SM1F	
STAGE IIIA	Prime	54.5 kWm @ 1500 rpm
	Stand-by	60 kWm @ 1500 rpm

(*) Net power to the flywheel in compliance with ISO 3046-1. Test conditions: T 25 °C; atmospheric pressure 100 kPa; relative humidity 30%.



It is severely prohibited, under penalty of cancellation of the warranty and of the responsibilities of FPT, to change the characteristics indicated above.

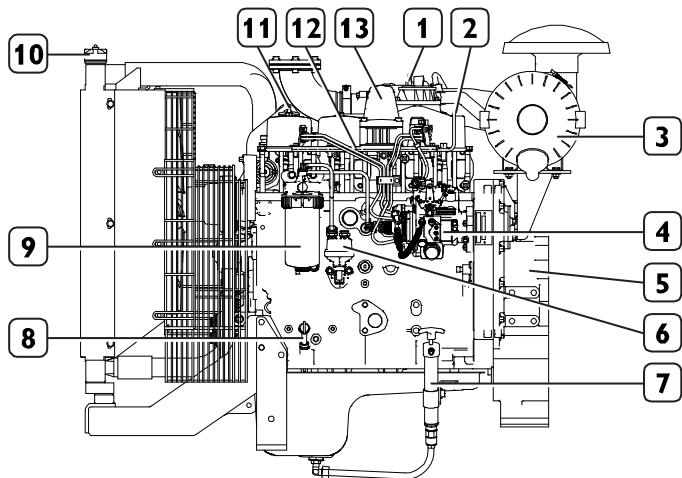

14_192_N

NEF45 SM1F

1. Oil vapour filter - 2. Lifting eyelet - 3. Air filter - 4. Injection pump - 5. Flywheel casing - 6. Priming pump - 7. Oil extraction pump - 8. Oil level dipstick - 9. Fuel filter - 10. Coolant inlet plug - 11. Oil filling cap - 12. High pressure pipes - 13. Turbocharger air inlet

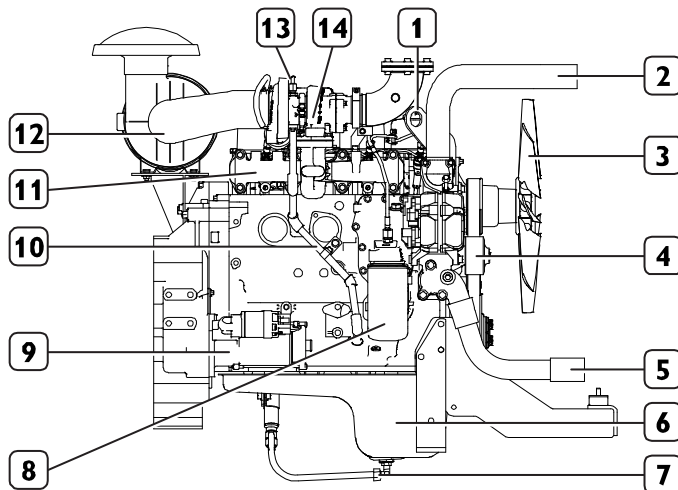

14_191_N

NEF45 SM1F

1. Lifting eyelet - 2. Coolant outlet pipe - 3. Fan - 4. Water pump - 5. Coolant intake pipe - 6. Oil sump - 7. Oil extraction pump - 8. Oil filter - 9. Starter motor - 10. Lubricating oil return from turbocharger pipe - 11. Exhaust manifold - 12. Air filter - 13. Oil delivery to turbocharger contact - 14. Turbocharger

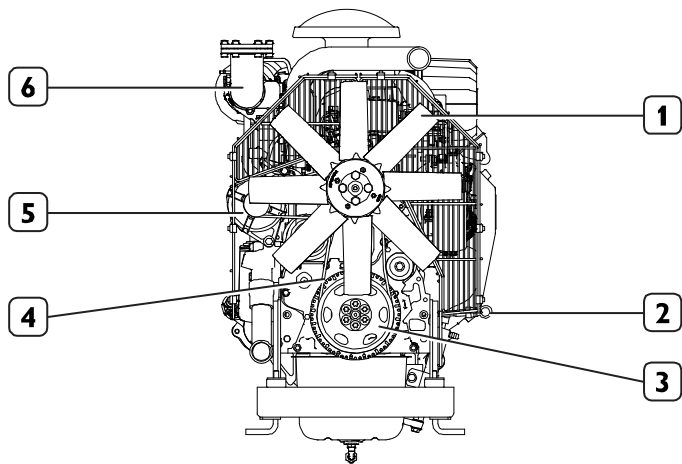

14_193_N

NEF45 SM1F

1. Fan - 2. Oil level dipstick - 3. Crankshaft pulley - 4. Poly-V belt - 5. Alternator - 6. Exhaust gas pipe

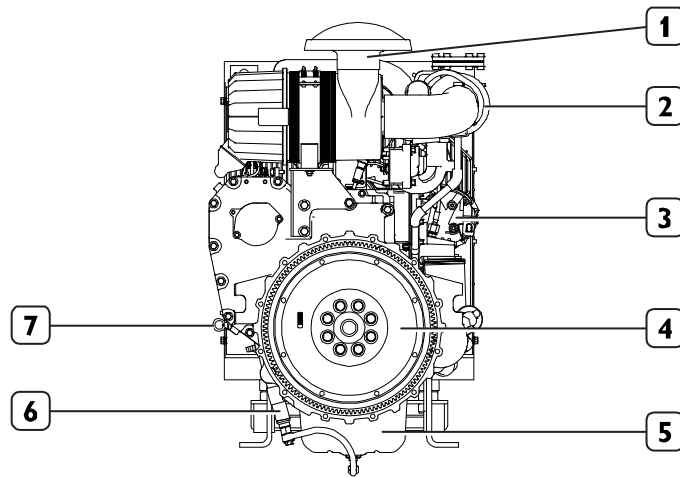

14_194_N

NEF45 SM1F

1. Air filter - 2. Turbocharger - 3. Alternator - 4. Engine flywheel - 5. Oil pump - 6. Oil evacuation pump - 7. Oil level dipstick

ENGINE TECHNICAL DATA NEF45 TE1F/TE2F

The technical code and serial number are indicated on a plate, which is located on different parts of the engine, according to the model: flywheel casing, tappet cover, other.

Code	NEF45 TE1F/TE2F
Engine family	F4
Cycle	4-stroke diesel
Number and arrangement of cylinders	4, in line
Bore x stroke	104 x 132 mm
Total displacement	4,500 cm ³
Air system	Turbocharged with intercooler
Injection type	Direct injection
Engine direction of rotation	Anticlockwise (seen from flywheel side)
Speed regulator	Electronically managed
Dry weight	~500 kg (G-Drive)

Electrical system 12 V

Accumulator/s	
- capacity	100 Ah or above
- discharge current	650 A or above

Performance (*)		NEF45 TE1F
STAGE IIIA	Prime	72.5 kWm @ 1500 rpm
	Stand-by	80 kWm @ 1500 rpm

Performance (*)		NEF45 TE2F
STAGE IIIA	Prime	89 kWm @ 1500 rpm
	Stand-by	98 kWm @ 1500 rpm

(*) Net power to the flywheel in compliance with ISO 3046-1. Test conditions: T 25 °C; atmospheric pressure 100 kPa; relative humidity 30%.



It is severely prohibited, under penalty of cancellation of the warranty and of the responsibilities of FPT, to change the characteristics indicated above.

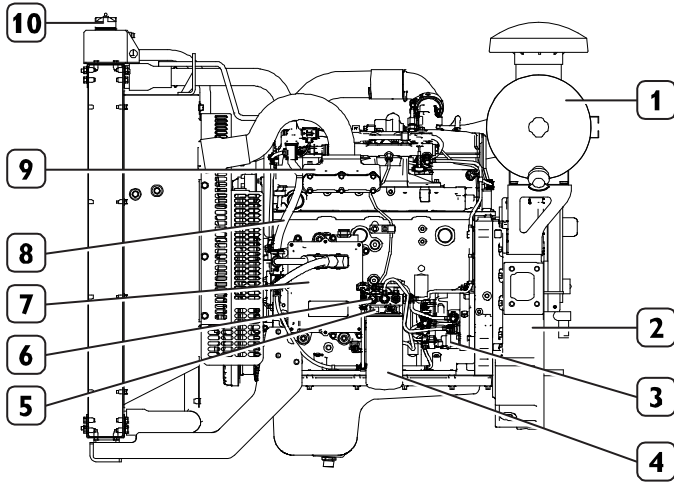

14 196 N

NEF45 TE1F/TE2F

1. Air filter - 2. Flywheel casing - 3. High-pressure pump - 4. Fuel filter - 5. Fuel preheating element - 6. Fuel temperature sensor - 7. EDC electronic control unit - 8. Engine cable - 9. Intake manifold - 10. Coolant inlet plug

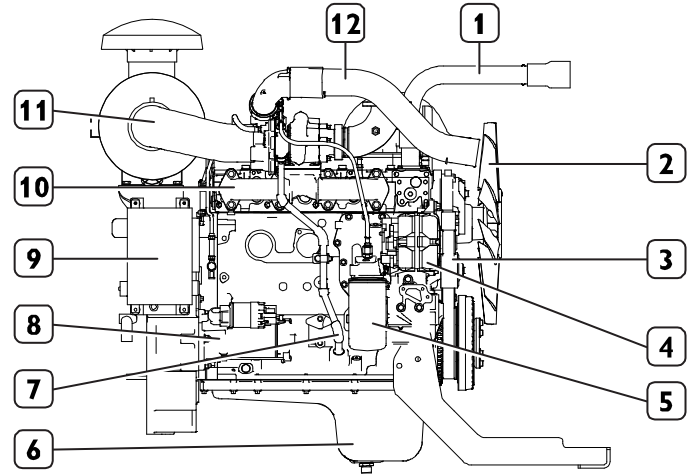

14 195 N

NEF45 TE1F/TE2F

1. Coolant outlet pipe - 2. Fan - 3. Water pump - 4. Alternator - 5. Oil filter - 6. Oil pump - 7. Lubricating oil return from turbocharger pipe - 8. Starter motor - 9. Completion kit - 10. Exhaust manifold - 11. Air filter - 12. Exhaust gas pipe

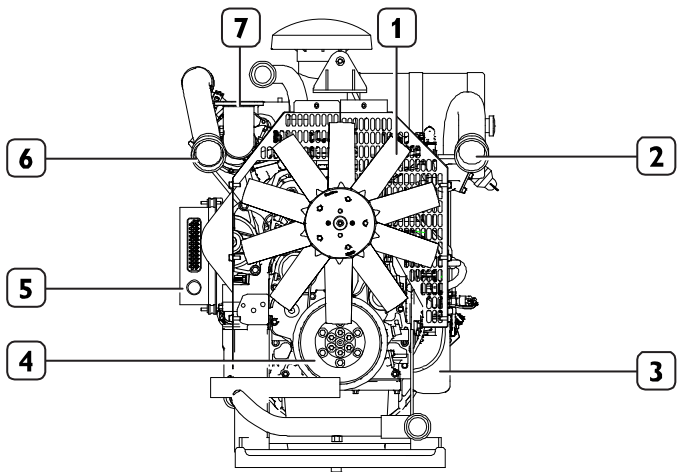

14_197_N

NEF45 TE1F/TE2F

1. Fan - 2. Air from radiator intake pipe - 3. Fuel filter - 4. Crankshaft pulley - 5. Completion kit - 6. Air inlet to compressor pipe - 7. Exhaust gas pipe

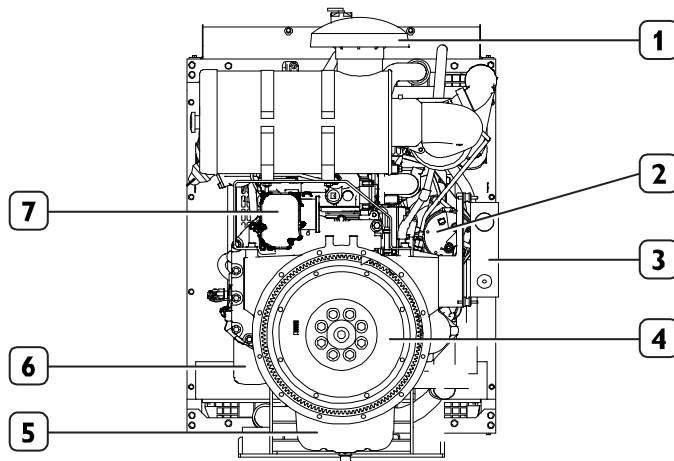

14_198_N

NEF45 TE1F/TE2F

1. Air filter - 2. Alternator - 3. Completion kit - 4. Engine flywheel - 5. Oil sump - 6. Fuel filter - 7. Oil vapour filter housing

ENGINE TECHNICAL DATA NEF67 TM1F

The technical code and serial number are indicated on a plate, which is located on different parts of the engine, according to the model: flywheel casing, tappet cover, other.

Code	NEF67 TM1F
Engine family	F4
Cycle	4-stroke diesel
Number and arrangement of cylinders	6, in line
Bore x stroke	104 x 132 mm
Total displacement	6,728 cm ³
Air system	Turbocharged with intercooler
Injection type	Direct injection
Engine direction of rotation	Anticlockwise (seen from flywheel side)
Speed regulator	Mechanical
Dry weight	~640 (G-Drive)

Electrical system	12 V
Accumulator/s	
- capacity	180 Ah
- discharge current	800 A

Performance (*)	NEF67 TM1F	
STAGE IIIA	Prime	113.5 kWm @ 1500 rpm
	Stand-by	125 kWm @ 1500 rpm

(*) Net power at the flywheel in accordance with the standard ISO 8528. Test conditions: T 25 °C; atmospheric pressure 100 kPa; relative humidity 30%.



It is severely prohibited, under penalty of cancellation of the warranty and of the responsibilities of FPT, to change the characteristics indicated above.

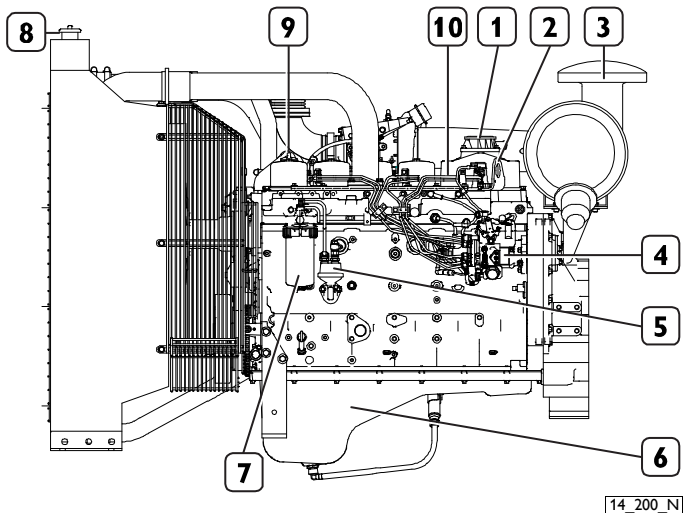

NEF67 TM1F

- 1. Oil vapour filter - 2. Lifting eyelet - 3. Air filter - 4. Injection pump -
- 5. Priming pump- 6. Oil sump - 7. Fuel filter - 8. Coolant inlet plug -
- 9. Oil filling cap - 10. High-pressure pipes

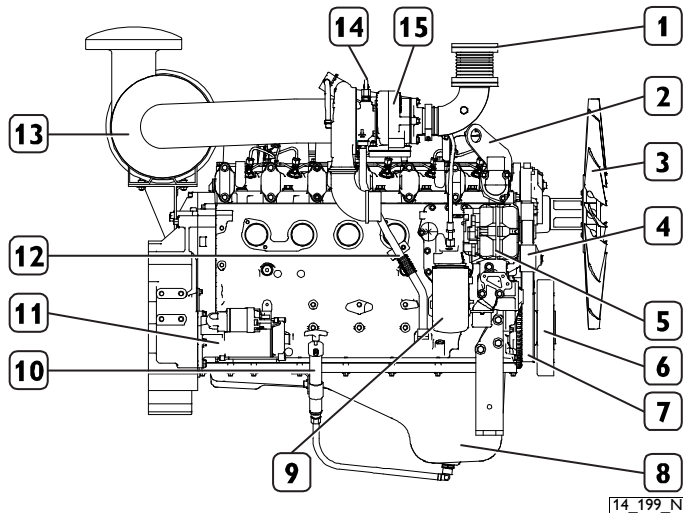

NEF67 TM1F

- 1. Exhaust gas pipe - 2. Lifting eyelet - 3. Fan - 4. Water pump -
- 5. Alternator - 6. Crankshaft pulley - 7. Poly-V belt - 8. Oil sump -
- 9. Oil filter - 10. Oil evacuation pump - 11. Electric starter motor -
- 12. Lubricating oil return from turbocharger pipe - 13. Air filter -
- 14. Lubricating oil supply to turbocharger pipe - 15. Turbocharger

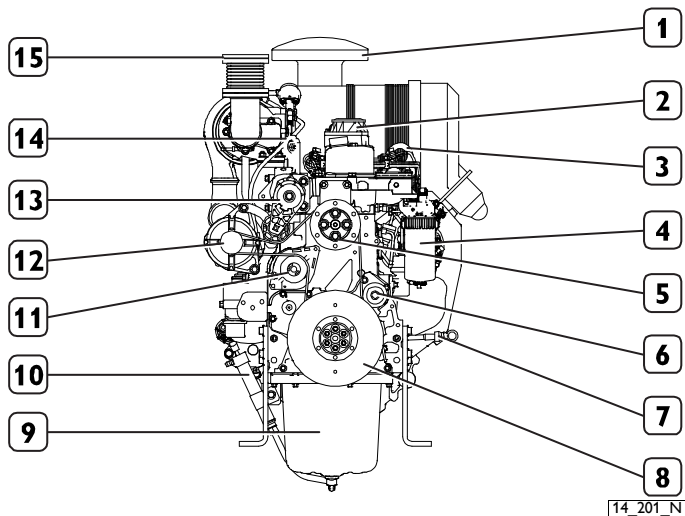

14_201_N

NEF67 TM1F

1. Air filter - 2. Oil vapour filter - 3. Lifting eyelet - 4. Fuel filter - 5. Fan pulley - 6. Guide pulley belt tensioner - 7. Oil level dipstick - 8. Crankshaft pulley - 9. Oil sump - 10. Oil evacuation pump - 11. Water pump - 12. Alternator - 13. Automatic belt tensioner - 14. Lifting eyelet - 15. Exhaust gas pipe

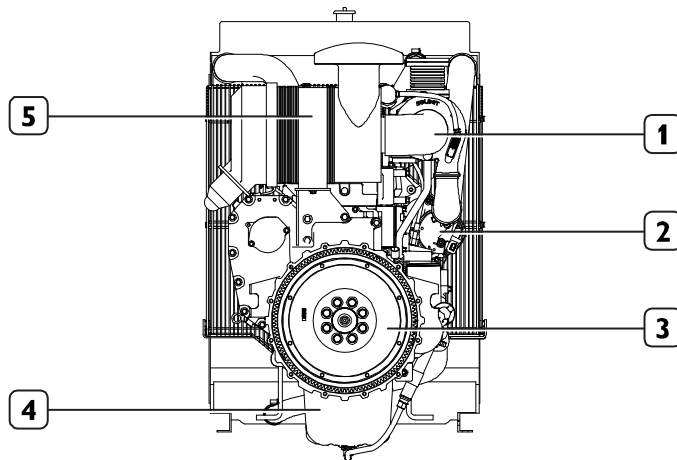

14_202_N

NEF67 TM1F

1. Turbocharger - 2. Alternator - 3. Engine flywheel - 4. Oil sump - 5. Air filter

ENGINE TECHNICAL DATA

NEF67 TE1F/TE2F/TE3F

The technical code and serial number are indicated on a plate, which is located on different parts of the engine, according to the model: flywheel casing, tappet cover, other.

Code	NEF67 TE1F/TE2F/TE3F
Engine family	F4
Cycle	4-stroke diesel
Number and arrangement of cylinders	6, in line
Bore x stroke	104 x 132 mm
Total displacement	6,728 cm ³
Air system	Turbocharged with intercooler
Injection type	Common Rail, electronically managed
Engine direction of rotation	Anticlockwise (seen from flywheel side)
Isochronous speed regulator	Electronically managed
Dry weight	~630 kg (G-Drive)

Electrical system 12 V

Accumulator/s	
- capacity	180 Ah or above
- discharge current	800 A or above

Performance (*) NEF67 TE1F

Stage IIIA	Prime	131.5 kWm @ 1500 rpm
	Stand-by	145 kWm @ 1500 rpm

Performance (*) NEF67 TE2F

STAGE IIIA	Prime	150 kWm @ 1500 rpm
	Stand-by	165 kWm @ 1500 rpm

Performance (*) NEF67 TE3F

STAGE IIIA	Prime	175 kWm @ 1500 rpm
	Stand-by	195 kWm @ 1500 rpm

(*) Net power to the flywheel in compliance with ISO 3046-1. Test conditions: T 25 °C; atmospheric pressure 100 kPa; relative humidity 30%.



It is severely prohibited, under penalty of cancellation of the warranty and of the responsibilities of FPT, to change the characteristics indicated above.

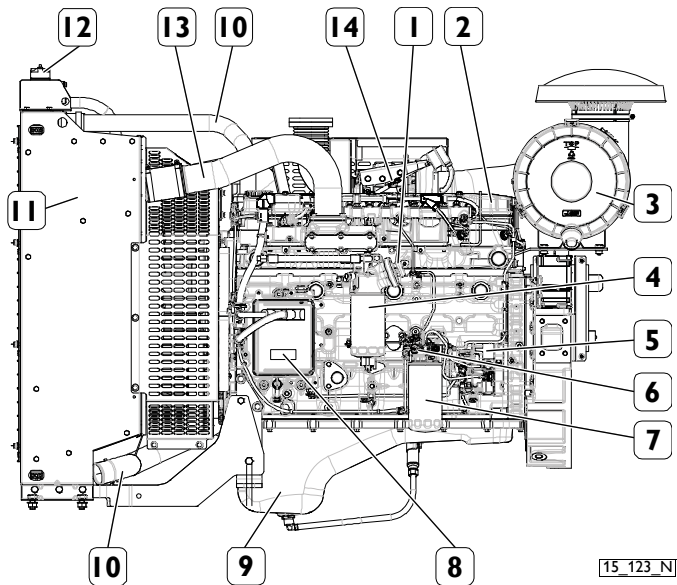

15 123 N

NEF67 TE1F/TE2F/TE3F

1. Air breather pipe from fuel pre-filter - 2. Tappet cover - 3. Air filter - 4. Fuel pre-filter - 5. Injection pump - 6. Fuel temperature sensor - 7. Fuel filter - 8. EDC electronic control unit - 9. Oil sump - 10. Engine evacuation pump - 11. Radiator - 12. Engine cooling water filling cap - 13. Air hose - 14. Turbocharger

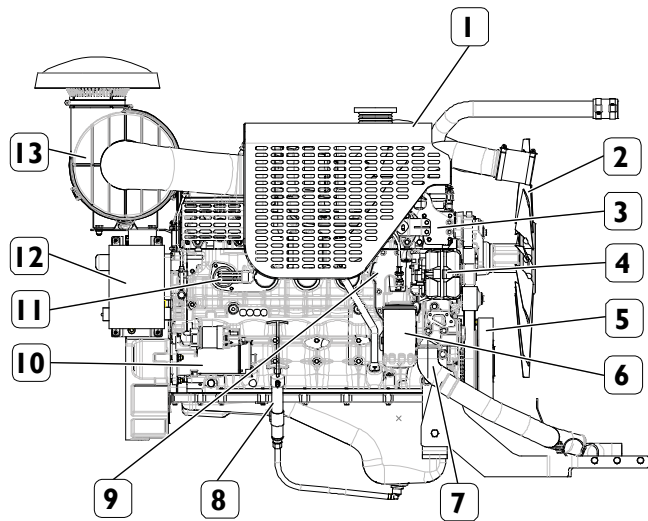

15 124 N

NEF67 TE1F/TE2F/TE3F

1. Turbocharger heat guard - 2. Fan - 3. Lifting eyelet - 4. Alternator - 5. Crankshaft pulley - 6. Oil filter - 7. Water filling pipe - 8. Oil evacuation pump - 9. Heat exchanger - 10. Starter motor - 11. Water cooling pre-heating element - 12. Completion kit - 13. Air filter

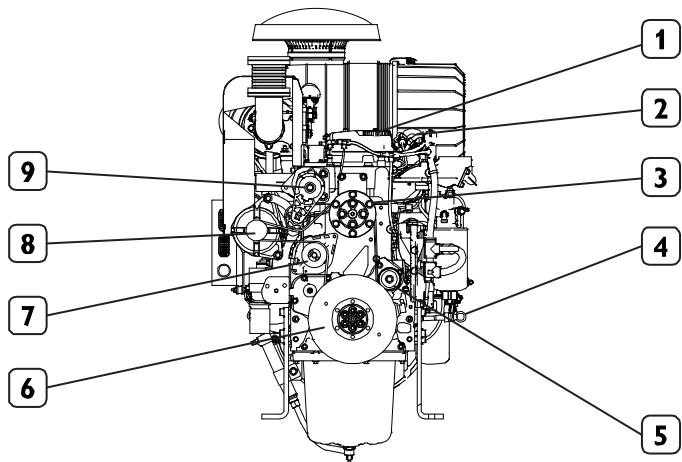

14 089 N

NEF67 TE1F/TE2F/TE3F

1. Oil filling cap - 2. Fuel pipes - 3. Fan pulley - 4. Oil level dipstick - 5. Guide pulley belt tensioner - 6. Crankshaft pulley - 7. Water pump - 8. Alternator - 9. Automatic belt tensioner

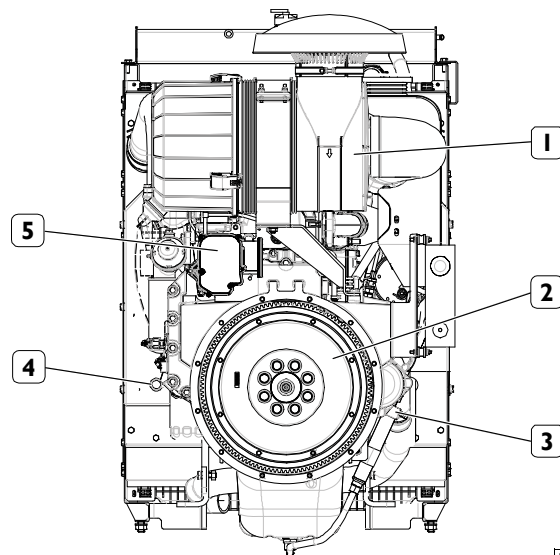

15 125 N

NEF67 TE1F/TE2F/TE3F

1. Air filter - 2. Engine flywheel - 3. Oil evacuation pump - 4. Oil level dipstick - 5. Oil vapour filter housing

SIGNS

Certain warning signs are affixed to the engine by the Manufacturer, and their meanings are indicated below.

Note: The signs with an exclamation mark on them underline a potential **danger**.



Lifting point (engine only).



Fuel Cap
(on the fuel tank, if there is one).



Oil Cap.



Oil dipstick.



Danger of burning:
Expulsion of hot water under pressure.



Danger of burning:
Presence of high temperature parts.



Danger of fire:
Fuel present.

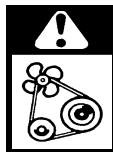

Danger of impact or catching
on moving parts:
Presence of fans, pulleys, belts or the like.

■ USE

PRELIMINARY CHECKS

Before starting the engine each time:

- ❑ Check the level of technical fluids (fuel, engine oil and coolant), and top-up if necessary.
- ❑ Make sure that the air intake filter is not obstructed or clogged, checking at the same time that the mechanical indicator on the filter does not show the “red” signal. If the engine has an electric clogging sensor, the alarm will be produced upon start due to the luminous indicator placed on the instrument panel.

Note: The procedures required to clean the filter are indicated in the CONTROLS AND MAINTENANCE chapter.

CAUTION!



Make sure that no combustible vapours or gasses are present in the area in which the engine is to operate. Ensure that closed areas are adequately ventilated and fitted with a suitable exhaust extraction system.

STARTING AND STOPPING THE ENGINE

The methods for starting and stopping the engine described as follows refer to a vehicle fitted with an FPT produced instrument panel. The methods for starting and stopping shall vary, if the equipment or vehicle manufacturer has created a customised dashboard, depending on the various options operated by such.

In these cases, refer to what is indicated in the specific documentation for information regarding the start and stop sequences and the interpretation of the indicator instruments.

ENGINE PRE-HEATING (optional)

(Electrical device)

Engines that must start at low temperatures and immediately deliver power can be equipped with an electric heating device, which makes it possible to raise or maintain the coolant temperature at suitable values.

The device is equipped with a thermostat to stop the electrical power supply when the foreseen temperature is reached.

FOR PROPER USE OF THE ENGINE

- ❑ Before starting the engine, check there is enough fuel in the fuel tank.
- ❑ Do not keep on starting.
- ❑ Do not idle for long periods since this increases the production of harmful emissions from the engine and does not guarantee its optimum performance.
- ❑ During use, check periodically that:
 - the temperature of the engine coolant does not reach the alarm thresholds;
 - the oil pressure remains within normal values.
- ❑ Actual power values must comply with the rated values reported in the technical documentation.
- ❑ Particular attention must be drawn on emergency power unit engines, which must be submitted to frequent overhauls in order to ensure their prompt start whenever required.

SPECIAL WARNINGS

High coolant temperature

In the event of an excessive temperature or the signalling of the alarm, disengage the load and stop the engine in order to check the condition of the cooling circuit.

Moreover, check the following:

- ❑ the tension of the ancillary belt;
- ❑ the thermostatic valve's efficiency;
- ❑ the conditions of the heat exchanger (to be cleaned if necessary).

CAUTION!



When the engine is hot, pressure builds up in the cooling circuits which may eject hot liquid violently, resulting in a risk of burns. Open the filler cap of the coolant tank only if necessary and only when the engine is cold.

Low lubricant oil pressure

Should the pressure indicated by the instrument be considered insufficient or if the "low oil pressure" warning light comes on, stop the engine and check the oil level. If necessary, top up the oil according to the instructions contained in CHECKS AND MAINTENANCE section. If the fault persists, contact a Service centre.

Presence of water in the fuel filter

It is advisable to drain the water from the filters before the relevant warning light comes on.

Avoid using the engine with only a small reserve of fuel in the fuel tank; this encourages the formation of condensation and makes it more likely you will suck up dirt or air, resulting in engine stoppage.



Refuelling from drums or jerry cans may contaminate the diesel, resulting in problems with the fuel supply system; in these cases it is necessary to carry out adequate filtration or sedimentation of any impurities present.

CAUTION!



Never loosen the high pressure fuel circuit connectors in any way.

Intake and exhaust circuit inefficiencies

Inspect the cleanliness of the air intake circuit on a regular basis. The maintenance intervals indicated in this manual vary according to the conditions in which the engine is used.

In particularly dusty environments it is necessary to carry out maintenance at more frequent intervals than indicated in the CONTROLS AND MAINTENANCE chapter.

CAUTION!



Visually check that the exhaust circuit is not blocked or damaged, so as to prevent dangerous fumes.

Electrical start-up system irregularities

Periodically check, particularly during the winter, to ensure that the batteries are clean and in full working order, checking and topping up as indicated in the CONTROLS AND MAINTENANCE chapter.

In the event of battery replacement, please observe the characteristics contained in the ENGINE TECHNICAL DATA section.



Contact a specialised workshop and check battery and recharging system efficiency if the voltmeter indicates a voltage below 11 V (for 12 V rated systems), or 22 V (for 24 V rated systems).

CAUTION!



The batteries contain an acid solution that will burn the skin and corrode clothing; when checking them, always wear protective clothing, gloves and goggles, do not smoke or use live flames in the vicinity, and make sure that the room they are housed in is adequately ventilated.

Battery or alternator recharging faults

Periodically check or have someone check the cleanliness, wear and full tensioning of the drive belt.

CAUTION!



The ancillary members are located under protective grilles. Their removal must be carried out only when the engine is not turning.

RUNNING IN

Thanks to modern engine construction technology, no particular running in procedure is required. However, it is recommended that, for the first 50 hours, you do not use the engine at high power for long periods.

REFILLING

Parts to be supplied

NEF45
litres (kg)

Cooling circuit ⁽¹⁾	engine ⁽⁴⁾	8,5
	G-Drive ⁽⁵⁾	18,5
<hr/>		
Lubrication circuit ⁽²⁾		
total capacity ⁽³⁾		12.8 (11.8)
<hr/>		
Periodic changing:		
oil sump at minimum level		5.5 (4.95)
oil sump at maximum level		8.5 (7.65)
<hr/>		
Fuel tank		-
<hr/>		

		NEF67 TE1F	NEF67 TE2F
		NEF67 TM1F	NEF67 TE3F*
		litres (kg)	litres (kg)
Cooling circuit ⁽¹⁾	engine ⁽⁴⁾	10.5	10.5
	G-Drive ⁽⁵⁾	25.5	25.5
Lubrication circuit ⁽²⁾ total capacity ⁽³⁾		17.2 (15.48)	17 (15.3)
Periodic changing: oil sump at minimum level oil sump at maximum level		8 (7.2)	8 (7.2)
		12 (10.8)	15 (13.5)
Fuel tank		-	-

(1) Use a 50% mixture of water and PARAFU 11 or the equivalent corresponding to the specification SAE J1034.

(2) The oil used is considered to be acceptable until a quantity equalling 0.1% of fuel consumption is reached. Use lubricants that comply with international specifications SAE 10W-40/15W-40 ACEA E7/E9; API CI-4/CJ-4; 5W-30 ACEA E4/E6 (for fuel economy benefits). FPT suggest to use original Urania LD7 / Urania LD9 lubricant oil.

* For NEF67TE3F model it is mandatory to use lubricants that comply with international specifications SAE 10W-40 ACEA E9 API CJ-4. FPT suggest to use original Urania LD9 Lubricant oil.

(3) The quantities indicated relate to the first refill only and are relative to the engine, oil sump and filter filling.

(4) The quantities indicated only relate to the engine in its standard configuration.

(5) The quantities indicated relate to the total capacity of the G-Drive including the engine capacity.

Coolant refilling

For the initial engine start-up and in the cases in which the refilling of the cooling circuit is required with a considerable quantity of coolant, proceed as follows:

- Refill the engine and the exchanger until the exchanger is completely filled.
- With the coolant filler plug open, start the engine and let it idle for approx. 1 minute. This helps to completely bleed the air contained in the cooling circuit.
- Stop the engine and then top up with coolant if necessary.



The failure to observe the aforesaid procedure does not guarantee the presence of the correct quantity of coolant in the engine.

WARNING

When the engine is hot, pressure builds up in the cooling circuits which may eject hot liquid violently, resulting in a risk of burns. Open the filler cap of the coolant tank only if necessary and only when the engine is cold.

Refuelling

Use only diesel oil in accordance with EN 590 standard normally commercially available. Fuel additives are not recommended.

Use of additives can limit the guarantee performance offered for the vehicle.

WARNING

Pay maximum attention when refuelling, making sure that solid or liquid pollutants do not enter the tank; please remember that smoking is prohibited while refuelling. The couplings of the fuel circuit under high pressure must not be loosened under any circumstances.

Low temperature diesel

At low temperatures the degree of fluidity of the diesel can become low due to the separation of the paraffin resulting in the filters becoming clogged.

EN590 specifications distinguish different classes of diesel fuel, identifying the characteristics of those best suited to low temperatures. It is entirely up to the Oil companies to comply with these regulations, which foresee that fuels suited to the climactic and geographic conditions of the various Countries be distributed.

■ CONTROLS AND MAINTENANCE

MAINTENANCE PERSONNEL

The engine control and maintenance operations described in the following chapter require training, experience and compliance with current safety regulations; for this reason they must be carried out by special technicians, as indicated below.

- Controls:** by workshop technicians or the machine user if necessary.
- Periodic maintenance:** by qualified personnel using suitable equipment and adequate means of protection.
- Special maintenance:** by qualified personnel from Authorised Service Centres who have detailed technical information and specific equipment.



The most qualified Assistance Centres are those which make up the FPT Technical Assistance Network.

ACCIDENT PREVENTION

- Always wear heavy-duty footwear and overalls.
- Never wear loose, flapping garments, rings, bracelets and/or necklaces in the vicinity of engines or moving parts.
- Always wear protective gloves and goggles when:
 - filling up batteries with acid solution
 - check cleanliness of battery clamps and terminals
 - refuelling with inhibitors or antifreeze

- replacing or topping up lubricant (hot engine oil may cause burns and scalds. Only carry out these operations when the oil has dropped to a temperature of below 50°C).
- When working in the engine compartment, pay particular attention to how you move, to avoid contact with moving parts or high temperature components.
- Wear goggles and use high pressure air jets (maximum air pressure used to clean is 200 kPa (2 bar, 30 psi, 2 kg/cm²).
- Wear a protective helmet when working in an area where there are suspended loads or systems installed at head-height.
- Use protective hand cream.
- Immediately replace wet overalls.
- Always keep the engine clean, removing oil, grease and coolant stains.
- Store cloths in flame-proof containers.
- Do not leave foreign bodies on the engine.
- Use suitable, safe containers for used oil.
- When completing a repair, make suitable provisions to stop the engine taking in air if, after start-up, an uncontrolled increase in engine speed were to occur.



Do not carry out maintenance operations when the electric power supply is turned on: always check to ensure that the appliances are properly earthed. During diagnosis and maintenance operations, make sure that your hands and feet are dry, and whenever possible use insulating stands.



The conditions provoking the emergency power unit start may suddenly occur. Whenever executing checks and maintenance operations, strictly follow the safety instructions prescribed by the unit's Manufacturer and power unit system's outfitter to operate safely and prevent injury.

FREQUENCY

Controls (when in use)	Frequency
Check oil level in engine	Daily
Check coolant level	Daily
Check that the heat exchangers are clean	Daily
Check air filter and housing Cleanliness	Monthly
Check state and tension of belt	300 hours ⁽²⁾
Check/top up electrolyte level in batteries and clean terminals	Half-yearly
Check exhaust pipe/s for damage	Half-yearly

The maintenance intervals indicated below take into account the typical working factors for various types of engine use; the most suitable interval for maintenance operations for the various applications will be indicated by the maintenance staff, according to the way and working conditions in which the engine is used.



Planned maintenance

Frequency

Change oil	600 hours ⁽³⁾ ⁽⁴⁾
Change oil filter/s	600 hours ⁽³⁾ ⁽⁴⁾ ⁽⁵⁾
Change fuel filter/s	600 hours ⁽³⁾ ⁽¹⁾ ⁽⁵⁾
Change fuel pre-filter	600 hours ⁽³⁾ ⁽¹⁾
Replacing the blow-by filter	900 hours ⁽³⁾ ⁽⁴⁾
Drain water from the fuel pre-filter	150 hours ⁽¹⁾
Impurity drainage/suction from the fuel tank	150 hours ⁽¹⁾
Change air filter	1200 hours/ 2 years ⁽⁶⁾
Change coolant	1200 hours or 2 years



Special maintenance

Frequency

Visual inspection of turbocharger	1200 hours
Change auxiliary member belt	1200 hours
Cleaning of heat exchangers	1200 hours
Injector calibration (Mechanical motors)	1800 hours
Adjustment of valve/rocker arm clearance	3000 hours

- 1) Maximum period when using good quality fuel, (EN 590 standard); this is reduced if the fuel is contaminated and alarms are triggered due to blockage of the filters and presence of water in the pre-filter. When blockage of the filter is indicated, it must be replaced. If the water in pre-filter indicator does not go out after drainage, the pre-filter must be replaced.
- 2) Refers to engines with traditional and automatic tensioning devices
- 3) Must be performed annually, even if the required number of working hours are not reached
- 4) Frequencies valid for lubricants as specified in the REFILLING chart.
- 5) Only use filters with the following characteristics:
 - filtration level $< 12 \mu\text{m}$
 - filtering efficiency $\beta > 200$.
- 6) The frequency with which operations are carried out will depend on the working conditions and efficiency/wear of the product.

WARNING



The extraordinary maintenance operations described hereunder fall within the exclusive competence of manufacturer's personnel or specialised personnel having proper working tools and adequate protection devices. The procedure and modality for carrying out these operations are illustrated in the FPT Technical and Repair Manual.



In the event in which fuel is used with a sulphur percentage greater than 0.5%, or oils are used which do not meet the specifications in the REFILLING section, then the replacement frequencies of the engine oil, engine oil filter and blow-by filter must be halved, or suitably adjusted, in accordance with the use and operating conditions of the engine; please consult the personnel in charge of maintenance operations for appropriate advice.



The operations described above require the use of specific tools which guarantee safe and effective results.

It is recommended that such operations are carried out by qualified personnel of the FPT Technical Service Network.

The unscheduled maintenance operations described in the relative table are under the exclusive responsibility of qualified personnel in possession of suitable technical information and equipped with suitable work tools and protective devices. The instructions for their fulfillment are contained in the FPT Technical and Repair Manuals.

REQUIREMENTS

- ❑ Do not disconnect the batteries with the engine running.
- ❑ Do not carry out arc welding operations in the vicinity of the engine without first removing electrical cables.
- ❑ After each maintenance operation involving disconnection of the battery/batteries, make sure that the terminals have been properly locked onto the poles.
- ❑ Do not use battery chargers to start the engine.
- ❑ Do not paint the appliances, components and electrical connectors equipping the engine.
- ❑ Disconnect the battery/batteries before any electrical operations.
- ❑ Contact the Manufacturer before installing electronic equipment.



*Do not execute any operation which may change the injection pump calibration.
The injection pump calibration has been carried out in phase of engine system test based on its final use or destination.*

CHECKS TO BE MADE DURING PERIODS OF USE - HOW TO PROCEED

Check oil level in engine

Only proceed with the engine stopped and at a low temperature, so as to avoid the risk of burning.

- ❑ Use the oil dipstick (1) to check that the lubricant oil level is between the "Min" and "Max" limits.
- ❑ If the level is insufficient, it is necessary to top up with lubricant oil which meets the international specifications ACEA E5/E7 (high power engines), as indicated in the REFILLING section. Remove the lubricant oil cap (2) and pour engine lubricant oil through the hole.
- ❑ Use the oil dipstick (1) to check that the lubricant oil level does not exceed the "Max" limit.

NEF45 SM1F/TE1F/TE2F

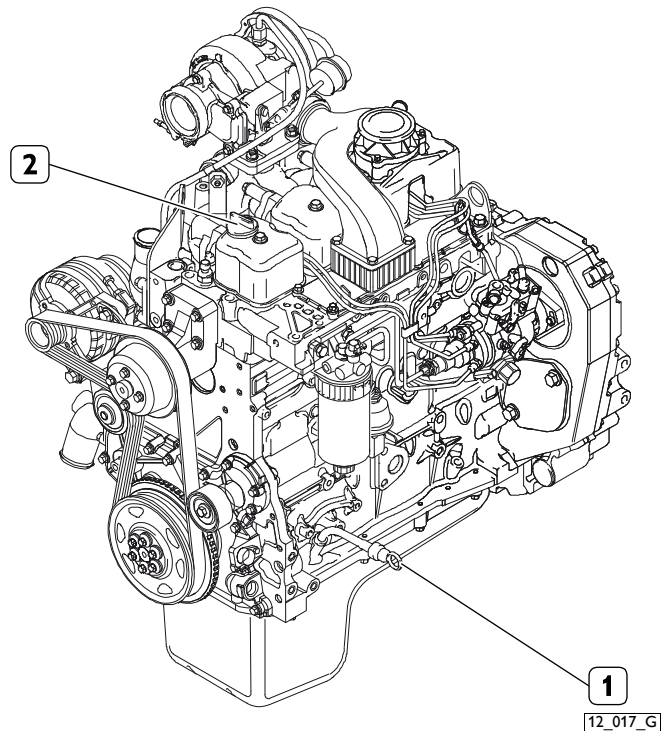

NEF67TM1F/TE1F/TE2F/TE3F

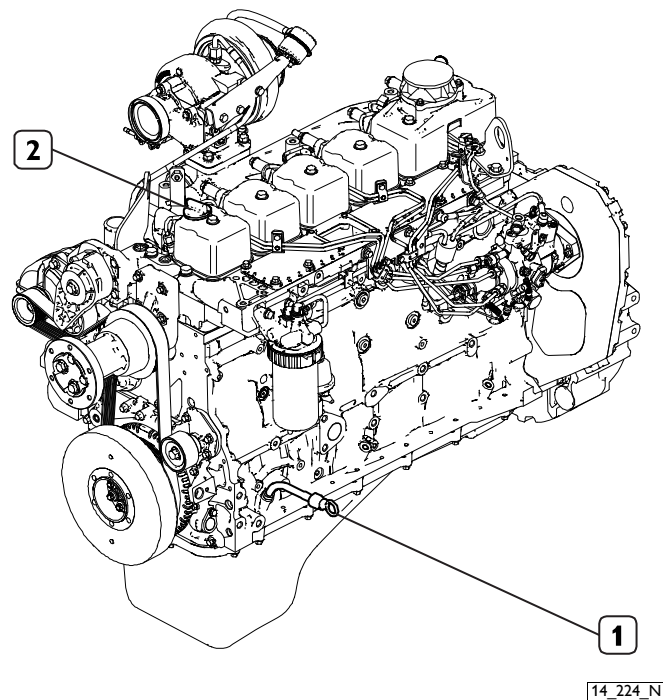

Check coolant level

Proceed only with engine not running and at low temperature to avoid any risk of burns.

- ❑ Remove the pressurization cap from the expansion tank.
- ❑ Check that the coolant in the expansion tank is above the minimum level.
- ❑ If necessary, top up the expansion tank with a mixture of 50% water and PARAFLU 11, as contained in the REFILLING section. Do not fill the expansion tank to the brim.
- ❑ When the engine is cold, make sure that the coolant level is a few centimetres below the filling hole.

In the event of an externally located level indicator as regards the heat exchangers, proceed with the top up operation by making sure that the coolant does not overflow the internal volume of the exchanger in order to allow the expansion of coolant volume during increases in temperature.



If frequent top-ups are necessary, the cooling circuit must be diagnosed.

Clean heat exchangers

Check that the radiator air inlets are free from dirt (dust, mud, straw, etc.).

Clean them if necessary, using compressed air or steam.

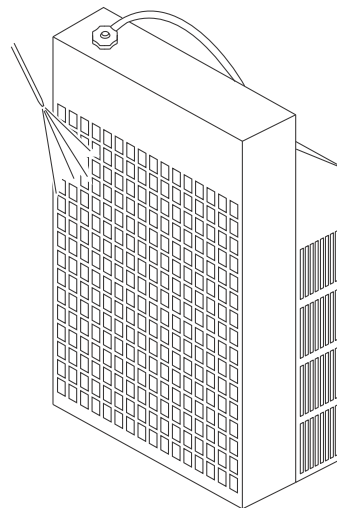

05_609_N

Check tension and state of the auxiliary member drive belt

Only proceed with the engine stopped and at a low temperature, so as to avoid the risk of burning.

NEF45 SM1F/TE1F/TE2F

- ❑ Remove any casing protecting the pulleys.
- ❑ Check that the belt is not torn or worn, and that there are no lubricants or fuel on it. If this is not the case, replace them.
- ❑ At the same time, make sure that the tensioning device is working properly, proceeding as indicated in the figure.
- ❑ Replace the guard casing in its housing, and lock all the retaining elements.

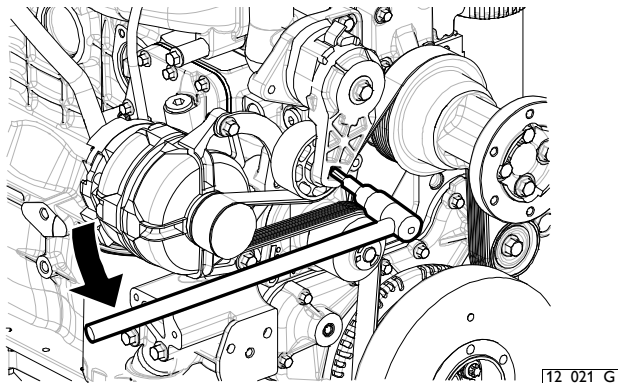

Inspection of the exhaust duct/s

Visually check that the exhaust gas / exhaust system is not obstructed or damaged.

- ❑ Make sure that there is no danger from harmful fumes in the environment where the engine is being worked on. Contact the manufacturer if necessary.

Check tightening and cleanliness of battery clamps

Check that the battery terminals and cable clamps are clean, well tightened and protected by Vaseline.

In the event of dirty cable clamps and battery terminals:

- ❑ Loosen the nut and remove the clamp from the negative terminal (indicated by the "-").
- ❑ Loosen the nut and remove the clamp from the positive terminal (indicated by the "+").
- ❑ Use a metal brush or fine grade emery paper to clean the cable clamps and battery terminals until they are shiny.
- ❑ Smear the cable clamps with Vaseline and insert them onto the battery terminals making sure that the positive pole is connected first, followed by the negative pole, and then tighten each clamp.

Check the cables and clamps for signs of wear and corrosion; replace them if in poor condition.

Visually check the condition of the battery: the terminals must not show signs of deterioration and the body must not be damaged, otherwise they should be replaced.



Wear protective glasses and gloves.

Check electrolyte level of the batteries

The batteries used are of reduced maintenance type. Therefore, under normal conditions of use, no top up of the electrolyte is required. However, the routine checking of the electrolyte level is recommended. Proceed after positioning the batteries on a horizontal surface.

- ❑ Visually check that the electrolyte level is between the "Min" and "Max" reference marks on the batteries; in the absence of any reference marks, make sure the liquid covers the lead plates contained in the elements by approx. 5 mm.
- ❑ Only use distilled water to top up the elements whose level is below the minimum.
- ❑ If the battery requires recharging, contact a specialised workshop.



A specialised workshop should be contacted if all the battery elements need topping up with a considerable quantity of distilled water and the diagnostics of the battery recharging system's efficiency should be performed.



The batteries contain sulphuric acid which is highly caustic and corrosive; during the top up operations protective glasses and gloves must be worn, as well as an apron to protect clothing. If possible, have this check performed by qualified personnel.

CAUTION!



During the checks do not smoke or allow naked flames near the batteries. Ensure that the work area is suitably ventilated.

Some batteries have a single cover for the inspection plugs. To access the elements, use a lever as shown in the figure.

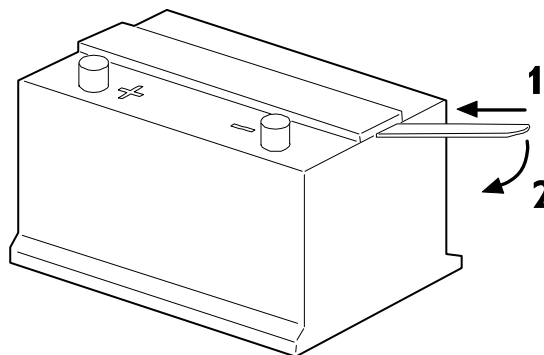

13_052_C

Check condition of the blow-by filter

Only proceed when the engine is not turning and is at low temperature so as not to run the risk of burns.

- ❑ Remove the blow-by filter (1) from the tappet cover (3) of the cylinders no. 5-6, by unscrewing the three fastening screws.
- ❑ Check that the blow-by filter (1) is free from deposits, otherwise replace it.
- ❑ Reposition the blow-by filter (1) in its seat on the tappet cover (3) of the cylinders no. 5-6.

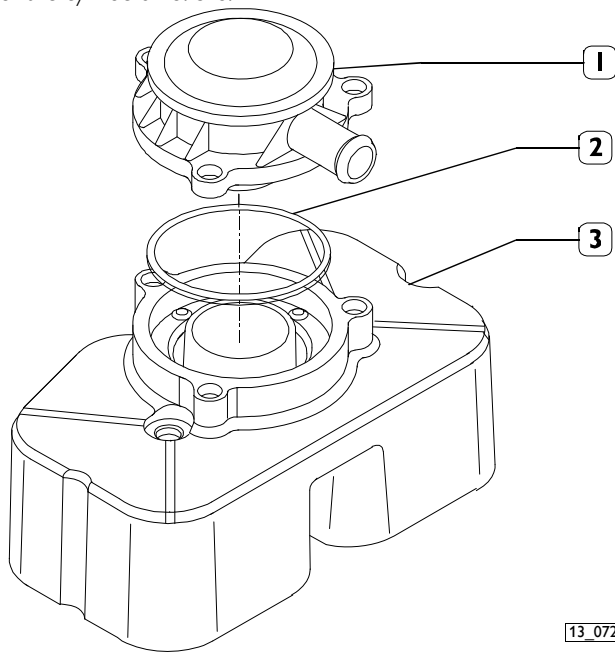

13_072_N



Eliminate the consumables and any materials in contact with them (for example, filters) in accordance with current regulations. The FPT Technical Service Network workshops are equipped for this purpose.

Check exhaust pipe/s for damage

Visually check that the exhaust system is not blocked or damaged.

- ❑ Make sure that there is no risk of dangerous fumes within the machine. Contact the Manufacturer if necessary.

PLANNED MAINTENANCE - HOW TO PROCEED

Engine lubricant oil change

Only proceed when the engine is not turning and is at low temperature so as not to run the risk of burns.

- ❑ Place a suitable container for collecting the spent oil under the oil sump next to the lubricant oil drain plug (see the figures in the ENGINE TECHNICAL DATA section).
- ❑ Unscrew the lubricant oil drain plug; afterwards extract the oil level dipstick (1) and remove the lubricant oil cap (2) to assist the flow of the engine lubricant oil.
- ❑ Wait until the oil sump has completely emptied, then retighten the lubricant oil drain plug.
- ❑ Proceed with the refilling operation through the hole situated on the tappet cover of cylinder no. 1, using lubricant oil that meets the international standards ACEA E5/E7 (high power engines), as indicated in the REFILLING section.
- ❑ Use the oil dipstick (1) to check that the lubricant oil level does not exceed the "Max" limit.
- ❑ Retighten the lubricant oil cap (2).
- ❑ Together with the replacement of the engine lubricant oil it is necessary to replace the oil filter (see OIL FILTER REPLACEMENT paragraph).

NEF45 SM1F/TE1F/TE2F

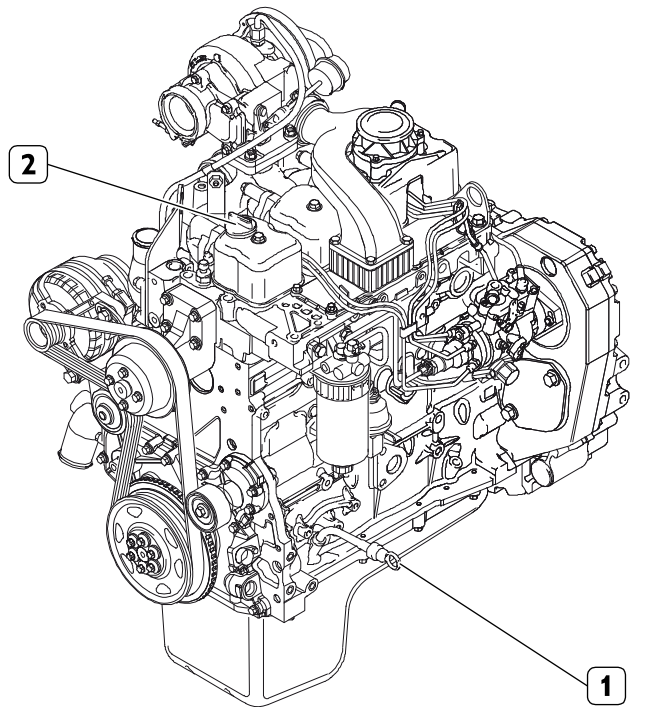

12_017_G

NEF67TM1F/TE1F/TE2F/TE3F

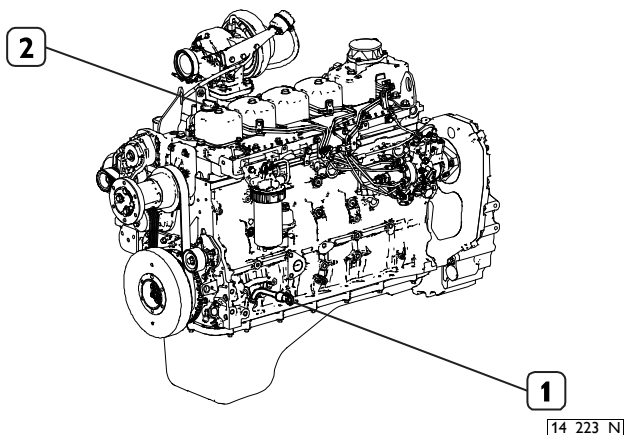

Make sure that the oil dipstick is fully inserted and that the oil filler cap is fully tightened in a clockwise direction.



Eliminate the consumables and any materials in contact with them (for example, filters) in accordance with current regulations. The FPT Technical Service Network workshops are equipped for this purpose.

Oil filter change

Only use filters with the following specifications (see the FREQUENCIES section):

- degree of filtering $< 12 \mu\text{m}$
- filtering efficiency 99.5% ($\beta > 200$).

Only proceed when the engine is not turning and is at low temperature so as not to run the risk of burns.

- Proceed with the emptying of the spent oil (see ENGINE LUBRICANT OIL CHANGE paragraph).
- Place a container for collecting the spent oil under the filter support (1).
- Remove the filter (3) by unscrewing it from its relative support.
- Replace the filter element and the O-ring seal (2) contained inside the filter (3).
- Carefully clean the surfaces of the support (1) in contact with the O-ring seal (2).
- Smear the O-ring seal (2) of the new filter with oil.
- Screw the new filter (3) onto the support (1).

NEF45 SM1F/TE1F/TE2F

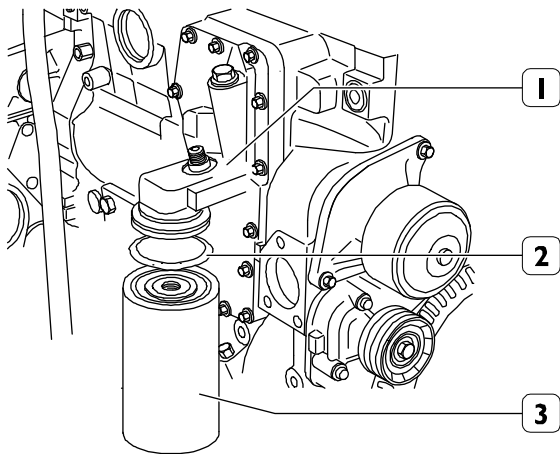

14_222_N

NEF67TM1F/TE1F/TE2F/TE3F

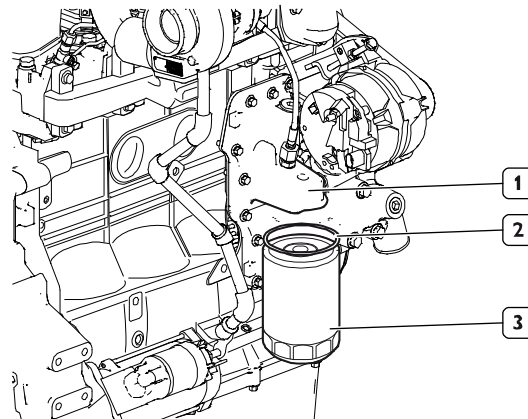

13_073_N



Eliminate the consumables and any materials in contact with them (for example, filters) in accordance with current regulations. The FPT Technical Service Network workshops are equipped for this purpose.

Fuel filter change

Only use filters with the following specifications (see the FREQUENCIES section):

- degree of filtering <math>< 12 \mu\text{m}</math>
- filtering efficiency 99.5% ($\beta > 200$).

Only proceed when the engine is not turning and is at low temperature so as not to run the risk of burns.

- ❑ Place a container for collecting the diesel under the filter support (1).
- ❑ Remove the filter (2) by unscrewing it from its relative support.
- ❑ Replace the filter element and the O-ring seal contained inside the filter (2).
- ❑ Carefully clean the surfaces of the support (1) in contact with the O-ring seal.
- ❑ Smear the O-ring seal of the new filter with oil.
- ❑ Screw the new filter (2) onto the support (1).

NEF45 SM1F/TE1F/TE2F

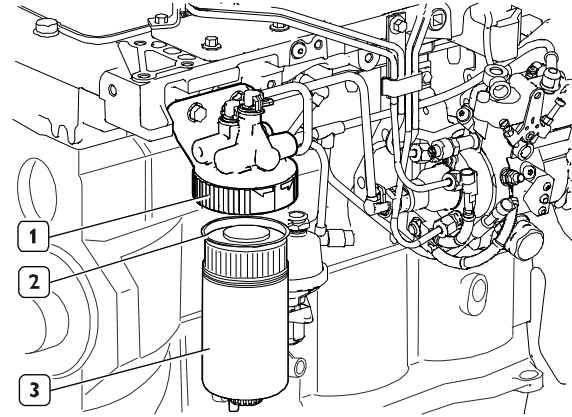

13_070_N

NEF67TM1F/TE1F/TE2F/TE3F

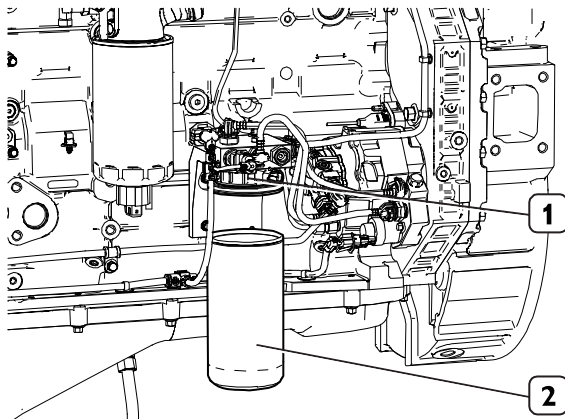

14 218 N

CAUTION!



Pay attention to the electric fuel pre-heater (if installed) and the relative electrical connection.

Residual air bleeding procedure:

- Loosen the fuel outlet coupling (1) located on the top of the filter.
- Make sure that the discharge of diesel does not soil the ancillary belt and does not leak into the surroundings.

- Use the fuel suction pump (2) until the diesel coming out is free from any residual air.
- Correctly tighten the previously loosened coupling.
- Start the engine and let it run idle for a few minutes to remove any residual air.

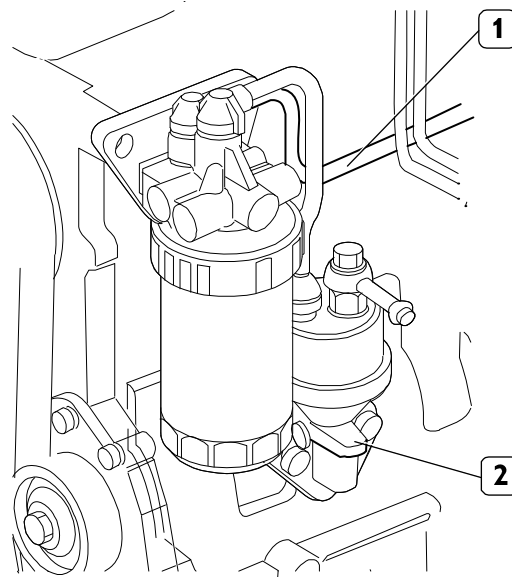

13 075 N



Do not fill the new fuel filter before placing it on the support in order to prevent harmful impurities from entering the fuel circuit and the injection system.



Eliminate the consumables and any materials in contact with them (for example, filters) in accordance with current regulations.
The FPT Technical Service Network workshops are equipped for this purpose.

Changing the fuel pre-filter

Only proceed with the engine stopped.

- Should the filter be fitted with a sensor to detect the presence of water (3), remove the whole sensor from its seat.
- Remove the pre-filter by unscrewing it.
- Check that the new filter has performance levels that satisfy the needs of the engine (e.g. by comparing them with the old one).

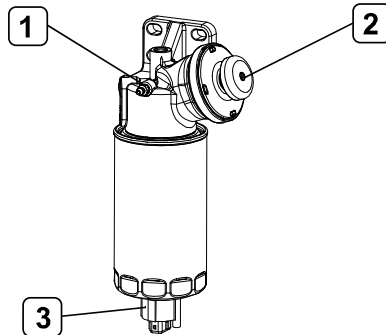

08_012_F

- Damp the new filter seal with diesel or engine oil.
- Hand screw the new filter into place until the seal gasket touches the support, then lock by a further 3/4 of a turn.
- Place the water presence sensor in its seat, taking care to couple the threads correctly.
- Loosen the bleeder screw (1) on the pre-filter support and activate the hand pump (2) until the supply circuit is full. Ensure that any fuel coming out is not dispersed into the environment.
- Lock the bleeder screw tightly.
- Start the engine and run it at idle for a few minutes to eliminate any residual air.
- Check the efficiency of the earthing connection of the filter support.

Note: Should it be necessary to accelerate the bleeding phase, the hand pump can be used during start-up.

Blow-by filter change

Only proceed when the engine is not turning and is at low temperature so as not to run the risk of burns.

- ❑ Remove the blow-by filter (1) from the tappet cover (3) of the cylinders no. 5-6, by unscrewing the three fastening screws.
- ❑ Replace the blow-by filter (1) and the relative gasket (2).
- ❑ Reposition the new blow-by filter (1) in its seat on the tappet cover (3) of the cylinders no. 5-6.



Eliminate the consumables and any materials in contact with them (for example, filters) in accordance with current regulations.
The FPT Technical Service Network workshops are equipped for this purpose.

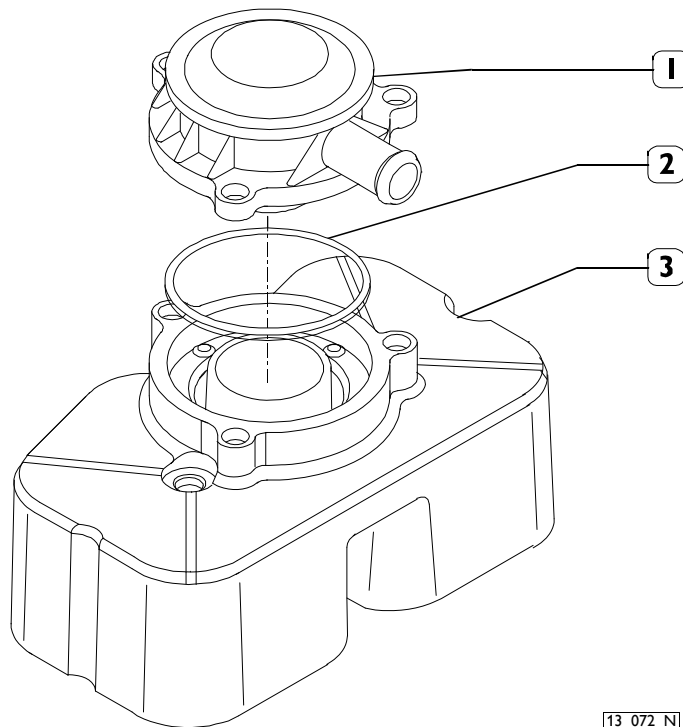

13_072_N

Drain water from the fuel filter/pre-filter

The high risk of refuelling with fuel that is polluted by foreign bodies and water makes it advisable to carry out this control every time you refuel.

Proceed with the engine stopped.

- ❑ Place a container under the filter or pre-filter to collect the fluid.
- ❑ Unscrew the tap plug (1) in the bottom part of the filter; in some lay-outs the plug includes a sensor to detect the presence of water in the diesel.
- ❑ Drain off liquid until only "diesel" can be seen.
- ❑ Close the plug again, tightening it completely by hand.
- ❑ Dispose of the drained fluids according to current requirements.

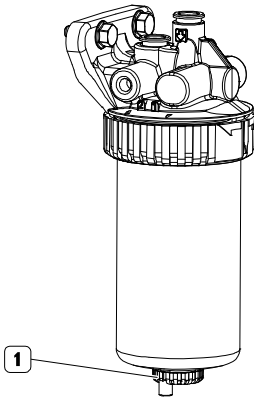

12_020_G

Impurity drainage or suction from fuel tank

Proceed as necessary based on the structure or location of the tank. Engines that operate in adverse environments and conditions and/or that are refuelled using drums or jerry cans, require more attention when cleaning the tank.

Air filter replacement

Refer to the instructions provided for air filter cleaning.

Change engine coolant

Only proceed when the engine is not turning, and is at low temperature, so as not to run the risk of burns.

- ❑ Place a container for collecting coolant under the heat exchanger (radiator).
- ❑ Remove the pressurization cap from the expansion tank.
- ❑ Loosen the retaining elements and remove the sleeves connecting the engine cooling circuit to the heat exchanger.
- ❑ Drain the coolant from the heat exchanger (radiator) and wait until it is completely empty.
- ❑ Once emptied, refit the cooling circuit making sure the sleeves are perfectly sealed.
- ❑ Refill the engine and the heat exchanger until the cooling circuit has been completely refilled using a mixture of 50% water and PARAFLU 11, as contained in the REFILLING section. Do not fill the expansion tank to the brim.
- ❑ With the coolant cap open, start the engine and let it idle for approx. one minute. This helps to completely bleed the air contained in the cooling circuit.
- ❑ Stop the engine and top up with more coolant, if necessary.
- ❑ When the engine is cold, make sure that the coolant in the expansion tank is a few centimetres below the filling hole.

In the event of an externally located level indicator as regards the heat exchangers, proceed with the top up operation by making sure that the coolant does not overfill the internal volume of the exchanger in order to allow the expansion of coolant volume during increases in temperature.



The failure to observe the aforesaid procedure does not guarantee the presence of the correct quantity of coolant in the engine.

CAUTION!



When the engine is hot, pressure builds up in the cooling circuits which may eject hot liquid violently, resulting in a risk of burns. Open the filler cap of the coolant tank only if necessary and only when the engine is cold.

UNSCHEDULED MAINTENANCE - HOW TO PROCEED

Change ancillary belt

Only proceed when the engine is not turning and is at low temperature so as not to run the risk of burns.

- ❑ Remove the protective grilles and the fan together with spacer by undoing the relative fasteners.
- ❑ Loosen the bolt (1) anchoring the alternator to its lower support and the screw (2) fastening the alternator to the bracket.
- ❑ Using the tool (3), rotate the automatic belt tensioner (4) in the direction of the arrow and remove the belt (5).
- ❑ Fit the new ancillary belt inside the shoulders of all the pulleys.
- ❑ Reposition the fan together with spacer in its seat and the protective grilles and tighten the relative fasteners.

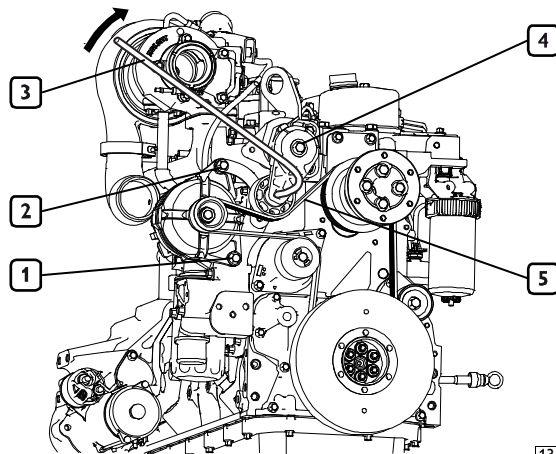

Replace the ancillary belt if it shows signs of abrasions, cracks or tears or if it is soiled with oil or fuel.



CAUTION!

When the engine is off, but still hot, the belt may start to move without warning. Wait for the engine temperature to decrease to prevent serious danger of an accident.

Visual inspection of turbocharger

Only proceed when the engine is not turning over. Visually check that the turbine and compressor impellers and the relative inlet and outlet ducts are not obstructed or damaged, otherwise replace them.

Clean heat exchanger

The surfaces of the heat exchanger (radiator) come into contact with external air and may be subjected to deposits and impurities. Clean them if necessary using compressed air or steam.

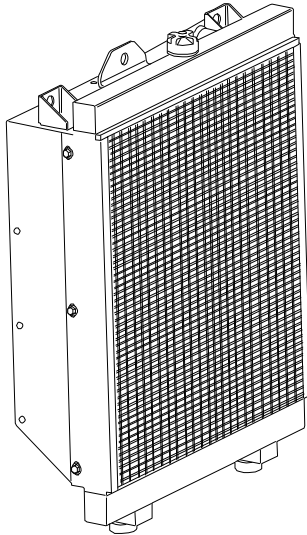

13_068_N



When using compressed air, it is required to use suitable personal protections for hands, face and eyes. The requirements can be found in the ACCIDENT PREVENTION paragraph.

Injector calibration

The injectors require periodic cleaning and calibration of the exact injection pressure, by adding or replacing the shim washers inserted under the spring; check the injection pressure by using a hand operated pump equipped with a pressure gauge which, operated by the lever, enables the injector calibration pressure to be obtained and which is displayed on the pump pressure gauge at the moment in which diesel delivery occurs. During the test it is also possible to note whether the direction of the jet is correct and whether the injectors show any signs of fuel leakage. Clean the injectors using a metal brush to remove the carbon deposits from the nozzle tips.

Adjustment of valve/rocker arm clearance

The adjustment of the clearance between the rocker arms and the intake and exhaust valve control rods must be strictly carried out using an Allen wrench (1), box-end wrench (2) and a feeler gauge (3).

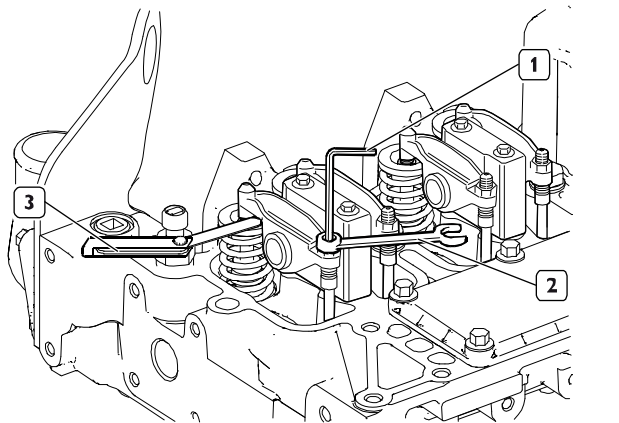

13 087 N

MOVING THE ENGINE

The operations necessary to disconnect and subsequently reconnect the engine must only be carried out by technicians from Service Centres.

When lifting the engine only, use the U-bolts indicated in this manual in the ENGINE TECHNICAL DATA section and marked on the engine with special stickers.

Lifting must be carried out using a rocker arm that keeps the metal cables supporting the engine parallel, using all the U-bolts provided simultaneously; the use of a single U-bolt only is not allowed.

The engine lifting system must have a capacity and size suited to the weight and dimensions of the engine; check that there is no interference between the lifting system and the engine components.

Do not lift the engine before removing the transmission members that are coupled to it.

DISPOSAL OF WASTE

The engine is made up of parts and elements that, if discarded, may cause damage to the environment.

The materials listed below must be handed over to specialised Collection Centres; the laws in force in the various Countries foresee severe penalties for transgressors:

- Starter batteries.
- Used lubricants.
- Mixtures of water and antifreeze.
- Filters.
- Additional cleaning materials (e.g. greasy or fuel-soaked cloths).

■ BEHAVIOUR IN AN EMERGENCY

The user of a machine that has been constructed according to safety regulations, when following the instructions provided in this manual and the indications given on the engine labels, will be working in safe conditions.

Should improper conduct result in accidents, always request the intervention of trained first aid specialists immediately.

In an emergency and while awaiting the arrival of first aid specialists, follow the instructions given below.

In case of fire

Extinguish the fire using the fire-fighting equipment foreseen, and in the manner indicated by Fire prevention authorities (fire-fighting equipment for certain machines and equipment is compulsory under current safety legislation).

Burns and scalds

- Extinguish any flames on the burned person's clothing, by:
 - throwing water over them;
 - using a powder fire-extinguisher, without directing the jet at the person's face;
 - covering with blankets or rolling the victim on the ground.
- Do not attempt to remove pieces of clothing that may have stuck to the skin;
- In the case of scalding, immediately but carefully remove any clothing that may be soaked in the hot liquid;
- Cover the burn with a special burn dressing or sterile bandage.

Carbon monoxide intoxication (CO)

Carbon monoxide from the engine exhaust is without smell, and is dangerous both because it causes intoxication, and because when combined with air it forms an explosive mixture.

In closed rooms, carbon monoxide is extremely dangerous, as it can reach critical concentrations within a very short time.

When assisting an intoxicated person in a closed room:

- Ventilate the room immediately, to reduce the concentration of gas.
- When entering the room, hold your breath, do not light flames, lights or ring electric doorbells or phones, to avoid the risk of explosion.
- Carry the intoxicated person out into the fresh air or into a well ventilated room, resting him on one side if he is unconscious.

Electrocution

The engine's electrical 12 V electrical system does not involve the risk of electrocution, however, in the event of a short-circuit caused, for example, by a metal tool, there is a risk of burning due to overheating of the object through which the electrical current runs. In these circumstances:

- ❑ Remove the object that caused the short-circuit, using means that provide sufficient heat insulation.
- ❑ Switch off the power at the main switch, if there is one.

The electric generator systems (generator units) normally produce high voltages that are liable to result in extremely dangerous current levels. In the event of medium or high voltage electrocution:

- ❑ Turn off the power supply at the main switch before touching the victim. If this is not possible, use equipment that is both safe and adequately insulated when touching the victim; remember that touching a victim of electrocution is also extremely dangerous for the person giving aid.
- ❑ Proceed as indicated by the competent authorities (cardiac massage, mouth-to-mouth resuscitation, etc.)

Injuries and fractures

The vast number of possible circumstances and the specific nature of operations required means that the intervention of a medical team is necessary.

- ❑ In the event of bleeding, keep the edges of the wound pressed together until help arrives.
- ❑ If there is any suspicion of a fracture, do not move the injured part and only move the patient if absolutely necessary.

Caustic burns

Caustic skin burns are caused by contact with extremely acid or alkaline substances.

For personnel performing maintenance on electrical devices, this is typically caused by acid escaping from the batteries; in this circumstance proceed as follows:

- ❑ Remove clothing that has been splashed with any caustic substance.
- ❑ Wash the affected part thoroughly in running water.

If battery acid, lubrication oil or diesel comes into contact with the eyes: wash the affected eye with water for at least 20 minutes, keeping the eyelid open to facilitate the flow of water around the eyeball (and while moving the eye in all directions).