

OPERATOR'S MANUAL

Generating set and industrial engines

4–16 liter (non-EDC)

Preface

Volvo Penta industrial engines are used all over the world, in both mobile and stationary applications, in all conceivable service conditions. This is not a coincidence.

After 90 years of manufacturing engines, the name Volvo Penta has come to symbolise reliability, technical innovation, first class performance and long life. We believe that this also reflects what you require and expect from your new Volvo Penta industrial engine.

In order to fully meet your expectations, we ask you to read this Instruction Book carefully before starting the engine.

Best regards

AB VOLVO PENTA



Engine data

Engine designation Product number

Serial No.

Disengageable clutch, type/no.

Local Volvo Penta service workshop

Name Tel

Address

Contents

Safety Information	2-5	Maintenance schedule	21-22
Safety Information	2	Maintenance schedule	21
Introduction	6-7	Maintenance	23-45
Responsibility for the environment	6	Engine, general	23
Running-in	6	Lubrication system	26
Fuel and oil types	6	Lubrication oils	26
Maintenance and replacement parts	6	Cooling system	29
Certified engines	7	Coolants	29
Warranty and Guarantee information	7	Fuel injection system	35
Presentation	8-11	Fuel specification	35
5-litre engines	8	Bleeding the fuel system	36-37
6 and 7-litre engines	9	Electrical system	38
10 and 12-litre engines	10	Wiring diagram	40
16-litre engines	11	Disengageable clutch	46
Identification numbers	12	Compressor	46
Engine designation	12	Shut down	47
Instrumentation	13	Storage	47
Instrument box	13	Bringing out of storage	47
Starting the engine	14-17	Fault tracing	48
Before starting the engine	14	Fault-tracing schedule	48
Starting method	14	Technical Data	49-59
Starting the engine in extremely cold conditions	16	General	49
Starting the engine using auxiliary batteries	17	Lubrication system	51
Operation	18-19	Cooling system	55
Checking instruments	18	Fuel injection system	56
Alarms and fault indications	18	Electrical system	57
Engine speed control	18	Disengageable clutches	57
Disengageable clutch	19		
Operation at low loads	19		
Stopping the engine	20		
Before stopping the engine	20		
Stopping	20		
After stopping the engine	20		
Emergency stop	20		

CALIFORNIA

Proposition 65 Warning

Diesel engine exhaust and some of its constituents are known to the State of California to cause cancer, birth defects, and other reproductive harm.

Safety Information

Read this chapter carefully. It concerns your safety. This chapter describes how safety information is presented in the Instruction Manual and on the engine itself. It also gives a general account of basic safety precautions to be taken when maintaining the engine.

Check that you have the correct Instruction Manual before you read on. If this is not the case, please contact your Volvo Penta dealer.



If operations are performed incorrectly, this could result in personal injury, or damage to property or the engine. Read the Instruction Manual carefully before operating or servicing the engine. If anything is unclear, please contact your Volvo Penta dealer for assistance.

 This symbol is used in the book and on the engine to make you aware of safety information. Always read these safety precautions very carefully.

In the Instruction Manual warning texts have the following priority:

 **WARNING!** If these instructions are not followed, there is a danger of personal injury, extensive damage to the product or serious mechanical malfunction.

 **IMPORTANT!** Used to draw your attention to something that can cause damage, product malfunction or damage to property.

NOTE! Used to draw your attention to important information that will facilitate work or operations.

 This symbol is used in certain cases on our products and refers to important information in the Instruction Manual. Ensure that warning and information symbols on the engine and transmission are always visible and legible. Replace symbols that have been damaged or painted over.

Safety precautions for operation and maintenance

Daily checklist

Make a habit of checking the engine and engine compartment visually before operating (**before the engine is started**) and after operating (**after the engine has been stopped**). This will help you to quickly detect fuel, coolant or oil leaks and spot anything else unusual that has happened or is about to happen.

Refuelling

When refuelling, there is a danger of fire and explosion. Smoking is forbidden and the engine must be switched off.

Never overfill the tank. Close the fuel tank filler cap properly.

Only use the fuel recommended in the Instruction Manual. The wrong grade of fuel can cause operating problems or cause the engine to stop. On a diesel engine, poor quality fuel may cause the fuel injection pump to seize and the engine to overrev with a resultant risk of damage to the engine and personal injury.

Carbon monoxide poisoning

Start the engine only in a well-ventilated area. If operating the engine in an enclosed space, ensure that there is proper ventilation in order to remove exhaust gases and crankcase ventilation emissions from the working area.

Operation

The engine must not be run in areas where there are explosive materials or gases. Not all electrical and mechanical components are non-sparking.

Approaching a running engine is dangerous. Loose clothing, hair, fingers or a dropped tool may catch in the rotating parts of the engine and cause serious personal injury.

Engines are supplied without guards. After the engine is installed, all rotating and hot components must be protected where necessary for reasons of personal safety.

Starting lock

If the instrument panel does not have an ignition switch, the engine compartment must be lockable to prevent unauthorised persons from starting the engine. Alternatively, a lockable main switch can be used.

Maintenance and service

Knowledge

The Instruction Manual contains instructions on how to carry out general maintenance and service operations safely and correctly. Read the instructions carefully before starting work.

Service literature covering more complicated operations is available from your Volvo Penta dealer.

Never carry out any work on the engine if you are unsure of how it should be done. Contact your Volvo Penta dealer who will be glad to offer assistance.

Stop the engine

Stop the engine before opening or removing engine hatches. Unless otherwise specified, all maintenance and service must be carried out with the engine stopped.

To prevent accidental starting, remove the ignition key, turn off the power supply to the engine at the main switches and lock them in the OFF position before starting work. Put up a warning sign in the control position that work on the engine is being carried out.

Approaching or working on an engine that is running is a safety risk. Loose clothing, hair, fingers or a dropped tool may catch in the rotating parts of the engine and cause serious personal injury. Volvo Penta recommends that all servicing with the engine running be undertaken by an authorised Volvo Penta workshop.

Safety precautions for operation and maintenance (cont.)

Lifting the engine

When lifting the engine, use the lifting eyes installed on the engine. Always check that lifting equipment is in good condition and is strong enough for the lift (engine weight plus any extra equipment). For safety's sake lift the engine using an adjustable lifting beam. All chains and cables should run parallel to each other and as perpendicular as possible in relation to the top of the engine. Bear in mind that extra equipment installed on the engine may alter its centre of gravity. Special lifting equipment may then be required in order to maintain the correct balance and make the engine safe to handle. Never carry out work on an engine suspended on a hoist.

Before starting the engine

Reinstall all guards removed during service operations before starting the engine. Check that no tools or other items have been left on the engine.

Never start a turbocharger engine without installing the air filter. The rotating compressor in the turbocharger can cause serious personal injury. Foreign objects can also be sucked in and cause mechanical damage to the unit.

Fire and explosion

Fuel and lubrication oil

All fuel, most lubricants and many chemicals are inflammable. Read and follow the instructions on the packaging.

When carrying out work on the fuel system, make sure the engine is cold. A fuel spill onto a hot surface or electrical components can cause a fire.

Store fuel-soaked rags and other flammable material so that there is no danger of them catching fire. In certain conditions oil-soaked rags can spontaneously ignite.

Do not smoke when filling fuel or oil, or in proximity of a filling station or in the engine room.

Use of components other than Volvo Original replacement parts

Components used in the fuel and electrical systems on Volvo Penta products are designed and constructed to minimise the risk of fire and explosion.

Using non-original Volvo Penta parts can result in fire or explosion.

Batteries

The batteries contain and give off oxyhydrogen gas, especially during charging. This gas is easily ignited and highly flammable.

Do not under any circumstances smoke or use naked flame or allow sparks in the vicinity of the batteries or battery compartment.

Incorrectly connecting a battery terminal cable or jump-start cable can cause a spark which in turn can cause an explosion.

Start spray

Never use start spray or similar agents to start an engine equipped with air pre-heating (glow plugs / starter element). The starter element may cause an explosion in the inlet manifold. Danger of personal injury.

Hot surfaces and fluids

There is always a risk of burns when working with a hot engine. Beware of hot surfaces. For example: the exhaust pipe, turbocharger (TC), oil pan, charge air pipe, starter element, hot coolant and hot oil in oil lines and hoses.

Chemicals

Most chemicals such as anti-freeze, rustproofing agent, inhibiting oil, degreasing agent etc. are hazardous to health. Read and follow the instructions on the packaging.

Some chemicals such as inhibiting oil are inflammable and also dangerous if inhaled. Ensure good ventilation and use a protective mask when spraying. Read and follow the instructions on the packaging.

Store chemicals and other hazardous materials out of the reach of children. To protect the environment please dispose of used or leftover chemicals at a properly designated disposal point.

Lubrication system

Hot oil can cause burns. Avoid skin contact with hot oil. Ensure that the lubrication system is not under pressure before commencing work on it. Never start or operate the engine with the oil filler cap removed, as oil can spray out.

Cooling system

Avoid opening the coolant filler cap when the engine is hot. Steam or hot coolant can spray out and cause burns.

If work must be carried out with the engine at operating temperature and the coolant filler cap or a cock open or a coolant hose disconnected, open the coolant filler cap carefully and slowly to release pressure before removing the cap completely. Note that the coolant may still be hot and can cause burns.

Fuel injection system

Always use protective gloves when tracing leaks. Liquids ejected under pressure can penetrate body tissue and cause serious injury. There is a danger of blood poisoning.

Always cover the generator if it is located under the fuel filter. The generator can be damaged by spilled fuel.

Electrical system

Cutting off power

Always stop the engine and break the current using the main switches before working on the electrical system. Isolate external power to the engine block heater, battery charger, or accessories mounted on the engine.

Batteries

The batteries contain an extremely corrosive electrolyte. Protect your skin and clothes when charging or handling batteries. Always use protective goggles and gloves.

If battery electrolyte comes into contact with unprotected skin, wash off immediately using plenty of water and soap. If battery acid comes into contact with the eyes, flush immediately with plenty of water and obtain medical assistance without delay.

Welding

Remove the positive and negative leads from the batteries. Then remove all leads to the generator.

Always connect the weld clamp to the component to be welded and as close to the welding point as possible. The clamp should never be connected to the engine or in such a manner that the current is able to pass across any bearings.

When welding is complete: Always connect the leads to the generator **before** replacing the battery leads.

Introduction

This Instruction Manual has been compiled to help you get the most from your Volvo Penta industrial engine. It contains all the information you need in order to operate and maintain your engine safely and correctly. Please read the Instruction Manual carefully and learn how to operate the engine, controls and other equipment safely.

⚠ IMPORTANT! This Instruction Manual describes engines and equipment sold by Volvo Penta. For some applications there may be variations (appearance and function) of components such as controls and instrumentation. If this is the case, see the Instruction Manual for the relevant application.

Care of the environment

We all want to live in a clean and healthy environment. Where we can breathe clean air, see healthy trees, have clean water in our lakes and oceans and enjoy the sunshine without worrying about our health. Unfortunately this is no longer something we can take for granted. We must work hard together for the environment.

As a manufacturer of engines Volvo Penta has a particular responsibility. This is why concern for the environment is one of the cornerstones of our product development. Today great advances have been made in reducing exhaust emissions, fuel consumption and engine noise in Volvo Penta's wide range of engines.

We hope that you will take care to maintain these properties. Always follow the advice in the Instruction Manual about fuel grades, operation and service and you will avoid unnecessary damage to the environment. If you notice changes such as increased fuel consumption or exhaust smoke, please contact your Volvo Penta dealer.

Always dispose of environmentally harmful waste such as engine and transmission oil, coolant, old paint, degreasing agents, cleaning residue and old batteries at proper disposal points.

Together we can work to make a valuable contribution to a clean environment.

Running-in

The engine must be "run in" for its first 10 operating hours as follows:

Operate the engine normally. Do not operate it at full load except for short periods. Never run the engine at a constant engine speed for long periods during the running-in period.

The engine can be expected to use more engine oil during the running-in period (100–200 hours) than would otherwise be normal. Check the oil level more often than is normally recommended.

Make additional checks on the disengageable clutch (if installed) for the first few days. It may be necessary to adjust it to compensate for wear to the plates.

Fuel and oil types

Only use the fuel and oils recommended in this Instruction Manual (see the chapter "Service" under the heading fuel and lubrication systems). Using other grades of fuel and oil can cause operating problems, increased fuel consumption and, in the long term, a shorter engine service life.

Always change oil, oil filters and fuel filters at the recommended intervals.

Maintenance and replacement parts

Volvo Penta engines are designed for maximum service life and reliability. They are built to survive in challenging environments, but also to cause as little environmental impact as possible. Regular servicing and the use of Volvo Penta Genuine parts will maintain these properties.

Volvo Penta have a world-wide network of authorised dealers. They are specialists in Volvo Penta products and have accessories and the original replacement parts, test equipment and special tools necessary for high quality service and repair work.

Always follow the service intervals contained in this Instruction Manual and remember to quote the engine / transmission identification number when ordering service and replacement parts.

Certified engines

If you own an engine certified for any area where exhaust emissions are regulated by law, the following is important:

Certification means that an engine type is inspected and approved by the authorities. The engine manufacturer guarantees that all engines manufactured of that type correspond to the certified engine.

This places special requirements for maintenance and service as follows:

- The maintenance and service intervals recommended by Volvo Penta must be observed.
- Only genuine Volvo Penta replacement parts may be used.
- The service of injection pumps and injectors or pump settings must always be carried out by an authorised Volvo Penta workshop.
- The engine must not be modified in any way except with accessories and service kits developed for it by Volvo Penta.

- No modifications to the exhaust pipes and air supply ducts for the engine may be undertaken.
- Seals may only be broken by authorised personnel.

In addition the general instructions contained in the Instruction Manual concerning operation, service and maintenance must be followed.

 **IMPORTANT!** Late or inadequate maintenance / service or the use of spare parts other than Volvo Penta original spare parts will invalidate AB Volvo Penta's responsibility for the engine specification being in accordance with the certified variant.

Volvo Penta accepts no responsibility or liability for any damage or costs arising due to the above.

Warranty

Your new Volvo Penta industrial engine is covered by a limited warranty according to the conditions and instructions contained in the Warranty and Service book.

Note that AB Volvo Penta's liability is limited to that contained in the Warranty and Service Book. Read this book as soon as you take delivery of the engine. It contains important information about warranty cards, service and maintenance which you, the owner, must be aware of, check and carry out. Otherwise, liability covered in the warranty may be refused by AB Volvo Penta.

Contact your Volvo Penta dealer if you have not received a Warranty and Service Book and a customer copy of the warranty card.

Presentation

The instruction book covers industrial and generator set engines from 4 to 16 liter swept volume.

The engines are four-cycle, 6-cylinder in-line diesel engines with direct diesel injection (420/520 are 4-cylinder diesel engines). The engines have replaceable wet cylinder liners (the 420 does not have liners and the 620 has dry liners), and have turbochargers. All engines have piston cooling.

The TAD engines have an air-cooled intercooler, as distinct from the TWD engines, which have a water-cooled intercooler.

The charge air cooler (CAC) reduces the temperature of the intake air. This provides the cylinders with greater volumes of air. This makes a high power output possible while keeping the combustion and exhaust gas temperatures to appropriate levels. In addition, the emission of nitrous oxides is reduced.

The engines are equipped with an electrical starter element. This facilitates starting and reduces exhaust emissions in cold weather conditions. Does not apply for engines 520/720 (COM1).

Examples of 4- and 5-litre engines

1. Charged air cooler
2. Exhaust manifold
3. Turbocharger
4. Closed crank case breather system
5. Air restriction indicator
6. Alternator
7. Starter motor
8. Flywheel housing SAE 3
9. Air filter
10. Fuel governor
11. Stop solenoid
12. Coolant heater (option)
13. Oil filling
14. Oil cooler
15. Exp. tank with filler cap
16. Engine transmission with PTO
17. Oil filter
18. Fuel filter
20. Radiator

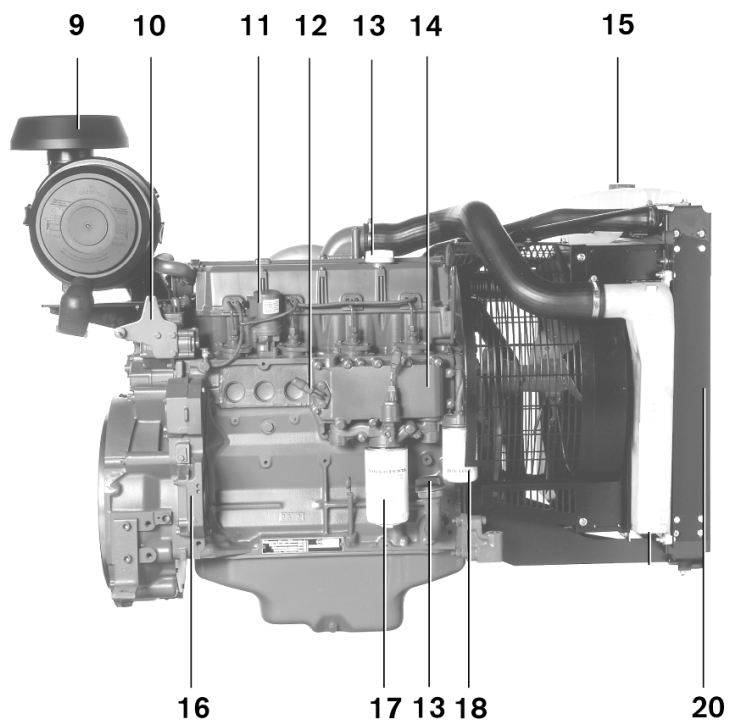
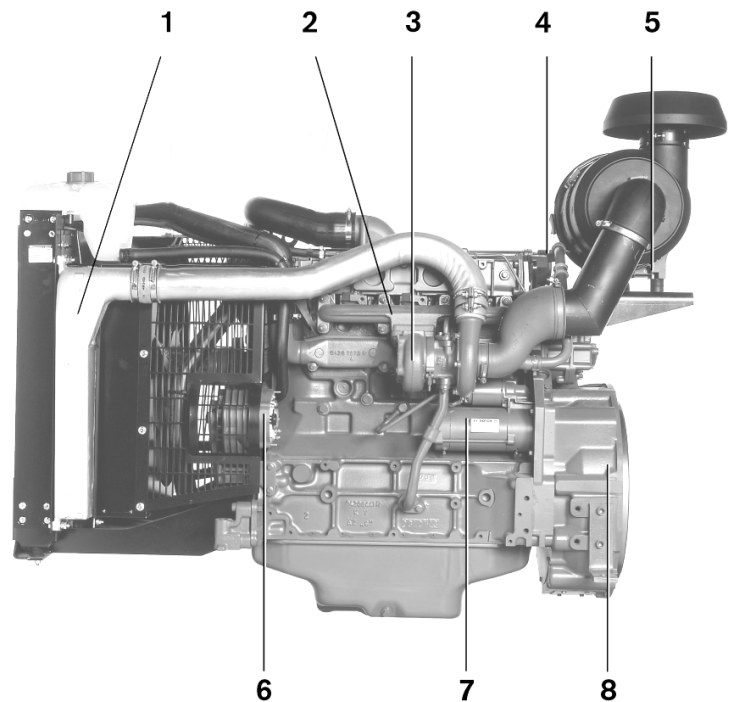

Examples of 6 and 7-litre engines

1. Fan hub
2. Gear-driven coolant pump
3. Lifting lug
4. Double fuel filter
5. Turbocharger
6. Air-cooled exhaust manifold
7. Lifting lug
8. Coolant pipe, inlet
9. Pump coupling guard
10. Smoke limiter
11. Oil cooler
12. Fuel line for tank connection
13. Injection pump
14. Muffler
15. Relay for electrical starter element
16. Electrical starter element
17. Air filter
18. Cable holder
19. Coolant pipe, outlet
20. Fan guard
21. Radiator
22. Flywheel cover
23. Instrument panel
24. Starter motor
25. Pipe for crankcase ventilation
26. Lubricating oil filter, full flow
27. Lubricating oil filter, part flow
28. Filler cap for lubricating oil
29. Vibration damper
30. Belt tensioner (automatic)
31. Frame

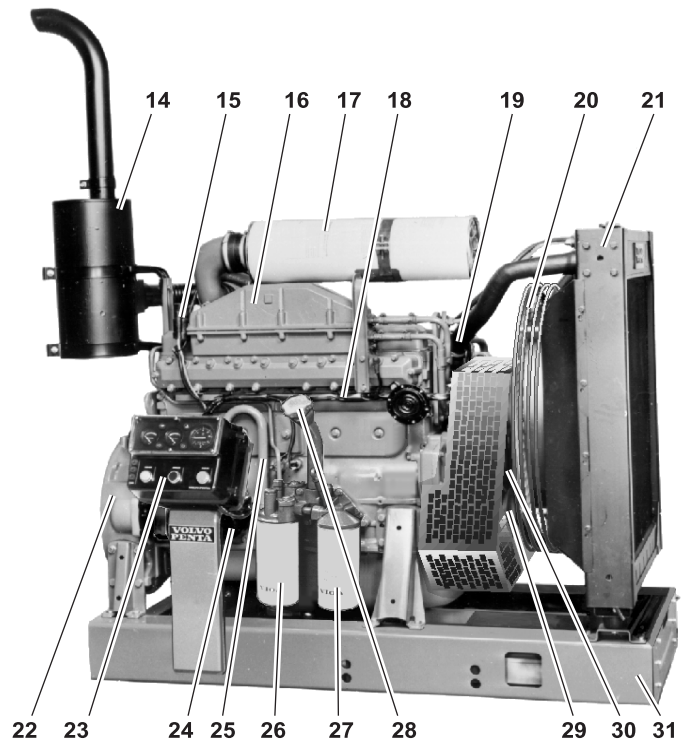
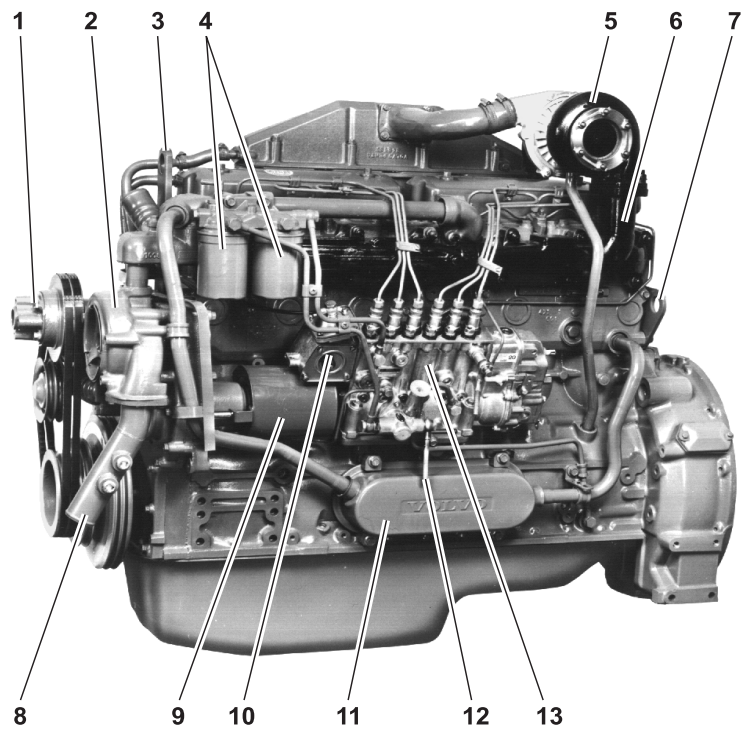

Examples of 10 and 12-litre engines

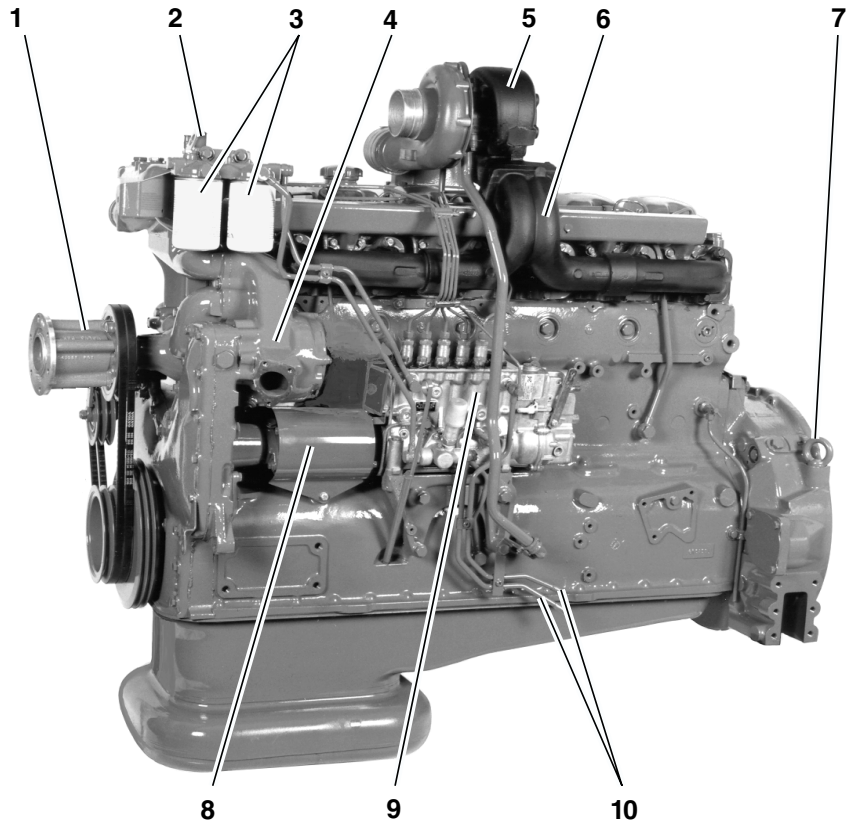

1. Fan hub
2. Lifting lug
3. Double fuel filter
4. Gear driven circulation pump
5. Turbocharger
6. Air-cooled exhaust manifold
7. Lifting lug
8. Pump coupling guard
9. Injection pump
10. Fuel line for tank connection
11. Muffler
12. Double air filters
13. Relay for electrical starter element
14. Electrical starter element
15. Cable holder
16. Coolant pipe, outlet
17. Radiator
18. Flywheel cover
19. Engine speed control
20. Instrument panel
21. Starter motor
22. Pipe for crankcase ventilation
23. Double lubricating oil filter, full flow
24. Oil cooler
25. Vibration damper
26. Belt tensioner (automatic)
27. Frame

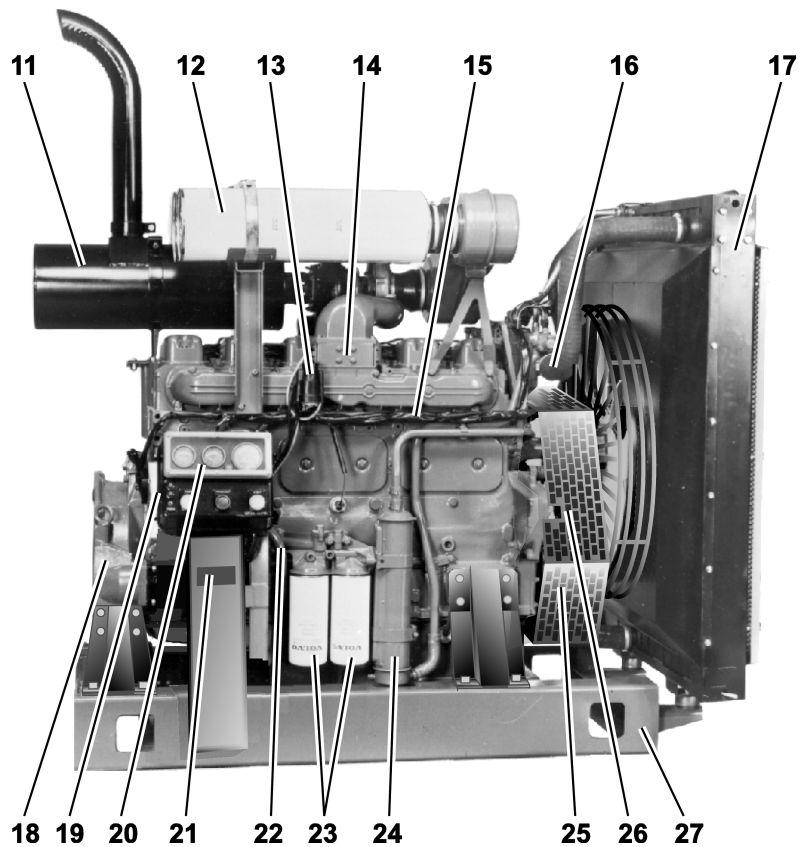

Examples of 16-litre engines

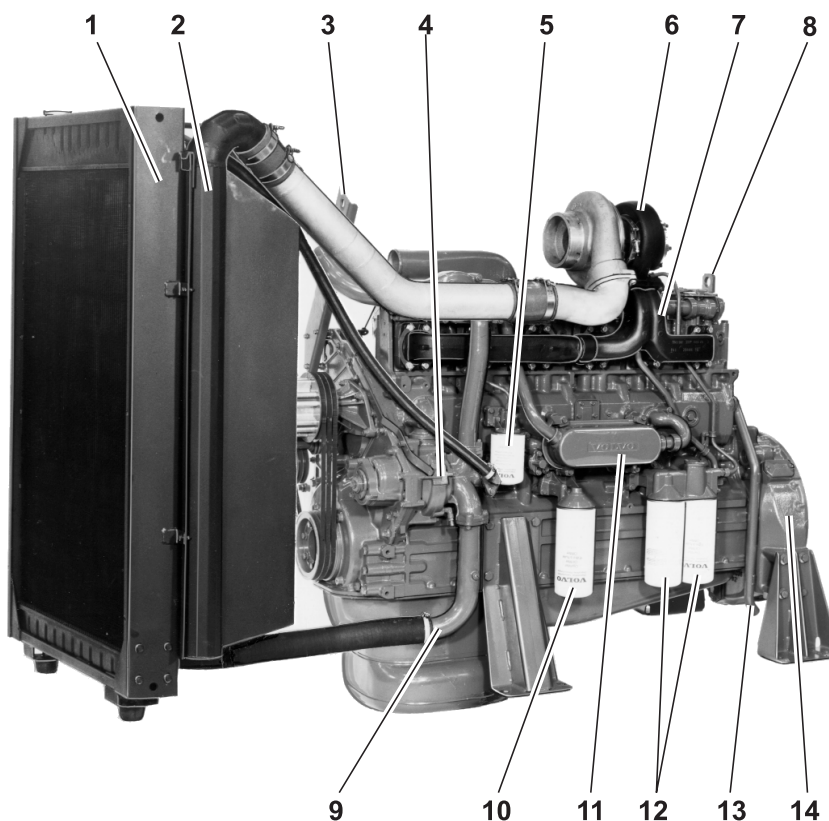

1. Radiator
2. Charge air cooler (CAC)
3. Bracket for radiator
4. Gear-driven coolant pump
5. Coolant filter
6. Turbocharger
7. Air-cooled exhaust manifold
8. Lifting lug
9. Coolant pipe, inlet
10. Lubricating oil filter, part flow
11. Oil cooler
12. Double lubricating oil filter, full flow
13. Pipe for crankcase ventilation
14. Flywheel cover
15. Muffler
16. Air filter
17. Cable holder
18. Electrical starter element
19. Relay for electrical starter element
20. Double fuel filter
21. Pressure drop indicator for air filter
22. Coolant pipe, outlet
23. Fan guard
24. Instrument panel
25. Starter motor
26. Stop solenoid
27. Engine speed control
28. Fuel line for tank connection
29. Injection pump
30. Pump coupling guard
31. Oil filler
32. Belt tensioner (automatic)
33. Frame

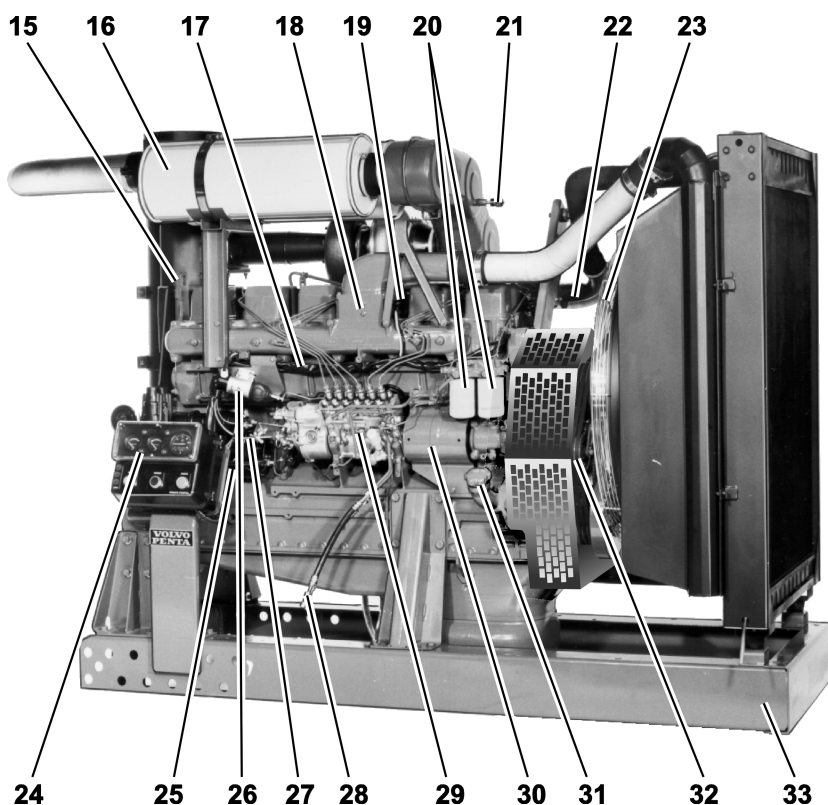

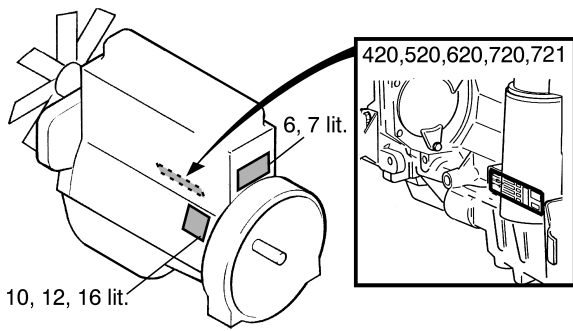

Identification numbers

The engines are supplied with two engine identification plates. One of these is supplied uninstalled so that it can be mounted in a suitable site close to the engine. The other plate is riveted to the cylinder block (see illustration).

The engine identification plate contains the serial number and engine designation. This information should always be used as a reference when ordering a service and replacement parts and when contacting your Volvo Penta workshop.

1	VOLVO PENTA	
2	ENGINE MODEL	XXXXXXXX
	SPEC. NO.	XXXXXX
3	SERIAL NO.	XXXXXXXXXX
4	RATED NET POWER without fan kW/hp	XXX/XXX
	with fan kW/hp	XXX/XXX
5	SPEED AT RATED POWER rpm	XXXX
6	PRELIFT mm/INJ. TIMING	X,X+X,X/XX±X,X°
7	MADE IN SWEDEN 3826077	

1. Engine designation
2. Product number
3. Serial No.
4. Rated gross power (without fan)
5. Rated net power (with fan), T(A)D420–721:Empty
6. Maximum engine speed (RPM)
7. Prelift/injection timing

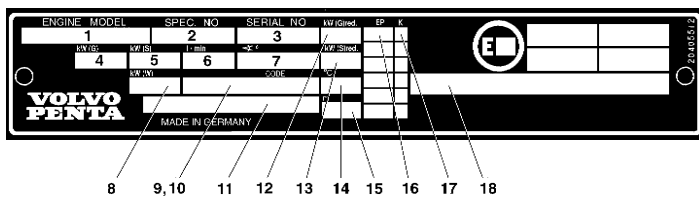

Identification plates: TD/TAD420–721

8. Empty
- 9, 10. Manufacturer identification code
11. Indication of standard and/or regulation
12. Reduced "gross power", on-site conditions, items 14, 15
13. Reduced "continuous power", on-site conditions items 14, 15
14. Air temperature in °C. For the ambient conditions on site (but standard is 25°C)
15. Altitude above sea level in m. For the ambient conditions on site (but standard is 100 m)
16. Injection pump code
17. Piston class
18. kw (PRP), power

Engine designation

The following information can be read from the engine designation:

- T** = Turbocharged
- A** = Air-to-air charge air cooler (CAC)
- W** = Water-to-air charge air cooler (CAC)
- D** = Diesel engine
- 10** = Cylinder displacement, litres
- 3** = Generation
- 1** = Version
- V** = Engine for stationary and mobile application
- G** = Generating set engine
- E** = Emission certified engine

Instrumentation

This chapter describes the instrument box and the instrumentation in Volvo Penta's range. Variations in the appearance of instrumentation may occur in certain applications (mobile for example). If this is the case, see the Instruction Manual for the relevant application.

⚠ WARNING! If the instrument box does not have an ignition switch, the engine / operator compartment must have a lock to prevent unauthorised persons starting the engine. (Alternatively a lockable main switch can be used.)

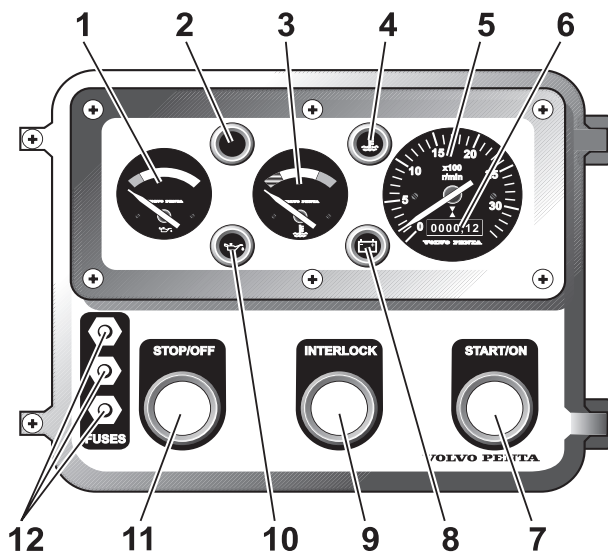

Instrument box

1. Oil pressure gauge. Normally within the green field (300–500 kPa).
2. Warning lamp: Low engine coolant level (accessory)
3. Engine coolant temperature gauge. Normally within the green field (70–95°C).
4. Warning lamp: High engine coolant temperature (accessory)
5. Tachometer
6. Operating hour counter
7. Starter button
8. Warning lamp: Generator not charging
9. Interlock: Press in the button to disengage the automatic stop for low oil pressure and to activate preheating.
10. Warning lamp: Low oil pressure (accessory)
11. Stop button
12. Semi-automatic fuses: Reset by pressing the button on the fuse

Starting the engine

Make a habit of checking the engine and engine compartment before starting the engine. This will help you to quickly detect anything unusual that has happened or is about to happen. Check that the instrument readings are normal after starting the engine.

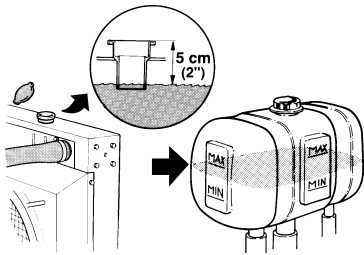
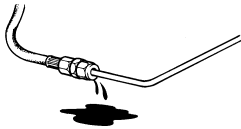
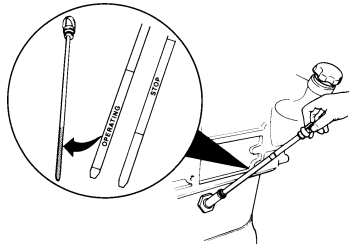

Before starting the engine

- Check that the oil level is between the MIN and MAX marks. See chapter “Maintenance, Lubrication system”.
- Open the fuel cocks
- Check that there are no coolant, fuel or oil leaks.
- Check the air filter pressure drop indicator. See chapter “Maintenance, Engine, general”.
- Check coolant level. Check that the outside of the radiator is not clogged. See chapter “Maintenance, Cooling system”.
- ⚠ **WARNING!** Do not open the engine coolant system filler cap when the engine is still hot. Steam or hot coolant may spray out.
- Switch on the main switches
- ⚠ **IMPORTANT!** Never break the circuit with the main switch while the engine is running. This could damage the generator.
- Set the engine speed control to idle. Disengage the disengageable clutch/transmission.



Starting method

⚠ WARNING! Never use start spray or similar to start the engine. The starter element may cause an explosion in the inlet manifold. There is a risk of serious personal injury.

Instrument box:

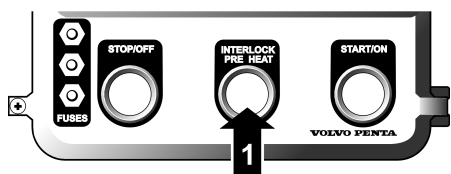
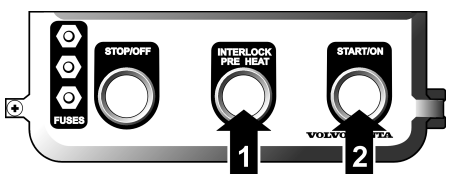
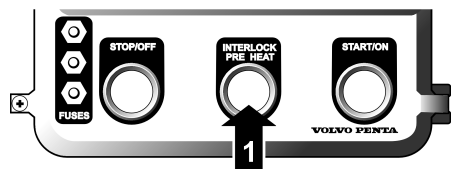

1. Press the “Interlock button” (1) and check that the warning lamps in the instrument box are functioning. (This applies to engines equipped with alarm separators).

2. **If the engine is hot:** Press the “Interlock button” (1) and hold it in while pressing the Starter button (2).

If the engine is cold: Press the Interlock button (1) and hold it in for approximately 50 seconds to preheat the engine. Then press the “Start button” (2) as well.

3. Release the Start button immediately when the engine starts.

However the Interlock button must be held down for a further 5 seconds approximately. This is to allow the oil pressure to reach the correct level. Otherwise the automatic stop will engage and stop the engine.

NOTE! In extreme cold, the preheating can be re-engaged for a few minutes after start if necessary. Hold the Interlock button (1) pressed in.

⚠ IMPORTANT! The start button must **never** be pressed in when the engine is running. The starter motor and starter gear on the flywheel may be seriously damaged.

4. Allow the engine to run at 500–700 rpm for the first 10 seconds. Then warm up the engine at low speed and low load.

⚠ IMPORTANT! Do not race the engine while it is cold.

NOTE! Generating set engines automatically rev up to the pre-set engine speed (1500 or 1800 rpm).

Volvo Penta starting lock:

1. **If the engine is hot:** Proceed directly to point 2.

If the engine is cold: Turn the ignition key to position “II” to engage the preheating. Hold the key in this position for approximately 50 seconds. (If the engine is equipped with a time relay for preheating, the key can be released. Preheating stops automatically after 50 seconds).

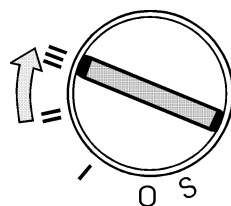
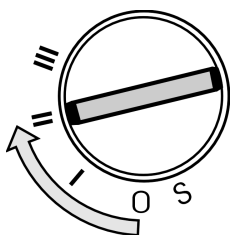

2. Turn the key to position “III”. Release the key to position “II” immediately when the engine starts. Hold the key in this position for approximately 5 seconds. This is to allow the oil pressure to reach the correct level. Otherwise the automatic stop will engage and stop the engine.

If the engine does not start, turn the key to the “O” position before trying again.

NOTE! In extreme cold, the preheating can be re-engaged for a few minutes after start if necessary. Hold the ignition key in position “II”.

3. Allow the engine to run at 500–700 rpm for the first 10 seconds. Then warm up the engine at low speed and low load.

⚠ IMPORTANT! Do not race the engine while it is cold.

NOTE! Generating set engines automatically rev up to the pre-set engine speed (1500 or 1800 rpm).

Starting the engine in extremely cold conditions

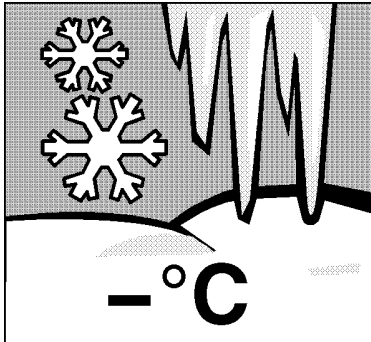

Preparations must be made to allow the engine to be started in extremely cold conditions.

Use a winter fuel (a proprietary brand) approved for the prevailing temperature. This reduces the risk of wax deposits in the fuel injection system. A fuel heater is recommended for extremely low temperatures.

Use a synthetic lubricating oil of a viscosity recommended for the prevailing temperature. See chapter "Lubrication system service". Synthetic oils can withstand greater temperature ranges than mineral-based oils.

Preheat the engine coolant with a separate electrical engine block heater. In extreme cases a diesel engine block heater may be required. Ask your Volvo Penta service dealer for advice.

⚠ IMPORTANT! Ensure that the cooling system is filled with antifreeze. See chapter "Maintenance, Cooling system".

Batteries must be in good condition. Cold reduces battery capacity. An increase in battery capacity may be necessary.

Starting the engine using auxiliary batteries

⚠ WARNING! The batteries (auxiliary batteries in particular) contain extremely explosive oxyhydrogen gas. One spark, which may be formed if the auxiliary batteries are connected incorrectly, is sufficient to cause a battery to explode and cause damage and injury.

1. Check that the auxiliary batteries are connected (in series or in parallel) so that their rated voltage is the same as the engine's system voltage.
2. First connect the red jump lead (+) to the auxiliary battery, then to the discharged battery. Then connect the black jump lead (-) to the auxiliary battery, then to a **spot a short distance from the discharged batteries**, for example at the main switch on the negative cable or at the negative cable's connection to the starter motor.
3. Start the engine.

⚠ WARNING! Do not shift the connections when attempting to start the engine (spark risk) and do not lean over any of the batteries.

4. Remove the jump leads in exactly the opposite order to which you connected them.

⚠ WARNING! Do not under any circumstances move the normal leads to the standard batteries.

Operation

Correct operation is the key to fuel economy and engine service life. Always allow the engine to achieve normal operating temperature before running it at full power. Avoid opening the throttle too quickly and running the engine at high engine speeds.

⚠ IMPORTANT! An automatic shut-off for oil pressure and engine coolant temperature (ECT) must be installed during unattended operation where the Volvo Penta instrument box is **not** being used.

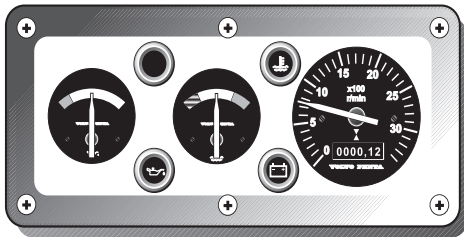

Checking instruments

Check the instruments directly after starting the engine and then at regular intervals while operating the engine. The needles should be within the green range.

Engine coolant temperature: 75–95°C (167–203°F)

420, 620 VE: 83–95°C (181–203°F)

520, 720 GE: 83–95°C (181–203°F)

520, 720, 721 VE: 87–102°C (189–216°F)

Oil pressure, engine at operating temperature: 300–500 kPa. At engine idle this is normally lower.

⚠ IMPORTANT! The lubricating oil level must be checked at least every eight hours if the engine is running continuously. See chapter “Maintenance, Lubricating system”.

Alarms and fault indications

If the Volvo Penta instrument box is used, the following applies:

- If oil pressure is too low or engine coolant temperature (ECT) too high, the engine stops automatically and the acoustic alarm goes off.
If the engine is equipped with an alarm separator, the relevant warning lamp also lights.
- If the engine coolant level is too low and the engine is equipped with an engine coolant level switch, the engine stops automatically and the acoustic alarm goes off. The warning lamp lights.
- If generator charging drops, the warning lamp lights.

For other applications see the Instruction Manual for the relevant application.

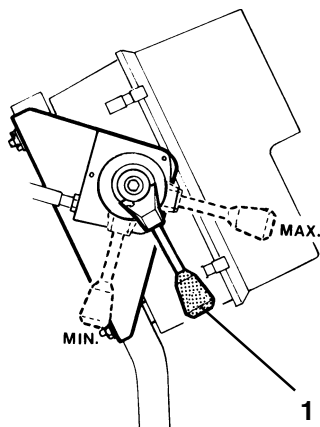
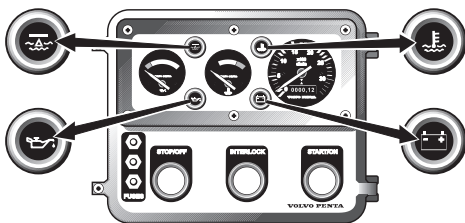

Engine speed control

Power pack: The engine speed (RPM) is adjusted using the mechanical engine speed control (1). This is mounted on the instrument box.

Other engines: See the relevant instruction manual.

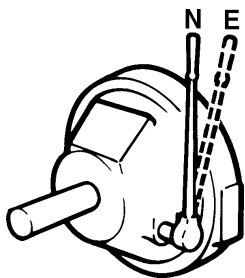

Disengageable clutch

The clutch is disengaged when the control lever is in position “N” and engaged when the lever is in position “E”.

⚠ IMPORTANT! The engine speed must not exceed 1000–1200 rpm during engagement and disengagement.

Operation at low loads

Avoid running the engine at idling speed or low loads for long periods. This can cause increased oil consumption and oil leakage from the exhaust manifold. (Oil passes the turbocharger seals and is drawn into the intake manifold with the charge air when turbocharger pressure is low.)

This leads to soot deposits on valves, piston crowns, exhaust outlets and the exhaust turbine.

At low loads the temperature of combustion is so low that fuel is not burnt up properly. This can lead to contamination of the lubricating oil with fuel and eventually leakage from the exhaust manifold.

In addition to normal inspections follow the points below to avoid operating problems caused by running the engine at low loads.

- Operate the engine at low loads as little as possible. (If the engine is tested without load each week, limit running time to approximately five minutes).
- Operate the engine at full load for approximately four hours once a year. This will burn off soot deposits in the engine and exhaust system.

Stopping the engine

In the case of extended inactivity, the engine must be run to operating temperature at least once every 14 days. This prevents corrosion in the engine. If the engine will not be used for more than two months, inhibiting should be carried out: Refer to chapter “Shut down”.

⚠ IMPORTANT! If there is a risk of frost, the cooling system coolant must have sufficient antifreeze. See chapter “Maintenance, Cooling system”. A poorly charged battery may burst as a result of freezing.



Before stopping the engine

Let the engine run without load at 1300–1500 rpm for a few minutes before stopping. This will even out the engine temperature and prevent overheating.

⚠ IMPORTANT! This is especially important if the engine has been operated at high engine speeds and/or loads.

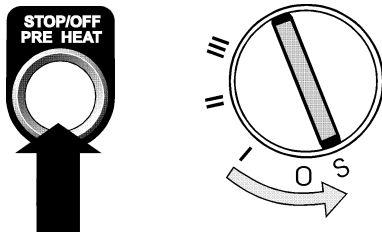

Stopping

- Disengage the engine (if possible).
- Press in the stop button and hold it depressed until the engine has stopped. Alternatively, turn the key to stop position “S”. Release the key when the engine has stopped.

After stopping the engine

- Inspect the engine and engine compartment for any leaks.
- Close the fuel cocks.
- Switch off the main switch if the engine will not be used for some time.
- Read off the operating hour counter. Carry out the required service according to the maintenance schedule.

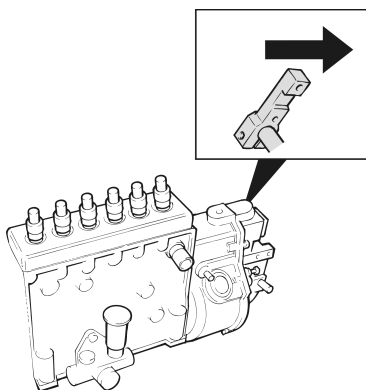
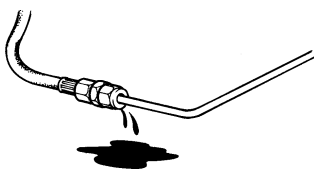

Emergency stop

If the engine cannot be stopped normally, it can be stopped by moving the lever on the fuel injection pump backwards.

⚠ WARNING! Approaching or working on a running engine is dangerous. Watch out for rotating components and hot surfaces.

Maintenance schedule

To achieve maximum operating safety and service life, it is vital that the engine is regularly serviced. By following the service recommendations, engine quality is retained and unnecessary environmental damage avoided.

 **WARNING!** Read the chapter on “Maintenance” carefully before starting service work. It contains instructions on how to carry out the work safely and correctly.

 **IMPORTANT!** Service operations marked must be carried out by an authorised Volvo Penta Service workshop.

DAILY BEFORE STARTING FOR FIRST TIME

- Engine oil. Level checks ¹⁾ page 27
- Coolant. Level checks page 31
- Radiator. External check and cleaning page 34
- Air filter indicator. Check ^{1, 2, 3)} page 23
- Leakage check. Engine not shown

¹⁾ When in continuous use the oil level should be checked every 8 hours.

²⁾ The air filter should be replaced when the gauge remains in the red field after the engine has been stopped.

³⁾ When operating in extremely dirty conditions special air filters must be used.

AFTER THE FIRST 100–200 OPERATING HOURS ¹⁾

- Valve clearance. Check not shown
- Injectors. Post tightening (50 Nm) not shown

¹⁾ 300 operational hours apply for TAD / TWD 1630 and 1631.

EVERY 50 HOURS

- Fuel pre-filter. Drain water page 36
- Battery. Check electrolyte level page 39
- Disengagement bearing. Lubricating ¹⁾ page 46

¹⁾ Applies to disengageable clutch when clutch operations exceed 15–20 operations per day. Otherwise every 400 hours.

EVERY 6 MONTHS

- Coolant filter. Replace ¹⁾ page 34

¹⁾ The filter should not be changed when replacing coolant.

EVERY 50-600 HOURS OR AT LEAST EVERY 12 MONTHS

- Engine oil and oil filter. Replace ¹⁾ page 28
- Disengageable clutch. Lubrication ²⁾ page 46
- Disengageable clutch. Adjustment ²⁾ page 46

¹⁾ Variable replacement intervals depending on oil quality and fuel sulphur content.

²⁾ Every 200 hour.

EVERY 400 HOURS (420–720, EVERY 500 HOURS)

- Drive belts. Checking and adjusting not shown
- Fuel tank (sludge collector). Drain not shown

EVERY 800 HOURS (420–720, EVERY 1000 HOURS)

- Fuel filter. Replace page 35
- Fuel pre-filter. Replace page 36
- Air lines. Leakage check. page 23

EVERY 1200 HOURS (420–720, EVERY 1500 HOURS)

- Valve clearance. Adjustment not shown

EVERY 2000 HOURS OR AT LEAST EVERY 12 MONTHS

- Air filter for air compressor. Replace not shown
- Charge air cooler. Cleaning (TAD-engines) ²⁾ page 34

EVERY 2400 HOURS

- Injectors. Check ³⁾ not shown
- Turbocharger. Check not shown
- Engine and equipment. General check not shown

EVERY 5000 HOURS OR AT LEAST EVERY TWO YEARS

- Coolant. Replace ¹⁾ page 31–34

¹⁾ If the engine is equipped with coolant filters, extended intervals apply between replacement.

²⁾ When operating in extremely dirty conditions, must cleaning be carried out often.

³⁾ 420–721 Every 3000 hours.

Maintenance

This chapter describes how to carry out the above maintenance. Read the instructions carefully before starting work. Maintenance intervals are contained in the chapter above. Maintenance schedule

⚠ WARNING! Read the safety precautions for maintenance and service in the chapter: Safety Information, before starting work.

⚠ WARNING! Unless otherwise specified all maintenance and service must be carried out with the engine stopped. Immobilise the engine by removing the ignition key, turning off the power supply with the main switch. Approaching or working on a running engine is dangerous. Watch out for rotating components and hot surfaces.

Engine, general

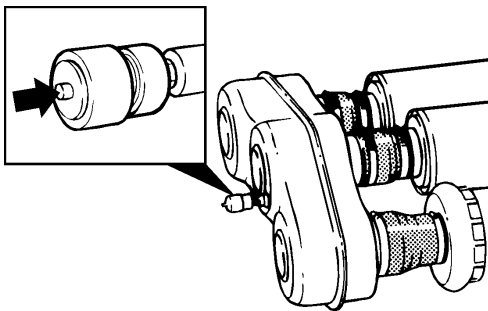

Air filter. Check / replace.

The air filter should be replaced when the indicator remains in the red field when the engine has stopped. Reset the gauge after replacing the indicator by pressing the button.

NOTE! The filter should not be touched until the indicator displays the red field. Scrap the old filter. Do not clean or reuse.

⚠ IMPORTANT! In continuous use the air cleaner should be checked every 8 hours.

When running in extremely dirty environments, coal mines and quarries for example, special air cleaners are required (not available from Volvo Penta).

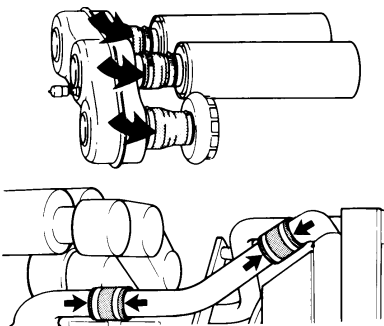

Air lines. Leakage check.

Check the air lines for cracks or other damage. Replace if required. Checking all hose clamps.

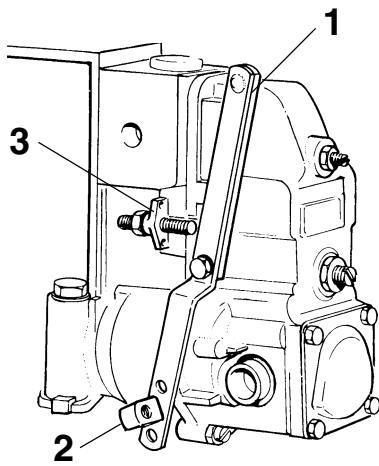

Idling speed. Adjustment

First check that the air filter is not clogged and that the throttle arm (1) on the fuel injection pump is against the idling speed stop (2) when the throttle mechanism is in idling position. Check also that the throttle arm presses against the max stop (3) when the throttle control is in the wide open throttle (WOT) position. Adjust the control if necessary.

Idling speed must only be checked and adjusted when the engine has reached normal operating temperature. For the correct idling speed, see the “Technical data” chapter.

⚠ WARNING! Approaching or working on a running engine is dangerous. Watch out for rotating components and hot surfaces.

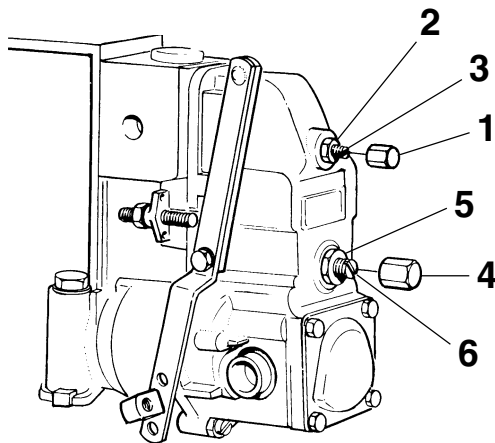

RSV governor

1. Allow the engine to operate at low idling speed.
2. If necessary, adjust the engine speed by removing the domed nut (1), slackening off the locknut (2) and adjusting the engine speed with the screw (3).

If the engine speed is uneven, the idle speed damping should be adjusted as follows:

1. Remove the domed nut (4) and slacken off the locknut (5). Carefully turn the damping screw (6) clockwise until the engine speed stabilises.
2. Check that the high idling speed has not changed. If it has changed, the damping screw (6) has been screwed in too far.
3. Lock the damping screw (6) and install the domed nut (4) when the adjustment is complete.

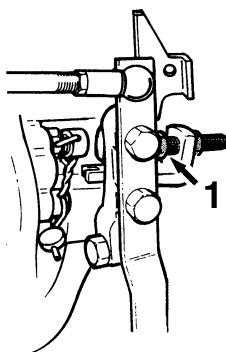

RQV, RQ governor

1. Allow the engine to operate at low idling speed.
2. If necessary, adjust the engine speed with the screw for low idling speed (1).

GAC governor

To adjust the idling speed on Generating set engines with GAC governor, refer to the separate documentation supplied with the GAC equipment.

Governor (Heinzmann)

The governors of the T(A)D 420–721 GE series engines are mechanical variable-speed governors with centrifugal measuring element of M/s Heinzmann.

All governor settings may only be conducted by trained specialists on a specifically laid out governor test bench.

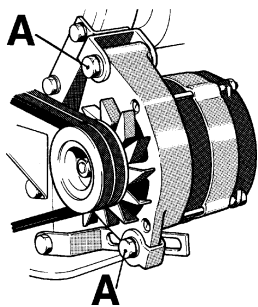

Drive belts. Checking and adjusting

Inspection and adjustment should be carried out after running the engine when the belts are warm.

Undo the screws (A) before tensioning the generator belts. It should be possible to depress the belts 10 mm between the pulleys. Worn belts which work in pairs should be replaced at the same time.

The fan belts have an automatic belt tensioner and do not need adjusting. However, the condition of the belts must be checked. Replace if required.

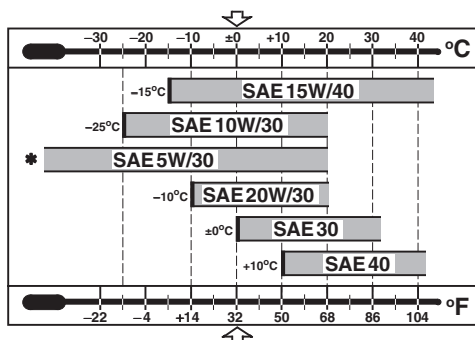

Viscosity

In a stable outside temperature viscosity should be selected from the table alongside.

*Refers to synthetic or semi-synthetic oil.

Oil change volumes

See chapter "Technical Data".

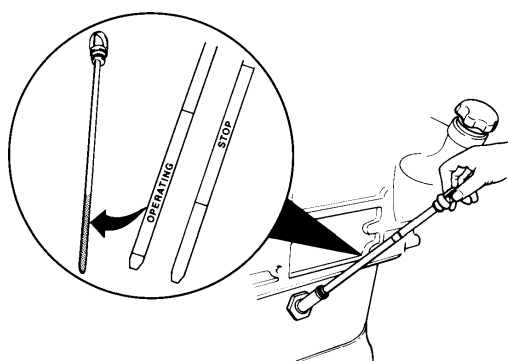

Oil level. Check

Ensure that the level lies between MIN and MAX markings.

⚠ IMPORTANT! In continuous use the oil level should be checked every 8 hours.

When checking the oil level on a stationary engine, read off the side of the dip stick marked "STOP" (**at earliest 3 minutes after engine stop**).

A check can also be carried out when the engine is running. Read off the dip stick side marked "OPERATING". (Does not apply for engines: TAD/TWD740GE, TD/TAD420-721, TAD1030GE)

⚠ WARNING! Approaching or working on a running engine is dangerous. Watch out for rotating components and hot surfaces.

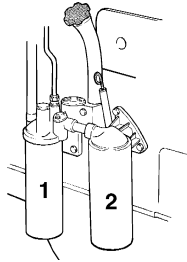
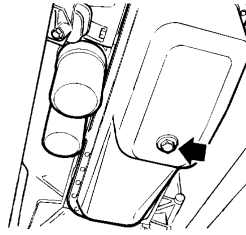
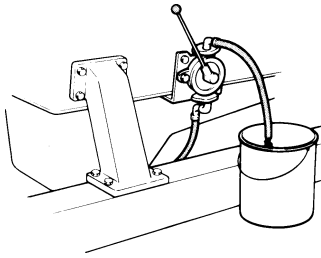

6, 7 lit.

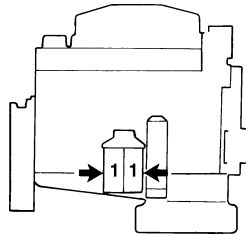

10, 12 lit.

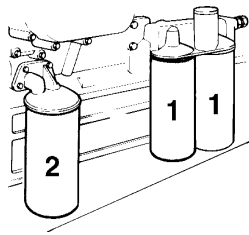

16 lit.

Oil and oil filters. Replace

Always follow the recommended oil change interval and always replace the oil filter at the same time. On stationary engines do **not** remove the bottom plug. Use an oil draining pump to suck up the oil.

1. Clean the oil filter bracket thoroughly to avoid dirt ingress when the new filter/s are installed.
2. Run engine to normal operating temperature.

⚠ WARNING! Hot oil and hot surfaces can cause burns.

3. Remove the bottom plug. Drain out engine oil.
4. Install the bottom plug together with a new gasket.
5. Remove the filters (1) and the bypass filter (2).where applicable. Check that the gaskets do not remain on the engine.
5. Fill the new filters with engine oil and spread oil on the gaskets. Screw the filter into place by hand until the gasket touches. Then twist a further half turn. **No more!**
6. Top up oil to correct level. **Do not fill above the MAX level.**
7. Start the engine and let it idle. Check that the oil pressure is normal.
8. Stop the engine. Check that there is no oil leakage around the filter. Top up if required.

Collect the old oil and oil filter and dispose of them at a proper disposal point.

Cooling system

The cooling system ensures that the engine operates at the correct temperature. It is a closed circuit system and must always be filled with a mixture of at least 40 % concentrated coolant and 60 % water to protect against internal corrosion, cavitation and damage caused by freezing.

We recommend that you use “**Volvo Penta Coolant, Ready Mixed**”, alternatively “**Volvo Penta Coolant**” (concentrated) mixed with **pure** water according to spec, see “Coolant. Mixture”. Only coolant of this quality is suited too and approved by Volvo Penta.

The coolant should contain ethylene glycol of a good quality with a suitable chemical consistency for an adequate protection of the engine. Using anti-corrosion additive exclusively is not permitted in Volvo Penta’s engines. Never use water by itself as coolant.

⚠ IMPORTANT! Coolant, with suitable consistency, must be used all year round. This applies even if there is never any risk for frost , to ensure that the engine has an adequate protection against corrosion. Future warranty claims on the engine and additional equipment may be rejected if an unsuitable coolant has been used or if the instructions concerning coolant mixing have not been followed.

NOTE: The anti-corrosive agents become less effective after a time, which means that the coolant must be replaced, see “Service schematic”. The cooling system should be flushed out at the same time as the coolant is replaced, see “Cooling system. Flushing”.

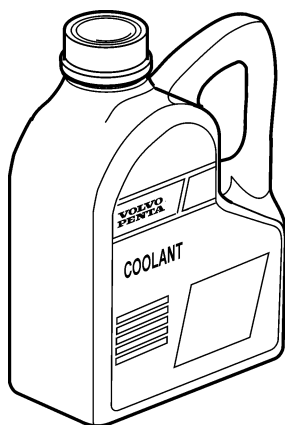

“**Volvo Penta Coolant**” is a concentrated coolant that is to be mixed with water. It has been developed to function optimally with Volvo Penta’s engines and provides excellent protection against corrosion, cavitation and frost damage.

“**Volvo Penta Coolant, Ready Mixed**” is a ready-mixed coolant, 40% “Volvo Penta Coolant” and 60% water. This concentration protects the engine against corrosion, cavitation damage and freezing conditions down to -28 °C (18°F).

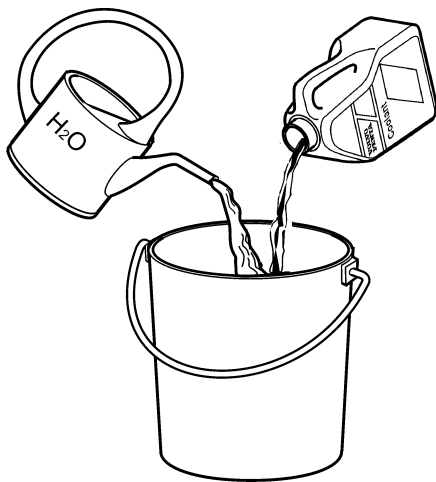

Coolant. Mixture

⚠ WARNING! All glycol is hazardous and harmful to the environment. Do not consume!
Glycol is flammable.

⚠ IMPORTANT! Ethylene glycol must not be mixed with other types of glycol.

Mix:

**40 % “Volvo Penta Coolant” (conc. coolant)
60 % water**

This mixture protects the engine against internal corrosion, cavitation and frost damage down to $-28\text{ }^{\circ}\text{C}$ (18°F). (Using 60 % glycol lowers the freezing point to $-54\text{ }^{\circ}\text{C}$ (65°F)). Never mix more than 60 % concentrate (Volvo Penta Coolant) in the cooling liquid, this will give reduced cooling effect and increase the risk of overheating, and will give reduced freezing protection.

⚠ IMPORTANT! Coolant must be mixed with **pure** water, use **distilled - de-ionized water**. The water must fulfill the requirements specified by Volvo Penta, see “Water quality”.

⚠ IMPORTANT! It is extremely important that the correct concentration of coolant is added to the system. Mix in a separate, clean vessel before adding into the cooling system. Ensure that the liquids mix properly.



Water quality

ASTM D4985:

Total solid particles	< 340 ppm
Total hardness:	< 9.5° dH
Chloride	< 40 ppm
Sulfate	< 100 ppm
pH value	5,5–9
Silica (acc. ASTM D859)	< 20 mg SiO ₂ /l
Iron (acc. ASTM D1068)	< 0.10 ppm
Manganese (acc. ASTM D858)	< 0.05 ppm
Conductivity (acc. ASTM D1125)	< 500 μS/cm
Organic content, COD _{Mn} (acc. ISO8467)	< 15 mg KMnO ₄ /l

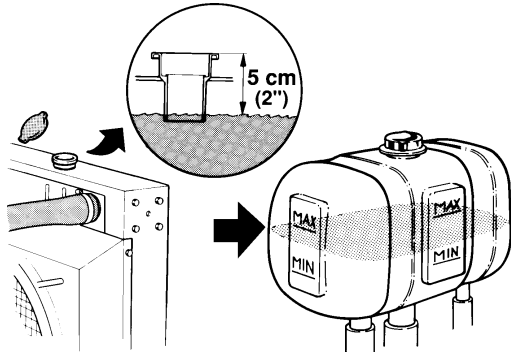

Coolant. Checking and topping up

⚠ WARNING! Except in an emergency, do not open the engine coolant system filler cap when the engine is still hot. Steam or hot coolant may spray out.

Check the coolant level daily before starting. Top up coolant if necessary. Fill to 5 cm below the filler cap sealing surface or between the MIN and MAX markings if a separate expansion tank is installed.

⚠ IMPORTANT! When topping up, use the same coolant mixture as is already in the cooling system.

Filling an empty system

Check that all the drain cocks are closed. Opening the bleed cock(s). 4–7 litre engines are self-airing. Therefore they have no bleed cock.

The locations of the drain and bleed cocks are displayed on the next page.

The engine must be stopped when filling. Fill slowly so that air is able to stream out through the bleed cock(s) and the filler opening.

If a heater system is connected to the engine's cooling system, the heater control valve must be opened and the unit vented during filling.

Fill with coolant to the correct level. **The engine must not be started until the system has been vented and completely filled.**

Start the engine and run it until the thermostat opens (this takes approximately 20 minutes). After start, open any bleed cocks briefly. This releases any trapped air. Check the coolant level and top up if necessary.

Coolant. Draining

Before draining the coolant, the engine must be stopped and the filler cap unscrewed.

⚠ WARNING! Except in an emergency, do not open the engine coolant system filler cap when the engine is still hot. Steam or hot coolant may spray out.

Open the drain cocks and remove the drain plugs (location is shown below). Unscrew and remove the coolant filter if one is installed.

⚠ IMPORTANT! There may be deposits inside the cocks/plugs. These must be removed. Check that all the coolant has drained out.

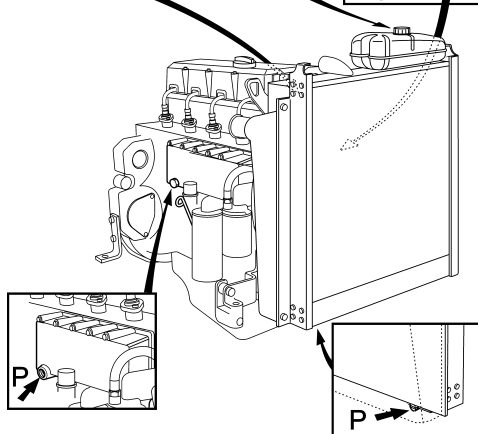
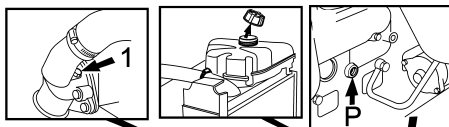
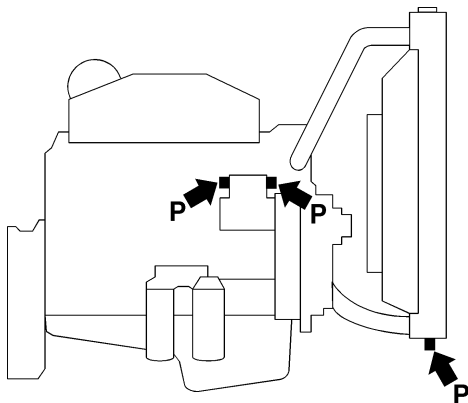
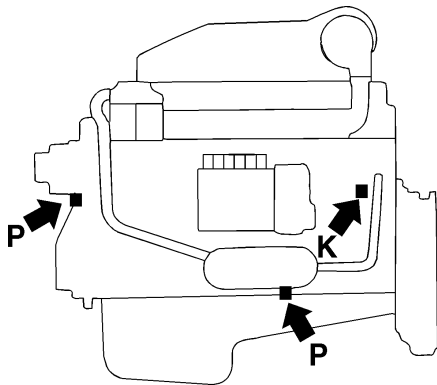

TD/TAD420–721

Drain/bleed cocks. Location

4–7 litre engines

Drain cock (K):

- on the left-hand side of the cylinder block, rear section (Does not apply for engine 420–721.)

Drain plugs (P):

- under the radiator
- beside cyl. 3 (TD/TAD420–721)
- under the coolant pump (Does not apply for 420–721)
- under the oil cooler
- 2 (at front and rear) on the air compressor, if installed (accessory) (Does not apply for 420–721)
- remove bottom radiator hose (Does not apply for 420–721)

Bleed cock (1):

- The engines are self-airing. Therefore they have no vent cock. (Does not apply for 420–721)
- On the coolant pump (TD/TAD420–721)

10–12 litre engines

Drain cocks (K):

- at the rear of the left-hand side of the cylinder block
- charge air cooler, front (only TWD)

Drain plugs (P):

- under the radiator
- under the oil cooler
- 2 (at front and rear) on the air compressor, if installed (accessory)

Bleed cock (V):

- charge air cooler, rear (only TWD)

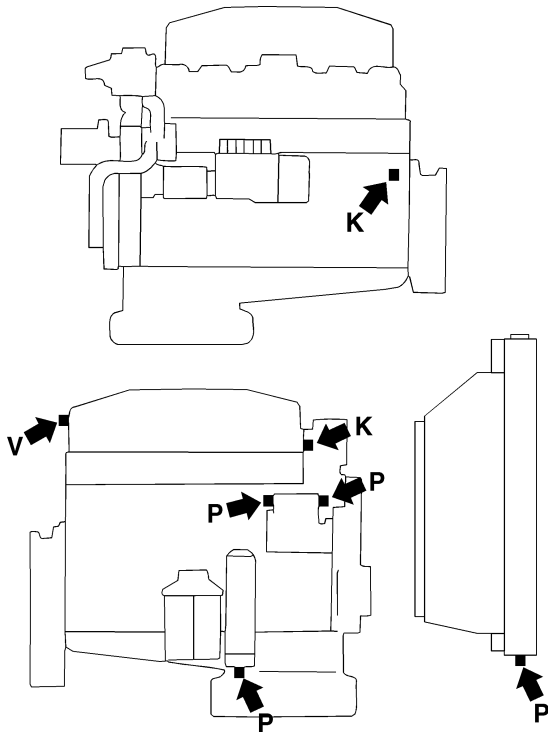

16 litre engines

Drain cocks (K):

- on the cylinder block above the starter motor
- under the rear edge of the coolant pump
- Charge air cooler, front end (only TWD)

Drain plugs (P):

- under the radiator
- under the oil cooler
- 2 (at front and rear) on the air compressor, if installed

Coolant filter:

- behind the coolant pump

Bleed cock (V):

- TWD1630: Charge air cooler, at front
- TWD1630, TAD1630/1631: Radiator hose connection
- TAD1630/1631: Thermostat housing

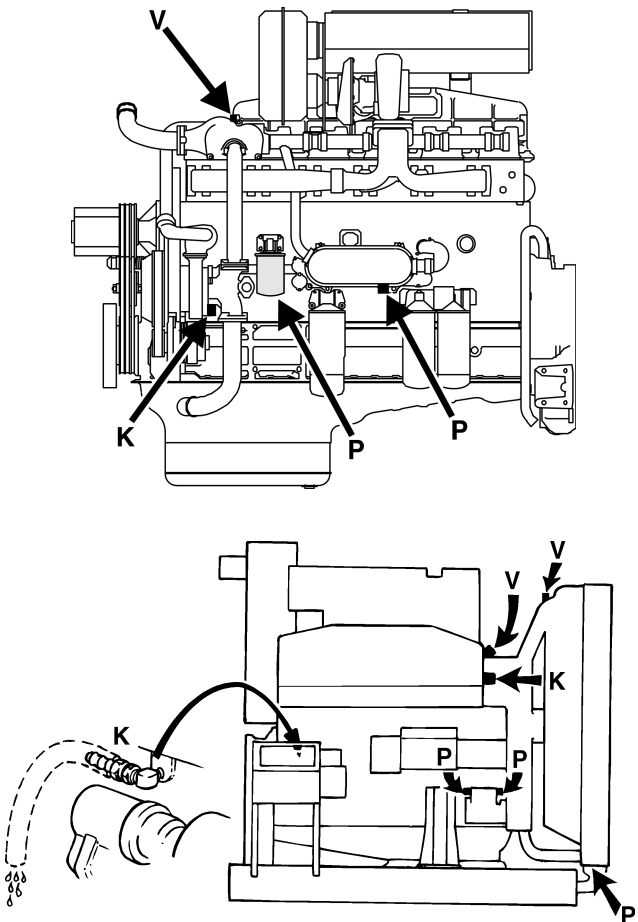

Cooling system. Flushing

Cooling performance is reduced by deposits in the radiator and cooling channels. The cooling system must therefore be flushed through when the coolant is replaced.

1. Drain the coolant as above.
2. Insert a hose in the radiator filler opening and rinse out with freshwater until the water which runs out is completely clear.
3. Close the drain cock and plugs. Fill with new coolant according to the instructions in the section "Coolant. Checking and topping up"

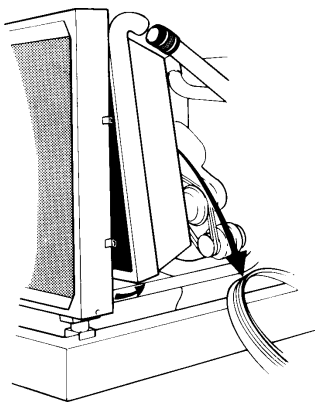

Cooler (charge air cooler TAD). External cleaning

Remove the required guards to access the radiator. Clean with water and a mild cleaning agent. Use a soft brush. Take care not to damage the cooling vanes. Reinstall components

⚠ IMPORTANT! Do not use a high pressure hose.

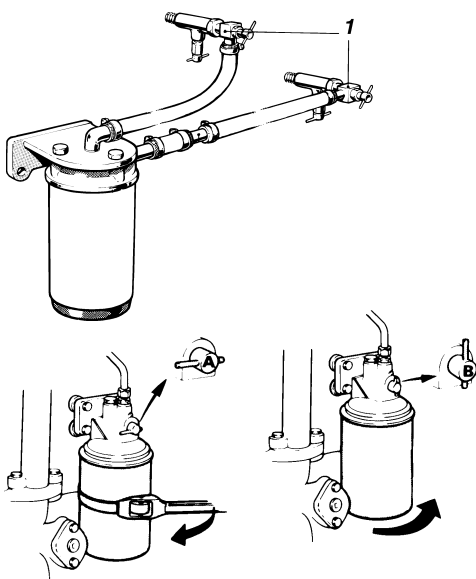

Coolant filter. Replace

The coolant filter is only standard on 16-litre engines. For other engines, it is available as an optional extra. It has the task of filtering the coolant and providing anti-corrosion protection.

⚠ IMPORTANT! To prevent overdoses of anti-corrosion protection subsequently causing a blockage, the filter should **not** be replaced at the same time as the coolant, but 6 months after the first coolant replacement and then every 6 months.

Close the cocks (1) or turn the cock to position "A" (16-litre). Remove the filter with a suitable filter puller. Dampen the gasket and screw on new filter by hand. Tighten by 1/2 turn once the gasket is tight. Open the cocks (1) or turn the cock to position "B" (16-litre).

Fuel injection system

Only use recommended quality fuels according to the specifications below. Always observe strict cleanliness when refuelling and working on the fuel injection system.

All work on the engine injection pump or injectors must be carried out at an authorised workshop. **If the injection pump lead seal is broken, all warranties are invalid.**

⚠ WARNING! Fire risk. When carrying out work on the fuel system, make sure the engine is cold. A fuel spill onto a hot surface or an electrical component can cause a fire. Store fuel-soaked rags so that they cannot cause a fire.

Fuel specification

Fuel must meet national and international standards for marketed fuel, for example:

EN590 (with national environmental and cold weather standards)

ASTM-D975-No 1-D, 2-D

JIS KK 2204

Sulphur content: According to relevant national statutory requirement. If the sulphur content exceeds 0.5 % by weight the **oil change interval** should be changed, see section "Lubricating system".

Fuels with extremely low sulphur contents ("urban diesel" in Sweden and "city diesel" in Finland) may cause a drop in output of 5% and an increase in fuel consumption of 2–3%.

Fuel filter. Replace

Cleanliness! No dirt or contaminants may enter the fuel injection system.

⚠ WARNING! Fuel filter replacement should be carried out on a cold engine to avoid the risk of fire caused by fuel spilling onto hot surfaces.

Remove the filters. Moisten the new filter gasket with a little oil. Screw the filter into place by hand until the gasket touches. And then a further half turn **but no more!** Bleed fuel system. **Take the old filter to a suitable disposal point.**

Start the engine and check for leaks.

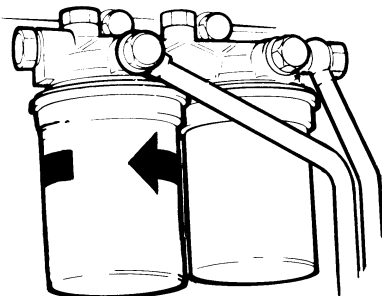

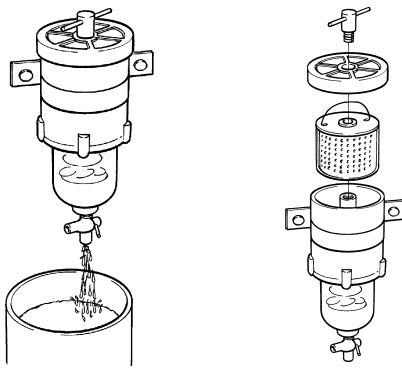

Fuel pre-filter. Drain water (standard on 420–721)

The fuel pre-filter is an optional extra. Position a container under the fuel filter. Drain off water and contaminants using the cock/plug at the bottom.

⚠ IMPORTANT! Wait a few hours after the engine has been turned off before draining the filter.

Cleaning: (Engines 420–721)

- Close fuel stopcock.
- Place the fuel pan beneath the preliminary fuel filter.
- Remove drain plug 4 and drain off fuel.
- Unscrew clamping screw 1, remove filter housing 5 with filter insert 3.
- Clean sealing surface of the filter bracket 7 and filter insert housing 5 of any dirt.
- Insert new sealing ring 6 and filter insert 3 (change as necessary).
– Push the filter insert up to approx. 3 cm over the edge of the housing onto the guide in the filter housing 5.
- Press filter housing 5 with filter insert 3 and sealing ring 6 against the filter console 7 and screw into place with clamping screw 1 (tightening torque 25 Nm).
Note: it must be possible to push the upper seal 2 on filter insert 3 over the guide bracket on filter console 7.
- Tighten drain plug 4.
- Open fuel stopcock.
- Check for leaks after the engine has been started.

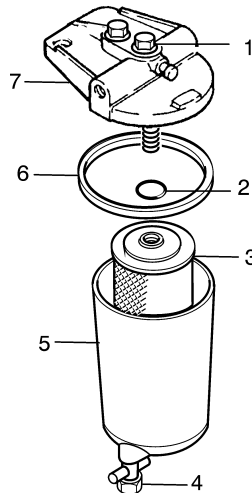

Fuel pre-filter. Filter insert replacement

Close fuel cock at the fuel tank. Position a container under the fuel filter.

Unscrew the screw (1) to remove the cover. Replace insert and reinstall cover. Open fuel cock. Bleed fuel system. **Take the old filter to a suitable disposal point.**

Start the engine and check for leaks.

NOTE! Engines 420–721 have a fuel pre-filter that is possible to clean.

Changing

- Replace defective filter insert 3.

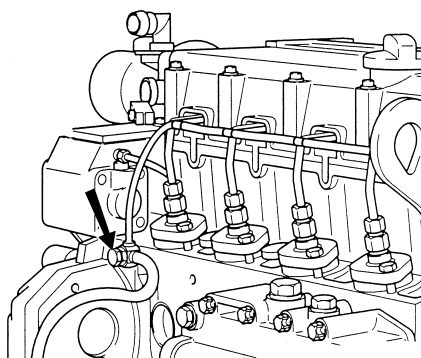
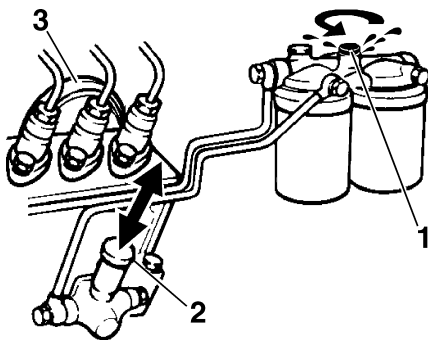

TD/TAD520/720

Fuel system Venting

The fuel system must be vented after fuel filters have been replaced or after refilling the fuel tank after it has been run dry.

Venting engines with stop solenoid/fuel shut-off valve connected to supply voltage at stop:

Ensure that the engine is in operational mode. Open the bleed screw (1). Pump with hand pump (2) until fuel containing no air flows out. Close screw while fuel is flowing out.

Then pump a further 15–20 times. Check for leaks.

NOTE! For engines equipped with a fuel shut-off valve, the fuel injection pump often requires venting as well. This is done by slackening off the fuel injection pump pressure equaliser (3) (27 mm narrow U wrench). Pump with hand pump (2) until fuel containing no air flows out.

Engines 420–721:

Open the air-venting plug in the overflow valve. (See fig.) Crank the engine on the starter motor or use the manual feedpump (optional equip.) until the fuel flow is free from air. Close the plug while the fuel is still flowing.

NOTE! Do not loosen the injectors delivery pipes.

Venting engines with fuel shut-off valve connected to supply voltage during operation:

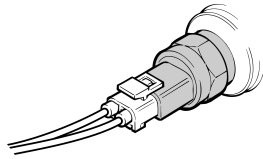

Is there “automatic stop in the event of too low oil pressure” with a Volvo Penta oil pressure switch? When the engine is off, this switch is closed (“Nc”- Normally closed).

Yes

No

Disconnect the connector at the oil pressure switch.

SB= black
BL-W= blue-white

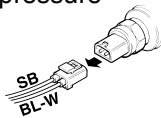

Is there “automatic stop in the event of too low oil pressure” with a non-Volvo Penta oil pressure switch that is open when the engine is off. (“No” = Normally open)

Yes

No

Is the engine equipped with a Volvo Penta instrument box?

Short-circuit the connector for the oil pressure switch with a loop.

Yes

No

Engines with a Volvo Penta instrument box

1. If there is a coolant level alarm – check the level. If the level is too low, the level alarm stops the engine.
2. Briefly press the “Starter button”. The instrumentation is now activated and the charge lamp lights. If there is a coolant level alarm: Hold in the “Interlock button” for approximately 4 seconds.
3. Vent the fuel system according to the instructions on the previous page.
4. Press the “Stop button”
5. Reconnect the connector
6. The engine is now operational

Engines with ignition switch

1. Turn the ignition switch to operating position / ignition. In Volvo Penta ignition switch position 1 (15+)
2. The solenoid valve is now activated for operation (not stop position)
3. Vent the fuel system according to the standard procedures (see the previous page).
4. The engine is now operational

Electrical system

⚠ WARNING! Always stop the engine and break the current using the main switch before working on the electrical system. Isolate battery charger, or other accessories mounted on the engine.

NOTE! NO ELECTRICAL SYSTEM AVAILABLE FOR ENGINES 420–721.



Fuses

The engine has automatic fuses located in the junction box. The fuses break the current when there is an overload in the electrical system.

If the engine cannot be started or the instruments stop operating during operation, the fuse may have tripped. Reset the fuse by pressing on the button on the fuse.

⚠ IMPORTANT! Always investigate the cause of an overload before resetting the fuse!

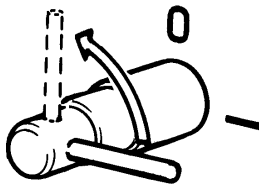

Main switch

The main switch must never be turned off before the engine has stopped. If the circuit between the generator and the battery is cut off when the engine is running the generator can be seriously damaged.

⚠ IMPORTANT! Never break the circuit with the main switch while the engine is running.

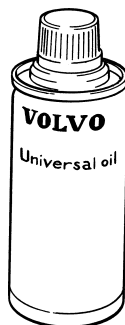

Electrical connections

Also check that all electrical connections are dry and free of oxidation and that there are no loose connections. If necessary, spray these connections with a water-repellent spray (Volvo Penta Universal oil).



Battery. Maintenance and care

⚠ WARNING! Risk of fire and explosion. Never allow an open flame or electric sparks near the battery or batteries.

⚠ WARNING! Never mix up battery positive and negative terminals. This may cause sparks and an explosion.

⚠ WARNING! The battery electrolyte contains extremely corrosive sulphuric acid. Protect your skin and clothes when charging or handling batteries. Always use protective goggles and gloves. If battery electrolyte comes into contact with unprotected skin, wash off immediately using plenty of water and soap. If battery acid comes into contact with the eyes, flush immediately with plenty of water and obtain medical assistance without delay.

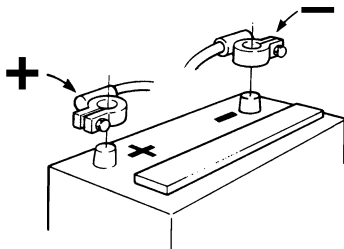

Connecting and disconnecting

First connect the red battery lead + to the battery + terminal. Then connect the black battery lead – to the battery – terminal.

When disconnecting the battery, disconnect the – lead (black) first and then the + lead (red).

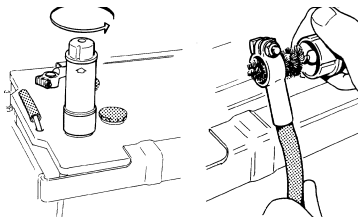

Cleaning

Keep batteries dry and clean. Oxidation or dirt on the battery and battery terminals can cause short-circuits, voltage drop and discharge especially in damp weather. Clean the battery terminals and leads to remove oxidation using a brass brush. Tighten the cable terminals well and grease them with terminal grease or petroleum jelly.

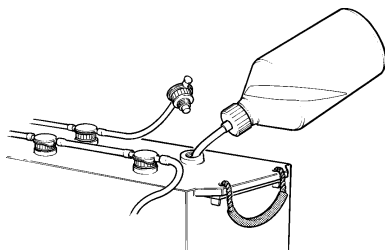

Topping up

The electrolyte should be 5 – 10 mm over the plates in the battery. Top up using **distilled water** if necessary. Charge the battery after topping up for at least 30 minutes by running the engine at fast idle. **NOTE!** Certain maintenance-free batteries have special instructions which must be followed.

Wiring diagram, proposal (TD/TAD520, 720 engines)

- | | |
|-------------------------------|-------------------------------------|
| 1. Battery | 18. Signal horn |
| 2. Main switch | 46. Water level switch (720-models) |
| 3. Starter motor | 52. Start button |
| 4. Alternator | 52a. Start relay |
| 8. Fuse | 53. Interlocking button |
| 10. Oil pressur sender | 54. Stop button |
| 11. Temp sender/switch engine | 57. Charging control lamp |
| 14. Oil pressure switch | 58. Oil pressure gauge |
| 15. Temp sender/switch engine | 59. Water temperature gauge |
| 16. Relay | 61. Hourmeter |
| 17. Stop solenoid | 65. Switch for instrument light |
| | 66. Instrument light |
| | 84. Holding current relay |

Cable area

	12V	24V
A.	90 mm ²	70 mm ²
B.	10 mm ²	2.5 mm ²
C.	2.5 mm ²	2.5 mm ²
D.	10 mm ²	6 mm ²
E.	6 mm ²	2.5 mm ²
Not specified cable area 1 mm ²		

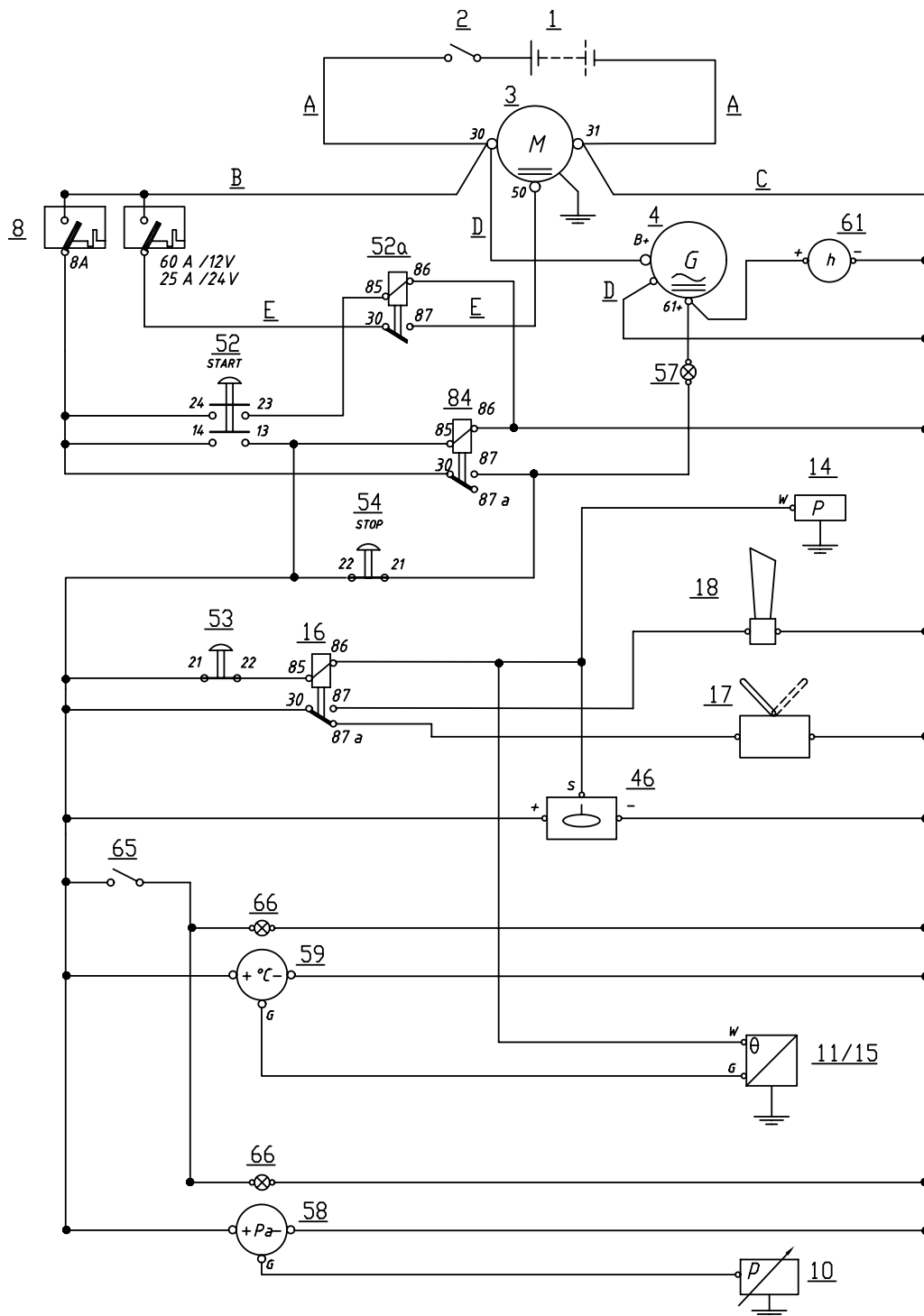

Wiring diagram (6–12 litre engines)

“Not for TD/TAD720”

1. Oil pressure gauge
2. Engine coolant temperature gauge
3. Tachometer with built-in hours run meter
4. Charge warning lamp
5. Semi-automatic fuses (manual resetting)
6. Stop button
7. Interlock
8. Starter button
9. Relay for engine coolant level switch (accessory)
10. Relay for engine coolant temperature (ECT) switch, oil pressure switch
11. Holding current relay (operating current and instruments)
12. Terminal block (auxiliary power output, with 16A fuse, output for automatic stop, closes in the event of a fault).
13. Relay for starter element
14. Starter element
15. Starter motor
16. Batteries
17. Generator
18. Engine speed (rpm) sensor
19. Engine coolant temperature sensor
20. Engine coolant temperature (ECT) switch (normally open)
21. Oil pressure sensor
22. Oil pressure switch (normally open)
23. Engine coolant level switch (accessory)
24. Stop solenoid (current bearing during operation)
25. Horn
26. Joint splice
27. Main switch
28. Engine speed (rpm) sensor
29. Relay
30. Engine speed governor
31. Fuse

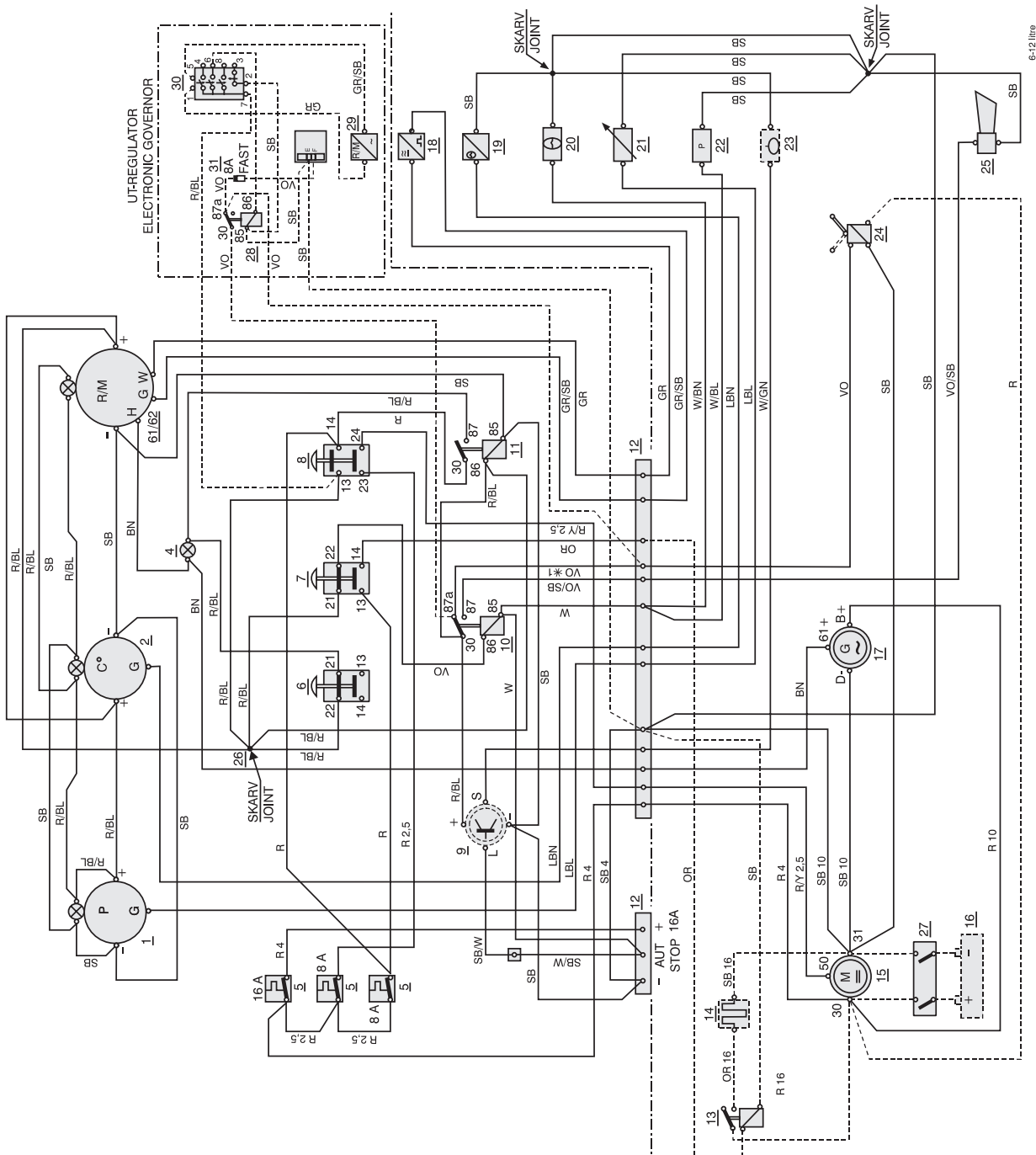

*1 Remove when setting the UT governor

Wiring diagram (16-litre engines)

Cable areas in mm² (indicated after the colour codes in the wiring diagrams).

If no cable area is stated, the default is 1.5 mm²

Cable colour

- BL = Blue
- LBL = Light blue
- BN = Brown
- LBN = Light brown
- GN = Green
- GR = Grey
- OR = Orange
- VO = Violet
- R = Red
- SB = Black
- W = White
- Y = Yellow

The area of the battery leads depends on the location of the battery.

Distance starter motor – batteries

- max. 2 m, area = 70 mm²
- max. 4 m, area = 120 mm²

Conversions mm² / AWG*

*American Wiring Gauge

mm ²	AWG
1.0	16 (17)
1.5	15 (16)
2.5	13
10	7
16	5

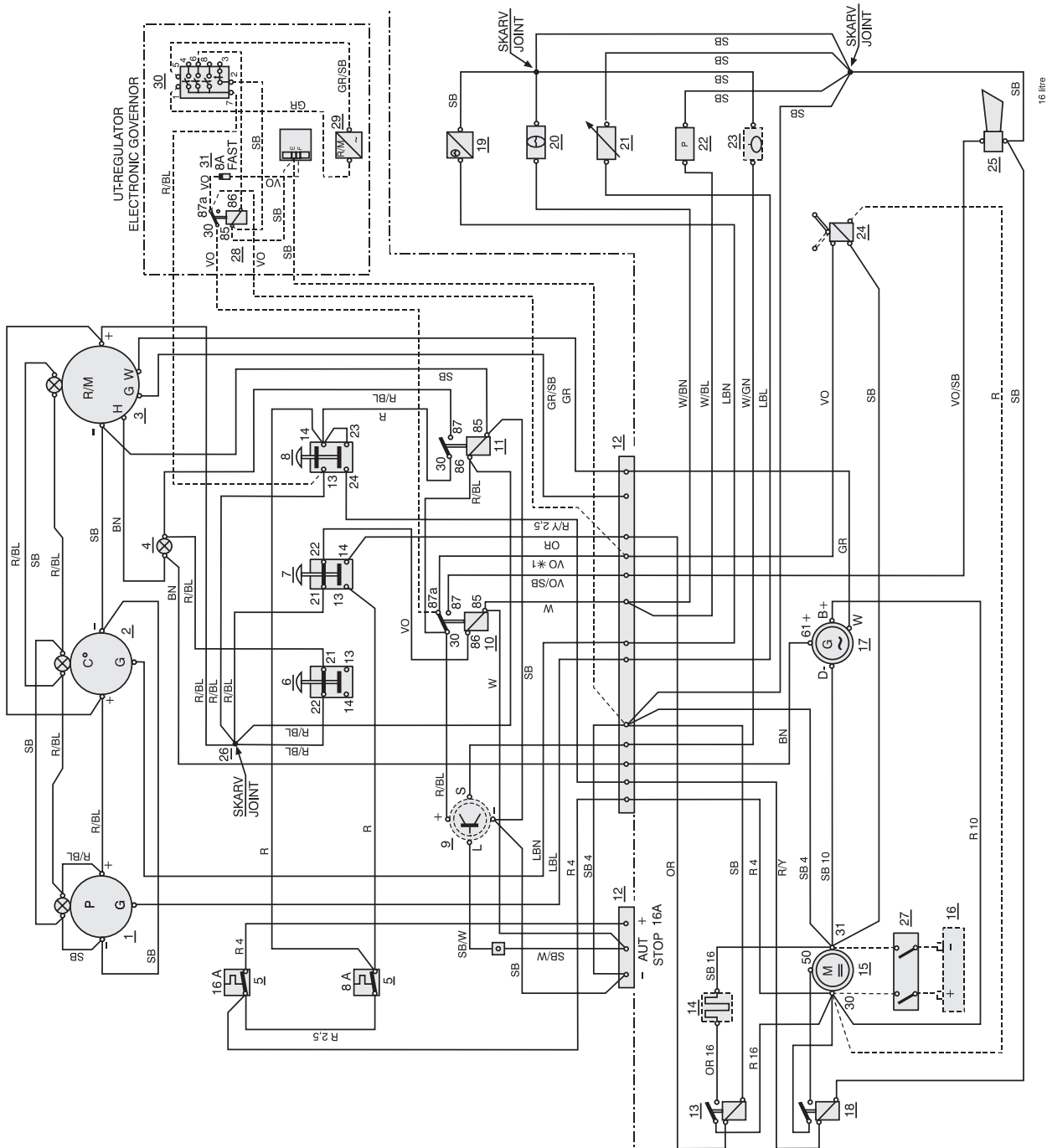

Instrument box

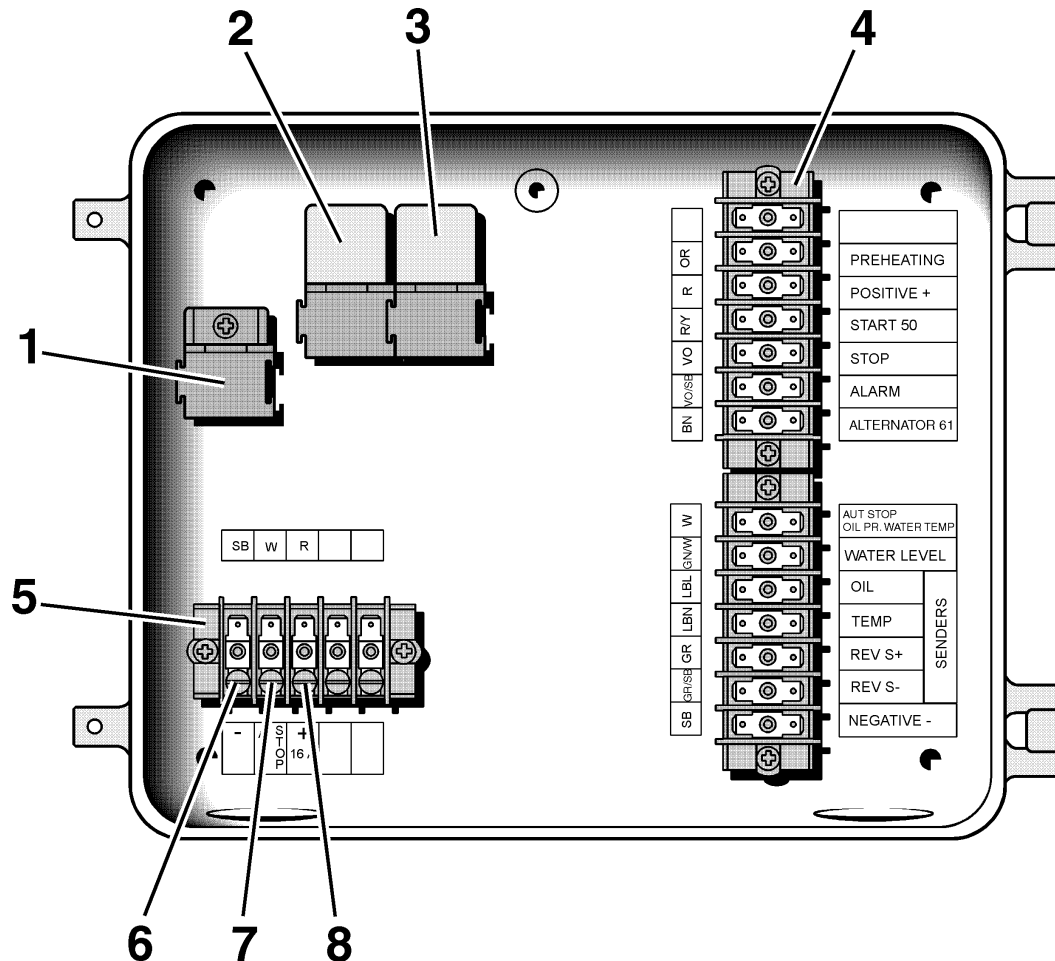

1. Location for level switch relay: coolant (accessory)
2. Relay for automatic stop: engine coolant temperature (ECT) switch, oil pressure switch and low coolant temperature switch (accessory).
3. Holding current relay (operating current and instruments)
4. Terminal block for engine cable harness
5. Terminal block for automatic stop and extra power output (maximum 16 A)
6. Negative (-) for extra power output (black cable)
7. Connection for any extra switches – automatic stop (white cable)
8. Positive (+) for extra power output (red cable) Maximum 16 A

Alarm separator for the instrument box (accessory)

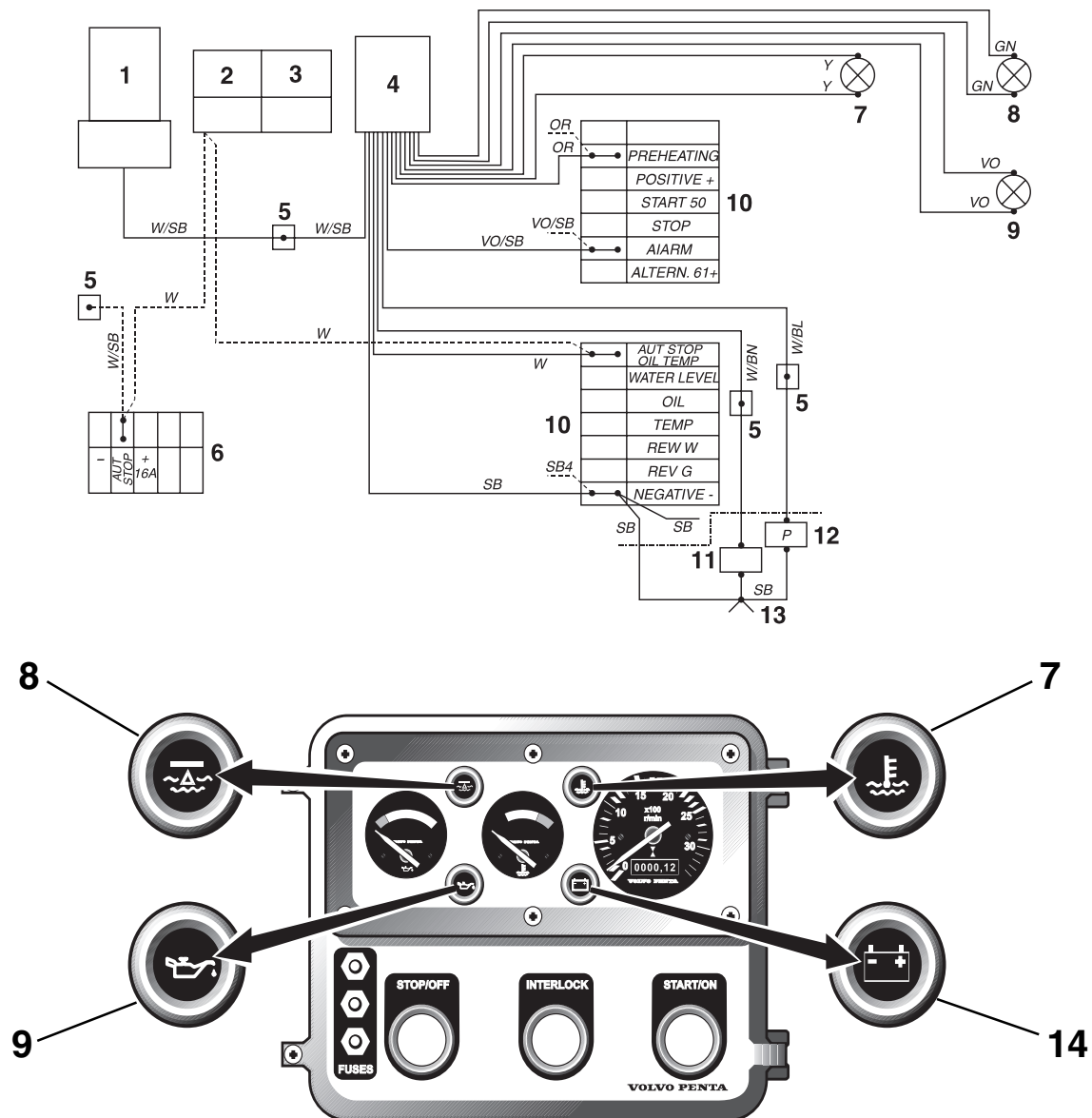

1. Relay for engine coolant level switch (accessory)
2. Relay for engine coolant temperature (ECT) switch, oil pressure switch
3. Holding current relay (operating current and instruments)
4. Alarm separator
5. Splice section
6. Terminal block for auxiliary power output (16 A fuse) and output for automatic stop, (closes in the event of a fault).
7. Warning lamp, high engine coolant temperature (accessory)
8. Warning lamp, low engine coolant level (accessory)
9. Warning lamp, low lubrication oil pressure (accessory)
10. Terminal block for engine cable harness
11. Engine coolant temperature (ECT) switch (normally open)
12. Oil pressure switch (normally open)
13. Joint splice
14. Warning lamp, generator not charging

Cables displayed as a dashed lines are existing cables

Time relay kit for engagement of the starter element (accessory)

1. Time relay
2. Connector. 8 pin
3. Ignition switch
4. Temperature switch (accessory)
5. Starter element
6. Indicator lamp (engaged starter element)
7. Battery

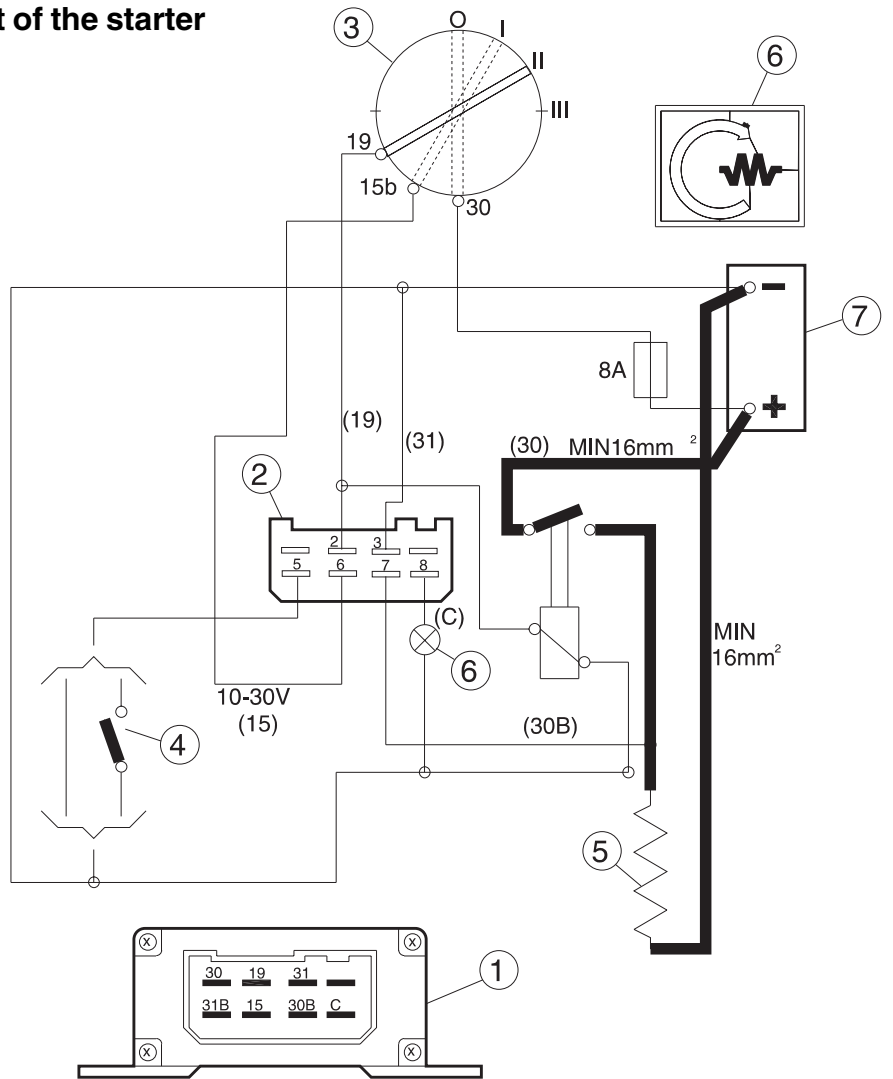

Disengageable clutch and compressor

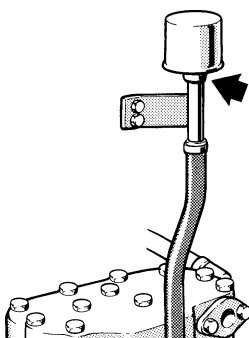
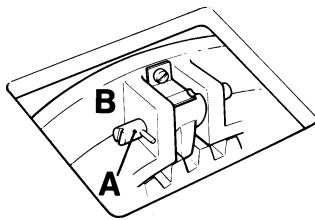
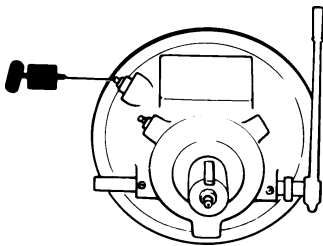
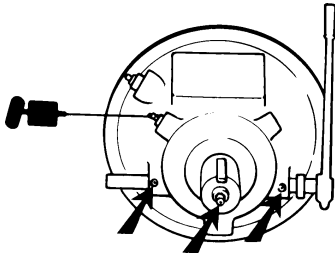

Disengageable clutch

Lubrication

Use lithium based grease, Mobilux EP2, Statoil Uniway EP2N, Texaco Multifak EP2, Q8 Rembrandt EP2 for example

Main bearing and clutch mechanism

Lubricate inner support bearing (when a grease nipple is installed), main bearings, disengaging shaft and moving parts of clutch. Lubricate sparingly (20–30 g for main bearings).

Lubricate the inner control arms with a few drops of oil.

Disengagement bearing

Lubricate sparingly so that no grease is squeezed out. Use a grease recommended above.

Checking and adjusting

⚠ WARNING! Adjustments may only be made on a stopped engine.

The clutch force at the end of the lever must be 34–41 kp (double clutch plates) or 36–45 kp (triple clutch plates) during engagement.

Adjustment: Remove the inspection cover. Disconnect catch (A) and turn the red adjuster (B) clockwise. Engage the catch. The clutch plates must not slip after engagement!

Air Compressor

Air filter. Replace

Slacken off hose clamp, remove the filter for disposal. Install a new filter and tighten the clamp.

Shut down

Inhibition should be carried out to ensure that the engine and other equipment are not damaged while shut down. It is important that this is done properly and that nothing is forgotten. We have therefore provided a checklist covering the most important points.

Before shutting down for a long period, an authorised Volvo Penta workshop should inspect the engine and other equipment. Have any necessary repairs or service work carried out so that the equipment is in good condition for the next time it is started.

⚠ WARNING! Read the chapter “Maintenance” carefully before starting work. It contains instructions on how to carry out the work safely and correctly.

Storage

- Change engine oil and replace oil filter.
- Replace fuel filter. Replace fuel pre-filter if installed.
- Run engine to normal operating temperature.
- Check the condition of the engine coolant anti-freeze. Top up if required.

⚠ IMPORTANT! An anti-corrosion mixture in the engine coolant system provides no protection against freezing. If there is any possibility the engine will be subjected to freezing temperatures, the system must be drained.

- Drain any water and contaminants from the fuel tank. Fill the tank completely with fuel to avoid condensation.
- Clean the outside of the engine. Do not use a high pressure spray to clean the engine. Touch up any damaged areas of paintwork with Volvo Penta original paint.
- Disconnect the battery leads. Clean and charge the batteries. NOTE! A poorly charged battery may burst as a result of freezing.
- Spray electrical system components with moisture-repellent spray.

Bringing out of storage

- Check the engine oil level. Top up if necessary. If there is inhibiting oil in the system, drain and fill with new oil, change oil filter. For correct oil grade: See chapter “Maintenance”, lubrication system.
- Close/tighten drain cocks/plugs.
- Check drive belts.
- Check the condition of rubber hoses and tighten hose clamps.
- Check engine coolant level and antifreeze protection. Top up if necessary.
- Connect the fully charged batteries.
- Start the engine. Check that there are no fuel, engine coolant or exhaust gas leaks and that all control functions are operating.

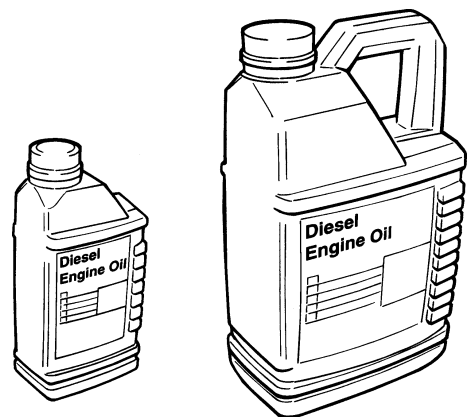

Fault tracing

A number of symptoms and possible reasons for engine problems are described in the table below. In case of faults or mishaps which you cannot solve, always contact the Volvo Penta dealership.

In the event of engine interference related to the GAC governor (Generating set engines), refer to the documentation delivered with the GAC governor.

 **WARNING!** Read the safety precautions for maintenance and service in the chapter: "Safety Information", before starting work.

Symptoms and possible causes

Starter motor not turning (or turning slowly)	1, 2, 3, 21, 22, 23, 24
Engine will not start	4, 5, 6, 7, 25, 26, 31
Engine starts but stops again	4, 6, 7, 8, 25, 26
Engine difficult to start	4, 5, 6, 7, 25, 26, 31
Engine does not reach correct speed at wide open throttle (WOT)	4, 5, 6, 7, 8, 9, 29, 30, 31
Engine knocks	4, 5, 6, 7
Engine runs unevenly	4, 5, 6, 7, 8, 9, 31
Engine vibrates	13, 14
High fuel consumption	8, 10
Black exhaust smoke	8, 28
Blue or white exhaust smoke	10, 19, 28
Low oil pressure	11, 12
Engine coolant temperature too high	15, 16, 17, 18, 27, 28
No or poor charging	2, 20

- | | | |
|---|--|--|
| 1. Discharged battery | 12. Blocked fuel filter | 23. Defective starter motor / solenoid |
| 2. Loose connection / open-circuit | 13. Defective engine mounting | 24. Water in the engine |
| 3. Fuse tripped | 14. Worn clutch | 25. Preheating insufficient |
| 4. Lack of fuel | 15. Too little coolant | 26. Starter element defective / not connected |
| 5. Fouled fuel filter. | 16. Radiator blocked | 27. Defective temperature gauge / sensor |
| 6. Air in the fuel injection system | 17. Circulation pump defective | 28. Faulty injection timing |
| 7. Water / contaminants in the fuel | 18. Defective / incorrect thermostat | 29. Engine overloaded |
| 8. Insufficient air supply | 19. Lubricating oil level too high | 30. Excessive back pressure in exhaust system |
| 9. Engine coolant temperature too high | 20. Generator drive belt slipping | 31. Fault in the GAC unit (generating set engines) |
| 10. Engine coolant temperature is too low | 21. Defective ignition switch / starter button | |
| 11. Lubricating oil level too low. | 22. Defective start relay | |

Technical Data

General

Designation	No. of cylinders	Cylinder displacement (litres)	Weight (kg)*
TD420VE	4	4,04	380**
TAD420VE	4	4,04	380**
TD520GE	4	4,76	550**
TD520VE	4	4,76	430**
TAD520GE	4	4,76	575**
TAD520VE	4	4,76	532**
TAD620VE	6	5,07	495**
TWD630VE	6	5,48	665
TD640VE	6	5,48	655
TD71A	6	6,73	760
TWD710V	6	6,73	770
TD730VE	6	6,73	760
TWD731VE	6	6,73	770
TAD730V	6	6,73	876
TD710G	6	6,73	785
TWD710G	6	6,73	795
TD720GE	6	7,15	750**
TD720VE	6	7,15	570**
TAD720GE	6	7,15	760**
TAD720VE	6	7,15	572**
TAD721VE	6	7,15	572**
TWD740GE/VE	6	7,28	795
TAD740GE	6	7,28	901**
TAD741GE	6	7,28	901**
TD100G	6	9,6	945
TD1030VE	6	9,6	945
TWD1031VE	6	9,6	975
TAD1030V	6	9,6	1062
TAD1030GE	6	9,6	1107
TAD1031/32GE	6	9,6	1107
TD121G	6	11,98	1075
TWD1210V	6	11,98	1105
TWD1211V	6	11,98	1105
TWD1230VE	6	11,98	1105
TAD1230V	6	11,98	1215
TD1210G	6	11,98	1110
TWD1210G	6	11,98	1140
TWD1211G	6	11,98	1140
TAD1230G	6	11,98	1250
TAD1231GE	6	11,98	1250
TAD1232GE	6	11,98	1250
TD164KAE	6	16,12	1430
TWD1630V	6	16,12	1409
TAD1630V	6	16,12	1515
TWD1630G	6	16,12	1428
TWD1630GE	6	16,12	1428
TAD1630GE	6	16,12	1538
TAD1631G/GE	6	16,12	1538

* Engine only (without coolant and oil)

**Including radiator and charge air cooler (CAC)

General

Designation	Low idling speed (rpm)	Valve clearance, intake/exhaust (mm)*
TD420VE	875±50	0,35/0,55
TAD420VE	875±50	0,35/0,55
TD520GE	875±50	0,35/0,55
TD520VE	875±50	0,35/0,55
TAD520GE	875±50	0,35/0,55
TAD520VE	875±50	0,35/0,55
TAD620VE	875±50	0,35/0,55
TWD630VE	725±25	0,40/0,55
TD640VE	700±10	0,40/0,55
TD71A	600±25	0,40/0,55
TWD710V	600±25	0,40/0,55
TD730VE	650±25	0,40/0,55
TWD731VE	650±25	0,40/0,55
TAD730V	600±25	0,40/0,55
TD710G	1300±50	0,40/0,55
TWD710G	1300±50	0,40/0,55
TD720GE	875±50	0,35/0,55
TD720VE	875±50	0,35/0,55
TAD720GE	875±50	0,35/0,55
TAD720VE	875±50	0,35/0,55
TAD721VE	875±50	0,35/0,55
TWD740GE/VE	1300±50	0,50/0,65
TAD740GE	1300±50	0,50/0,65
TAD741GE	1300±50	0,50/0,65
TD100G	550±50	0,40/0,70
TD1030VE	600±25	0,40/0,70
TWD1031VE	675±25	0,40/0,70
TAD1030V	600±25	0,40/0,70
TAD1030GE	1300±50	0,40/0,70
TAD1031/32GE	1300±50	0,40/0,70
TD121G	600±50	0,40/0,70
TWD1210V	600±25	0,40/0,70
TWD1211V	600±25	0,40/0,70
TWD1230VE	600±25	0,40/0,70
TAD1230V	600±25	0,40/0,70
TD1210G	1300±50	0,40/0,70
TWD1210G	1300±50	0,40/0,70
TWD1211G	1300±50	0,40/0,70
TAD1230G	1300±50	0,40/0,70
TAD1231GE	1300±50	0,40/0,70
TAD1232GE	1300±50	0,40/0,70
TD164KAE	850±50	0,30/0,60
TWD1630V	500±25	0,30/0,60
TAD1630V	500±25	0,30/0,60
TWD1630G	1300±50	0,30/0,60
TWD1630GE	1300±50	0,30/0,60
TAD1630GE	1300±50	0,30/0,60
TAD1631G/GE	1300±50	0,30/0,60

* Applies to cold engine or at operating temperature (stopped)

Oil pressure*

Designation	At normal running engine speed (kPa)	At idling speed (kPa)
TD420VE	450	min. 80
TAD420VE	450	min. 80
TD520GE	400	min. 150
TD520VE	450	min. 80
TAD520GE	400	min. 150
TAD520VE	450	min. 80
TAD620VE	450	min. 80
TWD630VE	300-500	min. 150
TD640VE	300-500	min. 150
TD71A	300-500	min. 150
TWD710V	300-500	min. 150
TD730VE	250-550	min. 150
TWD731VE	250-550	min. 150
TAD730V	300-500	min. 150
TD710G	300-500	min. 150
TWD710G	300-500	min. 150
TD720GE	420	min. 150
TD720VE	450	min. 80
TAD720GE	420	min. 150
TAD720VE	450	min. 80
TAD721VE	450	min. 80
TWD740GE/VE	300-500	min. 150
TAD740GE	300-500	min. 150
TAD741GE	300-500	min. 300
TD100G	300-500	min. 150
TD1030VE	400-600	min. 150
TWD1031VE	400-600	min. 150
TAD1030V	300-500	min. 150
TAD1030GE	300-500	min. 150
TAD1031/32GE	300-500	min. 300
TD121G	300-500	min. 150
TWD1210V	300-500	min. 150
TWD1211V	300-500	min. 150
TWD1230VE	300-500	min. 150
TAD1230V	300-500	min. 150
TD1210G	300-500	min. 150
TWD1210G	300-500	min. 150
TWD1211G	300-500	min. 150
TAD1230G	300-500	min. 150
TAD1231GE	300-500	min. 150
TAD1232GE	300-500	min. 150
TD164KAE	300-500	min. 150
TWD1630V	300-500	min. 150
TAD1630V	300-500	min. 150
TWD1630G	300-500	min. 150
TWD1630GE	300-500	min. 150
TAD1630GE	300-500	min. 150
TAD1631G/GE	300-500	min. 150

* Applies to engine at operating temperature

Oil change capacity* for standard oil pan

Designation	Without oil filter (litres)	With oil filter (litres)	Volume difference (MIN-MAX)**
TD420VE	8	10	2
TAD420VE	8	10	2
TD520GE	11	13	2
TD520VE	11	13	2
TAD520GE	11	13	2
TAD520VE	11	13	2
TAD620VE	14	16	3
TWD630VE	20	24	6
TD640VE	20	24	6
TD71A	24	29	8
TWD710V	22	27	7
TD730VE	24	29	8
TWD731VE	24	29	8
TAD730V	22	27	7
TWD710G	24	29	7
TD720GE	18	20	3
TD720VE	18	20	3
TAD720GE	18	20	3
TAD720VE	18	20	3
TAD721VE	18	20	3
TAD730G	24	29	8
TWD740GE/VE	24	29	8
TAD740GE	24	29	8
TAD741GE	24	29	8
TD100G	21	25	9
TD1030VE	32	36	10
TWD1031VE	32	36	10
TAD1030V	30	34	8
TAD1030GE	32	36	10
TAD1031/32GE	32	36	10
TD121G	34	38	9
TWD1210V	34	38	9
TWD1211V	34	38	9
TWD1230VE	34	38	9
TAD1230V	34	38	9
TD1210G	34	38	9
TWD1210G	34	38	9
TWD1211G	34	38	9
TAD1230G	34	38	9
TAD1231GE	34	38	9
TAD1232GE	34	38	9
TD164KAE	57	64	3
TWD1630V	57	64	17
TAD1630V	57	64	17
TWD1630G	57	64	17
TWD1630GE	57	64	17
TAD1630GE	57	64	17
TAD1631G/GE	57	64	17

* Information about oil quality and viscosity can be found in the "Maintenance" chapter under the heading Lubrication system

** Difference in volume in litres between the MIN and MAX markings on the dipstick

Oil change capacity* for (shallow 10°) oil Pan

Designation	Without oil filter (litres)	With oil filter (litres)	Volume difference (MIN-MAX)**
TD610V	12	16	5
TD630VE	12	16	5
TWD630VE	12	16	5
TD71A	14	19	7
TID71A	14	19	7
TD730VE	14	19	7
TWD731VE	14	19	7

Oil change capacity* for (shallow) oil pan for large inclinations

Designation	Without oil filter (litres)	With oil filter (litres)	Volume difference (MIN-MAX)**
TD610V	15	19	3
TD630VE	15	19	3
TWD630VE	15	19	3
TD71A	19	24	3
TID71A	19	24	3
TD730VE	19	24	3
TWD731VE	19	24	3
TWD1230VE	30	34	12

Oil change capacity* for (deep) oil pan for large inclinations

Designation	Without oil filter (litres)	With oil filter (litres)	Volume difference (MIN-MAX)**
TD610V	18	22	6
TD630VE	18	22	6
TWD630VE	18	22	6
TD100G	27	31	9
TD1030VE	27	31	11
TWD1031VE	27	31	11
TD121G	30	34	12
TWD1230VE	30	34	12

* Information about oil quality and viscosity can be found in the “Maintenance” chapter under the heading Lubrication system

** Difference in volume between the MIN and MAX markings on the dipstick

Oil change capacity* for (vehicle type) oil pans

Designation	Without oil filter (litres)	With oil filter (litres)	Volume difference (MIN-MAX)**
TD71A	22	27	7
TID71A	22	27	7
TD730VE	22	27	7
TWD731VE	22	27	7

Oil change capacity* for (laminated) oil pan (soundproofed)

Designation	Without oil filter (litres)	With oil filter (litres)	Volume difference (MIN-MAX)**
TD630VE	20	24	6
TWD630VE	20	24	6
TD730VE	22	27	7
TWD731VE	22	27	7
TD1030VE	32	36	10
TWD1031VE	32	36	10
TWD1230VE	34	38	12

* Information about oil quality and viscosity can be found in the "Maintenance" chapter under the heading Lubrication system

** Difference in volume between the MIN and MAX markings on the dipstick

Cooling system

Designation	Coolant volume (litres)*	Thermostat begins to open/fully open at (°C)
TD420VE	17	83/95**
TAD420VE	17	83/95**
TD520GE	18	83/95**
TD520VE	18	87/102**
TAD520GE	20	83/95**
TAD520VE	20	87/102**
TAD620VE	21	83/95**
TWD630VE	22	75/88**
TD640VE	22	75/88**
TD71A	25	75/88**
TWD710V	34	75/88**
TD730VE	25	75/88**
TWD731VE	26	75/88**
TAD730V	37	75/88**
TWD710G	42	75/88**
TD720GE	22	83/95**
TD720VE	22	87/102**
TAD720GE	24	83/95**
TAD720VE	24	87/102**
TAD721VE	24	87/102**
TAD730G	37	75/88**
TWD740GE/VE	42	75/88**
TAD740GE	37	75/88**
TAD741GE	37	75/88**
TD100G	27	82/95**
TD1030VE	30	82/95**
TWD1031VE	30	75/88**
TAD1030V	38	82/95**
TAD1030GE	38	86/96**
TAD1031/32GE	38	86/96**
TD121G	34	82/95**
TWD1210V	49	75/88**
TWD1211V	55	82/95**
TWD1230VE	37	82/95**
TAD1230V	48	82/95**
TD1210G	49	75/88**
TWD1210G	52	75/88**
TWD1211G	59	75/88**
TAD1230G	48	82/95**
TAD1231GE	48	82/95**
TAD1232GE	48	82/95**
TD164KAE	90	82/95**
TWD1630V	59	75/88***
TAD1630V	52	82/95***
TWD1630G	59	75/88***
TWD1630GE	59	75/88***
TAD1630GE	52	82/95***
TAD1631G/GE	56	82/95***

* The coolant volumes listed apply to the use of Volvo Penta original coolants

** Number of thermostats: 1

*** Number of thermostats: 2

Fuel system*. Injectors

Designation	Opening pressure (MPa)	Adjusting pressure (MPa)	Nozzle hole diameter (mm)
TD420VE	22,0	23,0 +0,8	6 st 0,203
TAD420VE	22,0	23,0 +0,8	6 st 0,203
TD520GE	25,0	26,0 +0,8	5 st 0,30
TD520VE	25,0	26,0 +0,8	5 st 0,30
TAD520GE	25,0	26,0 +0,8	5 st 0,30
TAD520VE	25,0	26,0 +0,8	5 st 0,30
TAD620VE	22,0	23,0 +0,8	6 st 0,203
TWD630VE	25,0	26,0 +0,8	6 st 0,226
TD640VE	25,0	26,0 +0,8	6 st 0,226
TD71A	25,0	25,5 +0,8	4 st 0,34
TWD710V	25,0 +0,8	25,5 +0,8	4 st 0,38
TD730VE	25,5	26,0 +0,8	7 st 0,235
TWD731VE	25,0	26,0 +0,8	6 st 0,258
TAD730V	30,0 +0,8	30,5 +0,8	5 st 0,35
TWD710G	25,0 +0,8	25,5 +0,8	4 st 0,38
TD720GE	27,5 +0,8	28,0 +0,8	5 st 0,30
TD720VE	27,5 +0,8	28,0 +0,8	5 st 0,30
TAD720GE	27,5 +0,8	28,0 +0,8	5 st 0,30
TAD720VE	27,5 +0,8	28,0 +0,8	5 st 0,30
TAD721VE	27,5 +0,8	28,0 +0,8	5 st 0,30
TAD730G	30,0 +0,8	30,5 +0,8	5 st 0,32
TWD740GE/VE	29,0 +0,8	29,5 +0,8	6 st 0,29
TAD740GE	29,0 +0,8	29,5 +0,8	6 st 0,29
TAD741GE	29,0 +0,8	29,5 +0,8	6 st 0,29
TD100G	26,0 +0,8	26,5 +0,8	4 st 0,38
TD1030VE	25,0	26,0 +0,8	7 st 0,27
TWD1031VE	25,0	26,0 +0,8	6 st 0,25
TAD1030V	27,5 +0,8	28,0 +0,8	5 st 0,30
TAD1030GE	27,5	28,0	5 st 0,30
TAD1031GE	25,0 + 0,8	25,5 + 0,8	6 st 0,24
TAD1032GE	25,0 + 0,8	25,5 + 0,8	6 st 0,27
TD121G	27,0	27,5 +0,8	5 st 0,36
TWD1210V	27,0 +0,8	27,5 +0,8	5 st 0,38
TWD1211V	27,0 +0,8	27,5 +0,8	5 st 0,38
TWD1230VE	25,0	26,0 +0,8	6 st 0,28
TAD1230V	25,5 +0,8	26,0 +0,8	5 st 0,38
TD1210G	26,5	27,0	5 st 0,36
TWD1210G	27,0 +0,8	27,5 +0,8	5 st 0,38
TWD1211G	27,0	27,5 +0,8	5 st 0,38
TAD1230G	25,5	26,0 +0,2	5 st 0,38
TAD1231GE	25,5	26,0 +0,2	6 st 0,34
TAD1232GE	25,5	26,0 +0,2	6 st 0,34
TD164KAE	23,5	24,0 +0,2	7 st 0,31
TWD1630V	26,0	26,5 +0,2	7 st 0,31
TAD1630V	26,0	26,5 +0,2	7 st 0,31
TWD1630G	26,0	26,5 +0,2	7 st 0,31
TWD1630GE	26,0	26,5 +0,2	7 st 0,31
TAD1630GE	26,0	26,5 +0,2	7 st 0,31
TAD1631G/GE	28,5	29,0 +0,2	7 st 0,35

* Refer to the engine identification plate for information about injection timing and stroke position. See the chapter "Presentation", identification number.

Electrical system

Designation	System voltage (V)	Maximum battery capacity 24 V/12 V (Ah)
TD420VE	24 alt. 12	2x110/2x88
TAD420VE	24 alt. 12	2x110/2x88
TD520GE	24 alt. 12	2x110/2x88
TD520VE	24 alt. 12	2x110/2x88
TAD520GE	24 alt. 12	2x110/2x88
TAD520VE	24 alt. 12	2x110/2x88
TAD620VE	24 alt. 12	2x110/2x88
TWD630VE	24 alt. 12	2x135/2x110
TD640VE	24 alt. 12	2x135/2x110
TD71A	24 alt. 12	2x135/2x110
TWD710V	24 alt. 12	2x135/2x110
TD730VE	24 alt. 12	2x135/2x110
TWD731VE	24	2x135/ –
TAD730V	24	2x135/ –
TWD710G	24	2x143/ –
TD720GE	24 alt. 12	2x110/2x88
TD720VE	24 alt. 12	2x110/2x88
TAD720GE	24 alt. 12	2x110/2x88
TAD720VE	24 alt. 12	2x110/2x88
TAD721VE	24 alt. 12	2x110/2x88
TAD730G	24	2x143/ –
TWD740GE/VE	24	2x143/ –
TAD740GE	24	2x143/ –
TAD741GE		
TD100G	24	2x143/ –
TD1030VE	24	2x143/ –
TWD1031VE	24	2x143/ –
TAD1030V	24	2x143/ –
TAD1030GE	24	2x143/ –
TAD1031/32GE	24	2x143/ –
TD121G	24	2x143/ –
TWD1210V	24	2x143/ –
TWD1211V	24	2x143/ –
TWD1230VE	24	2x143/ –
TAD1230V	24	2x143/ –
TD1210G	24	2x152/ –
TWD1210G	24	2x152/ –
TWD1211G	24	2x152/ –
TAD1230G	24	2x152/ –
TAD1231GE	24	2x152/ –
TAD1232GE	24	2x152/ –
TD164KAE	24	2x176/–
TWD1630V	24	2x176/ –
TAD1630V	24	2x176/ –
TWD1630G	24	2x176/ –
TWD1630GE	24	2x176/ –
TAD1630GE	24	2x176/ –
TAD1631G/GE	24	2x176/ –

Generator. Voltage/Amperage/Power (V/A/W)

Designation	Alt. 1*	Alt. 2*	Alt. 3*	Alt. 4*	Alt. 5*
TD420VE	14/55/770	28/35/980	–	–	–
TAD420VE	14/55/770	28/35/980	–	–	–
TD520GE	14/55/770	28/35/980	–	–	–
TD520VE	14/55/770	28/35/980	–	–	–
TAD520GE	14/55/770	28/35/980	–	–	–
TAD520VE	14/55/770	28/35/980	–	–	–
TAD620VE	14/55/770	28/35/980	–	–	–
TWD630VE	28/55/1550	28/60/1700	28/80/2240	14/60/840	–
TD640VE	28/55/1550	28/60/1700	28/80/2240	14/60/840	–
TD71A	28/55/1550	28/60/1700	28/80/2240	–	14/90/1260
TWD710V	–	28/60/1700	–	–	14/90/1260
TD730VE	28/55/1550	28/60/1700	28/80/2240	–	14/90/1260
TWD731VE	28/55/1550	28/60/1700	28/80/2240	–	–
TAD730V	–	28/60/1700	–	–	–
TWD710G	–	28/60/1700	–	–	–
TD720GE	14/55/770	28/35/980	–	–	–
TD720VE	14/55/770	28/35/980	–	–	–
TAD720GE	14/55/770	28/35/980	–	–	–
TAD720VE	14/55/770	28/35/980	–	–	–
TAD721VE	14/55/770	28/35/980	–	–	–
TAD730G	–	28/60/1700	–	–	–
TWD740GE/VE	–	28/60/1700	–	–	–
TAD740GE	–	28/60/1700	–	–	–
TAD741GE	–	28/60/1700	–	–	–
TD100G	28/55/1550	28/60/1700	28/80/2240	–	–
TD1030VE	28/55/1550	28/60/1700	28/80/2240	–	–
TWD1031VE	28/55/1550	28/60/1700	28/80/2240	–	–
TAD1030V	–	28/60/1700	–	–	–
TAD1030GE	–	28/60/1700	–	–	–
TAD1031/32GE	–	28/60/1700	–	–	–
TD121G	28/55/1550	28/60/1700	28/80/2240	–	–
TWD1210V	–	28/60/1700	–	–	–
TWD1211V	–	28/60/1700	–	–	–
TWD1230VE	28/55/1550	28/60/1700	28/80/2240	–	–
TAD1230V	–	28/60/1700	–	–	–
TD1210G	–	28/60/1700	–	–	–
TWD1210G	–	28/60/1700	–	–	–
TWD1211G	–	28/60/1700	–	–	–
TAD1230G	–	28/60/1700	–	–	–
TAD1231GE	–	28/60/1700	–	–	–
TAD1232GE	–	28/60/1700	–	–	–
TD164KAE	–	28/60/1700	–	–	–
TWD1630V	–	28/60/1700	–	–	–
TAD1630V	–	28/60/1700	–	–	–
TWD1630G	–	28/60/1700	–	–	–
TWD1630GE	–	28/60/1700	–	–	–
TAD1630GE	–	28/60/1700	–	–	–
TAD1631G/GE	–	28/60/1700	–	–	–

* Alt.1=Generator 55 A/28 V, Alt.2=Generator 60 A/28 V, Alt.3=Generator 80 A/28 V, Alt.4=Generator 60 A/14 V, Alt.5=Generator 90 A/14 V

Disengageable clutch (accessory)

Designation	Type	Gear ratio	Size (mm)	Weight (kg)
AP S11A2	Single plate	1:1	292 (11 1/2")	66
AP D11A2	Double plate	1:1	292 (11 1/2")	83
AP T14A2	Triple plate	1:1	355 (14")	209

ENG

Post or fax this coupon to:

Document & Distribution Center
Order Department
ARU2, Dept. 64620
SE-405 08 Göteborg
Sweden
Fax: +46 31 545 772

Orders can also be placed via the Internet:

<http://www.volvopenta.com/manual/coupon>

Yes please,

I would like an operator's manual in English at no charge.

Publication number: 7739614

Name

Address

Country

NB! This offer is valid for a period of 12 months from delivery of the boat. Availability after this period will be as far as supplies admit.

**VOLVO
PENTA**

42200/615001/155099900192

GER

Schicken Sie den Coupon per Post oder als Fax an:

Document & Distribution Center
Order Department
ARU2, Dept. 64620
SE-405 08 Göteborg
Schweden
Fax: +46 31 545 772

Die Bestellung kann auch über das Internet erfolgen:

<http://www.volvopenta.com/manual/coupon>

Ja,

ich will kostenlos eine Betriebsanleitung in deutscher Sprache erhalten.

Publikationsnummer: 7739615

Name

Anschrift

Land

Bitte beachten Sie, dass dieses Angebot für die Dauer von 12 Monaten ab dem Lieferdatum des Bootes gilt, danach bis zum Aufbrauchen des Lagerbestandes.

**VOLVO
PENTA**

42200/615001/155099900192

FRE

Envoyez ou faxez le bon de commande à:

Document & Distribution Center
Order Department
ARU2, Dept. 64620
SE-405 08 Göteborg
Suède
Fax: +46 31 545 772

Vous pouvez également passer la commande par Internet:

<http://www.volvopenta.com/manual/coupon>

Oui merci,

Je souhaite recevoir un manuel d'instructions gratuit en français.

Numéro de publication: 7739616

Nom

Adresse

Pays

Notez que l'offre est valable pendant 12 mois à partir de la date de livraison du bateau, ensuite seulement en fonction des stocks disponibles.

**VOLVO
PENTA**

42200/615001/155099900192

SPA

Franquear o enviar fax a:

Document & Distribution Center
Order Department
ARU2, Dept. 64620
SE-405 08 Göteborg
Suecia
Fax: +46 31 545 772

El pedido puede hacerse también por internet:

<http://www.volvopenta.com/manual/coupon>

Sí gracias,

deseo recibir gratuitamente un libro de instrucciones en español.

Número de publicación: 7739617

Nombre

Dirección

País

Nótese que el ofrecimiento vale durante 12 meses después de la fecha de entrega de la embarcación, y posteriormente solamente mientras duren las existencias.

**VOLVO
PENTA**

42200/615001/155099900192

ITA

Spedire il tagliando per posta o per fax a:

Document & Distribution Center
Order Department
ARU2, Dept. 64620
SE-405 08 Göteborg
Svezia
Fax: +46 31 545 772

L'ordinazione può essere fatta anche su Internet:

<http://www.volvopenta.com/manual/coupon>

Sì, grazie,

desidero ricevere gratuitamente un manuale d'istruzioni in lingua italiana.

Public. No.: 7739618

Nome e Cognome

Indirizzo

Paese

Si ricorda che l'offerta è valida per 12 mesi dalla data di consegna dell'imbarcazione; dopo il suddetto periodo l'offerta resta valida solo in base alla disposizione della pubblicazione in oggetto.

**VOLVO
PENTA**

42200/615001/155099900192

SWE

Posta eller faxes kupongen till:

Dokument & Distribution center
Ordermottagningen
ARU2, Avd. 64620
SE-405 08 Göteborg
Sverige
Fax: +46 31 545 772

Beställningen kan även göras via internet:

<http://www.volvopenta.com/manual/coupon>

Ja tack,

jag vill kostnadsfritt ha en instruktionsbok på svenska.

Publikationsnummer: 7739613

Namn

Adress

Land

Observera att erbjudandet gäller i 12 månader från båtens leveransdatum, därefter endast i mån av tillgång.

**VOLVO
PENTA**

42200/615001/155099900192

DUT

Stuur of fax de coupon naar:
Document & Distribution Center
Order Department
ARU2, Dept. 64620
SE-405 08 Göteborg
Zweden
Fax: +46 31 545 772

U kunt ook bestellen via internet:
[http://www.volvopenta.com/
manual/coupon](http://www.volvopenta.com/manual/coupon)

Ja graag,

Ik wil kosteloos een instructieboek in het Nederlands ontvangen.

Publicatienummer: 7739621

Naam

Adres

Land

Denk eraan dat het aanbod geldt gedurende 12 maanden na de datum waarop de boot werd afgeleverd, daarna alleen indien nog verkrijgbaar.

**VOLVO
PENTA**

42200/615001/155099900192

FIN

Postita tai faksaa kuponki osoitteella:
Document & Distribution Center
Order Department
ARU2, Dept. 64620
SE-405 08 Göteborg
Ruotsi
Fax: +46 31 545 772

Tilauksen voi tehdä myös Internetissä:
[http://www.volvopenta.com/
manual/coupon](http://www.volvopenta.com/manual/coupon)

Kyllä kiitos,

haluan suomenkielisen ohjekirjan veloitusetta.

Julkaisunumero: 7739619

Nimi

Osoite

Maa

Huomaa, että tarjous on voimassa 12 kuukautta veneen toimituspäivämäärästä lukien ja sen jälkeen vain niin kauan kuin kirjoja riittää.

**VOLVO
PENTA**

42200/615001/155099900192

POR

Envie o talão pelo correio ou um fax para:
Document & Distribution Center
Order Department
ARU2, Dept. 64620
SE-405 08 Göteborg
Suécia
Fax: +46 31 545 772

A encomenda também pode ser feita através da Internet:
[http://www.volvopenta.com/
manual/coupon](http://www.volvopenta.com/manual/coupon)

Sim, obrigado(a)!

Gostaria de receber gratuitamente um manual de instruções em português.

Número de publicação: 7739622

Nome

Endereço

País

Observar que esta oferta é válida durante um período de 12 meses a contar da data de entrega do barco. Após este período, a oferta está dependente do número de exemplares disponíveis.

**VOLVO
PENTA**

42200/615001/155099900192

GRE

Ταχυδρομήστε αυτό το
κουπόνι στην παρακάτω
διεύθυνση ή στείλτε το με
φαξ στον παρακάτω αριθμό
φαξ:

Document & Distribution Center
Order Department
ARU2, Dept. 64620
SE-405 08 Göteborg
Sweden
Fax: +46 31 545 772

Μπορείτε επίσης να δώσετε
την παραγγελία σας μέσω
του Internet, στη διεύθυνση:
[http://www.volvopenta.com/
manual/coupon](http://www.volvopenta.com/manual/coupon)

Ναι,

Θα ήθελα ένα αντίτυπο του εγχειριδίου χρήσης στην αγγλική γλώσσα χωρίς καμιά χρέωση.

Αριθμός έκδοσης: 7739623

Όνομα

Διεύθυνση

Χώρα

ΠΡΟΣΟΧΗ: Αυτή η προσφορά ισχύει για χρονική περίοδο 12 μηνών από την παράδοση του σκάφους. Μετά το πέρας της εν λόγω χρονικής περιόδου η διαθεσιμότητα των αντιτύπων θα εξαρτάται από την ποσότητα των αποθεμάτων.

**VOLVO
PENTA**

42200/615001/155099900192

RUS

Отправьте этот талон
почтой или факсом на
ИМЯ:

Document & Distribution Center
Order Department
ARU2, Dept. 64620
SE-405 08 Göteborg
Sweden
Fax: +46 31 545 772

Заказы также можно
размещать через Интернет:
[http://www.volvopenta.com/
manual/coupon](http://www.volvopenta.com/manual/coupon)

Да, пожалуйста,

Я бы хотел иметь бесплатное руководство оператора на русском языке.

Номер издания: 7739873

Имя

Адрес

Страна

Примечание: Данное предложение действительно в течение 12 месяцев с момента доставки двигателя. По истечении этого периода наличие товаров будет зависеть от их поступления.

**VOLVO
PENTA**

42200/615001/155099900192

