

SERVICE

SERIAL NUMBER RECORD

Record serial numbers and date of purchase in spaces provided. Serial number plate is mounted on model plate under flaps, as shown.

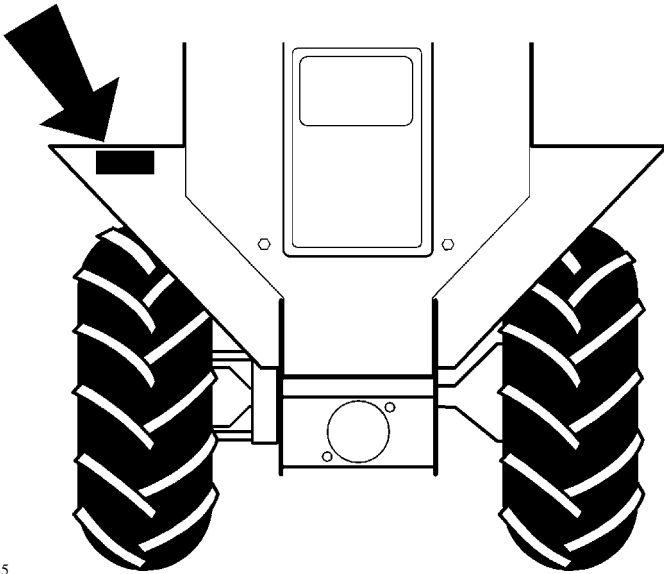

Date of purchase	
Serial number	
Engine serial number	

SUPPORT PROCEDURE

Notify your dealer immediately of any malfunction or failure of Ditch Witch equipment.

Always give model, serial number, and approximate date of equipment purchase. This information should be recorded and placed on file by owner at time of purchase.

Return damaged parts to dealer for inspection and warranty consideration.

Order genuine Ditch Witch replacement parts from your authorized ditch Witch dealer. Use of another manufacturer's parts may void warranty.

RESOURCES

Publications

Contact your Ditch Witch dealer for publications and videos covering safety, operation, service, and repair of your equipment.

Ditch Witch Training

For information about on-site, individualized training, contact your Ditch Witch dealer.

FOREWORD

This manual is an important part of your equipment. It provides safety information and operation instructions to help you use and maintain your Ditch Witch equipment.

Read this manual before using your equipment. Keep it with the equipment at all times for future reference. If you sell your equipment, be sure to give this manual to the new owner.

If you need a replacement copy, contact your Ditch Witch dealer. If you need assistance in locating a dealer, visit our website at **www.ditchwitch.com** or write to the following address:

The Charles Machine Works, Inc.
Attn: Marketing Department
PO Box 66
Perry, OK 73077-0066
USA

The descriptions and specifications in this manual are subject to change. The Charles Machine Works, Inc. reserves the right to improve equipment. Some product improvements may have taken place after this manual was published. For the latest information on Ditch Witch equipment, see your Ditch Witch dealer.

Thank you for buying and using Ditch Witch equipment.

Operator's Manual

1820

Issue Number 5.2/OP-9/04

Part Number 054-485

Copyright 1994, 1995, 2003, 2004
by The Charles Machine Works, Inc.,
Perry, Oklahoma, 73077-0066.

**Ditch
Witch**[®]

, Ditch Witch, CMW, AutoCrowd, Modularmatic, Jet Trac, Roto Witch, Subsite, Fluid Miser, Perma-Soil, Power Pipe, Super Witch, Super Witch II, Pierce Arrow, The Underground, and The Underground Authority Worldwide are registered trademarks of The Charles Machine Works, Inc.

CONTENTS

SERVICE	1
Serial Number Record	1
Support Procedure	2
Resources	2
FOREWORD	3
OVERVIEW	9
CONTROLS	11
Console	11
Descriptions	12
SAFETY	19
Underground Hazards	20
Emergency Procedures	20
Safety Alert Classifications	22
Safety Alerts	23
TRANSPORTATION	29
Lifting	29
Hauling	30
Loading	31
Towing	33

OPERATION	35
Inspect Machine	35
Startup	37
Driving	38
TRENCHING ATTACHMENT	39
Operating Tips	40
DRILLING ATTACHMENT	43
Drilling Attachment Control Descriptions	44
Prepare Jobsite and Equipment	45
Drill	47
Add Rod	49
Backream	49
Disassemble Joints	50
Optional Equipment	50
LUBRICATION	51
Schedule	52
Engine Oil	54
Hydraulic Oil	55
Pivot Tube	57
Trail Wheel Bearing	57
Cross and Bearing	57
Reducer Boxes	58

MAINTENANCE	61
Schedule	62
Fuel	64
Battery	66
Air Filter	68
Cooling System	70
Belts	71
Headshaft Sprocket Bolts	71
Wheels and Tires	71
Trenching Attachment	73
SPECIFICATIONS	77

OVERVIEW

The Ditch Witch 1820 is a self-propelled, walk-along, hydraulically steered, two-wheel drive trencher designed to dig in a variety of soils and move large volumes of dirt in a short time.

With an optional drilling unit attached, it is also designed to drill short distances.

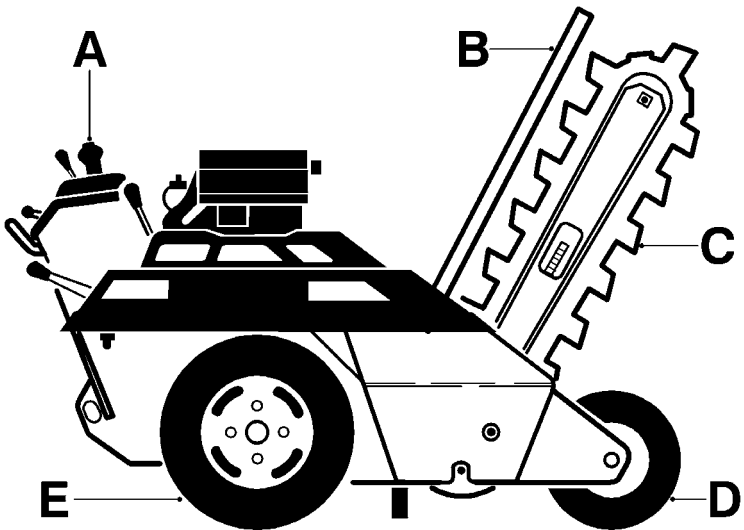

om1641x

- A. Control Panel
- B. Restraint Bar
- C. Digging Chain/Boom
- D. Trail Wheel
- E. Drive Wheel

CONTROLS

CONSOLE

Gasoline Engine

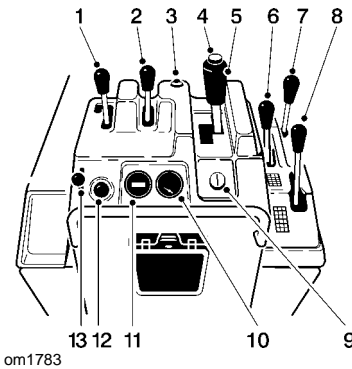

Diesel Engine

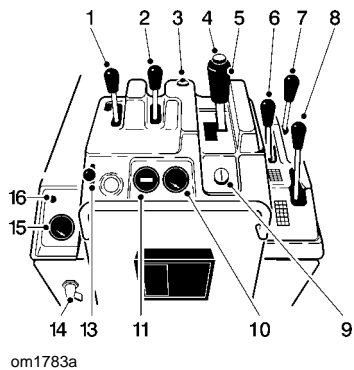

- | | |
|-------------------------------------|---|
| 1. Axle lock (blue) | 9. Ignition switch |
| 2. Boom control (green) | 10. Voltmeter |
| 3. Oil pressure indicator | 11. Hourmeter |
| 4. Operator presence switch (red) | 12. Choke (gas only) |
| 5. Speed/Direction control (orange) | 13. Throttle |
| 6. Hydraulic pump control (orange) | 14. Battery disconnect switch (diesel only) |
| 7. Roto Witch control (optional) | 15. Water temperature gauge (diesel only) |
| 8. Digging chain control (yellow) | 16. Glow plug indicator (diesel only) |

DESCRIPTIONS

Axle Lock (blue)

This lever locks axle (two-wheel drive) or unlocks axle (one-wheel drive).

- Pull to unlock axle. Use unlocked axle to turn trencher.
- Push to lock axle. Use locked axle for straight trenching.

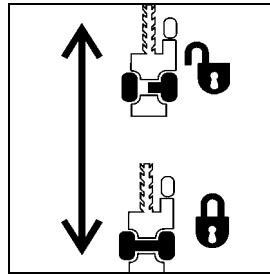

ic1034

Boom Control (green)

This lever raises or lowers digging boom. Can be used only when engine is running.

- Push to lower.
- Pull to raise.

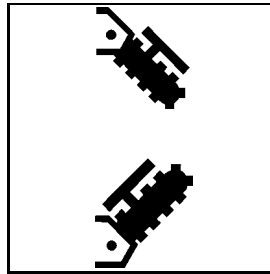

ic1033

Oil Pressure Indicator

This light indicates low oil pressure. Light will come on briefly when engine is started. If light comes on when engine is running:

- Turn engine off.
- Check oil level.
- Check for leaks before starting engine.

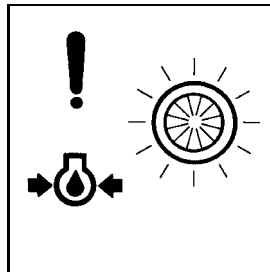

om1008.pcx

Operator Presence Switch (red)

This button prevents machine from running when digging or driving unless operator is pressing switch. Operator presence switch is on top of speed/direction control.

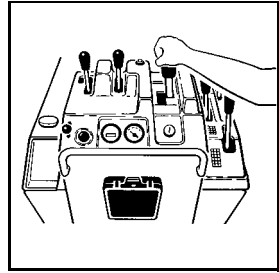

om1014.pcx

Speed/Direction Control (orange)

This lever controls unit speed and direction.

- Push to move toward digging boom.
- Pull to move toward operator position.
- To go faster in either direction, move control farther from center (neutral) position.
- To stop, return to neutral position.
- To turn, move control to left or right while it is in forward, neutral, or reverse position.

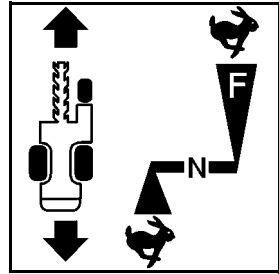

ic0029h

Hydraulic Pump Control (orange)

This lever is used to help start cold engine.

- Push to engage
- Pull to disengage.

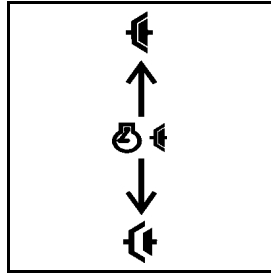

ic1036

Roto Witch Control

This lever controls optional boring attachment. Refer to Roto Witch Operator's Manual for additional information.

- Push to rotate clockwise.
- Pull to rotate counterclockwise.

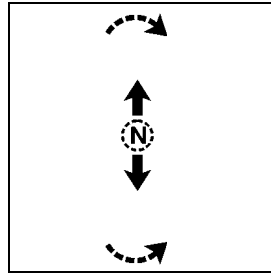

ic1085b

Digging Chain Control (yellow)

This lever controls digging chain action and speed.

- Push to start digging chain.
- Pull to stop digging chain.

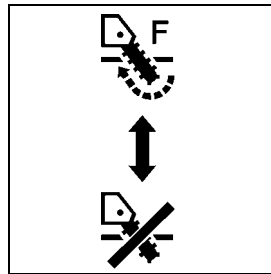

ic1035a

Ignition Switch

This switch is used to start engine.

Gasoline Engines:

- Insert key and turn it clockwise to start position (C).
- When engine starts, release key. It will return to on position (B).
- If engine does not start or is killed, turn switch to off position (A), then restart.

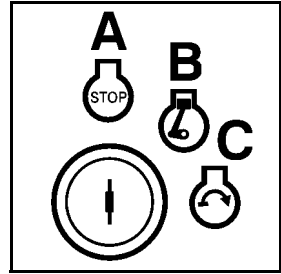

ic1084

Diesel Engines:

- Insert key and turn it clockwise to on position (B). Glow plug indicator will light as engine heats.
- When glow plug indicator goes out, turn key to start position (C).
- When engine starts, release key. It will return to on position (B).
- If engine does not start or is killed, turn switch to off position (A), then restart.

Voltmeter

This gauge measures voltage in electric system. Reading should be between 12 and 15 volts with engine running. If not, stop engine and investigate.

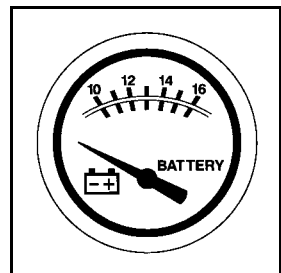

om1132.pcx

Hourmeter

This gauge records operating time. Use to schedule lubrication and maintenance.

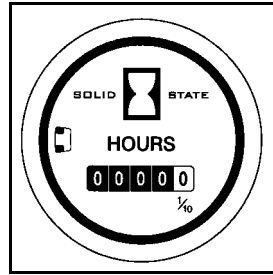

om1132.pcx

Choke (gas only)

This knob helps start cold engine.

- Pull Choke before starting.
- Push Choke in completely when engine has warmed.

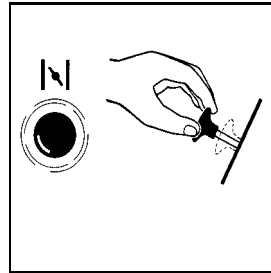

om1011.pcx

Throttle

This lever regulates engine speed.

- Push toward rabbit to increase engine speed.
- Pull toward turtle to slow engine.

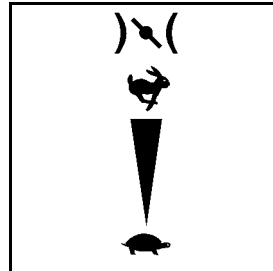

ic1032

Water Temperature Gauge (diesel only)

This gauge displays temperature of water in cooling system.

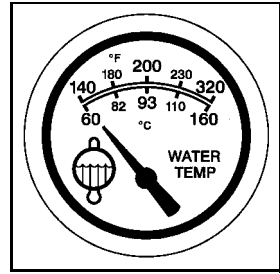

om1463.pcx

Glow Plug Indicator (diesel only)

This indicator lights when glow plug is heating.

NOTICE: Do not turn ignition switch to start until glow plug indicator goes out. For complete starting instructions, see **OPERATION**.

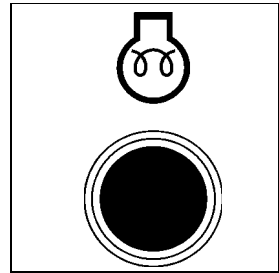

ic0026h

Battery Disconnect

Use for shut-off, when servicing, and during long-term storage.

Battery disconnect is optional on gasoline engines (top illustration) and standard on diesel engines (bottom illustration).

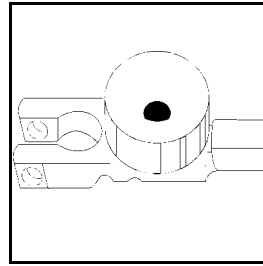

om1749

Gasoline engine:

- Turn clockwise to connect battery power.
- Turn counterclockwise to disconnect battery power.

Diesel engine:

- Turn counterclockwise to connect battery power.
- Turn clockwise to disconnect battery power.

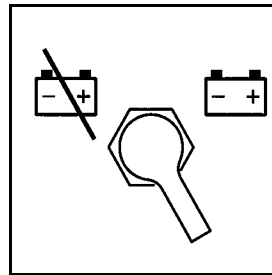

om1486.pcx

SAFETY

Follow these guidelines before operating any jobsite equipment:

- Complete proper training and read operator's manual before using equipment.
- Contact your local One-Call or utility company. Have all underground lines and cables located and marked before operating equipment. If you damage a utility, contact utility company.
- Classify jobsite based on its hazards and use correct equipment, safety equipment, and work methods for jobsite.
- Mark jobsite clearly and keep spectators away.
- Wear personal protective gear.
- Review jobsite hazards, safety and emergency procedures, and individual responsibilities with all personnel before work begins.
- Replace missing or damaged safety shields and safety signs.
- Use equipment carefully. Stop operation and investigate anything that does not look or feel right.
- Contact your Ditch Witch dealer if you have any question about operation, maintenance, or equipment use.



When you see this safety alert sign, carefully read and follow all instructions. **YOUR SAFETY IS AT STAKE.**

UNDERGROUND HAZARDS

Striking underground hazards can cause explosion, electrocution, fire, and exposure to hazardous materials.

Hazards include:

- Electric cables
- Natural gas pipes
- Fiber optic cables
- Water lines
- Sewer lines
- Pipes carrying other chemicals, liquids, or gases
- Storage tanks

EMERGENCY PROCEDURES

If an Electric Line is Damaged

If you suspect an electric line has been damaged and you are **off tractor**, DO NOT TOUCH TRACTOR. Take the following actions. The order and degree of action will depend upon the situation.

- LEAVE AREA.
- Contact utility company to shut off power.
- Do not return to jobsite or allow anyone into area until given permission by utility company.

If a Gas Line is Damaged

If you suspect a gas line has been damaged, take the following actions. The order and degree of action will depend on the situation.

- Immediately shut off engine(s), if this can be done safely and quickly.
- Remove any ignition source(s), if this can be done safely and quickly.
- Warn others that a gas line has been cut and that they should leave the area.
- Leave jobsite as quickly as possible.
- Immediately call your local emergency phone number and utility company.
- If jobsite is along street, stop traffic from driving near jobsite.
- Do not return to jobsite until given permission by emergency personnel and utility company.

If a Fiber Optic Cable is Damaged

Do not look into cut ends of fiber optic or unidentified cable. Vision damage can occur.

If Machine Catches on Fire

Perform emergency shutdown procedure and then take the following actions. The order and degree of action will depend on the situation.

- Immediately move battery disconnect switch (if equipped) to disconnect position.
- If fire is small and fire extinguisher is available, attempt to extinguish fire.

If fire cannot be extinguished, leave area as quickly as possible and contact emergency personnel.

SAFETY ALERT CLASSIFICATIONS

You will see the following safety symbols:



DANGER indicates an imminently hazardous situation which, if not avoided, will result in death or serious injury.



WARNING indicates a potentially hazardous situation which, if not avoided, could result in death or serious injury.



CAUTION indicates a potentially hazardous situation which, if not avoided, may result in minor or moderate injury.

In this book, you should look for two other words: **NOTICE** and **IMPORTANT**.

NOTICE can keep you from doing something that might damage the machine or someone's property. It may also be used to alert against unsafe practices.

IMPORTANT can help you do a better job or make your job easier in some way.

SAFETY ALERTS

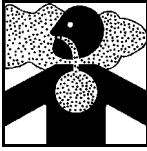

⚠ DANGER

Deadly gases. Lack of oxygen or presence of gas will cause sickness or death. Provide ventilation.

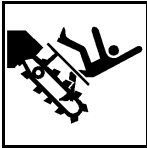

⚠ DANGER

Moving digging teeth will kill you or cut off arm or leg. Stay away.

NOTICE: Keep everyone at least 6' (2 m) away from equipment while operating.

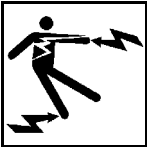

⚠ DANGER

Electrical shock. Contacting electrical lines will cause death or serious injury. Know location of lines and stay away.

**⚠ DANGER**

Turning shaft will kill you or crush arm or leg. Stay away.

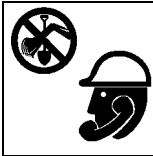
**⚠ WARNING**

Jobsite hazards could cause death or serious injury. Use correct equipment and work methods. Use and maintain proper safety equipment.

NOTICES:

- Do not bore within 10' (3 m) of electric cables or gas pipes.
- Park, unload, and load trailer on level part of jobsite.
- To prevent tipping, connect trailer to tow vehicle before loading or unloading.
- Keep digging boom low when operating on slopes. Drive slowly and cautiously at all times.

**⚠ WARNING**

Crushing weight could cause death or serious injury. Use proper procedures and equipment or stay away.

**⚠ WARNING**

Runaway possible. Machine could run over you or others. Learn how to use all controls. Start and operate only from operator's position.

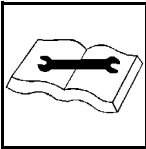
**⚠ WARNING**

Improper control function could cause death or serious injury. If control does not work as described in instructions, stop machine and have it repaired.

NOTICES:

- If interlock system does not work, contact your Ditch Witch dealer. Improper repair may allow machine to start or operate with a control in wrong position.
- Do not wire or tape operator presence switch.

**⚠ WARNING**

Incorrect procedures could result in death, injury, or property damage. Learn to use equipment correctly.

NOTICES:

- Keep attachments low when operating on slope. Drive slowly and cautiously at all times.
- Machine may move when chain starts to dig. Allow 3' (1m) between end of chain and obstacle.
- Digging chain on top side of boom can catch on root or rock. Stand back from console and hold controls loosely.
- Unless otherwise instructed, all service should be performed with engine shut off.
- Refer to engine manufacturer's manual for engine maintenance instructions.
- Before servicing equipment, lower digging boom to ground.

**⚠ WARNING**

Fluid or air under pressure could pierce skin and cause injury or death. Stay away.

NOTICE: Escaping pressurized fluid can cause injury or pierce skin and poison.

- Before disconnecting lines, turn engine off and operate system controls to relieve pressure.
- Before using system, check that all connections are tight and all lines are undamaged.
- Fluid leaks can be hard to detect. Use a piece of cardboard or wood, rather than hands, to search for leaks.
- Wear protective clothing and eye protection.
- If you are injured, seek immediate medical attention from a doctor familiar with this type of injury.

**⚠ CAUTION**

Battery acid may cause burns.
Avoid contact.

**⚠ CAUTION**

Hot parts may cause burns. Do
not touch until cool.

TRANSPORTATION

LIFTING

Lifting Points

Lifting points are identified by lifting decals. Lifting at any other point is unsafe and can damage machinery.

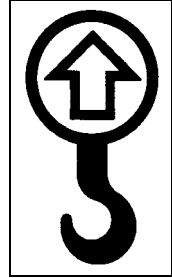

om1362.pcx

Lifting Unit

Before lifting, check **SPECIFICATIONS**. Use a crane capable of supporting the equipment's size and weight.

Lift trencher by running sling through lift points and through trail wheel housing.

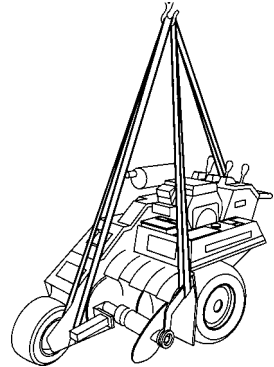

om1362.pcx



WARNING

Crushing weight could cause death or serious injury. Use proper procedures and equipment or stay away.

HAULING

Trencher can be hauled by trailer. Before hauling check the following:

- Check that loading ramps will support weight. See **SPECIFICATIONS**.
- Check that adequate tiedowns are available.

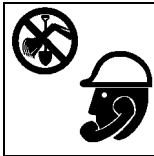
**⚠ WARNING**

Jobsite hazards could cause death or serious injury. Use correct equipment and work methods. Use and maintain proper safety equipment.

NOTICES:

- Park, unload, and load trailer on level part of jobsite.
- To prevent tipping, connect trailer to tow vehicle before loading or unloading.
- Keep digging boom low when operating on slopes. Drive slowly and cautiously at all times.

LOADING

Load Machine

1. Start machine following instructions in **OPERATION**.
2. Push boom control (green) to lower boom as far as possible without hitting ramps.
3. Engage axle lock (blue).
4. Push throttle (black) to 1/2 open.

EMERGENCY STOP: Release operator presence switch.

5. Move speed/direction control (orange) to forward or reverse position.

To turn, move speed/direction control left or right.

6. Align trencher with ramps or trailer, boom first.
7. Guide trencher onto trailer.
8. When tie down position is reached, move speed/direction control (orange) to neutral position.
9. Push boom control (green) to lower boom.
10. Disengage pump control.
11. Pull throttle to turtle.
12. Turn key to off position.
13. Close fuel shut-off valve on gasoline engine.
14. Tiedown trencher to trailer.

Unload Machine

1. Remove tiedowns from trencher.
2. Open fuel shut-off valve on gasoline engine.
3. Start machine.
4. Slowly engage pump control.
5. Move throttle (black) to 1/2 open.
6. Engage axle lock (blue).
7. Pull boom control (green) to raise boom halfway.
8. Use speed/direction control (orange) to slowly back trencher off trailer or down ramps.

TOWING

This trencher is not designed to be towed. If it must be moved without its own power, optional Spare Hub Assembly should be used.

Spare Hub Assembly is designed for temporary use for distances less than 500' (150 m) at slow rate of speed. Assembly should only be used for towing.

Spare hub assembly is stored near right drive tire, under guard.

Optional Spare Hub Assembly

1. Remove guard covering assembly.
2. Remove two mounting bolts and remove assembly from storage position.
3. Securely block right side of trencher. Right wheel should be off ground.

IMPORTANT: On diesel units, right tire and wheel assembly is filled with tire ballast and weighs approximately 127 lb (58 kg).

4. Remove right wheel.
5. Place assembly on lug bolts and attach with lug nuts. If wrench will not fit through access holes, remove snap ring and outer flange, tighten lug nuts, and replace flange and snap ring.
6. Remove lug nuts from spare hub assembly bolts.
7. Place right wheel on assembly.
8. Securely fasten wheel with lug nuts.
9. Lower trencher.
10. Push axle lock to disengage. Machine will freewheel.
11. Slowly tow trencher.

OPERATION

INSPECT MACHINE

For safe and efficient use of your machine, check the following before each day's work. Refer to **LUBRICATION** and **MAINTENANCE** for additional information.

- General appearance.
- Condition of digging chain, teeth, drive belts, and air filter.
- Fuel lines and fittings for signs of leakage, wear, or other damage.
- Tire pressure. Use reliable tire pressure gauge.
- Engine oil level. Keep oil level at highest line on dipstick.
- Hydraulic oil level. Keep oil level between high and low marks on dipstick.
- Fuel level. Fill tank at end of day to reduce condensation.
- Water level in diesel units. Keep overflow bottle 1/4 to 3/4 full. Add antifreeze as needed.
- Signs are in place and readable.
- Guards and shields are in place.
- Nuts and bolts are tight. Tighten as specified in torque tables in **PARTS MANUAL**.

START-UP

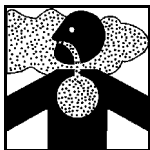
**⚠ DANGER**

Deadly gases. Lack of oxygen or presence of gas will cause sickness or death. Provide ventilation.

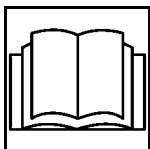
**⚠ WARNING**

Incorrect procedures could result in death, injury, or property damage. Learn to use equipment correctly.

IMPORTANT: Read engine manufacturer's starting and operating instructions. Follow directions for new engine break-in.

1. Disengage pump control (orange).
2. Check that speed/direction control (orange) is in neutral position.
3. Check that digging chain control (yellow) is at stop position.
4. Open fuel shut-off valve on gasoline engine.
5. Push throttle (black) to 1/4 open.

6. Start engine. If engine does not start within ten seconds, release key, allow starter motor to cool, and try to start again. If engine does not start after three tries, check machine.

Gasoline Engine:

Choke cold engine. Put key in ignition and turn to start position. When engine starts, release key. Push choke in.

Diesel Engine:

Put key in ignition and turn to on position until glow plug indicator goes out. Turn key to start position. When engine starts, release key.

7. Engage pump control (orange) slowly.
8. Idle engine 3-5 minutes before moving. Engine will idle with digging chain disengaged and speed/direction control in neutral position.
9. Check controls for correct operation.

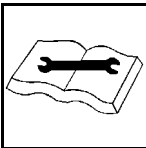
**⚠ WARNING**

Improper control function could cause death or serious injury. If control does not work as described in instructions, stop machine and have it repaired.

NOTICES:

- If interlock system does not work, contact Ditch Witch dealer. Improper repair may allow machine to start or operate with a control in wrong position.
- Do not wire or tape operator presence switch.

DRIVE

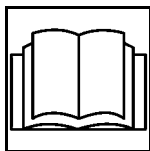
**⚠ WARNING**

Incorrect procedures could result in death, injury, or property damage. Learn to use equipment correctly.

NOTICE: Keep attachments low when operating on slope. Drive slowly and cautiously at all times.

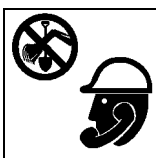
**⚠ WARNING**

Jobsite hazards could cause death or serious injury. Use correct equipment and work methods. Use and maintain proper safety equipment.

IMPORTANT: Keep hand on operator presence switch or machine will not run.

1. Raise or lower boom.
 - Pull boom control (green) to raise boom.
 - In rough terrain, push boom control (green) to lower boom for better stability.
2. Engage or disengage axle lock.
 - On level ground, pull axle lock (blue) to disengage.
 - In rough terrain, push axle lock (blue) to engage.
3. Push throttle (black) to 3/4 open.
4. Depress operator presence switch and move speed/direction control (orange) to forward or reverse position.
5. To turn move speed/direction control (orange) to left or right.

TRENCHING ATTACHMENT

1. Move trencher to starting point.
2. Move speed/direction control to neutral position.
3. Push axle lock (blue) to engage.
4. Push throttle (black) to 1/2 open.
5. Push boom control (green) until boom is 1" (25 mm) from ground.

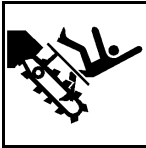

⚠ DANGER

Moving digging teeth will kill you or cut off arm or leg. Stay away.

NOTICE: Keep everyone at least 6' (2 m) away from equipment while operating.

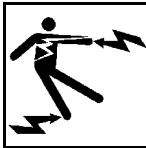

⚠ DANGER

Electrical shock. Contacting electrical lines will cause death or serious injury. Know location of lines and stay away.



⚠ WARNING Jobsite hazards could cause death or serious injury. Use correct equipment and work methods. Use and maintain proper safety equipment.

NOTICES:

- Do not dig within 10' (3 m) of electric cables or gas pipes.
 - Keep digging boom low when operating on slopes. Drive slowly and cautiously at all times.
6. Push digging chain control to start digging chain.
 7. Push boom control (green) slowly to lower digging chain to trench depth.

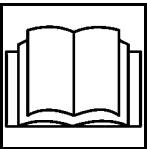

⚠ WARNING Incorrect procedures could result in death, injury, or property damage. Learn to use equipment correctly.

NOTICES:

- Machine will lurch when chain starts to dig. Allow 3' (1 m) between end of chain and obstacle.
- Digging chain on top side of boom can catch on root or rock. Stand back from console and hold controls loosely.

8. When trench depth is reached, push throttle (black) to increase engine speed.
9. Pull speed/direction control (orange). Trencher will move toward you.

Trenching movement is toward you.

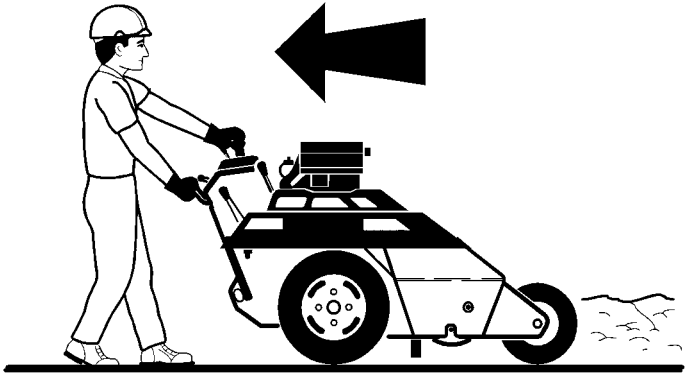

om1642

10. When trench is finished, move speed/direction control (orange) to neutral position.
11. Pull throttle (black) to 1/2 open.
12. Raise boom (green) to top of trench.
13. Pull digging chain control (yellow) to stop position.
14. Raise boom (green) completely.
15. Use speed/direction control (orange) to move trencher away from trench. Let engine idle a few minutes to cool, then turn ignition off.

OPERATING TIPS

- Avoid digging with badly worn digging teeth. When replacing old teeth, maintain original tooth pattern. Use Ditch Witch replacement teeth for best trenching results.
- Operate engine at full throttle under load for most productive trenching. If soil conditions permit, operating in this range gives longer engine life and more efficient use of available engine horsepower.
- Use slower digging chain speed in hard soil. Use alligator chain in frozen or rocky soil.
- When beginning trench near a wall or fence, allow enough distance between boom and footings, drains, and cables.
- Use correct digging boom length. Shortest turn may be made with boom fully down.
- When cutting across asphalt roads, start trench in soil at edge of road and dig with shortest possible boom at full digging depth.
- For a clean trench floor, use optional trench cleaner.
- When straight trenching across a slope, it can be helpful to stake 4x4" wood beam parallel to intended course and just far enough from trench to guide downslope wheel.
- Trenching a straight line is easier with wheels turned slightly to auger side of machine.

DRILLING ATTACHMENT



⚠ DANGER Turning shaft will kill you or crush arm or leg. Stay away.

NOTICE: Keep everybody at least 10' (3 m) away from drill pipe during operation. Do not straddle trench or drill pipe while drilling.

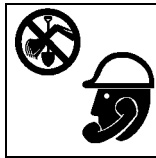

⚠ WARNING Jobsite hazards could cause death or serious injury. Use correct equipment and work methods. Use and maintain proper safety equipment.

NOTICE: Set up warning barriers and keep people away from equipment and jobsite while drilling.

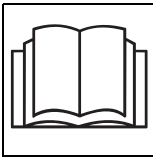

⚠ WARNING Incorrect procedures could result in death, injury, or property damage. Learn to use equipment correctly.

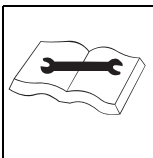

⚠ WARNING Improper control function could cause death or serious injury. If control does not work as described in instructions, stop machine and have it serviced.

NOTICE: Do not tape or tie down switch or lever.

DRILLING ATTACHMENT CONTROL DESCRIPTION

Drilling Control

This switch controls drill string rotation.

- To rotate clockwise, press top.
- To rotate counterclockwise, press bottom.

IMPORTANT: Always rotate clockwise during drilling and backreaming. Rotate counterclockwise only to dislodge a dry bore bit or reamer that has siezed in the bore hole.

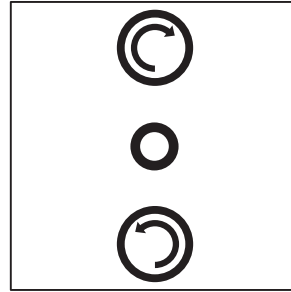

c00ic084a.eps

IMPORTANT:

- This switch is spring-loaded and will automatically stop the drilling attachment when released.
- If using only remote handle, switch will not be mounted on dash.

PREPARE JOBSITE AND EQUIPMENT

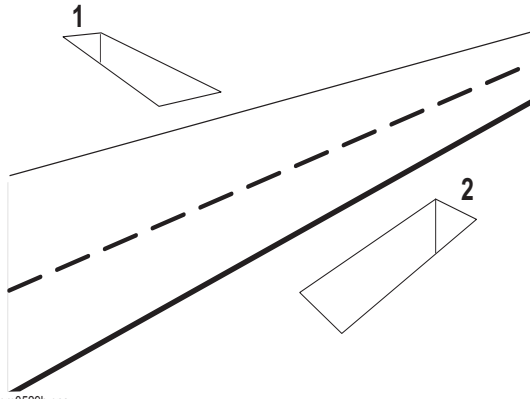

Approach Trench (1)

1. Mark path where you intend to drill.
2. Dig an approach trench (1) along the intended drill path.

IMPORTANT: The approach trench should be at least:

- deep enough for pipe to lay flat and enter soil at correct angle
- 20' (6 m) long
- 4" (100 mm) wide

Target Trench (2)

1. Select a completion point for the drilling project.
2. Dig a target trench (2) **across** the anticipated completion point.

IMPORTANT: The actual length of the target trench depends on soil conditions and length of pipe sections. Make it deep enough for drill bit to enter slightly above the trench floor.

Drill Pipe and Equipment

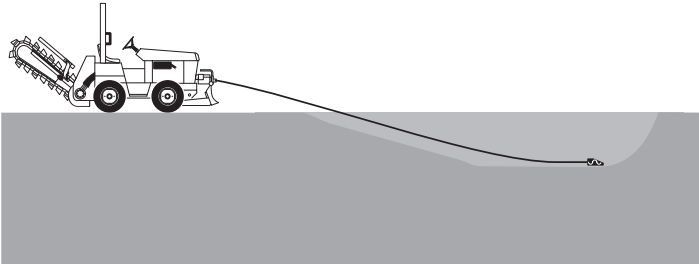

om0540h.eps

1. Assemble at least 20' (6 m), but not more than 30' (9 m), of drill rod.

NOTICE: More than 10-15' (3-4.5 m) of drill rod out of the trench increases the tendency of drill rod to bend.

2. Install drill bit to the cutting end of the drill string.
3. Put drill string in approach trench.
4. Move tractor to the approach trench and align the drilling attachment with the intended bore path.
5. Turn off engine.
6. Attach drill string to drilling attachment.

DRILL

EMERGENCY SHUTDOWN: Release drilling control and turn ignition switch to STOP.

1. Start tractor's engine and begin clockwise (forward) rotation.
2. Slowly advance tractor while maintaining clockwise rotation.

NOTICE:

- Drilling too quickly causes bit to drift off course and may bend drill rod. After drill path is established, speed may be slightly increased.
- If drill rod starts to bend, stop forward movement of unit and back the unit slightly until rod straightens. Do not drill with bent rod.
- If drill rod hits an obstruction, rotate drill string counterclockwise to back up slightly.

Using Drill String Guide



⚠ DANGER Turning shaft will kill you or crush arm or leg. Stay away.

NOTICE: Keep everybody at least 10' (3 m) away from drill rod during operation. Do not straddle trench or drill rod while drilling.

Use drill string guide to align drill string as it enters the soil. When using drill string guide, follow these guidelines:

- Use only approved Ditch Witch drill string guide (p/n 179-737).
- Stand only on the **left** side of the approach trench.
- Keep drill string guide at least 3' (1 m) behind bit.
- Use drill string guide to control only the first 5' (1.5 m) of the bore path.
- After drilling 5' (1.5 m), stop unit and remove drill string guide.
- **Do not** use drill string guide during backreaming or any time the drill string is being pulled back.

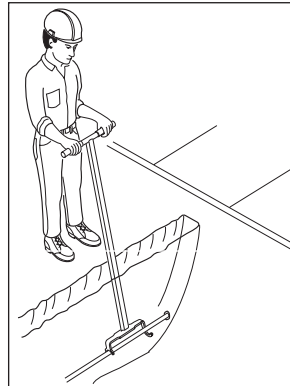

om0342c.eps

ADD ROD

1. Stop drilling attachment.
2. Back up tractor 6" (150 mm) to loosen drill rod in ground.
3. Disconnect drill rod from drilling attachment.
4. Move tractor away from bore.
5. Add one drill rod to continue bore.

BACKREAM

After drill bit enters target trench, the bore hole may be enlarged by changing the drill bit to a backreamer and drawing it back through the initial bore.

1. Turn tractor ignition switch to STOP.
2. Replace drill bit with backreamer.
3. Start tractor engine and begin clockwise rotation.

IMPORTANT: Always rotate clockwise during backreaming. Rotate counterclockwise only to dislodge a dry bore bit or reamer that has siezed in the bore hole.

4. Slowly back up tractor while maintaining rotation.
5. When backreamer exits the bore hole, stop rotation immediately.

IMPORTANT:

- Do not try to increase hole size too much in one pass. Several passes using successively larger reamers will save wear on machine.
- During backreaming, keep drill string straight. Sharp bends in the drill rod at the motor coupling can cause rod failure.

DISASSEMBLE JOINTS

1. Press tab through hole in female side of joint using special tool or screwdriver.

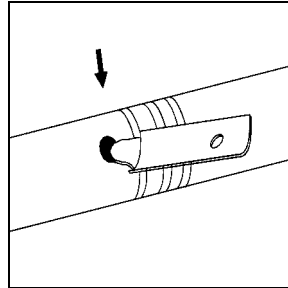

2. Pull rods apart.

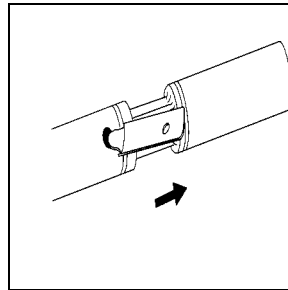

OPTIONAL EQUIPMENT

Drill Rod

Bent or damaged drill rod might break when being pushed. Replacement drill rod and connectors are available through your Ditch Witch dealer.

Bits and Backreamers

Bits and backreamers are available in a variety of sizes and types to match jobsite needs. Contact your Ditch Witch dealer for more information.

LUBRICATION

Proper lubrication and maintenance protects Ditch Witch equipment from damage and failure.

Use only recommended lubricants. Fill to capacities listed in **SPECIFICATIONS**.

Recommended Lubricants	
AGMA-7	Worm gear lubricant matching American Gear Manufacturer's Association Compound #7
GEO	Gasoline Engine Oil meeting API service classification SD
DEO	Diesel Engine Oil (SAE 10W40) meeting API engine service classification SF/CD or CE
MPG	Multipurpose grease
MPL	Multipurpose lubricant 80W90
THF	Tractor hydraulic fluid, similar to Phillips 66 HG, Mobilfluid 432, Chevron tractor hydraulic fluid, Texaco TDH oil, or equivalent

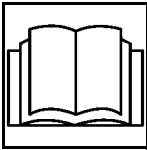

⚠ WARNING





Incorrect procedures could result in death, injury, or property damage. Learn to use equipment correctly.

NOTICES:

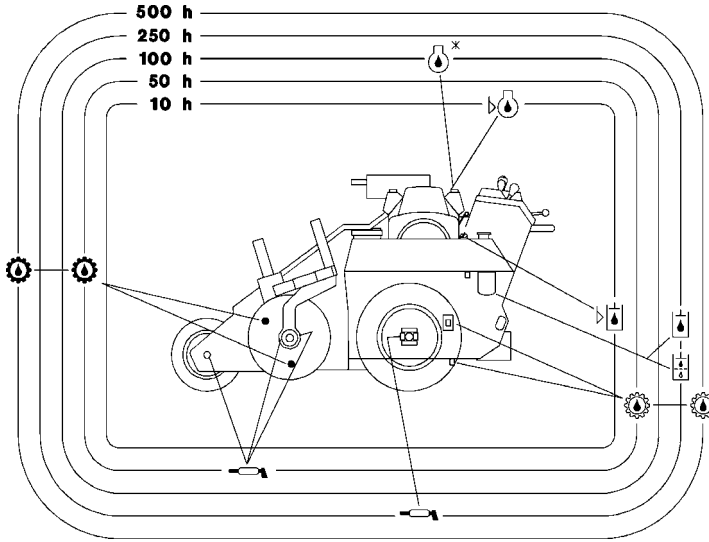
- Unless otherwise instructed, all service should be performed with engine shut off.
- Refer to engine manufacturer's manual for engine maintenance instructions.
- Before servicing equipment, lower digging boom to ground.

LUBRICATION SCHEDULE



	Gasoline engine oil Diesel engine oil
	Multipurpose lubricant (MPL) 80W90
	Multipurpose lubricant (AGMA-7)
	Multipurpose grease
	Tractor hydraulic fluid (THF)

Interval	Task	Page
10 hours	Check engine oil	54
	Check hydraulic oil	55
20 hours	Change engine oil (initial)	54
50 hours	Lube pivot tube	57
	Lube trail wheel	57
	Check axle reducer box oil	58
	Change axle reducer box (initial)	58
	Change headshaft reducer box (initial)	59
75 hours	Change engine oil and filter (diesel)	54
100 hours	Change engine oil and filter (gas)	54
250 hours	Change hydraulic oil and filter	55
	Lube cross and bearings	57
500 hours	Change axle reducer box	58
	Change headshaft reducer box	59

ENGINE OIL

Check Oil

Honda engine:

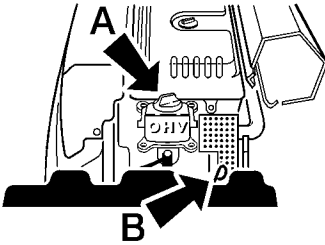

om1665a

Kubota engine:

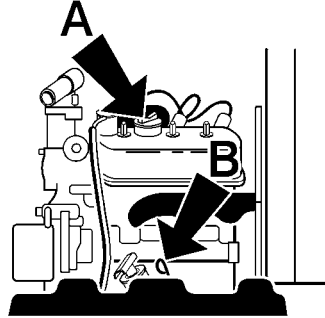

om0046h

Check engine oil every 10 hours. Maintain engine oil level at full mark on dipstick. Use GEO in Kohler or Honda engine; use DEO in Kubota engine.

- Check at dipstick (B).
- Add oil at fill (A).

Change Oil

Change engine oil after first 20 hours of operation, then every 100 hours (gasoline engines) or 75 hours (diesel engine). Drain is under left fender behind tire.

Change Filter

Change engine oil filter each time engine oil is changed.

HYDRAULIC OIL

Check Hydraulic Oil

Check hydraulic oil every 10 hours.

- Raise boom fully and turn rear wheels to the left (D).
- Clean cap and tube before removing dipstick (A).
- Refill to full mark with THF.

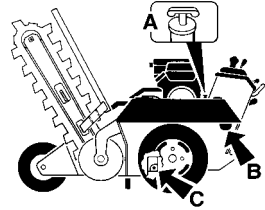

om1033.pcx

Change Hydraulic Oil and Filter

Change hydraulic oil and filter every 250 hours.

- Drain at plug (C).
- Fill with 5.5 gal (21 L) THF at dipstick (A).
- Replace hydraulic oil filter (B).

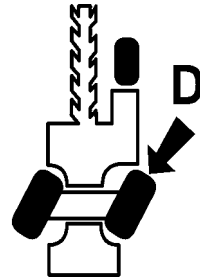

om1670

**⚠ WARNING**

Fluid or air under pressure could pierce skin and cause injury or death. Stay away.

NOTICE: Escaping pressurized fluid can cause injury or pierce skin and poison.

- Before disconnecting lines, turn engine off and operate system controls to relieve pressure.
- Before using system, check that all connections are tight and all lines are undamaged.
- Fluid leaks can be hard to detect. Use a piece of cardboard or wood, rather than hands, to search for leaks.
- Wear protective clothing and eye protection.

PIVOT TUBE

Lube two pivot tube zerks near base of digging chain every 50 hours with MPG.

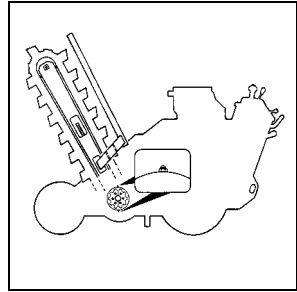

om1037.pcx

TRAIL WHEEL BEARING

Lube each trail wheel bearing every 50 hours with MPG.

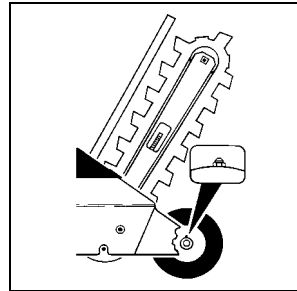

om1038.pcx

CROSS AND BEARINGS

Lube cross and bearing every 250 hours with MPG.

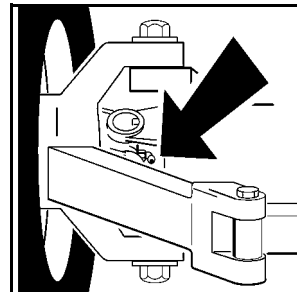

om1666

REDUCER BOXES

Axle Reducer Box

Check axle reducer box oil every 50 hours.

Change axle reducer box oil after first 50 hours of operation and then every 500 hours.

- Turn tires fully to left.
- Remove fill plug (A) through access hole.
- Remove drain plug (B).
- When drained, clean and replace plug.
- Refill with 2.5 pints (1.2 L) AGMA-7.

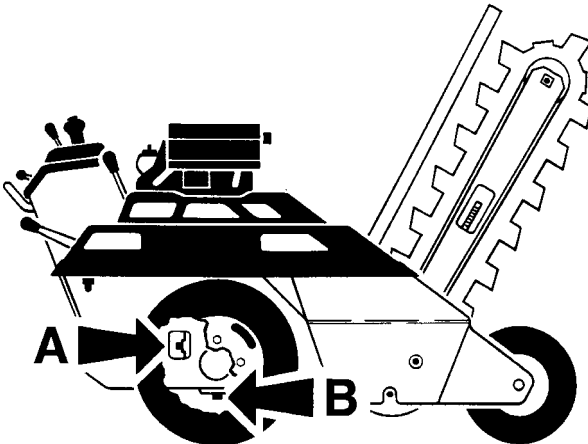

Headshaft Reducer Box

Check headshaft reducer box oil after every 500 hours.

Change headshaft reducer box oil after first 50 hours of operation and then every 500 hours.

- Remove gear box fill plug (B) through access hole. Oil should be at bottom of fill opening threads.
- Drain at plug (A).
- Refill gear box with 2.5 pint (1.2 L) MPL.
- Do not overfill.

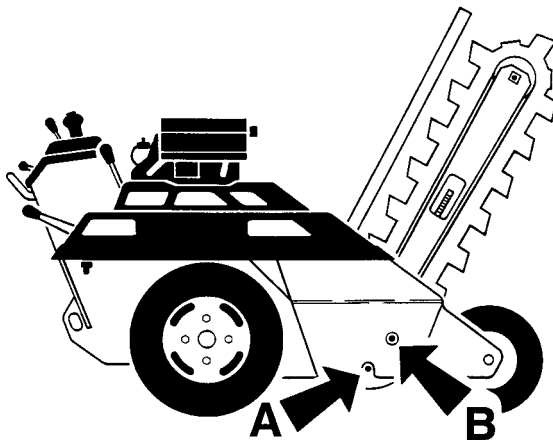

om1039.pcx

MAINTENANCE

See **ENGINE MANUFACTURER'S GUIDE** for further maintenance instructions.



⚠ WARNING

Incorrect procedures could result in death, injury, or property damage. Learn to use equipment correctly.

NOTICES:

- Unless otherwise instructed, all service should be performed with engine shut off.
- Before servicing equipment, lower digging boom to ground.

SCHEDULE

Gasoline Engine:

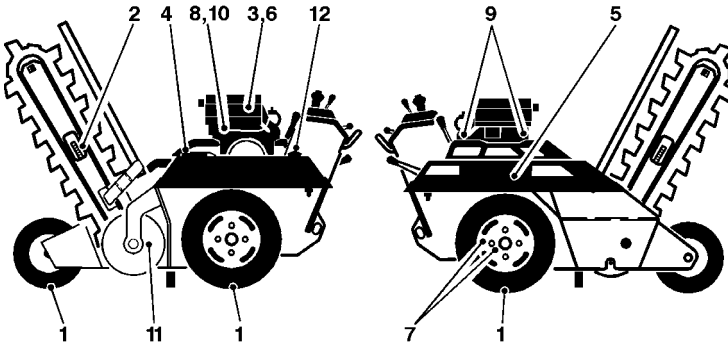

om1015

Diesel Engine:

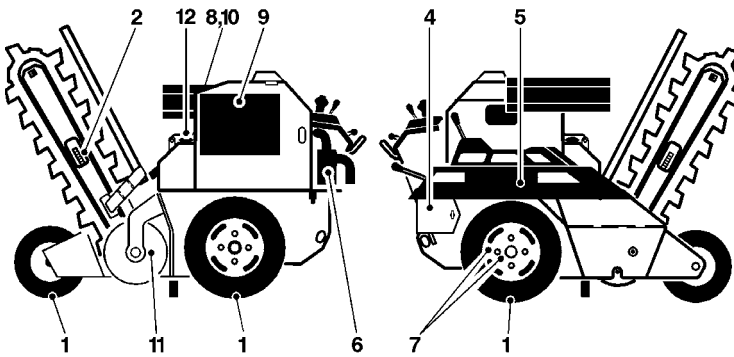

om1015a

Hours	Ref.	Task	Page
10	1	Check tire pressure	72
	2	Adjust digging chain tension	73
25	3	Wash and oil air filter precleaner	68
50	4	Check battery	66
	5	Check belt tension	71
100	6	Replace air filter paper element and precleaner (gas only)	68
	7	Check drive wheel end play and lug nuts	72
	8	Check fuel filter	65
	9	Check cooling fins	70
200	10	Replace fuel filter	65
500	5	Change belts	71
2000	9	Change coolant (diesel only)	70
	4	Change battery	67
As needed	11	Torque headshaft sprocket bolts	71
	12	Check fuel level	64

FUEL

Level

Check fuel level each use.

Gasoline engine: Use high-quality unleaded gasoline only.

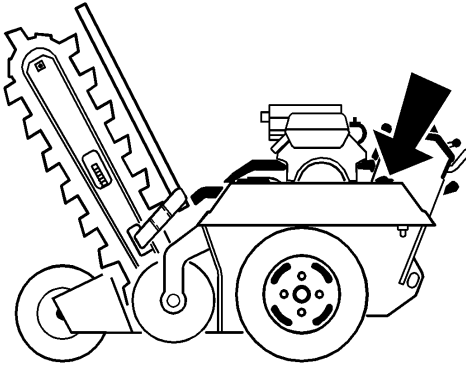

om0050h

Diesel engine: Use number 2 diesel only.

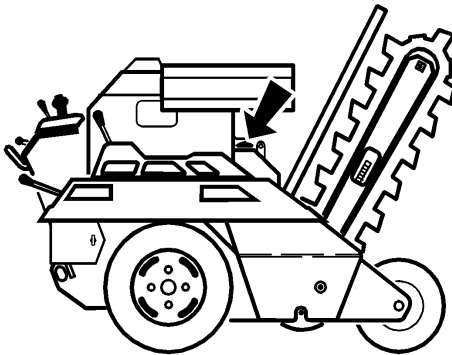

om0045

Filter

Check fuel filter for blockage every 100 hours. Replace blocked filters.

Replace fuel filter every 200 hours.

Gasoline engine:



om0049h

Diesel engine:

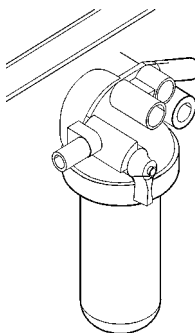

om0041h

BATTERY

**⚠ CAUTION**

Avoid contact.

Battery acid may cause burns.

**⚠ WARNING**

touch until cool.

Hot parts may cause burns. Do not

Check

Check battery fluid level every 50 hours. Fill cavity with enough distilled water to cover plates. Do not overfill.

Keep battery case and terminals clean. Remove corrosion from terminals with wire brush. Wash terminals with baking soda and water solution. Apply coat of grease to cable clamps after cleaning.

Charge

In cold weather, check battery charge frequently. If water is added during freezing weather, charge battery immediately.

If battery will not hold charge, replace with one meeting requirements listed in **SPECIFICATIONS**.

Change

Replace battery every 2000 hours.

Gasoline engine:

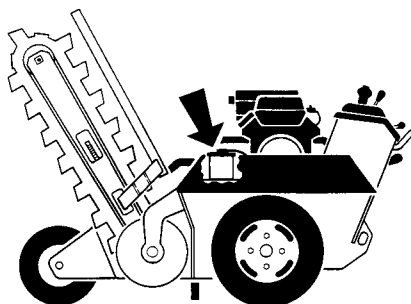

om1018.pcx

Diesel engine:

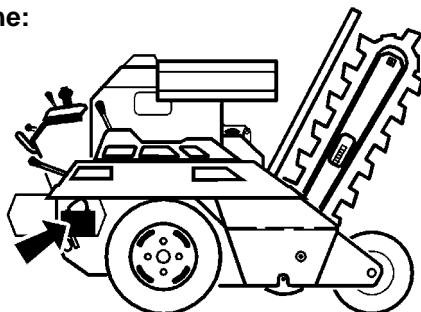

om0044h

AIR FILTER

Gasoline Engine

Clean every 25 hours.

- Clean and oil air filter precleaner.
- Clean paper element.
- Clean inside of air filter housing with damp cloth and allow to dry.
- Inspect parts and tighten or replace if necessary.

Replace air filter precleaner and paper element every 100 hours.

1. Foam rubber precleaner
2. Machine screws
3. Rubber gasket
4. Paper air filter element
5. Rubber gasket
6. Cover
7. Wing bolt

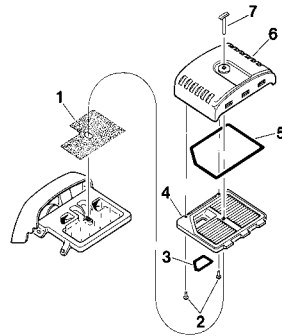

om1012.pcx

Diesel Engine

Clean every 100 hours.

- Wipe clean. Use compressed air to clean element.
- Inspect filter.

Replace every 1000 hours or every six cleanings.

1. Housing.
2. Bottom cup
3. Baffle
4. Element

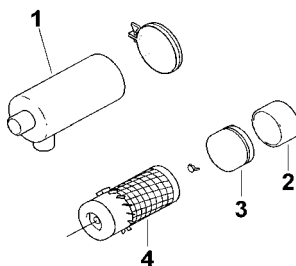

om0000c

COOLING SYSTEM

Cooling Fins

Clean cooling fins on cylinder head and barrel every 100 hours. On diesel engines, check radiator for dirt in fins.

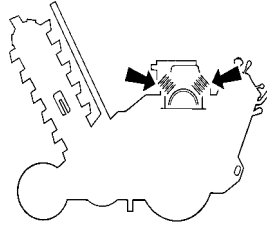

om1022.pcx

Radiator (Diesel engine)

Change coolant every 2000 hours. Check at overflow tank (2). Drain at plug (3). Fill with antifreeze or coolant at fill (1) until tank is full and overflow tank to half-full.

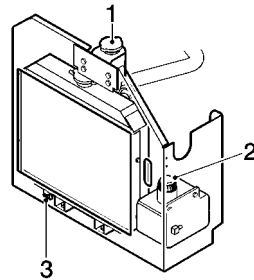

om0042h

BELTS

Check belts for wear and proper tension every 50 hours. Do not overtighten. Keep oils, grease, and fuel off belts.

Check belts by measuring tension springs. With axle lock engaged, spring A should be 3.2" (8 cm) and spring B should be 5" (13 cm). Tighten nuts to adjust springs.

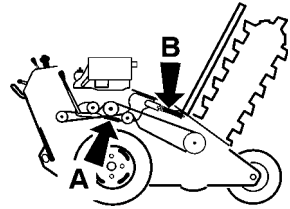

om1668

HEADSHAFT SPROCKET BOLTS

Torque headshaft sprocket bolts to 50 ft•lb (68 N•m) every 200 hours.

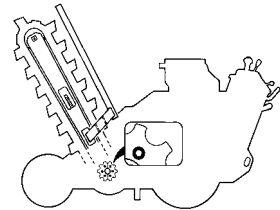

om1668

WHEELS AND TIRES

Tire Pressure

Check tires with gauge before operating machine.

- Drive tires (A) recommended maximum pressure is 22 psi (1.5 bar).
- Trail tire (B) recommended pressure is 32 psi (2.2 bar).

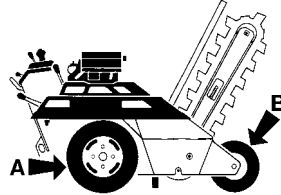

om1016.pcx

Drive Wheels

Check for loose drive wheels every 100 hours.

- Block wheels.
- Shake drive wheels.
- If loose, remove roll pin (C) and tighten castle nut (A). Do not overtighten; wheels should turn smoothly.
- Replace roll pin (C).
- Torque lug nuts (B) to 85 ft•lb (115 N•m).

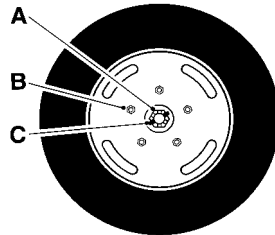

om1024.pcx

TRENCHING ATTACHMENT

Chain Wear

Replace worn or broken chains. If sidebars are bending or getting loose on chain pins, chain spacers should be used to join sidebars.

Digging Chain

Visually check digging chains for wear on rollers and sidebars. Check pins and bushing wear by measuring distance between chain pins and comparing it to new chain.

Replace sprockets when new chain is installed.

To remove digging chain:

1. Start unit, following directions in **OPERATION** section.
2. Turn digging chain until connector pin is on top of boom.
3. Lower boom to ground.
4. Stop engine.
5. Secure chain.

Sprocket booms - Lock rear idler sprocket.

Roller booms - Clamp links on either side of connector pin with chain jaws. Squeeze jaws to reduce pressure on connector pin.

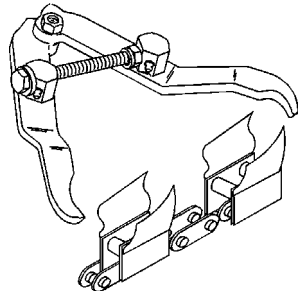

om1752

6. Loop cable through links nearest connector pin.

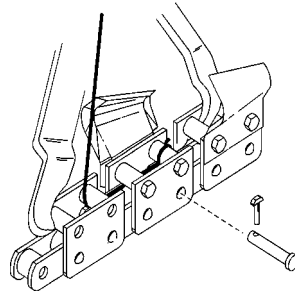

om1744

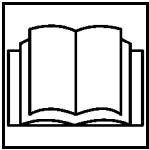
**⚠ WARNING**

Incorrect procedures could result in death, injury, or property damage. Learn how to use equipment correctly.

7. Turn tension bolts counterclockwise to release tension on digging chain.
8. Stand clear of chain. Do not stand behind boom. Keep feet from under boom.
9. Remove pin from connector pin and drive pin out of link.
10. Unclamp links (roller boom). Slowly release cable and lower chain to ground.

To install digging chain:

1. Lay digging chain on ground with teeth down and pointed toward unit. Loop cable through end links.
2. Start unit.
3. Back unit up until digging chain extends past headshaft about one foot.
4. Lower boom to horizontal position.
5. Stop engine.
6. Secure chain on sprocket booms by locking rear idler sprocket.
7. Pull rear end of chain over tail sprocket or roller. Pull cable until chain is in place on boom.
8. Attach chain jaws to end links and bring links into place.
9. Install connector pin and lock key.

10. Tighten digging chain.

Sprocket Booms

Digging chain tension is correct when 1-1.5" (25-40 mm) slide and stop (C) is exposed. Adjust boom tension by tightening or loosening adjustment screws (B) and jam nuts (A).

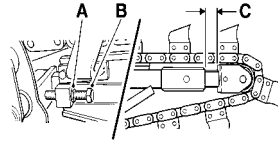

om1031.pcx

Roller Booms

With boom horizontal, measure distance from bottom of boom to chain (C). When properly adjusted, distance should be 1" (25 mm). Adjust boom tension by tightening or loosening adjustment screw (A) and jam nut (B).

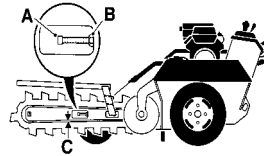

om1017.pcx

Digging Teeth

Digging teeth should be replaced with new Ditch Witch teeth. When replacing teeth, maintain original tooth pattern.

Each unit is equipped with a standard tooth configuration. Depending on soil conditions and type of chain, a different configuration might produce better results. Contact your authorized Ditch Witch dealer for more information about digging teeth patterns.

Alligator chain bits, like teeth, wear out. When tungsten cap or insert is gone, bit will wear quickly. Replace it before bit adapter is damaged.

Bits must rotate freely in bit holders. Clean chain and check bits for free rotation after each use. If any bit does not rotate, it will wear unevenly and quickly.

SPECIFICATIONS

Gasoline Engine

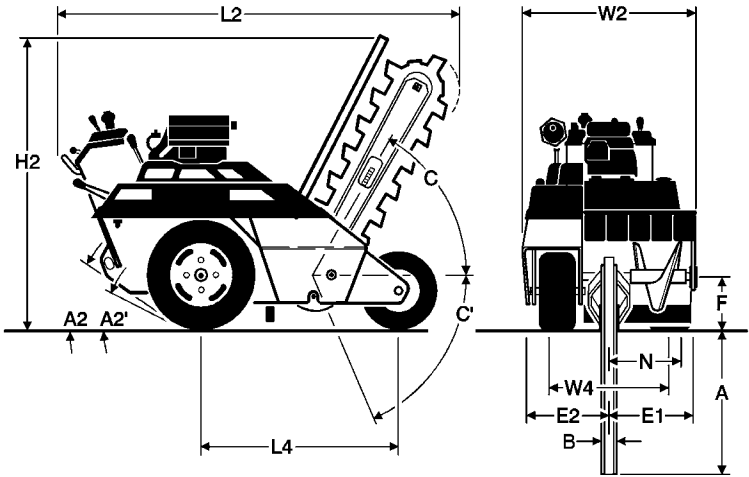

om2292

Diesel Engine

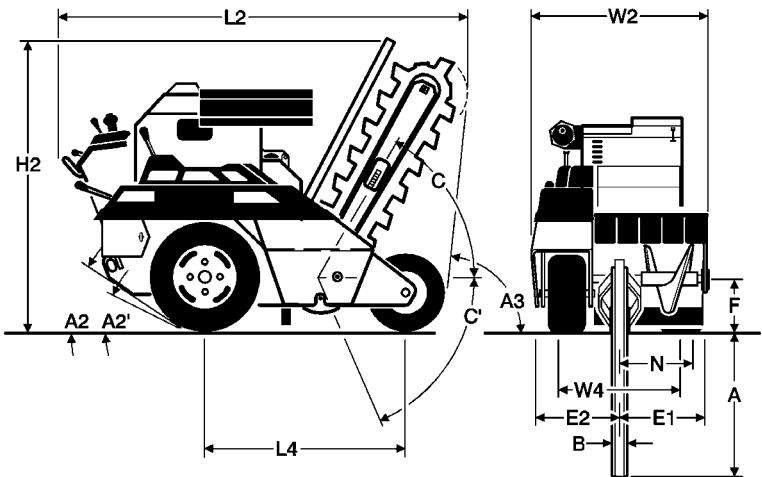

om0047h.tif

DIMENSIONS*:		U.S.	METRIC
A	Trench depth	48 in	1.2 m
B	Trench width	3.25-16 in	85-405 mm
C	Boom travel up	60°	60°
C'	Boom travel down	60°	60°
F	Headshaft height	11 in	280 mm
L	Length-transport	81 in	2.6 m
W	Width-transport	35.6 in	905 mm
H	Height-transport**	63 in	1.6 m
	Kubota	66.5in	
W	Tread	27 in	685 mm
A	Angle of departure	84°	84°
L	Wheelbase	43 in	1090 mm
E	Centerline trench to outside edge machine, left	16.25 in	415 mm
E	Centerline trench to outside edge machine, right	19.3 in	90 mm
A	Angle of approach	32°	32°
A'	Angle of approach w/boring attachment	17°	17°
	Spoil discharge reach	13.2 in	335 mm
*Dimensions are based on narrow tread and 8" (203 mm) pivot and gas engine.			
**Standard boom: refer to chart for recommended depth/width combinations.			

GENERAL:

Ditch Witch Model 1820, self-propelled, non-riding, hydraulically steered, two-wheel drive, rigid frame, chain-type trencher.

OPERATION:		U.S.	METRIC
Vehicle speeds			
	Maximum transit forward	142 fpm	43 m/min
	Maximum transit reverse	86 fpm	26 m/min
Digging chain speed @ 207 rpm		290 fpm	88 m/min
Tire steering angle			
	Inside tire	28.5°	28.5°
	Outside tire	23°	23°
Vehicle clearance circle (SAE)		20.7 ft	6.3 m
Spoil handling			
	Auger-type	Single, open end	
	Auger-size	18.75 in OD x 1.5 in ID x 11.5 in long	476 mm OD x 40 mm ID x 290 mm long
	Trench cleaner type	Mechanical	
	Trench cleaner size	4 - 16 in	100-405 mm
Operating weight (based on roller boom and narrow digging chain)			
	Gasoline engines	1300 lb	590 kg
	Diesel engine	1760 lb	798 kg

TRENCH SIZES:			
DEPTH		WIDTH	
U.S.	METRIC	U.S.	METRIC
24 inch	610 mm	16 ** inch	405 mm
24 inch	610 mm	14 ** inch	355 mm
30 inch	760 mm	12 * inch	305 mm
36 inch	915 mm	10 * inch	255 mm
48 inch	1220 mm	8 inch	205 mm
48 inch	1220 mm	6 inch	150 mm
48 inch	1220 mm	4 inch	100 mm
48 inch	1220 mm	3.25 inch	85 mm
* With 12" pivot option			

** With 16" pivot option

POWER OPTIONS:		U.S.	METRIC
Engine (Honda GX610)			
	Fuel — Gasoline		
	Cooling medium — Air		
	Number of cylinders — 2		
	Displacement	37.5 in ³	614 cm ³
	Bore	3.03 in	77 mm
	Stroke	2.60 in	66 mm
	Manufacturers net power rating (per SAE J1349)	18 hp	13.4 kW
	Rated speed	3600 rpm*	3600 rpm*
	Maximum torque @ 2500 rpm	31.8 ft•lb	43.1 N•m
	Max. tilt angle** All directions	20°	20°
Engine (Kubota D722-E)			
	Fuel — Diesel		
	Cooling medium — Water		
	Number of cylinders — 3		
	Displacement	43.88 in ³	719 cm ³
	Bore	2.64 in	67 mm
	Stroke	2.68 in	68 mm
	Engine manufacturers gross power rating @ 3600 rpm	18.8 hp	14.0 kW
	Maximum governed speed as installed (no load)*	3200 rpm*	3200 rpm*
	Flywheel power @ 3000 rpm (full load)	17.6 hp	13.1 kW
	Fuel consumption @ 3000 rpm	1.0 gph	3.8 L/h
	Max. tilt angle** All directions	20°	20°
*Product support may be void if engine is run above "Maximum governed speed as installed (no load)."			

**Exceeding this operating angle will cause engine damage. This DOES NOT IMPLY machine is stable to maximum angle of engine operation.

POWER TRAIN:

Ground Drive Transmission	(Drive and Dig) Infinitely variable from zero to maximum, enclosed gear box to axle, speed and direction controlled with single lever
Clutch	Mechanical, hand operated, spring loaded with tension roller for belt drive
Belt	2 strand 3V "Power Band"
Tires - drive	23 x 8.50 - 12
	23 x 10.50 - 12 (option)
Tire - trail	16 x 6.50 - 8
Trencher Drive	Mechanical - Belt drive to enclosed reduction drive, headshaft
Belt	3 strand "Power Band"
Digging chain	33,000 lb (15000 kg) test
Chain drive sprocket	Forged and tempered
Digging tools	Bolt-on cup teeth with hard surfaced edge of tungsten carbide
Spoil Handling Drive	Mechanical, attached to and rotates with headshaft

HYDRAULIC SYSTEM:

		U.S.	METRIC
Drive pump capacity @ 3200 rpm		12.6 gpm	48 L/min
Filtration	Return flow, 10 micron nominal		
Hydraulic motor, drive			
	Torque @ 2000 psi (138 bar) and 12.6 gpm (48 L/min)	1347 in•lb.	152 N•m
	Speed @ 2000 psi (138 bar) and 12.6 gpm (48 L/min)	542 rpm	542 rpm
	Displacement/rev	4.9 in ³	80 cm ³
	Pump capacity, drilling @ 3200 rpm	5 gpm	19 L/min
Hydraulic motor, drilling			

	Torque @ 2000 psi (138 bar) and 5 gpm (19 L/min)	3088 in•lb	349 N•m
	Speed @ 2000 psi (138 bar) and 5 gpm (19 L/min)	78 rpm	78 rpm
	Displacement/rev	11.9 in ³	195 cm ³
	Bidirectional		
Hydraulic cylinders:			
	Function	Boom lift, steering	
	Type	Double acting	

STEERING:	
Type — Power on drive axle, lever controlled	

FLUID CAPACITIES:		U.S.	METRIC
Fuel tank			
	Gasoline	5.4 gal	20.4 L
	Diesel	6.5 gal	24.6 L
Engine oil:			
	Honda	1.5 pt	1.4 L
	Kubota	0.84 gal	3.2 L
Hydraulic reservoir		5.5 gal	20.8 L
Hydraulic system		6.25 gal	23.7 L
Headshaft reducer oil		2.5 pt	1.2 L
Axle reducer oil		2.5 pt	1.2 L

BATTERY:

Group 26R, 12-volt, top-post; SAE Reserve Capacity 60-80 min.; SAE cold crank 450 amps.

VIBRATION LEVEL

Vibration at the operator's hand during normal operation is 3.25 m/s^2 .

NOISE LEVEL

Operator 89 dBA sound pressure per ISO 6394

Exterior 100 dBA sound power per ISO 6393

Specifications are called out according to SAE recommended procedures. Specifications are general and subject to change without notice. If exact measurements are required, equipment should be weighed and measured. Due to selected options, delivered equipment may not necessarily match that described.

WARRANTY

Ditch Witch Equipment and Parts Limited Warranty Policy

Subject to the limitations and exclusions herein, free replacement parts will be provided at any authorized Ditch Witch dealership for any Ditch Witch equipment or parts manufactured by The Charles Machine Works, Inc. (CMW) that fail due to a defect in material or workmanship within one (1) year of first commercial use (Exception: 2 years for all SK500 attachments). Free labor will be provided at any authorized Ditch Witch dealership for installation of parts under this warranty during the first year following initial commercial use of the serial-numbered Ditch Witch equipment on which it is installed.

Exclusions from Product Warranty

- Wear-related failure of parts subject to ground contact including, but not limited to, digging teeth, digging chains, sprockets, backhoe buckets, plow blades, drill pipe, drill bits, backreamers, and swivels.
- All incidental or consequential damages.
- All defects, damages, or injuries caused by misuse, abuse, improper installation, alteration, neglect, or uses other than those for which products were intended.
- All defects, damages, or injuries caused by improper training, operation, or servicing of products in a manner inconsistent with manufacturer's recommendations.
- All engines and engine accessories (these are covered by original manufacturer's warranty).
- Tires, belts, and other parts which may be subject to another manufacturer's warranty (such warranty will be available to purchaser).
- All implied warranties not expressly stated herein, including any warranty of fitness for a particular purpose and merchantability.

IF THE PRODUCTS ARE PURCHASED FOR COMMERCIAL PURPOSES AS DEFINED BY THE UNIFORM COMMERCIAL CODE, THEN THERE ARE NO WARRANTIES WHICH EXTEND BEYOND THE FACE HEREOF AND THERE ARE NO IMPLIED WARRANTIES OF ANY KIND WHICH EXTEND TO A COMMERCIAL BUYER. ALL OTHER PROVISIONS OF THIS LIMITED WARRANTY APPLY INCLUDING THE DUTIES IMPOSED.

Ditch Witch products have been tested to deliver acceptable performance in most conditions. This does not imply they will deliver acceptable performance in all conditions. Therefore, to assure suitability, products should be operated under anticipated working conditions prior to purchase.

Defects will be determined by an inspection within thirty (30) days of the date of failure of the product or part by CMW or its authorized dealer. CMW will provide the location of its inspection facilities or its nearest authorized dealer upon inquiry. CMW reserves the right to supply remanufactured replacement parts under this warranty as it deems appropriate.

Extended warranties are available upon request from your local Ditch Witch dealer or CMW.

Some states do not allow exclusion or limitation of incidental or consequential damages, so above limitation of exclusion may not apply. Further, some states do not allow exclusion of or limitation of how long an implied warranty lasts, so the above limitation may not apply. This limited warranty gives product owner specific legal rights and the product owner may also have other rights which vary from state to state.

For information regarding this limited warranty, contact CMW's Product Support department, P.O. Box 66, Perry, OK 73077-0066, or contact your local Ditch Witch dealer.

First version: 1/91; Latest version: 1/03

**A Note To
Ditch Witch
Equipment Owners:**

If your equipment was purchased through a Ditch Witch dealer, there is no need to read further.

However, if you purchased from any other source, please fill out the form on the reverse side and return it to us.

This will enable you to receive updates on this equipment as well as information on new products of interest.

Thanks for using Ditch Witch equipment.

(Please Fold Along This Line And Seal At Bottom With Tape)



**NO POSTAGE
NECESSARY
IF MAILED
IN THE
UNITED STATES**

BUSINESS REPLY MAIL
FIRST CLASS PERMIT NO 23 PERRY OKLAHOMA

POSTAGE WILL BE PAID BY

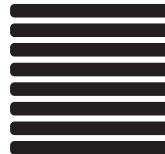

**The Charles Machine Works, Inc.
P.O. Box 66
Perry, Oklahoma 73077-9989**



Ditch Witch® Registration Card

Please Type or Print All Information

Purchaser's Company Name

Attention

Street Address or P.O. Box

City

County

State

Zip

Nation

()

Phone Number With Area Code

Model

Serial Number

Attachments/Accessories

Serial Numbers

Attachments/Accessories

Serial Numbers

Attachments/Accessories

Serial Numbers

Name of Ditch Witch Dealership

Your Signature

