

Manual No: 503010110002
REV: B
May 2023
Translated version

Maintenance Manual

AB10ERJN/AB320ERJN



CE ANSI SIA® EAC GB

SINOBOOM



WARNING

Operating, servicing and maintaining this vehicle or equipment can expose you to chemicals including engine exhaust, carbon monoxide, phthalates and lead, which are known to the State of California to cause cancer and birth defects or other reproductive harm. To minimize exposure and avoid breathing exhaust, do not idle the engine except as necessary, service your vehicle or equipment in a well-ventilated area and wear gloves or wash your hands frequently when servicing. For more information, go to: www.P65warnings.ca.gov.

For disposal, please comply with local regulations.

SINOBOOM



星邦智能

星邦

All of the above are registered trademarks of **Hunan Sinoboom Intelligent Equipment Co., Ltd.**

Contact us:

Website: www.sinoboom.com.cn / www.sinoboom.com

Sales Tel: 400-601-5828/0086-0731-87116222

Service Tel: 400-608-1289/0086-0731-87116333

E-mail: info@sinoboom.com/sales@sinoboom.com

Address: No.128, East Jinzhou Avenue, Ningxiang High-tech Industrial Park, Changsha, Hunan, China

Postal code: 410600

Copyright©Hunan Sinoboom Intelligent Equipment Co., Ltd.

Hunan Sinoboom Intelligent Equipment Co., Ltd. retains the right of final interpretation of the manual.

To Users

Thank you for choosing and using the machine of **Hunan Sinoboom Intelligent Equipment Co., Ltd.**

Use this machine only to transport tools to work locations and for performing tasks on the work platform. Only authorized personnel who have received appropriate training on MEWP can operate this machine. Before using the machine, carefully read and fully understand this manual and strictly follow its relevant instructions. Different countries, regions or governments may have different regulations for the operation of the machine, which may conflict with the manual, and in such case, the stricter operation regulations should be followed. Our company will not be liable for any adverse consequences arising from the failure to operate and use the machine in accordance with this manual or other relevant regulations.

This manual provides necessary safety precautions and maintenance instructions for users. This manual covers the basic configuration information of one or more models. Please refer to the information applicable to your machine model. Consider this manual as a part of the machine, and always keep the manual with the machine. Without the written permission of Sinoboom, do not copy, spread, sell or alter the manual.

Due to continuous improvement and upgrading of product design and different product models covered, some charts and texts in the manual may be not applicable to your machine. Our company reserves the right to revise the manual due to technical improvement, and the manual is subject to change without further notice. Please contact Sinoboom or its authorized agent for the latest manual.

Please go to www.sinoboom.com.cn to download your desired Operation Manual, Maintenance Manual and Parts Manual.

If you have any questions, contact **Hunan Sinoboom Intelligent Equipment Co., Ltd.**

Applicable Models

The manual is applicable to machines with the following models and serial numbers:

Model	Metric Trade ID	Imperial Trade ID	Serial No.
AB10ERJN	AB10ERJN	AB320ERJN	0301000108 to present

Note:

- Check the machine model and serial number on the machine nameplate, and whose position can be found in the **Diagram of Decals Positions** section of the Operation Manual.
- Product model is indicated on the nameplate for distinction of products with different main parameters.
- Product trade identification is indicated on marketing materials and machine decals for distinction of products with different main parameters, and can be classified as metric type and imperial type: the metric trade identification is applicable to the machines for countries/regions using metric system or as specially required by customers; the imperial trade identification is applicable to the machines for countries/regions using imperial system or as specially required by customers.

CONTENTS

1	Safety Warning Symbols and Signs	1		
2	Maintenance Safety Precautions	5		
2.1	General	5		
2.2	Instructions before Maintenance ..	5		
	Requirements for Maintenance Personnel	5		
	Precautions before Maintenance	5		
2.3	Maintenance Safety	6		
2.4	Considerations after Maintenance	10		
3	Technical Characteristics 11			
3.1	Machine Specifications	11		
3.2	Specifications of Major Components	13		
	Motor	13		
	Reducer	13		
	Battery	13		
	Power Unit	14		
	Motor	14		
3.3	Movement Speed	14		
3.4	Weight of Major Components	15		
3.5	Pressure Limits	16		
3.6	Oil Requirements	16		
3.7	Torque Specifications	17		
	Special Torque Requirements	17		
	Fastener Torque Specifications	18		
	Hydraulic Hose Torque	19		
	Hydraulic Fitting Torque	20		
4	Maintenance Instructions 23			
4.1	Inspection and Preventative Maintenance Schedule	23		
	Pre-delivery Inspection	23		
	Pre-operation Inspection	23		
	Frequent Inspection	23		
	Annual Machine Inspection	23		
	Preventive Maintenance	23		
	Responsible Persons and Qualifications for Performing Inspection and Maintenance	24		
	Inspection and Preventative Maintenance Schedule	24		
4.2	General Maintenance Instructions	28		
4.3	Major Modification and Repair ..	31		
5	Chassis and Turntable Assembly	33		
5.1	Chassis and Turntable System ..	33		
	Travel Speed Reduction System	33		
	Chassis Tilt Sensing System	33		
	Travel Drive System	33		
	Reverse Drive Confirmation System ..	33		
	Auxiliary Power System	33		
5.2	Tire Assembly	33		
	Check Wheel Fasteners	34		
	Replacement Requirements	34		
	Replace Tires	34		
5.3	Travel Drive Device	35		
	Check Disengaged Drive Hub Cap ..	36		
	Check Oil Level in Travel Reducer ..	36		
	Replace Gear Oil in Travel Reducer ..	36		
	Disassembly and Installation	37		
5.4	Front Wheel Bearing Housing	37		

5.5 Slewing Mechanism.....	38	Replace the Hydraulic Oil.....	67
Lubricate Slewing Bearing.....	39	7.5 Hydraulic Oil Return Filter.....	67
Inspect Slewing Bearing Bolts.....	39	7.6 Hydraulic Oil High-pressure Filter	67
Disassembly and Installation.....	41	7.7 Inspect Cylinder Drift.....	68
5.6 Counterweight.....	42	7.8 Hydraulic Symbols.....	68
5.7 Battery.....	43	7.9 Hydraulic Schematic Diagram ...	69
6 Boom and Platform		8 Electrical System.....	71
Assembly.....	45	8.1 Battery.....	71
6.1 Boom and Platform System.....	45	Inspection.....	71
Platform Control Enable System.....	45	Adding Water.....	72
Transport Position Sensing System .	45	Equalization.....	72
Load Sensing System.....	45	Storage.....	72
6.2 Platform and Jib Boom.....	46	8.2 Charging Faults and Solutions ...	73
Platform Controller.....	46	Charging Faults and Solutions	
Platform Assembly.....	46	(Lead-acid Battery).....	73
Jib Boom Assembly.....	47	Charging Faults and Solutions	
Swing Cylinder.....	47	(Lithium Battery).....	74
Upward Leveling Cylinder.....	48	8.3 Fault Codes Description.....	75
6.3 Boom.....	49	Machine Fault Codes.....	75
Drag Chain Assembly.....	49	Motor Controller Fault Codes.....	78
Downward Leveling Cylinder.....	50	Lithium Battery BMS Fault Codes ...	92
Main Boom Lift Cylinder.....	51	8.4 Basic Trouble Shooting.....	93
Main Boom Assembly.....	52	8.5 Electrical Symbols.....	96
Articulated Boom Lift Cylinder.....	53	8.6 Electrical Schematic Diagram....	98
Articulated Boom Assembly.....	54	9 Functions and Controls	101
Boom Slider.....	55	9.1 Drive Function.....	101
Telescopic Cylinder.....	57	9.2 Braking Function.....	101
7 Hydraulic System.....	59	9.3 Pothole Protection Device.....	102
7.1 Layout of Hydraulic Elements.....	59	9.4 Tilt Protection Function.....	102
7.2 Function Valves.....	60	9.5 Maximum Working Envelope	
7.3 Power Unit.....	65	Limit Function.....	103
Inspect Motor Carbon Brush.....	66	9.6 Overload Limit Function.....	103
Suction Filter Screen.....	66	10 Control System.....	105
7.4 Hydraulic oil.....	66	10.1 Display Interface.....	105
Check the Oil Level.....	66	10.2 Home Interface After Booting .	106
Check the Cleanliness of Hydraulic		10.3 State Monitor.....	107
Oil.....	67		

10.4	Fault Inquiry	108
10.5	Setting	109
	Machine Parameter Setting.....	109
	Time Setting	112
	Machine Information	113
	Language Setting.....	113
	Unit Setting	113
11	Options	115
11.1	Secondary Guarding	115
	Device Components	116
	Installation and Removal	117
	Instructions for Use	117
	Harness and Schematic Diagram...	118
11.2	Pipe Cradle	123
	Parts List.....	123
	Installation and Removal	124
	Instructions for Use	125
11.3	Panel Cradle	125
	Parts List.....	126
	Installation and Removal	127
	Instructions for Use	128
11.4	Platform Mesh	128
	Parts List.....	129
	Installation and Removal	131
	Instructions for Use	133
12	Appendix.....	135
12.1	Major Modification and Repair Record	135
12.2	Inspection and Preventative Maintenance Schedule.....	136

1 SAFETY WARNING SYMBOLS AND SIGNS

The safety warning symbols used on the machine and in the manuals have the following meanings:



Safety warning symbol. This symbol is used to alert you to potential hazards. Please observe all safety instructions that follow the symbol to avoid possible injuries.

DANGER

Indicates an imminently hazardous situation that, if not avoided, will result in death or serious injury.

WARNING

Indicates an imminently hazardous situation that, if not avoided, could result in death or serious injury.























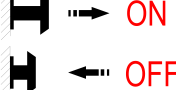

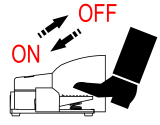
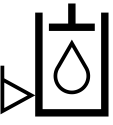
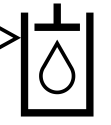

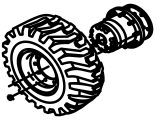
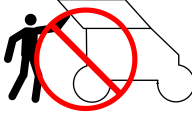
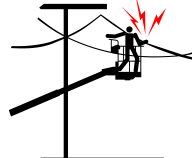
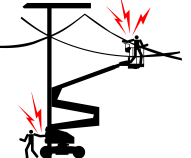
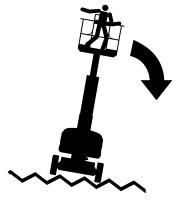
CAUTION

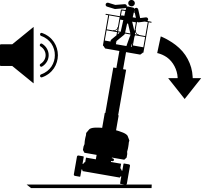
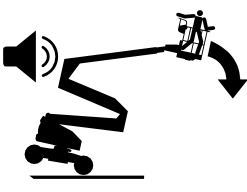

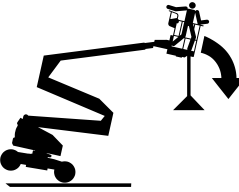

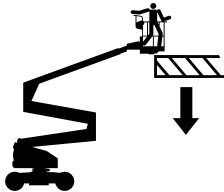







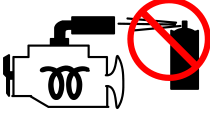

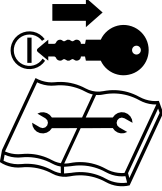

Indicates an imminently hazardous situation that, if not avoided, could result in minor or moderate injury.

NOTICE

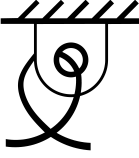
Indicates information directly or indirectly related to personal safety, machine damage, or property loss.

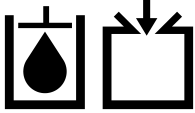
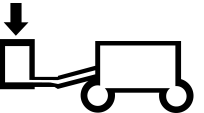
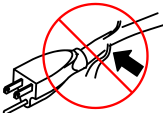
The safety signs used on the machine and in the manuals have the following meanings:

 Read maintenance manual	 Anchor point only for 1 person	 Wind speed	 Chemical burns hazard	 Wedge the wheel
 Read operation manual	 Add lubricant	 Crushing hazard- Please wear work shoes	 Danger of hot, high-pressure fluid sprays	 Wind
 Noise level	 Burns hazard	 Keep a safe distance from high temperatures	 Pull out-ON Press-OFF	 Alarm sounds
 Depress-ON Release-OFF	 Hydraulic oil level-low level	 Hydraulic oil level-high level	 Temperature	 Replace with tires of the same specification
 Only trained maintenance personnel can access the compartment	 Electrocution hazard on platform	 Electrocution hazard on the ground and platform	 Tipping hazard-Avoid uneven ground	 Tipping hazard-Avoid uneven ground
 Tipping hazard-Never use machine in strong, gusty wind	 Tipping hazard-Never use machine in strong, gusty wind	 Tipping hazard-Never push or pull objects outside platform	 Tipping hazard-Never suspend objects from platform	 Tip-over hazard-Never place ladders and scaffolding on platform
				

<p>Collision hazard-Keep extended platform away from obstacles below when lowering platform</p>	<p>Collision hazard-Keep head away from overhead obstacles when raising platform</p>	<p>Crushing hazard-Keep hands away from overhead obstacles when raising platform</p>	<p>Fall hazard-Never climb on guardrails of platform</p>	<p>Fall hazard-Never climb on boom</p>
 <p>Keep away from rotating platform</p>	 <p>Engine preheating explosion hazard</p>	 <p>Never use ether or other starting additives for machines with glow plug</p>	 <p>Fuel explosion hazard</p>	 <p>Wear protective clothing and glasses</p>
 <p>Only professional maintenance personnel can perform maintenance</p>	 <p>Side force</p>	 <p>Electrocution hazard</p>	 <p>Battery explosion hazard</p>	 <p>No fire</p>
 <p>No smoking</p>	 <p>Lifting point</p>	 <p>Lashing point</p>	 <p>Tire-to-ground load</p>	 <p>Hydraulic oil filler</p>
 <p>Platform carrying capacity</p>	 <p>Do not use damaged cords</p>	 <p>Tool or weight</p>	 <p>Fast/high speed</p>	 <p>Slow/low speed</p>
 <p>Horn</p>				

This Page Intentionally Left Blank

2 MAINTENANCE SAFETY PRECAUTIONS

2.1 GENERAL

This chapter covers safety precautions that must be taken when servicing the mobile elevating work platform. Before carrying out any repair work, the maintenance personnel must carefully read and understand all warnings and precautions, and follow the maintenance instructions in this manual to perform all necessary maintenance on the mobile elevating work platform.

WARNING

Without the written permission of Hunan Sinoboom Intelligent Equipment Co., Ltd., it is forbidden to alter or modify the machine.

2.2 INSTRUCTIONS BEFORE MAINTENANCE

Requirements for Maintenance Personnel

The maintenance personnel are responsible for maintaining the machine and ensuring its safe use and normal operation. Before inspecting and maintaining this machine, the maintenance personnel should read, understand and comply with all applicable regulations and requirements of employers, local authorities and governments related to the application of this machine, and read and fully understand this manual.

The maintenance personnel shall:

- obtain appropriate qualification or authorization
- be experienced professional technicians or engineers
- be familiar with the machine being repaired and its hazards
- receive appropriate training, including but not limited to training on the use of special equipment
- be familiar with the safety precautions and related

operating procedures for maintaining this machine

NOTICE

- *Only authorized personnel who have received appropriate training and obtained qualifications can repair this machine.*
- *People who have consumed alcohol or taken medicine, those who are overtired or depressed, and those who are physically unwell are prohibited from repairing the machine.*

Precautions before Maintenance

Before machine inspections and maintenance and during maintenance, maintenance personnel must be careful and take measures to avoid dangerous situations. Those measures include, but are not limited to, the following:

1. Choose an appropriate place for maintenance.
 - Always park the machine on level, firm ground for maintenance, and ensure that the maintenance site is clean and unobstructed.
 - If the machine uses the engine as the main power source, ensure that the maintenance site is open and well ventilated. The exhaust gases from the engine contain chemicals that may cause suffocation or poisoning, so forced ventilation measures must be taken if it is necessary to start the engine in a restricted indoor area. A hose can be connected to the exhaust pipe to discharge the exhaust gases to the outside, and the doors and windows shall be opened for air circulation.
2. Choose appropriate safety protective devices.
 - The maintenance personnel must find out various potential hazards that may arise during the inspection and maintenance work, and select appropriate safety protective devices according to the maintenance work and work place conditions, such as safety helmets, protective masks, protective gloves, goggles, protective clothing, safety belts and safety shoes.
 - Before carrying out inspection and maintenance work, check and ensure that the protective devices are not damaged and are used correctly.
 - Safety protective devices must be inspected

regularly and replaced if any damage is found.

2.3 MAINTENANCE SAFETY



3. Choose appropriate repair tools.
 - Before conducting any inspection and maintenance work, the maintenance personnel shall prepare appropriate tools as required by the work, such as wrench, screwdriver, pliers, multimeter, pressure gauge, lubrication device, jack and lifting equipment.
 - While choosing a jack or lifting equipment, confirm whether its carrying capacity can meet the requirements of use. Refer to the **Weight of Major Components** section to select the device with sufficient load capacity.
 - Service tools must be kept clean and in good condition.
4. Lock the wheels after the machine is parked to prevent the machine from rolling.
5. Do not perform inspection and maintenance work while the machine is started.
 - Before performing inspection and maintenance work, make sure the machine is turned off and remove the key. A “No Operation” warning sign can be placed next to the ground controller and platform controller, or the main power switch can be pressed to prevent unrelated personnel from inadvertently starting the machine.

 WARNING
<p>If an unrelated person inadvertently starts the machine during inspection or maintenance, it may cause machine damage or personal injury.</p>

- If inspection or maintenance work must be carried out while the machine is started, at least two people should work together. One person must stand in front of the turntable controller panel or platform controller panel so as to turn off the machine at any time if necessary, another person shall carry out inspection or maintenance work, and they shall maintain close contact with each other.
6. Before maintaining electrical components, always press the main power switch.
 7. Before carrying out inspection and maintenance work, clean the machine. Prevent dust or debris from getting into the machine parts during maintenance and affecting machine performance.

Please strictly follow the above requirements during the maintenance process. In addition, take other measures to ensure safety during the maintenance process as appropriate for the actual environment.

Unsafe Maintenance Hazard

 WARNING	
	<ul style="list-style-type: none"> • Before performing any adjustment or service operations, power off all control units and ensure that all moving parts are securely secured and free from accidental movement. • Before performing any adjustment or service operations, ensure that the boom is stowed, and do not work under the raised platform/boom. If anyone needs to work under the raised platform/boom, the platform and boom must be supported with appropriate safety supports. • When lifting or moving heavy parts of the machine, use equipment with sufficient capacity, and never place heavy objects in unstable positions after moving. • When machine parts are lifted by other equipment, ensure that there are no people under and around the equipment. • When striking the brass rod with a mallet, make sure to wear goggles. • If you need to replace parts, use the original parts designated by Sinoboom. • Do not wash the machine with water. The machine contains many electronic components such as solenoid valves and sensors, which may fail or work poorly after water ingress. If water washing is necessary, please turn off the main power switch firstly, and dry the machine thoroughly before turning on the power. • Make sure the machine is turned off before using flushing equipment (such as high-pressure water gun) to clean the machine. It is forbidden to direct the water or vapor ejected from the flushing equipment at the electrical components, otherwise short circuit or electric shock may result. • After maintenance, clean the spilled hydraulic oil thoroughly and do not spill the hydraulic oil on the ground.

 WARNING
<ul style="list-style-type: none"> • After maintenance, immediately wash any hydraulic oil on the skin. • Waste hydraulic fluids, fuels, coolants and refrigerants should be recycled or disposed as per local regulations.

High Temperature and High Pressure Hazards

WARNING

- Some parts may have high surface temperature when the machine is running or after the machine has running for some time, which may cause burns through skin contact. Do not touch any hot parts!
- It is forbidden to repair or tighten hydraulic hoses or seals while the machine is live or when the oil system is under pressure.
- Before loosening or disassembling the hydraulic parts (especially the counterbalance valve on the cylinder), the hydraulic pressure of all hydraulic lines should be released and ensure that the hydraulic oil is completely cooled down.
- Disassemble the hydraulic components slowly to prevent the hydraulic oil from splashing and injuring people.
- It is forbidden to check the hydraulic leakage point by hand. Use a piece of cardboard or stiff paper to find leaks, and wear gloves to protect your hands from hydraulic fluid sprays.
- Do not operate the machine in case of hydraulic oil or air leaks. Oil or air leaked from the hydraulic system may penetrate and burn the skin.
- It is forbidden to plug leaking hydraulic oil by hand. If there is a leak, the pressure of the hydraulic system should be released first, and the maintenance should be carried out after the hydraulic oil has cooled down.
- If you are injured by ignoring the dangers of high temperature and high pressure, seek immediate medical attention. If treatment is not carried out immediately, serious complications can result.

Welding and Polishing Operation Hazards

WARNING

- Welding, grinding and polishing operations must follow the appropriate local safety operating procedures.
- Before performing welding, grinding and polishing operations, the machine should be powered off, and ensure that the wires or cables are connected correctly.
- Do not use the machine as a ground wire during welding and grinding operations.
- Always make sure that all power tools are completely placed within the perimeter of the platform. Do not hang the wires of power tools on the guardrail of the platform or in any work area outside the platform, or hang the power tools directly with wires.





Fire and Explosion Hazards

WARNING

- Do not operate the machine, charge the battery or refuel the machine in places where potentially flammable or explosive gases may be present.
- Refueling and charging should be carried out in a well-ventilated place without flames, sparks, and other hazards that may cause fire or explosion.
- For machines powered by an engine, do not refuel the machine while the engine is running.
- Never spray ether into the engine with a glow plug (if the machine is equipped with an engine).
- Never touch the battery terminals or cable clamps with tools that can generate sparks.
- Only approved non-flammable cleaning solutions should be used on the machine.

Battery Hazard

⚠ WARNING

- 
 - Be sure to read and follow the battery manufacturer's recommendations on proper battery use and maintenance procedures.
 - Non-professionals should not repair and maintain the battery system, otherwise it may cause personal injury or damage to the battery system.
- 
 - Non-professionals should not modify parameters, detection lights, etc. during the operation of the battery system, otherwise it may cause personal injury or damage to the battery system.
- 
 - Always wear goggles, protective gloves and protective clothing, and remove all rings, watches and other accessories before servicing the battery. Contact with live circuits may result in death or serious injury.
- 
 - Before replacing the battery, be sure to select an appropriate number of personnel and appropriate lifting methods.
- 
 - It is forbidden to modify the battery system without approval to avoid serious accidents.
 - When maintaining electrical components, the battery should be disconnected.
 - Never connect tools or other metal objects between the two binding posts of the battery.
 - The battery charger can only be connected to a grounded three-wire AC power outlet. Please make sure the charger is working properly before charging. Do not connect the battery directly into a power outlet.
 - In the use of the battery, if there is any abnormal conditions such as heating, deformation, leakage, peculiar smell or smoke, the battery must be stopped from use immediately and such conditions must be reported to the relevant maintenance personnel in time.
 - Batteries contain sulfuric acid and can produce explosive

⚠ WARNING

- mixtures of hydrogen and oxygen. Keep any materials (including cigarette/smoking materials) that can cause sparks or flames away from batteries to prevent explosion.
- Never touch the battery terminals or cable clamps with tools that can generate sparks.
- Never charge the battery in direct sunlight. The battery should be charged in a well-ventilated place.

⚠ CAUTION

- 
 - Avoid battery acid spillage or contact with unprotected skin. If battery acid spills, use water mixed with bicarbonate (baking soda) to neutralize the acid. In case of contact with battery acid, rinse the acid off immediately with plenty of water and seek medical attention promptly.
- Always keep the battery upright. If the battery is placed on its side or diagonally, liquid may spill out of the battery.
- End-of-life batteries may cause danger, so please do not discard them at will. Please contact the battery recycling company if you need to scrap batteries.

NOTICE

- 
 - Please use the charger provided by the manufacturer to charge the battery.
 - The charging process must be complete, and frequent intermittent charging can damage the battery.
 - The battery is only applicable for the mated equipment supplied together at delivery, so do not use the battery for other purposes.
 - Do not reverse the positive and negative poles of the battery for use.
 - Do not short-circuit the positive and negative poles of the battery system.

NOTICE

- It is forbidden to place other objects and tools on the battery to prevent short circuit in the battery.
- It is forbidden to tap, throw or step on the battery, or hit it with sharp parts.
- Do not immerse the battery in water, acidic, alkaline or salty solutions, and protect the battery from rain.
- The battery should be fully charged immediately after each use of the machine, and then the machine power switch should be turned off.

NOTICE

Battery over-discharge (continued use of battery with level of less than 10%) or battery under-voltage caused by long-term non-charging (battery with level of less than 10% not charged for more than three days), resulting in battery capacity attenuation and failure, shall not be covered by the warranty.

5. Record inspections and maintenance as required.

NOTICE

All maintenance work should include mandatory confirmation that the machine is operating properly.

WARNING

- It is forbidden to dump waste liquids at will. Waste liquids should be discharged into appropriate containers.
- Waste hydraulic fluids, fuels, coolants and refrigerants should be recycled or disposed as per local regulations.

2.4 CONSIDERATIONS AFTER MAINTENANCE

1. Check the machine functions so that faults such as oil leakage or poor operation can be detected as early as possible.
2. After maintenance, all maintained parts must be checked for abnormal operation, oil leakage, loose bolts and other problems.
3. The safety protective device needs to be restored or reinstalled, and if necessary, be recalibrated.
4. After maintenance, clear up the tools and equipment for maintenance, remove the replaced parts and loose objects, and clean up the site.

3 TECHNICAL CHARACTERISTICS

3.1 MACHINE SPECIFICATIONS

Table 3-1 Specifications

ITEM	Metric	Imperial
Product Category		
Power type	Battery	
Outrigger type	Fixed outrigger	
DIMENSION		
Max. platform height	9.62m	32ft 7in
Max. working height	11.62m	39ft 4in
Max. horizontal reach	6.3m	20ft 8in
Max. horizontal working envelope	6.9m	22ft 8in
Max. up and over height	4.63m	15ft 2in
Overall length (stowed)	5.72m	18ft 9in
Overall length (transport)	4.11m	13ft 6in
Overall width (stowed)	1.19m	3ft 11in
Overall width (transport)	1.19m	3ft 11in
Overall height (stowed)	1.99m	6ft 6in
Overall height (transport)	2.5m	8ft 2in
Wheelbase	1.65m	5ft 5in
Ground clearance (with pothole protection device retracted)	0.09m	3.5in
Ground clearance (with pothole protection device extended)	0.03m	1.1in
Platform dimension (L×W×H)	1.15×0.76×1.1m	45.3×30×43.3in
PERFORMANCE		
Maximum load capacity of platform	230kg (unrestricted)	507lb (unrestricted)
Max. number of occupants	2 persons (unrestricted)	
Drive speed (stowed)	5km/h	3.1mph
Drive speed (raised)	0.8km/h	0.5mph
Gradeability	35%/19.3°	
Turntable rotation (angle/continuity)	355°/non-continuous	
Platform rotation angle	180°	
Max allowable tilt angle	3°	

Table 3-1 Specifications (Continued)

ITEM	Metric	Imperial
Turning radius (inside/outside)	1.7m/3.25m	5ft 7in/10ft 8in
Turntable tail-swing	0m	0m
Tire (spec/type)	0.56×0.18×0.45m (solid, non-marking)	22×7×17.75in (solid, non-marking)
Max. operating noise level	72dB	
IP rating	IP65	
Max. total vibration value of the platform	2.5m/s ²	
Max. root-mean-square value of the weighted acceleration of the entire machine	0.5m/s ²	
POWER		
Travel motor (rated power/rpm)	3kW, 1572rpm	
Drive×steer	2WD×2WS	
Hydraulic tank volume	20L	4.4gal (UK)/5.3gal (US)
Oil capacity of hydraulic tank	17L	4.4gal (UK)/3.7gal (US)
Hydraulic system pressure	21MPa	3045psi
Battery (number×voltage, capacity)	8×6V, 330Ah (lead-acid battery)	
Control voltage	12VDC	
WEIGHT		
Gross weight (unladen)	6760kg	14903lb
GROUND BEARING DATA		
Max. tire load	3580kg	7893lb
Pressure against ground	725kPa	105psi
ENVIRONMENT		
Max. allowable side force	400N	90lbf
Max. allowable wind speed	12.5m/s	28mph
Max. allowable altitude	1000m	3280ft
Allowable ambient temperature (lead-acid battery)	-10°C ~ 40°C	14°F ~ 104°F
Allowable ambient temperature (lithium battery)	-20°C ~ 40°C	-4°F ~ 104°F
Max. allowable relative humidity	90%	

Table 3-1 Specifications (Continued)

ITEM	Metric	Imperial
Storage environment	Stored at -20°C to 50°C (-4°F to 122°F) in a well-ventilated environment with 90% relative humidity (20°C [68°F]), and away from rain, sun, corrosive gas, inflammables and explosives.	

Note:

- a) The platform height plus the operator height (taken as 2m [6ft 7in]) is the working height.
- b) The maximum horizontal reach plus the arm length of the operator (taken as 0.6m [1ft 11in]) is the maximum horizontal working envelope.
- c) The ground bearing data is approximate, without considering different options, thus it is applicable only in adequately safe conditions.
- d) In different areas, hydraulic oil, engine oil, coolant, fuel and lubricant should be added in accordance with the environmental temperature.
- e) In cold weather, auxiliary devices are needed to start the machine.
- f) Rated platform load capacity refers to the maximum allowable load on the platform, including the weight of persons, materials, tools, accessories and other objects.
- g) It's recommended not to use the lead-acid battery under the ambient temperature below 0°C, otherwise the battery capacity will decay rapidly and the battery life will be affected.

3.2 SPECIFICATIONS OF MAJOR COMPONENTS

Motor

Table 3-2 Travel motor (PN.203010003057)

Model	JXQ-3-1B
Rated power	3kW
Rated voltage	32V
Rated current	76A
Rated RPM	1572rpm
Rated frequency	55Hz

Reducer

Table 3-3 Travel reducer (PN.204020003019)

Model	IFT007T2062
Maximum output torque	7000Nm (5163ft-lb)
Rated output torque	3500Nm (2581ft-lb)
Maximum input torque	112Nm (82.6ft-lb)
Maximum input RPM	4000rpm
Speed ratio	62.33

Table 3-4 Slewing reducer (PN.204020003035)

Model	WEA9-62-H-25R-W
Type	Worm gear reducer
Max. output torque	8000Nm (5906ft-lb)
Output RPM	≤1rpm (rated) ≤3rpm (Max.)
Max. tipping moment	35600Nm (26281ft-lb)
Holding moment	38700Nm (28569ft-lb)
Reduction ratio	62:1

Battery

Table 3-5 Maintenance-free storage battery (PN.203100003083)

Model	EV3053A—A
Rated voltage	6V
Rated capacity (at room temperature of 25°C)	255Ah (3hr) 330Ah (20hr)
Voltage at end of discharge by 80%	5.7V

Power Unit

Table 3-6 Power unit (PN.202010003076)

Motor	
Power	4.5kW
Voltage	DC48V
Current	120A
RPM	2500rpm
Pump	
Displacement	4.8cc/r

Table 3-7 Emergency power unit (PN.202010003077)

Motor	
Power	2.2kW
Voltage	24V
RPM	2800rpm
Pump	
Displacement	2.0cc/r

Motor

Table 3-8 Cycloid motor (PN.202020000014)

Model	255130A6312BAAAA
Displacement	130cc/r

3.3 MOVEMENT SPEED

Table 3-9

ITEM	Test results
Raise the main boom	24 ~ 32s
Lower the main boom	22 ~ 30s
Raise the articulated boom	22 ~ 30s
Lower the articulated boom	18 ~ 23s
Rotate the turntable (355°)-with boom fully retracted	60 ~ 70s
Rotate the turntable (355°)-with boom extended	90 ~ 100s
Extend the main boom	18 ~ 22s
Retract the main boom	13 ~ 17s
Rotate the platform (180°)	8 ~ 13s

Table 3-9 (Continued)

ITEM	Test results
Level the platform upward	16 ~ 21s
Level the platform downward	15 ~ 20s
Raise the jib boom	24 ~ 30s
Lower the jib boom	20 ~ 24s
Rotate the jib boom	15 ~ 19s
Max drive speed (30m [98.4ft]) -stowed	19 ~ 23s
Max drive speed (30m [98.4ft]) -operating	130 ~ 140s
Brake distance at maximum speed in high gear	≤2m (6.6ft)

- a) The movement speed depends on the start point and end point of the movement, rather than on the controls or switches.
- b) The test results of drive speed vary with tires of different specifications.
- c) All the speed tests should be conducted from the platform controller. The test results will differ if tested from the turntable controller.
- d) All the tests should be conducted with the hydraulic oil temperature at 50 ~ 60°C (122 ~ 140°F). If the hydraulic oil temperature is too low, the test results will be affected.

Test requirements:

Raise/lower the main boom : With the articulated boom fully lowered, and the telescopic boom fully retracted, raise the main boom from the lowest to the highest and lower the main boom from the highest to the lowest for two times.

Raise/lower the articulated boom : Raise the articulated boom from the lowest to the highest and lower the articulated boom from the highest to the lowest for two times.

Rotate the turntable : With the boom stowed, rotate the turntable through two full cycles.

Extend/retract the main boom : With the main boom horizontally positioned, extend the main boom from fully retracted to fully extended position, and retract the main boom from fully extended to fully retracted position for two times.

Rotate the platform : With the platform horizontal, rotate the platform from the leftmost to the rightmost, and rotate the platform from the rightmost to the leftmost for two times.

Level the platform : Level the platform upward from the lowest to the highest, and level the platform downward from the highest to the lowest for two times.

Raise/lower the jib boom : With the platform horizontal, raise the jib boom from the lowest to the highest, and lower the jib boom from the highest to the lowest for two times.

Rotate the jib boom : With the platform horizontal, rotate the jib boom from the leftmost to the rightmost, and rotate the jib boom from the rightmost to the leftmost for two times.

Drive-stowed position : With the machine in stowed position on level surface, switch to the high gear, and push the drive joystick to maximum travel distance to drive the machine forward and reverse for 30m/98.4ft respectively for two times.

Drive-operating position : With the machine in operating position on level surface, push the drive joystick to maximum travel distance to drive the machine forward and reverse for 30m/98.4ft respectively for two times.

Brake distance: As indicated by the “drive-stowed position” test, once the machine reaches the maximum drive speed, immediately release the joystick (starting timing) until the machine stops. Test twice.

3.4 WEIGHT OF MAJOR COMPONENTS

WARNING

- Never attempt to move heavy components without the assistance of mechanical equipment.**
- It is forbidden to place heavy components in an unstable position.**

Table 3-10

Component	Metric (kg)	Imperial (lb)
Chassis assembly	2067	4557
Turntable assembly	2846	6274
Boom assembly	1304	2875
Main boom	125	276
Telescopic boom	65	143
Upper articulated boom	87	192
Lower articulated boom	97	214
Jib boom assembly	132	291
Drag chain system	14	31
Platform	100	220
Slewing mechanism	58	128
Main boom telescopic cylinder	33	73
Upward leveling cylinder	19	42
Downward leveling cylinder	19	42
Main boom lift cylinder	53	117
Articulated boom lift cylinder	40	88
Jib boom cylinder	29	64
Platform swing cylinder	21	46
Jib boom swing cylinder	34	75
Power unit	21	46
Slewing reducer	52	115
Travel reducer	41	90

Table 3-10 (Continued)

Component	Metric (kg)	Imperial (lb)
Travel motor	34	75
Hybrid motor	21	46
Tire assembly	50	110

Note: The weight of certain components will vary with the options configured on the machine.

3.5 PRESSURE LIMITS

Table 3-11

Movement	Maximum pressure
Steer	14MPa (2031psi)
Rotate turntable	12MPa (1740psi)

3.6 OIL REQUIREMENTS

NOTICE
<ul style="list-style-type: none"> • Please choose appropriate oil according to the ambient temperature and local regulations, and the use of unqualified oil will damage the machine components. • Oils of different grades or viscosities should not be mixed. The oil to be added must have the same grade and viscosity as that of the oil being used by the machine. • If special oil is required by the environments or users, please contact Sinoboom.

WARNING
<ul style="list-style-type: none"> • Before filling oil, wait until the temperature of the machine drops to room temperature, otherwise it may cause splashes, burns or other personal injury. • It is strictly forbidden to use inferior oils. The use of inferior oils will bring damage to the machine, and the resulting failure will not be guaranteed by Sinoboom.

Hydraulic Oil

The hydraulic oil filled when the machine leaves the factory is generally L-HV32 or L-HM46 or other hydraulic oil required by customers. The environment temperature varies from region to region, so choose the hydraulic oil suitable for your region as suggested by the following table.

Table 3-12

Applicable environment temperature	amer	Mobil	Shell	Castrol
> 40°C (104°F)	L-HM46	DTE 10 Excel 46	S2M46	Hyspin AWH-M46
-25°C ~ 40°C (-13°F ~ 104°F)	L-HV32	DTE 10 Excel 32	TELLUS-S3VE32	Hyspin HVI-32
< -30°C (-22°F)	Special oil to be determined.			

Gear Oil

The gear oil filled in the factory usually has the viscosity grade of 80W-90, and is suitable for use in areas with ambient temperature range of -12 ~ 40°C (10.4 ~ 104°F). If the ambient temperature is beyond the applicable range, please select other appropriate gear oil.

The ambient temperature varies from region to region, so please choose the gear oil that suits your region according to the recommendations in the table below.

Table 3-13

Viscosity grade	Recommended ambient temperature
75W-90	-40 ~ 30°C (-40 ~ 86°F)
80W-90	-26 ~ 40°C (-14.8 ~ 104°F)
85W-90	-12 ~ 40°C (10.4 ~ 104°F)

3.7 TORQUE SPECIFICATIONS

Special Torque Requirements

Please refer to the table below for special torque requirements:

Table 3-14 Special torque requirements

No.	Description	Torque value
1	Front wheel fastening nut	246Nm (182ft-lb)
2	Rear wheel fastening nut	283Nm (209ft-lb)
3	Travel reducer fastening bolt	300Nm (221ft-lb)
4	Slewing bearing fastening bolt	265Nm (196ft-lb)
5	Counterweight fastening bolt	750Nm (554ft-lb)
6	Platform swing cylinder fastening bolt	70Nm (52ft-lb)
7	Platform swing cylinder fastening nut	600Nm (443ft-lb)
8	Cable fastening nut M8	9 ~ 11Nm (6.6 ~ 8.1ft-lb)
9	Cable fastening nut M10	18 ~ 23Nm (13.2 ~ 17ft-lb)

Fastener Torque Specifications

Unless special torque requirements are stated in this manual or other instructions, torque metric bolts to the values listed in the table below.

Table 3-15 Fastener torque specifications-Metric

Nominal diameter (mm)	Pitch (mm)	Class 8.8	Class 10.9	Class 12.9
5	0.8	7Nm (5ft-lb)	9Nm (7ft-lb)	10Nm (7ft-lb)
6	1	12Nm (9ft-lb)	15Nm (11ft-lb)	18Nm (13ft-lb)
8	1.25	30Nm (22ft-lb)	35Nm (26ft-lb)	42Nm (31ft-lb)
	1	30Nm (22ft-lb)	37Nm (27ft-lb)	45Nm (33ft-lb)
10	1.5	55Nm (41ft-lb)	75Nm (55ft-lb)	85Nm (63ft-lb)
	1.25	56Nm (41ft-lb)	77Nm (57ft-lb)	87Nm (64ft-lb)
	1	60Nm (44ft-lb)	80Nm (59ft-lb)	92Nm (68ft-lb)
12	1.75	95Nm (70ft-lb)	125Nm (92ft-lb)	150Nm (111ft-lb)
	1.5	100Nm (74ft-lb)	130Nm (96ft-lb)	155Nm (114ft-lb)
	1.25	105Nm (77ft-lb)	135Nm (100ft-lb)	160Nm (118ft-lb)
14	2	150Nm (110ft-lb)	200Nm (148ft-lb)	230Nm (170ft-lb)
	1.5	165Nm (122ft-lb)	210Nm (155ft-lb)	250Nm (184ft-lb)
16	2	230Nm (170ft-lb)	300Nm (221ft-lb)	360Nm (266ft-lb)
	1.5	250Nm (184ft-lb)	320Nm (236ft-lb)	380Nm (280ft-lb)
18	2.5	320Nm (236ft-lb)	420Nm (310ft-lb)	500Nm (369ft-lb)
	1.5	360Nm (266ft-lb)	470Nm (345ft-lb)	550Nm (406ft-lb)
20	2.5	450Nm (332ft-lb)	600Nm (443ft-lb)	700Nm (516ft-lb)
	1.5	500Nm (369ft-lb)	650Nm (479ft-lb)	770Nm (568ft-lb)
22	2.5	600Nm (443ft-lb)	800Nm (590ft-lb)	980Nm (723ft-lb)
	2	650Nm (479ft-lb)	850Nm (627ft-lb)	1050Nm (774ft-lb)
24	3	750Nm (553ft-lb)	1050Nm (774ft-lb)	1250Nm (923ft-lb)
	2	800Nm (590ft-lb)	1100Nm (811ft-lb)	1300Nm (959ft-lb)
27	3	1150Nm (848ft-lb)	1500Nm (1106ft-lb)	1800Nm (1327ft-lb)
30	3.5	1500Nm (1106ft-lb)	2000Nm (1475ft-lb)	2400Nm (1770ft-lb)

Unless special torque requirements are listed in this manual or other instructions, torque Unified Thread Standard bolts (label: UNC) to the values listed in the table below.

Table 3-16 Fastener torque specifications-Unified Thread Standard (UNC)

Nominal diameter (in)	Opposite nut size (s)	Class 5	Class 8
1/4-20	7/16"	10Nm (7ft-lb)	14Nm (10ft-lb)
5/16-18	1/2"	21Nm (15ft-lb)	29Nm (21ft-lb)
3/8-16	9/16"	37Nm (27ft-lb)	51Nm (38ft-lb)

Table 3-16 Fastener torque specifications-Unified Thread Standard (UNC)(Continued)

Nominal diameter (in)	Opposite nut size (s)	Class 5	Class 8
7/16-14	5/8"	60Nm (44ft-lb)	82Nm (60ft-lb)
1/2-13	3/4"	90Nm (66ft-lb)	130Nm (96ft-lb)
9/16-12	13/16"	130Nm (96ft-lb)	180Nm (133ft-lb)
5/8-11	15/16"	178Nm (131ft-lb)	250Nm (184ft-lb)
3/4-10	1-1/8"	315Nm (232ft-lb)	445Nm (328ft-lb)
7/8-9	-	509Nm (375ft-lb)	715Nm (527ft-lb)

Unless special torque requirements are listed in this manual or other instructions, torque Unified Thread Standard bolts (label: UNF) to the values listed in the table below.

Table 3-17 Fastener torque specification-Unified Thread Standard bolts (UNF)

Nominal diameter (in)	Opposite nut size (s)	Class 5	Class 8
1/4-28	7/16"	11.5Nm (8ft-lb)	16Nm (11ft-lb)
5/16-24	1/2"	23Nm (17ft-lb)	32Nm (24ft-lb)
3/8-24	9/16"	41Nm (30ft-lb)	58Nm (43ft-lb)
7/16-20	5/8"	65Nm (48ft-lb)	92Nm (68ft-lb)
1/2-20	3/4"	100Nm (74ft-lb)	145Nm (107ft-lb)
9/16-18	13/16"	145Nm (107ft-lb)	200Nm (148ft-lb)
5/8-18	15/16"	200Nm (148ft-lb)	280Nm (207ft-lb)
3/4-16	1-1/8"	350Nm (258ft-lb)	495Nm (365ft-lb)
7/8-14	-	560Nm (413ft-lb)	780Nm (575ft-lb)

Hydraulic Hose Torque

The hydraulic hose must be removed or installed as per the following torque.

Table 3-18 Hydraulic Hose Torque

Metric thread	L (light-duty)	S (heavy-duty)
M12×1.5	19±1Nm (14±1ft-lb)	
M14×1.5	26±2Nm (19±2ft-lb)	
M16×1.5	40±3Nm (30±2ft-lb)	
M18×1.5	50±4Nm (37±3ft-lb)	
M20×1.5	-	60±4Nm (44±3ft-lb)
M22×1.5	70±5Nm (52±4ft-lb)	-
M24×1.5	-	85±6Nm (63±4ft-lb)
M26×1.5	90±6Nm (66±4ft-lb)	-

Table 3-18 Hydraulic Hose Torque(Continued)

Metric thread	L (light-duty)	S (heavy-duty)
M30×2	120±8Nm (89±6ft-lb)	140±10Nm (103±7ft-lb)
M36×2	150±12Nm (111±9ft-lb)	180±12Nm (133±9ft-lb)
M42×2	-	260±16Nm (192±12ft-lb)
M45×2	240±15Nm (177±11ft-lb)	-
M52×2	250±16Nm (184±12ft-lb)	280±18Nm (207±13ft-lb)

Hydraulic Fitting Torque

The hydraulic fitting with metric thread must be removed or installed as per the following torque.

Table 3-19 Hydraulic Fitting Torque-Metric

Thread size	Installed to aluminum	Installed to steel	
	ED, O-ring + Circlip	ED, O-ring + Circlip	O-ring
L (light-duty)			
M10×1	18±1Nm (13±1ft-lb)	20±2Nm (15±2ft-lb)	18±1Nm (13±1ft-lb)
M12×1.5	30±2Nm (22±2ft-lb)	35±2Nm (26±2ft-lb)	30±2Nm (22±2ft-lb)
M14×1.5	42±3Nm (31±2ft-lb)	48±4Nm (35±3ft-lb)	35±2Nm (26±2ft-lb)
M16×1.5	55±4Nm (41±3ft-lb)	60±4Nm (44±3ft-lb)	40±3Nm (30±3ft-lb)
M18×1.5	75±5Nm (55±4ft-lb)	75±5Nm (55±4ft-lb)	45±3Nm (33±4ft-lb)
M22×1.5	90±6Nm (66±4ft-lb)	130±8Nm (96±6ft-lb)	60±4Nm (44±3ft-lb)
M27×2	120±8Nm (89±6ft-lb)	185±12Nm (136±9ft-lb)	100±7Nm (74±5ft-lb)
M30×2	140±8Nm (103±6ft-lb)	245±15Nm (181±11ft-lb)	135±8Nm (100±6ft-lb)
M33×2	180±10Nm (133±7ft-lb)	320±20Nm (236±15ft-lb)	160±10Nm (118±7ft-lb)
M42×2	240±15Nm (177±11ft-lb)	450±25Nm (332±18ft-lb)	210±13Nm (155±10ft-lb)
M48×2	280±20Nm (207±15ft-lb)	540±30Nm (398±22ft-lb)	260±15Nm (192±11ft-lb)
S (heavy-duty)			
M12×1.5	33±2Nm (24±2ft-lb)	43±3Nm (32±2ft-lb)	35±2Nm (26±2ft-lb)
M14×1.5	42±3Nm (31±2ft-lb)	50±4Nm (37±3ft-lb)	45±3Nm (33±2ft-lb)
M16×1.5	55±4Nm (41±3ft-lb)	75±5Nm (55±4ft-lb)	55±4Nm (41±3ft-lb)
M18×1.5	75±5Nm (55±4ft-lb)	95±6Nm (70±4ft-lb)	70±5Nm (52±4ft-lb)
M22×1.5	90±6Nm (66±4ft-lb)	140±8Nm (103±6ft-lb)	100±10Nm (74±7ft-lb)
M27×2	120±8Nm (89±6ft-lb)	185±12Nm (136±9ft-lb)	160±10Nm (118±7ft-lb)
M30×2	140±8Nm (103±6ft-lb)	245±15Nm (181±11ft-lb)	210±13Nm (155±10ft-lb)
M33×2	180±10Nm (133±7ft-lb)	320±20Nm (236±15ft-lb)	260±15Nm (192±11ft-lb)
M42×2	240±15Nm (177±11ft-lb)	450±25Nm (332±18ft-lb)	330±20Nm (243±15ft-lb)
M48×2	280±20Nm (207±15ft-lb)	540±30Nm (398±22ft-lb)	420±25Nm (310±18ft-lb)

The hydraulic fitting with British Standard Pipe (BSP) thread must be removed or installed as per the following torque.

Table 3-20 Hydraulic Fitting Torque-British Standard Pipe (BSP)

Thread size	Installed to aluminum	Installed to steel	
	ED, O-ring + Circlip	ED, O-ring + Circlip	O-ring
L (light-duty)			
G1/8A	20±1Nm (15±1ft-lb)	20±1Nm (15±1ft-lb)	-
G1/4A	35±2Nm (26±2ft-lb)	40±2Nm (30±2ft-lb)	-
G3/8A	50±3Nm (37±2ft-lb)	75±5Nm (55±2ft-lb)	-
G1/2A	75±5Nm (55±2ft-lb)	95±6Nm (70±4ft-lb)	-
G3/4A	120±8Nm (89±6ft-lb)	185±12Nm (136±9ft-lb)	-
G1A	180±10Nm (133±7ft-lb)	320±20Nm (236±15ft-lb)	-
G1-1/4A	240±15Nm (177±11ft-lb)	450±25Nm (332±18ft-lb)	-
G1-1/2A	280±20Nm (207±15ft-lb)	540±30Nm (398±22ft-lb)	-
S (heavy-duty)			
G1/4A	40±3Nm (30±2ft-lb)	43±3Nm (32±2ft-lb)	-
G3/8A	55±3Nm (41±2ft-lb)	85±5Nm (63±4ft-lb)	-
G1/2A	80±5Nm (59±4ft-lb)	120±8Nm (89±6ft-lb)	-
G3/4A	120±8Nm (89±6ft-lb)	185±12Nm (136±9ft-lb)	-
G1A	180±10Nm (133±7ft-lb)	320±20Nm (236±15ft-lb)	-
G1-1/4A	240±15Nm (177±11ft-lb)	450±25Nm (332±18ft-lb)	-
G1-1/2A	280±20Nm (207±15ft-lb)	540±30Nm (398±22ft-lb)	-

The hydraulic fitting with Unified Thread Standard (UNC/UNF) thread must be removed or installed as per the following torque.

Table 3-21 Hydraulic Fitting Torque-Unified Thread Standard (UNC/UNF)

Thread size	Installed to aluminum	Installed to steel
	O-ring	O-ring
L (light-duty)		
7/16-20	21±2Nm (15±2ft-lb)	21±2Nm (15±2ft-lb)
9/16-18	34±2Nm (25±2ft-lb)	35±2Nm (26±2ft-lb)
11/16-12	40±3Nm (30±2ft-lb)	50±4Nm (37±3ft-lb)
3/4-16	50±3Nm (37±2ft-lb)	65±4Nm (48±3ft-lb)
7/8-14	75±5Nm (55±4ft-lb)	110±8Nm (81±6ft-lb)
1-1/16-12	110±8Nm (81±6ft-lb)	140±10Nm (103±7ft-lb)
1-5/16-12	160±10Nm (118±7ft-lb)	210±15Nm (155±11ft-lb)
S (heavy-duty)		
7/16-20	21±2Nm (15±2ft-lb)	23±2Nm (17±2ft-lb)

Table 3-21 Hydraulic Fitting Torque-Unified Thread Standard (UNC/UNF)(Continued)

Thread size	Installed to aluminum	Installed to steel
	O-ring	O-ring
9/16-18	34±2Nm (25±2ft-lb)	40±3Nm (30±2ft-lb)
11/16-12	40±3Nm (30±2ft-lb)	65±4Nm (48±3ft-lb)
3/4-16	50±3Nm (37±2ft-lb)	80±6Nm (59±4ft-lb)
7/8-14	75±5Nm (55±4ft-lb)	125±10Nm (92±7ft-lb)
1-1/16-12	110±8Nm (81±6ft-lb)	185±15Nm (136±11ft-lb)
1-5/16-12	160±10Nm (118±7ft-lb)	280±20Nm (207±15ft-lb)

4 MAINTENANCE INSTRUCTIONS

4.1 INSPECTION AND PREVENTATIVE MAINTENANCE SCHEDULE

This section provides safety and other necessary information for machine operators. For maximum service life and safe operation of the machine, ensure that all necessary inspection and maintenance works have been completed before placing the machine into service.

It is quite important to establish and implement a comprehensive inspection and preventive maintenance schedule. This manual outlines the frequent inspection and maintenance works recommended by Hunan Sinoboom Intelligent Co., Ltd. Consult your national, regional or local regulations for aerial work platforms. The frequency of the inspection and maintenance must be increased as required by the environment, requirements and frequency of usage.

Pre-delivery Inspection

The pre-delivery inspection shall be performed by qualified Sinoboom equipment mechanics.

The pre-delivery inspection shall be performed before each sale, lease or rental delivery.

Refer to the **Inspection and Preventative Maintenance Schedule** for items requiring this inspection. Refer to the corresponding section of this manual to perform the inspection and maintenance procedures.

Pre-operation Inspection

Before each start of work, restart of work and change of user, and after each maintenance operation, the pre-operation inspection must be performed. Refer to the Pre-operation Inspection section of the Operation Manual for the detailed information. The Operation Manual must be entirely read and understood before performing the pre-operation inspection.

Frequent Inspection

The frequent inspection shall be performed by qualified Sinoboom equipment mechanics.

The frequent inspection shall be performed for each machine in service for 3 months or 150 hours (whichever comes first) or out of service for more than 3 months. The frequency of this inspection must be increased as required by the environment, requirements and frequency of usage.

The items included in the frequent inspection are the same as those in the pre-delivery inspection.

Annual Machine Inspection

An annual machine inspection must be performed once a year and no later than 13 months from the date of the prior annual machine inspection. Hunan Sinoboom Intelligent Equipment Co., Ltd. recommends this task be performed by a factory-trained service technician, a person recognized by Sinoboom as one who, by possession of a recognized degree, certificate and training, has successfully demonstrated the ability and proficiency to service, repair and maintain the subject Sinoboom product model.

Refer to the **Inspection and Preventative Maintenance Schedule** for items requiring this inspection, and refer to the corresponding section of this manual to perform inspection and maintenance procedures.

Preventive Maintenance

The preventive maintenance operation shall be performed by qualified Sinoboom equipment mechanics. The frequency of the inspection and maintenance must be increased as required by the environment, requirements and frequency of usage.

Refer to the **Inspection and Preventative Maintenance Schedule** for items requiring this inspection. Refer to the corresponding section of this manual to perform the inspection and maintenance procedures.

Responsible Persons and Qualifications for Performing Inspection and Maintenance

Table 4-1

Inspection Type	Inspection Frequency	Primary Responsible Persons	Service Qualifications
Pre-operation Inspection	Before each start of work, restart of work and change of user, and after each maintenance operation	User or operator	Properly trained user or operator
Pre-delivery Inspection	Before each sale, lease or rental delivery	Owner, dealer or user	Qualified Sinoboom mechanic
Frequent Inspection	In service for 3 months or 150 hours (whichever comes first) or out of service for more than 3 months	Owner, dealer or user	Qualified Sinoboom mechanic
Annual Machine Inspection	Once a year and no later than 13 months from the date of the prior annual machine inspection	Owner, dealer or user	Factory-trained service technician
Preventive Maintenance	At intervals specified in the <i>Inspection and Preventative Maintenance Schedule</i>	Owner, dealer or user	Qualified Sinoboom mechanic

Inspection and Preventative Maintenance Schedule

Perform inspection and preventive maintenance for the items in the table below at prescribed intervals. The intervals of inspection and maintenance are calculated based on the months elapsed since the machine has been put into service or the “cumulative working time” on the turntable controller display (whichever comes first).

The inspection cycle is based on the use of machine under normal working conditions, and the cycle should be shortened accordingly if the machine is used in harsh working conditions.

Table 4-2 Inspection and Preventative Maintenance Schedule

Items	Intervals		
	Before each delivery ¹ or quarterly ²	Semiannually ³	Annually ⁴
Chassis assembly			
Chassis	2	2	2
Tire	1, 2	1, 2	1, 2
Wheel fastener	1 ⁵⁰	1 ⁵⁰	1 ⁵⁰
Travel motor	1, 2	1, 2	1, 2
Travel reducer	1, 2, 6	1, 2, 6	1, 2, 6, 11
Steering component	1, 2	1, 2	1, 2
Outrigger, telescopic shaft (if equipped)	1, 2, 3	1, 2, 3	1, 2, 3
Bearing	1, 2, 5, 12	1, 2, 5, 12	1, 2, 5, 12

Table 4-2 Inspection and Preventative Maintenance Schedule (Continued)

Items	Intervals		
	Before each delivery ¹ or quarterly ²	Semiannually ³	Annually ⁴
Turntable assembly			
Turntable	2	2	2
Slewing bearing or slewing reducer	1 ⁵⁰ , 2, 6, 12	1 ⁵⁰ , 2, 6, 12	1 ⁵⁰ , 2, 6, 8, 12
Slewing reducer (if equipped)	1, 2, 6	1, 2, 6	1, 2, 6, 11
Central rotary joint	6	6	6
Slewing motor	1, 6	1, 6	1, 6
Turntable pin (if equipped)	1, 2, 3	1, 2, 3	1, 2, 3
Turntable cover assembly	1, 2, 3	1, 2, 3	1, 2, 3
Boom assembly			
Boom weldment	1, 2	1, 2	1, 2
Hose or wire rope bracket	1, 2	1, 2	1, 2
Pulley and slider assembly	1, 2	1, 2	1, 2
Bearing	1, 2, 5, 12	1, 2, 5, 12	1, 2, 5, 12
Cover or protective guard (if equipped)	1, 2	1, 2	1, 2
Drag chain or wire rope system (if equipped)	1, 2, 3, 5	1, 2, 3, 5	1, 2, 3, 5
Pivot pin and retaining ring	1, 2	1, 2	1, 2
Platform assembly			
Guardrail	2	2	2
Access gate	1, 2, 3	1, 2, 3	1, 2, 3
Floor	2	2	2
Swing cylinder	1, 2, 5, 6	1, 2, 5, 6	1, 2, 5, 6
Safety belt anchorage point	1, 2, 7	1, 2, 7	1, 2, 7
Hydraulic system			
Hydraulic pump	1, 2, 6	1, 2, 6	1, 2, 6
Hydraulic cylinder	1, 2, 5, 6	1, 2, 5, 6	1, 2, 5, 6
Oscillating cylinder exhausting (if equipped)	10 ^{NO.1}	10 ^{NO.1}	10 ^{NO.1}
Hydraulic valve	1, 2, 5, 6	1, 2, 5, 6	1, 2, 5, 6
Counterbalance valve locking check (if equipped)	10 ^{NO.1}	10 ^{NO.1}	10 ^{NO.1}
Hydraulic connecting pin and retaining ring	1, 2	1, 2	1, 2
Hydraulic hose, pipeline and joint	1, 2, 6	1, 2, 6	1, 2, 6

Table 4-2 Inspection and Preventative Maintenance Schedule (Continued)

Items	Intervals		
	Before each delivery ¹ or quarterly ²	Semiannually ³	Annually ⁴
Hydraulic tank, cap and vent	1, 2, 3, 5, 6	1, 2, 3, 5, 6	1, 2, 3, 5, 6
Hydraulic oil filter	1, 5, 6	1, 5, 6, 11 ⁵⁰	1, 5, 6, 11 ⁵⁰
Hydraulic oil	5, 6	5, 6	5, 6, 11
Electrical system			
Electrical wiring, connector	1, 2	1, 2	1, 2
Battery	1, 2, 6, 9, 12	1, 2, 6, 9, 12	1, 2, 6, 9, 12
Electrolyte	6	6	6
Charging function	3	3	3
Instrument, meter, switch, lamp, horn	1, 3	1, 3	1, 3
Functions and controls			
Platform controller	1, 3, 4, 7, 10	1, 3, 4, 7, 10	1, 3, 4, 7, 10
Turntable controller	1, 3, 4, 7, 10	1, 3, 4, 7, 10	1, 3, 4, 7, 10
Function control lock, protective device and brake	1, 3, 10	1, 3, 10	1, 3, 10
Foot switch	1, 3, 10	1, 3, 10	1, 3, 10
Emergency stop button (ground and platform)	1, 3, 10	1, 3, 10	1, 3, 10
Limit switch and main power switch	1, 3, 10	1, 3, 10	1, 3, 10
Pothole protection device (if equipped)	1, 3, 10	1, 3, 10	1, 3, 10
Overload limit system	1, 3, 10	1, 3, 10	1, 3, 10
Tilt alarm device	1, 3, 10	1, 3, 10	1, 3, 10
Drive brake	1, 3, 10	1, 3, 10	1, 3, 10
Rotation brake	1, 3, 10	1, 3, 10	1, 3, 10
Other inspection items			
Operation Manual in the manuals storage box	10	10	10
All decals/labels complete, clear and secure	10	10	10
Annual inspection date of the machine	/	/	10
No unapproved changes or additions	10	10	10
All safety publications included	10	10	10
General structural components and welds	2	2	2

Table 4-2 Inspection and Preventative Maintenance Schedule (Continued)

Items	Intervals		
	Before each delivery ¹ or quarterly ²	Semiannually ³	Annually ⁴
All fasteners, pins, protective guards and covers	1, 2	1, 2	1, 2
Grease and lubricating to specifications	10	10	10
Functional test of all systems	10	10	10
Paint and appearance	5	5	5
Inspection date stamped on the chassis	/	/	10
Notify Sinoboom of machine ownership	/	/	10

Note:

¹ Before each sale, lease or shipment;

² In service for 3 months or 250 hours; or out of service for more than 3 months;

³ In service for 6 months or 500 hours;

⁴ Once a year and no later than 13 months from the date of the prior annual machine inspection;

⁵⁰ The first inspection work shall be performed after the machine has been in service for 50 hours for the first time; This only happens once in the service life of the machine;

²⁵⁰ The first inspection work shall be performed after the machine has been in service for 250 hours for the first time. This only happens once in the service life of the machine.

NO.1 Before the machine is put into service for the first time, or before the first use after the oscillating cylinder or counterbalance valve is replaced.

Performance code:

1. Check for correct installation (accurate position, firmly installed, tightened according to the specified torque)
2. Visual inspection for damage (cracks, cracked welds, deformation, wear, corrosion, excessive wear, gouges, abrasions and exposed threads)
3. Check for normal function
4. Return to neutral position or "off" position normally (the self-reset switch can return to neutral position or "off" position after released)
5. Clean and free of foreign objects
6. Check for correct sealing, leaking and level
7. Labels complete, clear and secure
8. Check for appropriate tolerances
9. Fully charged
10. Validation/Execution
11. Replace the oil or filter element
12. Correctly lubricated

4.2 GENERAL MAINTENANCE INSTRUCTIONS

Safety and Operating Standards

Before adjusting and repairing the machine, the following precautions should be taken:

1. Cut off the power source to make the machine unable to start, and have the machine marked.
2. All controls should be turned off to avoid accidental actuation of the operating system.
3. If possible, lower the work platform to the lowest position; if not possible, ensure that the work platform will not fall.
4. Before loosening or removing the hydraulic components, the hydraulic oil pressure in the hydraulic lines should be released.

Some maintenance work may require the machine to be in a state other than those described in 1-4 above, and such work should be carried out in accordance with the specific safety measures listed in the Operation Manual and this manual.

During machine maintenance, personal safety should always be put first. Always take the weight of the parts into consideration and never attempt to move heavy parts without the assistance of mechanical equipment. It is forbidden to place heavy objects in an unstable position. Before lifting any machine parts, ensure the parts are sufficiently supported.

Cleaning

1. The most important point to extend the service life of the machine is to avoid dirt or impurities entering the critical parts of the machine. Protective measures have been taken for the machine to prevent such ingress. Protective plates, covers, seals, and filters are installed to keep the air, fuel and oil supply clean. However, in order to ensure that protective measures function properly, they should be maintained at the prescribed interval.
2. When air, fuel, or oil lines are disconnected, adjacent areas, openings and fittings should be cleaned. And immediately cover all openings to prevent foreign objects from entering.
3. During repair or maintenance, all components should be cleaned and inspected, and all piping and openings should be made clear. Cover all parts to keep them clean. All parts must be clean before installation. New parts should be stored in containers before use.

Components Disassembly and Installation

1. A safe and reasonable plan should be developed for the installation of machine components based on this manual and the site conditions.
2. The personnel carrying out the disassembly and installation should have appropriate ability, and should be able to use safety protection devices correctly.
3. Before installation, qualified personnel should inspect the ground, all concealed foundations and anchors, or there should be reliable documentation proving that the manufacturer's requirements are met.
4. The wind speed at the installation site should not be greater than 8.3m/s (18.6mph).
5. Before installation, check the site conditions such as power supply, foundation and track to make sure the installation requirements are met.
6. All components should be inspected prior to installation to verify they are in good condition.
7. High-strength bolts should be tightened in strict accordance with the requirements of this manual.
8. Acceptance of machine installed on site shall meet the following requirements:
 - 1) Relevant inspections and functional tests should be carried out to confirm that the machine has been installed correctly, that specific functional requirements are fulfilled and that all safety components are operating properly.
 - 2) Static and dynamic load tests should meet the relevant standards.
 - 3) Before putting the machine into service, the qualified person shall issue a handover certificate confirming the integrity of the machine. All test/inspection results should be recorded and an inspection report should be prepared (including the inspector's name, title and company and inspection date).
9. Machine disassembly should also meet the safety requirements for installation.
10. If mechanical assistance is required when disassembling the machine, reasonable lifting points, spreaders and lifting equipment should be selected as required by this manual and site conditions. Use adjustable lifting devices whenever possible. All spreaders (chains, slings, etc.) should be parallel to each other and perpendicular to the tip of the part being lifted whenever possible.
11. If a component with the assembly angle relative to the support less than 90° needs to be removed, take special care since the eye bolt or similar bracket cannot provide adequate supporting force in such case.

12. If certain component is difficult to remove, check that all nuts, bolts, cables, brackets, wiring, etc. have been removed, and that adjacent components are not blocking removal.

Components Disassembling and Reassembling

When disassembling or reassembling a component, follow the steps one by one. If the disassembly or assembly of one component has not been completed, do not proceed with another component. Always review the disassembly or assembly operation to make sure nothing is missing. No adjustments (unless recommended) may be made without prior approval.

Storage

Please follow the recommendations below to ensure the best performance of cylinders and avoid corrosion due to long-term storage (indoor/outdoor):

- The machine should be stored in stowed position with all tires adjusted to keep aligned.
- Fully raise and lower the platform and steer left and right twice a week to lubricate the cylinders.

Scrap of Structural Parts

- When certain major structural part fails to meet the requirements for safe use due to corrosion, wear and other reasons, it should be repaired or reinforced; otherwise it should be scrapped.
- When certain stressed structural part is permanently deformed and cannot be repaired, it should be scrapped.
- When certain major stressed structural part loses overall stability and cannot be repaired, it must be scrapped.
- When certain structural part or weld is cracked, the cause should be analyzed and reinforcing measures should be taken as appropriate for the force and cracks. Continued use is only allowed if the structural part and weld meet the original design requirements, or they should be scrapped.

Pressure-fit Parts

When assembling pressure-fit parts, use anti-seize or molybdenum disulfide-based compounds to lubricate the mating surface.

Bearing

1. After a bearing is removed, cover it to avoid dust and abrasives. Use non-flammable cleaning solvent

to clean bearings and allow them to dry in the shade. Compressed air can be used, but do not rotate the bearings.

2. If the races and balls (or rollers) have pits, notches or burn marks, the bearing should be scrapped.
3. If the bearing is still serviceable, apply a coat of oil and wrap it with clean paper (or wax paper). Do not unwrap reusable bearings or new bearings until they are ready for installation.
4. Before installation, lubricate new or serviceable bearings. When pressing the bearing into the retainer or bore, pressure should be applied on the outer race. If the bearing is to be mounted to a shaft, pressure should be applied to the inner race.

Gaskets

Check if the hole in the gasket is aligned with the opening in the mating part. If a handmade gasket is required, use gasket material or stock of equivalent material and thickness. Make sure to cut a hole in the correct position, as unsealed gaskets can cause serious system damage.

Bolt Use and Torque Application

NOTICE

Self-locking fasteners such as nylon inserts and thread locking nuts must not be reinstalled after removal.

1. When reinstalling locking fasteners, a new replacement should always be used. Use bolts with appropriate length. If the bolt is too long, it may be pressed against the adjacent part before tightening its head to the part to be mounted; If the bolt is too short, it will not have enough threads to bite and secure the parts. The replacement bolt must have the same or equivalent size as the original bolt.
2. In addition to the specific torque requirements given in this manual, standard torque values should be used on heat-treated bolts, studs, and steel nuts in accordance with recommended factory practice (see [Page 18, Fastener Torque Specifications](#)).

Hydraulic Pipeline and Electrical Wiring

When unplugging or removing hydraulic lines and electrical wires from the machine, the hydraulic lines and electrical wires and their sockets should be clearly marked, so that their reinstallation will be correct.

Hydraulic Hose and Fitting Tightening Procedures

The hydraulic hose and fitting must be installed as per the following requirements:

1. Before installation, check the seals on the hose and fitting, and replace the seal or even the hose assembly and fitting if the seal is found to be damaged or oil spills out of the seal; if not, clean the hose and fitting before installation.
2. If the seal is to be replaced, lubricate the replacement seal before installation.
3. For installation, align the fitting, hose and hose nut, and tighten the nut with the torque specified in [Page 19, Hydraulic Hose Torque](#) and [Page 20, Hydraulic Fitting Torque](#). Once the tightening torque of the fitting or hose exceeds the specified value, its seal cannot be reused.
4. After installation, test all machine functions and inspect the hose, fitting and related components for leaks.

Application of Insulating Silicone Grease to Electrical Connections

Insulating silicone grease should be applied to all electrical connections for the purpose of:

- Avoiding oxidization of the mechanical joints between the male pin and female pin.
- Avoiding electrical failure due to low conductivity between the pins in humid environment.

The following instructions should be observed to apply the insulating silicone grease to the electrical connections. Those instructions apply to all plugged connections outside of the power distribution box. The silicone grease is not suitable for the connectors with enclosed outer surface.

1. Prior to the machine assembling, apply silicone grease around the male pins and female pins inside the connectors to prevent oxidization. An injector may be used for the convenience of operation.

NOTICE

Oxidization exceeding a certain period will increase the resistance of the connector and eventually lead to electrical failure.

2. Silicone grease should be applied to each electrical cord that is exposed outside the connector to prevent short circuit. Besides, the joint between the male connector and female connector should also be applied with silicone grease. Other joints that may allow ingress of water into the connectors, like the area around the anti-pull buckle, should be properly sealed as well.

NOTICE

Since the electrical conductivity of cleaning solvents is superior to that of water, the conditions above are mostly likely to happen when using pressure cleaning method to clean the machine.

3. Silicone grease should be applied to each contact of the connectors for battery box and charger.

NOTICE

The setting-type sealant can be used to avoid short circuit and keep the connections tidy, but it will make the future removal of pins more difficult.

Lubrication

The relevant components should be lubricated at defined intervals using the lubricant with the quantity, type and grade as recommended in this manual. If the recommended lubricant is not available, contact local supplier to purchase the recommended or other satisfactory lubricant.

Hydraulic System

1. Contaminants are the primary hazard to the hydraulic system. Contaminants can enter the hydraulic system in various ways, such as improper use of hydraulic oil, moisture, grease, metal chips, sealing elements, sand, etc. entering the system during maintenance, or cavitation of the hydraulic pump due to insufficient system preheating or leakage of pump supply (suction) lines.
2. Oil in cloudy color indicates a high moisture or air content. This oil contributes to organic growth, leading to oxidation or corrosion. In such case, drain the waste oil in the hydraulic system, and fill with clean hydraulic oil after rinsing the hydraulic system.
3. Frequently check the filter for the presence of metal particles. Because hydraulic components are designed and manufactured to very tight tolerances, even a small amount of contaminants entering the system can cause wear or damage to hydraulic components and often lead to malfunction during machine operation. Hydraulic system filters should be inspected, cleaned or replaced as needed at required intervals.
4. Keep the hydraulic system clean. After disconnecting the hydraulic lines, seal the pipeline ports immediately to prevent contaminants from entering the hydraulic system. If signs of metal or rubber particles are found in the hydraulic system, the hydraulic oil should be drained immediately and the entire system flushed.

NOTICE

Metal particles may appear in the hydraulic oil or filter of the new machine due to wear of hydraulic components.

5. Disassemble or reassemble parts on clean work surfaces. Clean all metal parts using a non-flammable cleaning solvent. Lubricate parts as needed to facilitate assembly.
6. Hydraulic oils of different brands or types should not be mixed. Because they may contain different essential additives or may have different oil viscosity. It is recommended to use high-quality mineral oil with the viscosity that is suitable for the operating environment temperature of the machine.
7. Unless expressly stated in this manual, the filter element must be replaced at least once a year or every 1000 working hours, and the replacement interval should be shorter in harsh working conditions. If hydraulic oil needs to be changed, use hydraulic oil meeting or exceeding the type and specification requirements in this manual. If the hydraulic oil with same type as that supplied with the machine is not available, consult local supplier to help you select the appropriate hydraulic oil. Do not mix petroleum with synthetic base oil.
8. Take all precautions to keep the hydraulic oil clean. If hydraulic oil must be poured from the original vessel into another vessel, ensure that the vessel is kept clean and does not contain any contaminants. Make sure to clean the filter screen and replace the filter element when changing the hydraulic system hydraulic oil.
9. After the machine is shut down, carry out proper preventive maintenance measures, thoroughly check all hydraulic components, piping, fittings, etc., and check each system for functionality before putting the machine into service again.

Battery

Wash the battery with non-metallic brush and sodium bicarbonate aqueous solution, and then rinse with clean water. After cleaning, allow the battery to dry completely, and apply the battery terminals with anti-corrosion compound.

Pins and Composite Bearing

1. The connecting pin should be removed and inspected in case any of the following defects is found:
 - Excessively tilted joint
 - Noise originating from the joint during operation
2. The composite bearing should be replaced in any of the following conditions:

- Frayed or separated fiber on the sleeve surface
 - Cracked or damaged sleeve housing
 - Bearing moved or rotated into the housing
 - Debris embedded in the sleeve surface.
3. Replace the pivot pin after any of the following is detected (properly clean the pivot pin before inspection):
 - Wear in the bearing area
 - Flaking, peeling, scratches or abrasions on the pivot pin surface
 - Rusty pivot pin in the bearing area
 4. Reassemble the connecting pin and composite bearing
 - Blow off the dirt and debris on the housing. Remove any foreign objects on the bearing and housing.
 - Clean the bearing and pivot pin with a cleaning agent to remove all grease and oil. The composite bearing uses dry coupling which does not require lubrication.
 - During installation and operation, inspect the pivot pin to ensure that there are no burrs, nicks or abrasions that could damage the bearing.

4.3 MAJOR MODIFICATION AND REPAIR

A major modification/repair is a modification/repair made to the entire machine or its parts that affects the stability, strength or performance of the machine.

Each time the machine owner/company makes a major modification/repair to the machine, it should be recorded using the **Major Modification/Repair Record** in the attachment to this manual. Keep the record properly until the machine is taken out of service, or as required by the machine owner/company.

Major modifications/repairs to the machine must be performed by a qualified service technician. The machine must be inspected and verified after major modifications/repairs, with the inspection items including but not limited to all items in the **Inspection and Preventative Maintenance Schedule**. After all the inspection and verification results are good, the machine can be put back into service.

This Page Intentionally Left Blank

5 CHASSIS AND TURNTABLE ASSEMBLY

5.1 CHASSIS AND TURNTABLE SYSTEM

Travel Speed Reduction System

When the boom is in the operating position, the travel speed of the machine is automatically limited to the operating speed.

Chassis Tilt Sensing System

The chassis tilt sensing system measures the angle of the chassis relative to the horizontal level by means of a level sensor mounted in the left turntable cover. The chassis tilt indicator on the platform display panel indicates if the chassis inclination exceeds the maximum allowable tilt angle. When the chassis tilt sensing system detects that the chassis inclination exceeds the maximum allowable tilt angle, the chassis tilt indicator will flash, all movements will be blocked (in the operating position), the boom will be allowed to retract and lower and the turntable will be allowed to rotate slowly (in the non-operating position).

Travel Drive System

This machine adopts two-wheel drive. The drive system consists of two independently-controlled asynchronous AC motors, each connected to a corresponding travel reducer. Each motor is equipped with a speed sensor that transfers speed information to the corresponding motor controller. The operator can provide the drive speed and direction command to the control system through the joystick on the platform controller, and the system will calculate the allowable travel speed of the machine at this time according to the travel distance of the joystick and the position of the boom, see [Page 33, Travel Speed Reduction System](#) for details.

Reverse Drive Confirmation System

The reverse drive confirmation system warns the operator of the situation that may cause the machine to travel and steer in the direction opposite to the travel direction of the joystick. The reverse position indicator on the platform controller indicates such situation. When the boom is positioned between the two rear wheels, the system does not impose any restrictions on the travel of the machine. If the boom is positioned beyond any rear wheel while the machine is traveling, the reverse position indicator will flash, and the machine's driving and steering functions will be blocked. To restore the driving and steering functions, press the reverse position travel drive switch on the platform controller, then the reverse position indicator will be lit, indicating that the driving and steering direction of the machine is opposite to the travel direction of the joystick.

Auxiliary Power System

The batteries in one of the two battery boxes provide power to a 24V DC motor which drives the gear pump to provide auxiliary power for the machine. When the main power source fails, the auxiliary power system can be used to lower the operator in the platform to the ground. The auxiliary power system cannot be used as the main power source to drive the travel function, but can be used to return the machine to the stowed position in a short time.

5.2 TIRE ASSEMBLY

Check Tires and Rims

Check the tires and rims daily and replace the tire if any of the following defects is found:

- The tire is severely cracked, broken, deformed or has other abnormalities.
- The tire ply has a smooth, uniform cut with a total length of more than 75mm (3in).
- The tire ply has a crack or fissure that exceeds 25mm (1in) in either direction.
- The tire has a perforation with the diameter of over 25mm (1in).
- The tire has a large bulge.

- The wear extent of the tire's off-ground support surface exceeds 25%.

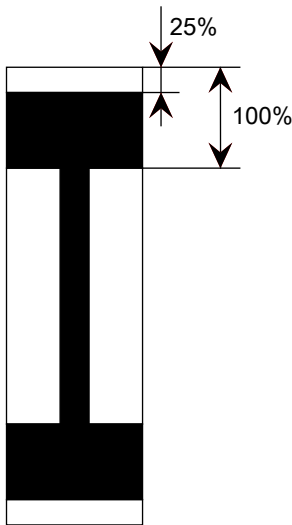

Fig 1

Check Wheel Fasteners

The wheel fasteners should be tightened before the machine is put into service for the first time and after each tire is removed. Check and tighten the wheel fasteners to the specified torque every 3 months or 250 working hours.

Replacement Requirements

WARNING

- **The tires and rims on the machine have been designed and selected according to the overall performance and load stability requirements of the machine, so their models, rim width, installation center surface, diameter, etc. must not be changed, otherwise it may result in an unsafe condition regarding stability.**
- **Use the special wheel nut that suits the rim bolt. The wheel nuts must be installed and maintained with the proper tightening torque to prevent loose rims, broken studs and tire detachment from the axle. Be sure to only use the nut that matches the cone angle of the wheel.**

Hunan Sinoboom Intelligent Equipment Co., Ltd. recommends the replacement tire be of the same size, ply rating and brand as the original tire. For the tire part number of a specific machine model, please reference its Parts Manual. If the replacement tire is not as Hunan Sinoboom Intelligent Equipment Co., Ltd. recommends, the following requirements should be met:

- With the ply rating/rated load capacity and dimension equal to or greater than the original.
- With the tire tread contact width equal to or greater than the original.
- With the wheel diameter, width and offset dimensions equal to the original.
- Approved for the application by the tire manufacturer (including intended purposes, maximum drive speed and maximum tire load, etc.).
- Due to the size difference between different tire brands, both tires on the same axle should be of the same brand.

NOTICE

Unless specifically approved by Sinoboom, do not replace foam-filled tires with pneumatic tires.

Replace Tires

WARNING

Tighten the nut to the proper torque to prevent the tire from loosening. Use a torque wrench to tighten the fastener, if you don't have a torque wrench, use a socket wrench to tighten the fastener and then immediately have a service station or dealer to tighten the fastener to the correct torque. Over-tightening will cause the bolts to break or permanently deform the bolt holes in the tires.

The correct steps to replace a tire are as follows:

1. Make sure the machine is in stowed position.
2. Press the main power switch and disconnect all power sources (such as battery charger) connected to the machine.
3. Use a wrench to loosen but do not remove the tire retaining nut.
4. Use a jack with sufficient load capacity to lift the machine frame to the appropriate height so that the tire assembly is off the ground.
5. Remove the tire retaining nuts and bolts alternately, and then remove the tire.
6. Align the mounting hole of the new tire with the corresponding mounting hole in the frame.
7. After applying Loctite 272 threadlocking adhesive to the bolts and nuts, install the bolt and nuts sequentially.
8. Tighten all nuts by hand first to prevent loosening of the bolts and nuts. Never apply lubricant to threads or nuts.
9. Then tighten the nuts step by step in the order as

shown below. Please refer to the recommended torque in the table below for tightening.

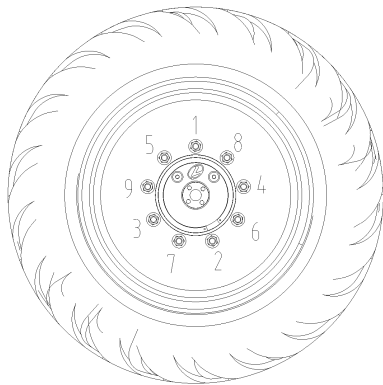

Fig 2 Diagram of wheel nuts tightening sequence

5.3 TRAVEL DRIVE DEVICE

The travel drive device is mainly composed of the travel reducer and travel motor.

Table 5-1 Table of front wheel nuts tightening torque

First step	Second step	Third step
100Nm (74ft-lb)	180Nm (133ft-lb)	246Nm (182ft-lb)

Table 5-2 Table of rear wheel nuts tightening torque

First step	Second step	Third step
100Nm (74ft-lb)	200Nm (148ft-lb)	283Nm (209ft-lb)

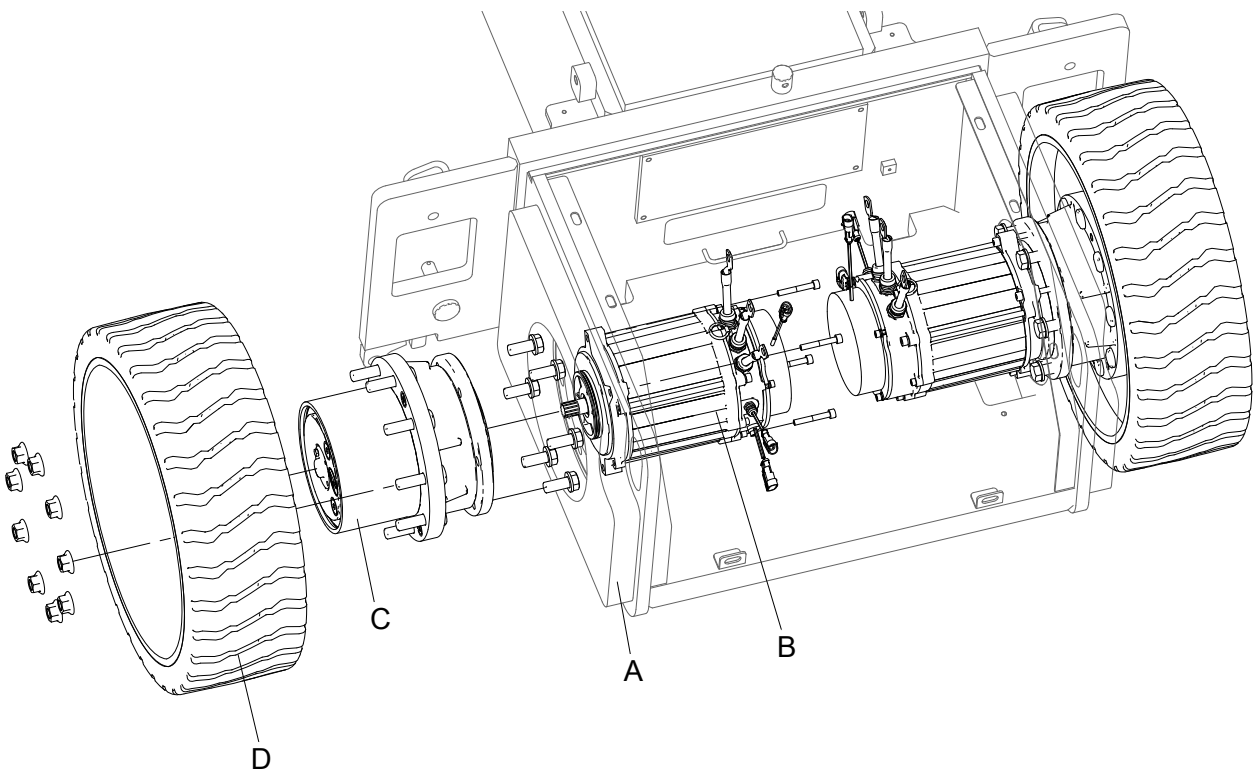

Fig 3 Diagram of travel drive device

Table 5-3 Travel drive device

No.	Description
A	Chassis weldment
B	Travel motor
C	Travel reducer
D	Tire

Check Disengaged Drive Hub Cap

The drive hub in the travel drive device can be engaged and disengaged. The two positions can be achieved by obversely mounting and reversely mounting the drive hub cap, as shown below.

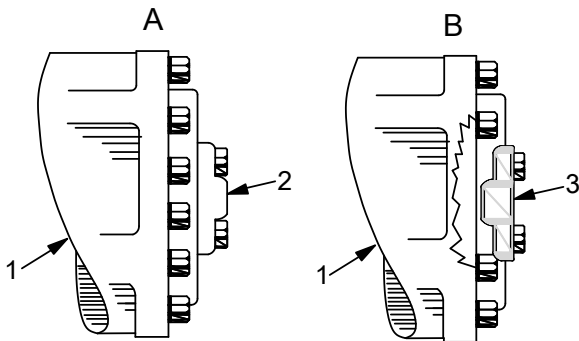

Fig 4

A Drive hub engaged

B Drive hub disengaged

1. Drive hub
2. Disengage drive hub cap (obversely mounted)
3. Disengage drive hub cap (reversely mounted)

The drive hub must be engaged for the machine to work normally. To ensure the normal and safe operation of the machine, it's recommended to visually check the drive hub cap before work.

The drive hub must be disengaged for the machine to be towed or dragged. To ensure safety, check and ensure that the drive hub is disengaged before towing or dragging, and return the drive hub to its original position once the towing or dragging is completed.

For the detailed procedures of obversely mounting and reversely mounting the drive hub cap as well as towing and dragging, refer to the **Emergency Towing** in the Operation Manual.

Check Oil Level in Travel Reducer

The travel reducer with inappropriate gear oil level will lead to reduced machine performance and even component damage. It's recommended to check the oil level in travel reducer every 3 months or after 250 working hours.

1. Drive the machine to rotate the reducer to the position with one oil port at the top (as shown below).
2. Remove the oil plug from the oil port 2, and check the oil level in the reducer, which should be even with the oil port.
3. Add oil as needed, until the oil level is even with the oil port 2.
4. Check the oil level in other travel reducers by repeating the above steps.

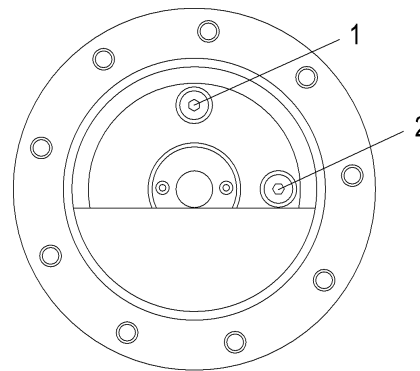

1. Oil port 1
2. Oil port 2

Fig 5 Diagram of checking oil level in travel reducer

Replace Gear Oil in Travel Reducer

Regularly replacing the gear oil in travel reducer is vital to maintaining machine performance and extending service life of the machine. It's recommended to replace the gear oil in travel reducer every year or after 1000 working hours.

Replace the gear oil in travel reducer by draining waste oil and filling with clean oil as follows:

Drain waste oil:

1. Drive the machine to rotate the reducer to the position with one oil port at the bottom.
2. Place a suitable vessel under the oil port at the bottom of reducer.
3. Remove the oil plug from the oil port at the bottom to drain the gear oil in the travel reducer to the vessel.
4. Reinstall the oil plug.

Fill with clean oil:

1. Drive the machine to rotate the reducer to the position with one oil port at the top (as shown above).
2. Remove the oil plug from the oil port 1 and oil port 2.
3. Add new gear oil to the oil port #1 until the oil level is even with the oil port #2 (refer to **Oil Requirements** for viscosity grade).
4. Reinstall the oil plug.
5. Clean up the gear oil spills during the process.

Disassembly and Installation

Disassembly

1. Make sure the machine is in stowed position.
2. Press the main power switch and disconnect all power sources (such as battery charger) connected to the machine.
3. Place a jack of sufficient capacity under the chassis side to be removed.
4. Remove the tires and place them in an appropriate area using suitable lifting equipment.
5. Mark and disconnect the harness connections on the travel motor.
6. Use suitable lifting equipment to support the travel motor.
7. Remove the travel motor mounting bolts and slowly remove the travel motor from the chassis with the assistance of lifting equipment.
8. Use suitable lifting equipment to support the travel reducer.
9. Remove the mounting bolts and washers on the

travel reducer, and slowly remove the travel reducer from the chassis with the assistance of lifting equipment.

Installation

1. Use suitable lifting equipment to support the chassis.
2. Use suitable lifting equipment to lift the travel reducer to the correct installation position, fit the washer face with the mounting surface, apply Loctite 272 threadlocking adhesive to the mounting bolts of travel reducer and install them one by one.
3. Tighten the bolts with a torque wrench according to the specified torque.
4. After installation, fill appropriate amount of industrial gear oil (refer to the **Oil Requirements** for the viscosity grade).
5. After cleaning the mounting surface, mesh the motor spline shaft with the inner teeth of the reducer, and slowly rotate the motor housing to align the motor mounting groove with the mounting hole on the chassis.
6. After applying Loctite 272 threadlocking adhesive to the travel motor mounting bolts, install them one by one and pre-tighten them.
7. Tighten the bolts with a torque wrench according to the specified torque.
8. Reconnect the electrical harness.

5.4 FRONT WHEEL BEARING HOUSING

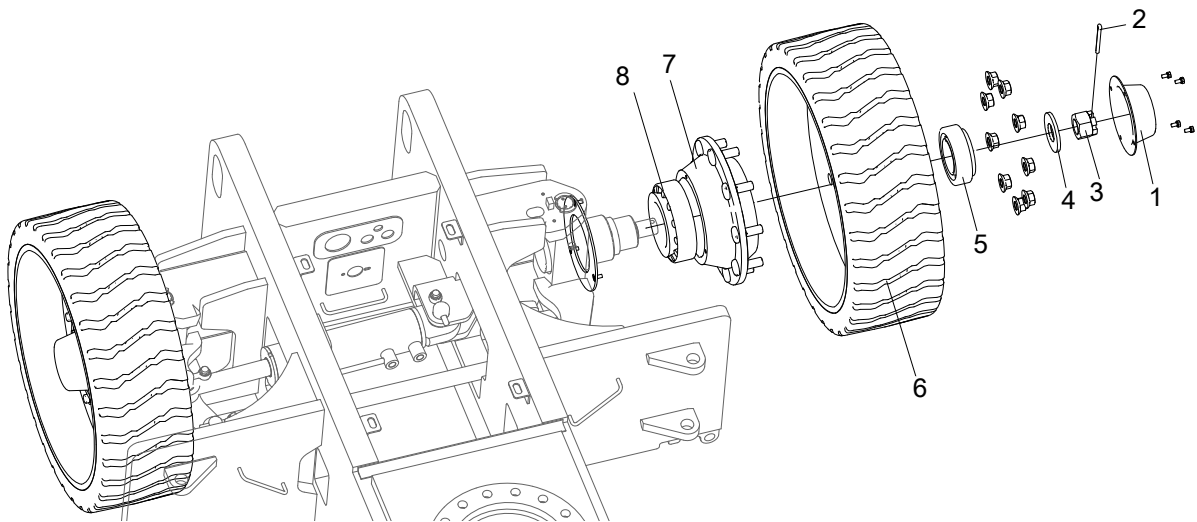

Fig 6 Diagram of installing front wheel bearing housing

Table 5-4 Travel drive device

No.	Description
1	Dust cover
2	Cotter pin
3	Slotted nut
4	Spacer
5	Bearing
6	Front tire
7	Bearing housing
8	Bearing

Precautions for disassembly and installation:

1. While installing and adjusting the wheel hub, fully tighten the slotted nut first, and then loosen it by 1/4

turn to leave proper clearance for the bearing, so that the bearing can move smoothly and without shifting.

2. Do not reuse a removed cotter pin, and replace it with a new one.

5.5 SLEWING MECHANISM

The slewing mechanism, installed on the turntable, is mainly composed of a slewing bearing (slewing reducer) and a motor, and acts as the drive device for slewing action. The inner ring (worm gear) of the slewing bearing is connected to the turntable by bolts, and the outer ring is connected to the chassis by bolts. The reducer is driven by the motor to realize the rotation of the inner ring (worm gear) of the slewing bearing, so as to rotate the turntable.

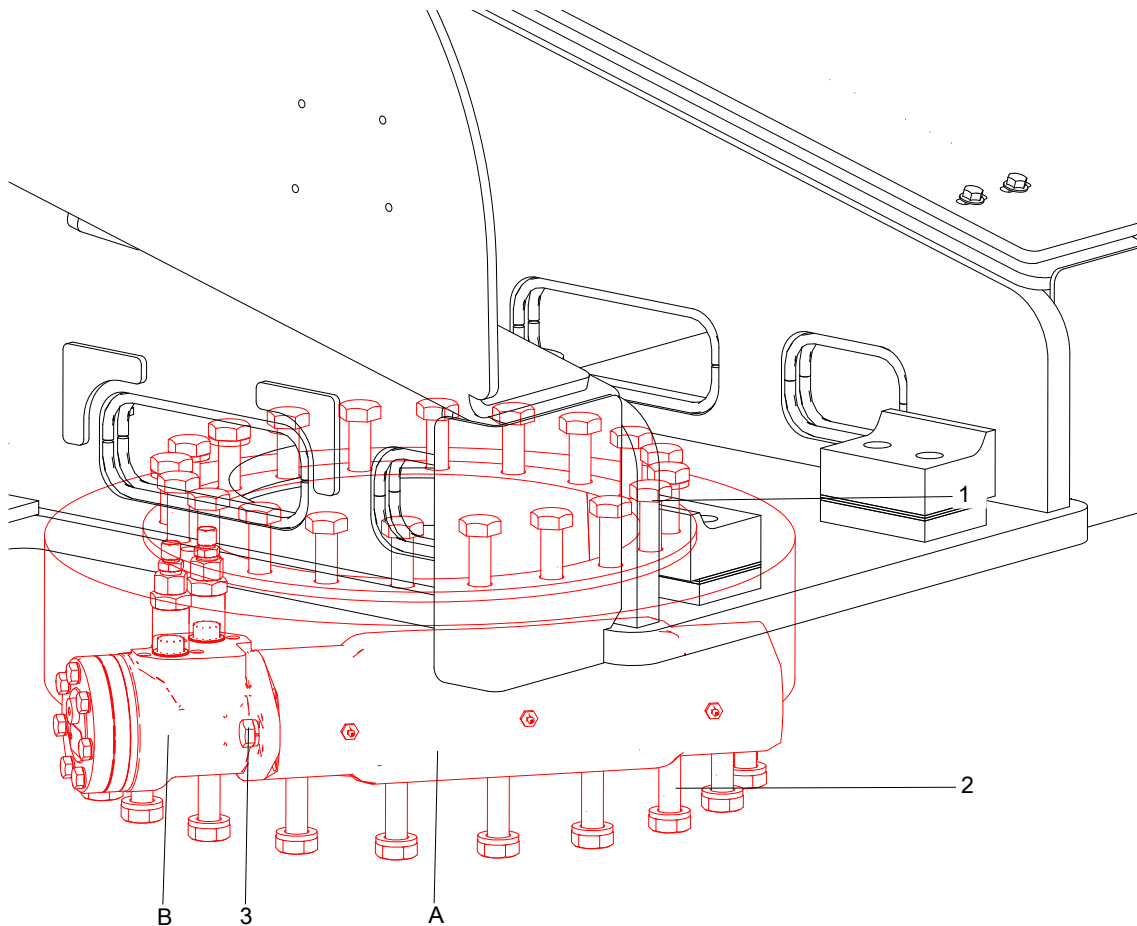

Fig 7 Diagram of slewing mechanism

Table 5-5 Slewing mechanism

No.	Description
A	Slewing bearing (slewing reducer)
B	Slewing motor

Lubricate Slewing Bearing

Regular lubrication of slewing bearing is essential to maintain machine uptime and extend service life. Failure to lubricate the slewing bearing regularly may lead to abnormal operation of the machine and accelerated component damage. It is recommended to lubricate the slewing bearing every 3 months or 250 hours of operation, and when the machine is operated in multiple shifts or exposed to harsh environments, the lubrication frequency and amount of lubricant should be increased accordingly.

1. As shown in the figure below, connect the grease nipple on the slewing bearing and the nipple at position #1 with a hose.
2. Position the oil gun nozzle on the grease nipple at position #1 and fill with ZL-3 lithium-based grease which will be transported to the turntable slewing bearing through the hose.
3. Then, rotate the turntable by 100-130mm (4-5in) each time until the whole circle is fully lubricated.
4. Position the oil gun nozzle on the grease nipple at position #2 and fill with ZL-3 lithium-based grease until the worm is fully lubricated.
5. Remove excess grease.

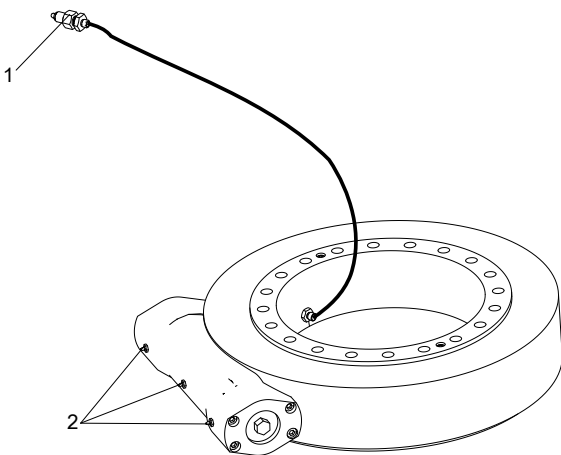

Fig 8 Diagram of lubricating slewing bearing

Inspect Slewing Bearing Bolts

It is recommended to check the slewing bearing bolts after the first 50 hours of operation, and every 3 months or 250 hours of operation thereafter.

If any bolt is found to be missing or slack, replace it with a new bolt, apply Loctite 272 threadlocking adhesive to the bolt thread and tighten the bolt with the torque specified in the **Torque Specifications** section. After replacing and tightening the slewing bearing bolt, re-inspect the bolt for tightness.

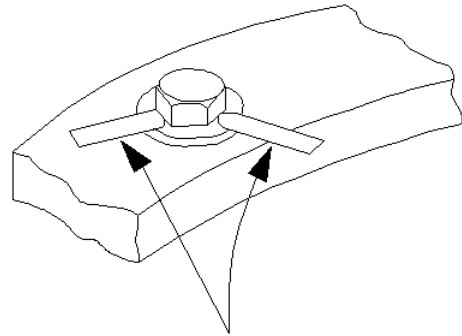

Fig 9 Instruction for inserting feeler gauge

Check the connecting bolt between the chassis and the slewing bearing

1. Adjust the machine to the position as shown in the Figure (b) below.
2. Locate the connecting bolt between the chassis and the slewing bearing.
3. As indicated by [Page 39, Instruction for inserting feeler gauge](#), insert the 0.04mm (0.0016in) feeler gauge between the bolt and washer in the quadrant opposite to the turntable counterweight.
4. Make sure that the feeler gauge will not penetrate under the bolt head to the bolt shank.
5. Rotate the turntable 90° to check the bolts in the next quadrant.
6. Rotate the turntable 90° again until all bolts have been inspected.

Check the connecting bolts between the turntable and the slewing bearing

1. Adjust the machine to the position as shown in the Figure (b) below.
2. Locate the connecting bolt between the turntable and the slewing bearing.
3. As indicated by [Page 39, Instruction for inserting feeler gauge](#), insert the 0.04mm (0.0016in) feeler gauge between the bolt and washer in the semi-circle opposite to the turntable counterweight.
4. Make sure that the feeler gauge will not penetrate under the bolt head to the bolt shank.

5. Adjust the machine to the position as shown in the Figure (a) below.
6. As indicated by [Page 39, Instruction for inserting feeler gauge](#), insert the 0.04mm (0.0016in) feeler gauge between the bolt and washer in the other semicircle (turntable counterweight).
7. Make sure that the feeler gauge will not penetrate under the bolt head to the bolt shank.

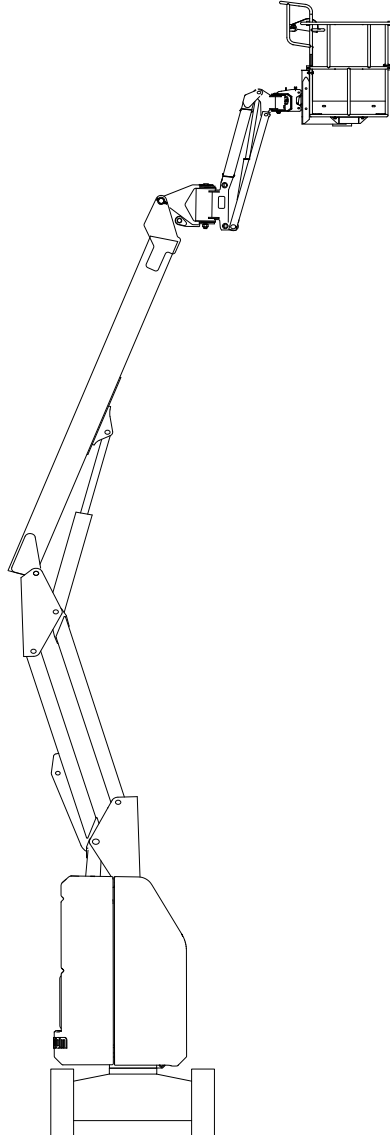

Fig 10 Checking slewing bearing connecting bolts (a)

1. Articulated boom fully elevated;
2. Main boom fully retracted and elevated.

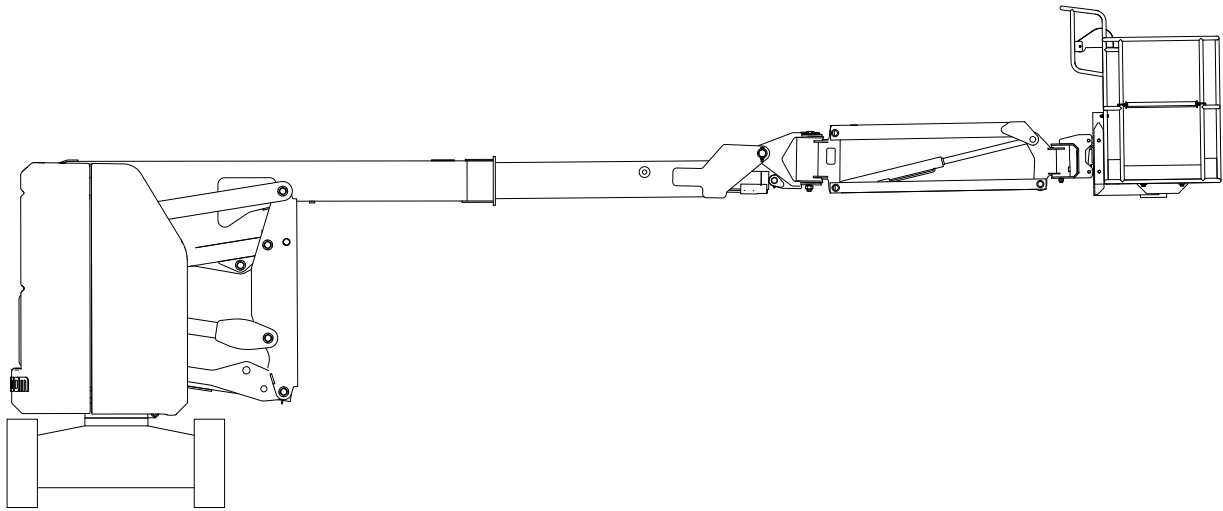

Fig 11 Checking slewing bearing connecting bolts (b)

1. Articulated boom fully retracted;
2. Main boom horizontal and fully extended.

Disassembly and Installation

Disassemble slewing motor

1. Make sure the turntable is locked (if equipped with a rotary pin, make sure the rotary pin is locked).
2. Mark and disconnect the hydraulic pipelines on the slewing motor and collect the hydraulic oil in the pipelines with a suitable vessel. Then seal the pipelines and ports.
3. Remove the slewing motor from the slewing bearing by removing the mounting bolts at position #1.

Disassemble the slewing bearing

1. Reliably support the boom with suitable lifting equipment.
2. Mark and disconnect the hydraulic pipelines on the slewing mechanism and collect the hydraulic oil in the pipelines with a suitable vessel. Then seal the pipelines and ports.
3. Support the turntable with suitable lifting equipment.
4. Use appropriate tools to draw a line on the inner ring of the slewing bearing and at the bottom of the turntable as a mark to align the slewing bearing for installation.
5. Remove the bolts and washers at position #1 that connect the turntable to the inner ring of the slewing bearing.
6. Slowly remove the entire turntable assembly from the slewing bearing with the assistance of lifting equipment and place the turntable on a bracket that

provides proper support.

NOTICE

Take extra care when removing the turntable to avoid damage to the turntable, slewing bearing and other parts on the machine.

7. Use appropriate tools to draw a line on the outer ring of slewing bearing and on the upper part of the chassis as a mark to align the bearing for mounting.
8. Remove the bolts and washers at the position #2 that connect the chassis to the outer ring of the slewing bearing.
9. Remove the slewing bearing from the chassis using suitable lifting equipment and place the slewing bearing in a clean work area that provides proper support.

NOTICE

Do not reuse removed bolts and washers, and replace with new fasteners.

Install slewing bearing

1. Clean the removed slewing bearing and take care not to damage its sealing performance.
2. Use suitable lifting equipment to lift the slewing bearing to the mounting surface of the chassis, aligning the outer ring of the slewing bearing with the marking line on the chassis.

3. Check the clearance between the slewing bearing mounting surface and the chassis mounting surface with a feeler gauge, ensuring the clearance $\leq 0.2\text{mm}$ (0.008in).
4. Using the special high-strength washers for high-strength bolts, fit the washer face with the mounting surface, and apply Loctite 272 threadlocking adhesive, and then install the bolts one by one by passing it through the chassis and the outer ring of the slewing bearing.

NOTICE

- Do not reuse removed bolts and washers, and replace with new fasteners.
- The slewing bearing is the only structural connection between the chassis and the turntable, and its replacement should meet the specification requirements. It is highly recommended that you use genuine accessories.

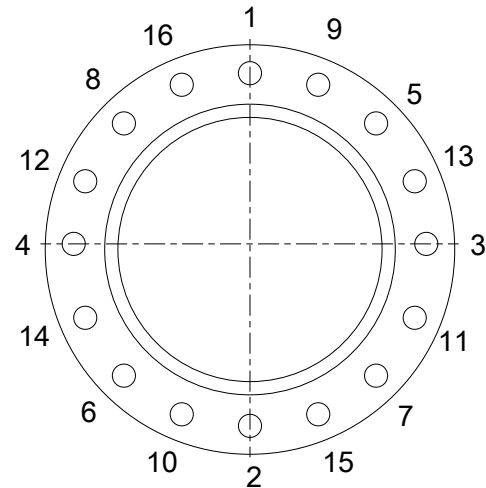

Fig 12 Tightening Sequence of Slewing Bearing Bolts

Table 5-6 Table of slewing bearing bolt tightening torques

First step	Second step	Third step
100Nm (74ft-lb)	200Nm (148ft-lb)	265Nm (196ft-lb)

5. Then tighten the bolts in the sequence shown in the following diagram and follow the steps in the table below.
6. After the bolts are tightened, mark the bolt head and its connection with an appropriate tool to facilitate later inspection of the bolts for looseness.
7. Rotate the inner ring of the slewing bearing by hand to ensure smooth movement.
8. Remove the lifting equipment from the slewing bearing.
9. Lift the turntable assembly to the top of the chassis using suitable lifting equipment, carefully lower the turntable onto the slewing bearing, and align the inner ring of the slewing bearing with the marking line on the turntable. If replacing the slewing bearing with a new one, make sure that the filling cup joint is at 90° to the left-right symmetrical line of the turntable.
10. Using the special high-strength washers for high-strength bolts, fit the washer face with the mounting surface, and apply Loctite 272 threadlocking adhesive, and then install the bolts one by one by passing it through the turntable and the inner ring of the slewing bearing.
11. Then tighten the bolts in the sequence shown in the following diagram and follow the steps in the table below.
12. After the bolts are tightened, mark the bolt head and its connection with an appropriate tool to facilitate later inspection of the bolts for looseness.
13. Remove the lifting equipment and reconnect the hydraulic hoses according to the marks before disassembly.

5.6 COUNTERWEIGHT

WARNING

Counterweights are essential to maintain the stability of the machine. Do not modify or remove counterweights without the manufacturer's written authorization. Improperly assembled counterweights may cause the machine to tip over, causing serious injury, death, or machine damage.

Disassembly

1. Adjust the machine to the stowed position and make sure the turntable is locked (if equipped with a rotary pin, make sure the rotary pin is locked).
2. Use suitable lifting equipment to provide reliable support for the boom and prevent the machine from tipping after the counterweight is removed.
3. Use suitable lifting equipment to support the counterweight.
4. Remove the bolts securing the counterweight to the turntable.
5. Slowly remove the counterweight with the aid of the lifting equipment.

Installation

1. Use suitable lifting equipment to lift the counterweight to the installation position on the turntable.
2. Align the mounting hole of the counterweight with that of the turntable structure.
3. Apply Loctite 272 threadlocking adhesive to the fastening bolt threads and counterweight threads, and install the bolts one by one.
4. Confirm that the bolts are tightened with the correct torque, refer to the **Torque Specifications** section for the tightening torque.

5.7 BATTERY

WARNING

- **Before removing the battery/battery box, the charger power supply and the working power of the whole machine must be cut off.**
- **Except professionals, other people shall not disassemble the battery case; otherwise it may cause system damage.**

1. Place the machine in a ventilated and spark-free environment.
2. Find the battery box on the side of the chassis.
3. Mark and disconnect the harness connection on the negative terminal of the battery, and then disconnect the harness connection on the positive terminal of the battery.
4. Place the forklift fork below the battery box to be removed to provide support for the battery box.
5. Remove the fasteners on the left and right sides of the battery box.
6. Slowly lower the fork to remove the battery box from the chassis.
7. Fasten the battery with the sling of appropriate lifting equipment and remove it from the battery box.

This Page Intentionally Left Blank

6 BOOM AND PLATFORM ASSEMBLY

6.1 BOOM AND PLATFORM SYSTEM

Platform Control Enable System

The platform control system uses time-dependent support circuits to limit the time availability of active or enabled controllers. The foot switch must be depressed before any movement can be performed. When the foot switch is depressed, the controller will be activated and the operator can perform any movements within 7s. The controller will remain enabled as long as the operator keeps operating any functions until 7s after the last function stops. When the controller is active, the indicator on the platform display panel will light up. After the set time, the illuminated indicator will turn off and the controller will turn off or be disabled. To continue to operate the machine, the controller must be re-enabled to start the timing system again. To activate the timing system again, follow these steps: release all control buttons, handles, and foot switch, and then depress the foot switch again.

Transport Position Sensing System

The transport position sensing system can detect the position of the boom by means of the travel switch mounted on the boom tube. When the down limit switch of the main boom or the articulated boom is not engaged, or the retraction limit switch of the main boom is not engaged, the machine is considered as in operating position; otherwise, it is considered as in non-operating position.. The position of the jib boom is not taken into account.

This system is used to control the drive speed reduction system.

Load Sensing System

The load sensing system on this machine detects the load on the platform through the load cell installed at the connection between the platform and the boom tube. The overload indicator on the platform display panel indicates if the platform load has exceeded the rated load. When the load sensing system detects that the platform load exceeds the rated load, the overload indicator will flash, and all movements of the machine will be restricted in the KG (overload limit) mode; while in other modes, the telescopic boom will be allowed to retract, the turntable can rotate slowly, and the boom can be lowered after the telescopic boom is fully retracted. After the excess load is removed, the overload indicator will go out and all machine movements will be resumed.

6.2 PLATFORM AND JIB BOOM

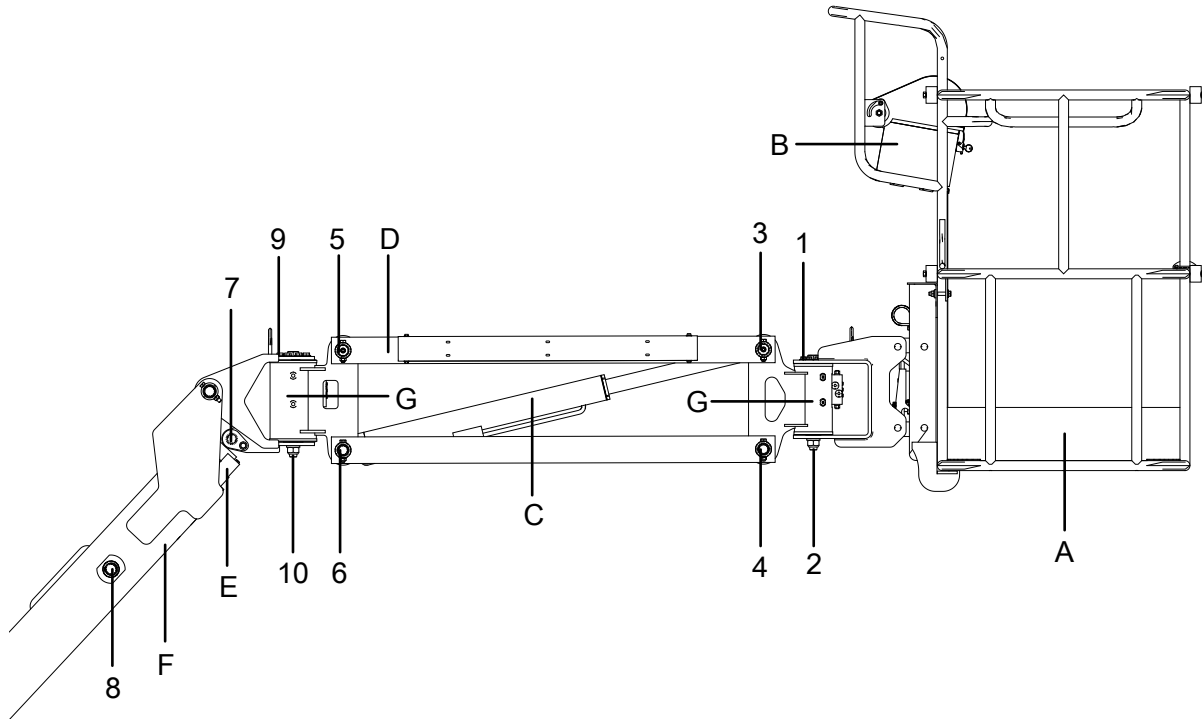

Fig 1 Diagram of Platform and Jib Boom Structure

Table 6-1 Description of platform and jib boom structure

No.	Description
A	Platform
B	Platform controller
C	Jib boom lift cylinder
D	Jib boom
E	Upward leveling cylinder
F	Boom tube
G	Swing cylinder

1. Make sure the machine is in stowed position.
2. Turn off the machine and press the emergency stop button on the platform controller and ground controller.
3. Mark and disconnect the harness connections on the platform controller.
4. Remove the fastening bolts on the bottom of the platform controller.
5. Slowly remove the platform controller.

Installation

Follow the reverse order of the disassembly procedures.

Platform Controller

Disassembly

⚠ WARNING

Before operation, be sure to disconnect the battery on the machine and the charger on the AC outlet. Contact with live conductors may result in serious injury or death.

Platform Assembly

Disassembly

1. Remove the platform controller from the platform.
2. Remove the foot switch on the platform.
3. Use suitable lifting equipment to support the work platform.
4. Remove the fastening bolt #1 at the swing cylinder and the nut at the pivot pin #2.
5. Knock out the pivot pin #2 with a brass rod and mallet.

- Slowly remove the platform assembly with the aid of the lifting equipment.

Installation

Follow the reverse order of the disassembly procedures.

Note: Make sure that the bolt at the position #1 and the nut at the position #2 of the swing cylinder have been tightened with the correct torque. Refer to the **Torque Specifications** section for the tightening torque.

Jib Boom Assembly

WARNING

- **Before loosening or disassembling the hydraulic parts (especially the counterbalance valve on the cylinder), the hydraulic pressure of all hydraulic lines should be released and ensure that the hydraulic oil is completely cooled down.**
- **Disassemble the hydraulic components slowly to prevent the hydraulic oil from splashing and injuring people.**

Remove jib boom assembly

- Adjust the main boom to horizontal, and remove the platform assembly.
- Support the jib boom and upward leveling cylinder with suitable lifting equipment.
- Mark and disconnect the hydraulic pipelines on the jib boom and collect the hydraulic oil in the pipelines with a suitable vessel. Then seal the pipelines and ports.
- Remove the fastening bolt #5 at the swing cylinder and the nut at the pivot pin #6.
- Knock out the pivot pin #6 with a brass rod and mallet.
- Slowly remove the jib boom assembly with the aid of the lifting equipment.

Remove jib boom lift cylinder

- Support the jib boom lift cylinder with suitable lifting equipment.
- Remove the bolt and nut at the pivot pin #3 and knock out the pivot pin #3 with a brass rod and mallet.
- Remove the bolt and nut at the pivot pin #6, and knock out the pivot pin #6 with a brass rod and mallet.
- With the assistance of lifting equipment, slowly

remove the jib boom lift cylinder from the jib boom.

WARNING

When disassembling the cylinder, take care to prevent damage caused by the cylinder falling and impacting, and also prevent the high-pressure oil leakage due to impacting.

Inspection

- Inspect the jib boom pivot pin for wear, scratches, deformation or other damage. Replace the pivot pin if necessary.
- Check the inner diameter of the pivot pin bearing for scratches, deformation, wear or other damage. Replace the bearing if necessary.
- Check the connecting pin of jib boom lift cylinder for wear, scratches, deformation or other damage. Before installation, ensure that the surface of the pin has received protective treatment. Replace the pin if necessary.
- Check the inner diameter of the platform swing cylinder bearing for scratches, deformation, wear or other damage. Replace the bearing if necessary.
- Check all threaded parts for elongation, thread deformation, torsion or other damage. Replace the part if needed.
- Check all structures of the jib boom assembly for deformation, cracks, weld separation or other damage. Replace the structure if necessary.

Installation

Follow the reverse order of the disassembly procedures.

Swing Cylinder

The machine has two swing cylinders for controlling the swing of platform and jib boom separately.

Check the swing cylinder fasteners

The swing cylinder fasteners are essential for the normal and safe operation of the machine. It is recommended to check the swing cylinder fasteners every 3 months or 250 hours of operation.

- Make sure the machine is in stowed position. Locate the swing cylinder at the connection of platform and boom.
- Check if the fasteners at positions #1, #2, #9 and #10 of the swing cylinder are tightened with the correct torque. Refer to the **Torque Specifications** section for the tightening torques.
- If any fastener is replaced, make sure to tighten the fastener with the torque as indicated in the **Torque Specifications** section and apply Loctite 272 threadlocking adhesive.

Disassemble platform swing cylinder

1. Remove the platform assembly.
2. Mark and disconnect the hydraulic pipelines on the platform swing cylinder and collect the hydraulic oil in the pipelines with a suitable vessel. Then seal the pipelines and ports.
3. Support the platform swing cylinder with suitable lifting equipment.
4. Remove the fastening bolts and nuts at the pivot pins #3 and #4 of the swing cylinder.
5. Knock out pivot pins #3 and #4 with a brass rod and mallet.
6. Slowly remove the platform swing cylinder with the aid of the lifting equipment.

Disassemble jib boom swing cylinder

1. Remove the jib boom assembly.
2. Mark and disconnect the hydraulic pipelines on the jib boom swing cylinder and collect the hydraulic oil in the pipelines with a suitable vessel. Then seal the pipelines and ports.
3. Support the jib boom swing cylinder with suitable lifting equipment.
4. Remove the fastening bolts and nuts at the pivot pins #5 and #6 of the swing cylinder.
5. Knock out the pivot pins #5 and #6 with a brass rod and mallet.
6. Slowly remove the jib boom swing cylinder with the aid of the lifting equipment.

Installation

Follow the reverse order of the disassembly procedures.

Upward Leveling Cylinder

WARNING

- Before loosening or disassembling the hydraulic parts (especially the counterbalance valve on the cylinder), ensure that the hydraulic pressure of all hydraulic lines is released and that the hydraulic oil is completely cooled down.
- Disassemble the hydraulic components slowly to prevent the hydraulic oil from splashing and injuring people.

Disassembly

1. Adjust the main boom and jib boom to horizontal, and extend the main boom slightly until the connecting pivot pin at the tail of the cylinder is accessible and easy to be removed.
2. Mark and disconnect the hydraulic pipelines on the upward leveling cylinder and collect the hydraulic oil in the pipelines with a suitable vessel. Then seal the pipelines and ports.
3. Use suitable lifting equipment to support the platform and jib boom assembly.
4. Remove the fastening bolt at pivot pin #7 at the piston rod end of the upward leveling cylinder. Do not move the pivot pin at this time.
5. Remove the retaining ring at shaft #8. Do not move the shaft at this time.
6. Use suitable lifting equipment to support the piston rod head of the upward leveling cylinder to protect the piston rod from damage.
7. Knock out pivot pin #7 and shaft #8 with a brass rod and mallet.
8. With the assistance of lifting equipment, slowly remove the upward leveling cylinder from the main boom.

WARNING

When disassembling the cylinder, take care to prevent damage caused by the cylinder falling and impacting, and also prevent the high-pressure oil leakage due to impacting.

Installation

Follow the reverse order of the disassembly procedures.

6.3 BOOM

Drag Chain Assembly

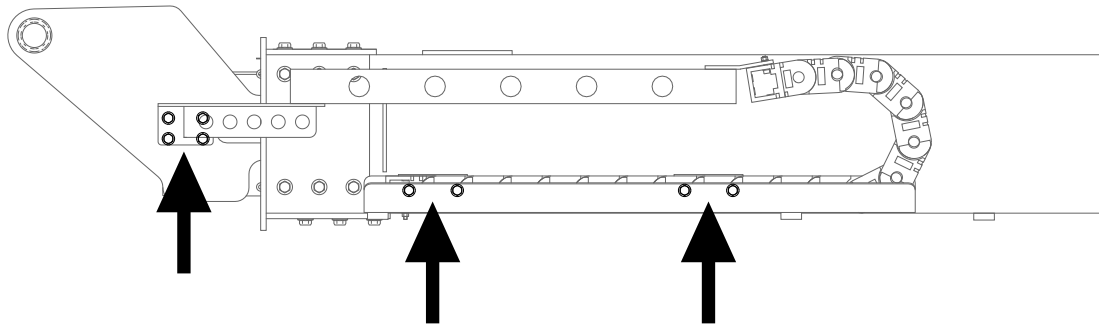

Fig 2 Fastening bolts on drag chain assembly

Disassembly

1. Make sure the machine is in the stowed position.
2. Mark and disconnect the harness connections on the drag chain assembly.
3. Mark and disconnect all hydraulic pipelines from the drag chain guide to the platform and collect the hydraulic oil in the pipelines with a suitable vessel. Then seal the pipelines and ports.
4. Remove the hydraulic pipelines and wiring harnesses from the drag chain guide.
5. Support the drag chain assembly along the length with suitable lifting equipment.
6. Remove the fastening bolts indicated by the arrows above.
7. Take appropriate preventive measures and slowly remove the drag chain assembly from the boom

tube with the aid of the lifting equipment.

8. To disassemble the drag chain separately, simply remove the fastening bolts at both ends of the drag chain.

Inspection

- Check all threaded parts for elongation, thread deformation, torsion or other damage. Replace the part if needed.
- Check all structures of the drag chain assembly for deformation, cracks, weld separation or other damage. Replace the structure if necessary.

Installation

Follow the reverse order of the disassembly procedures.

Downward Leveling Cylinder

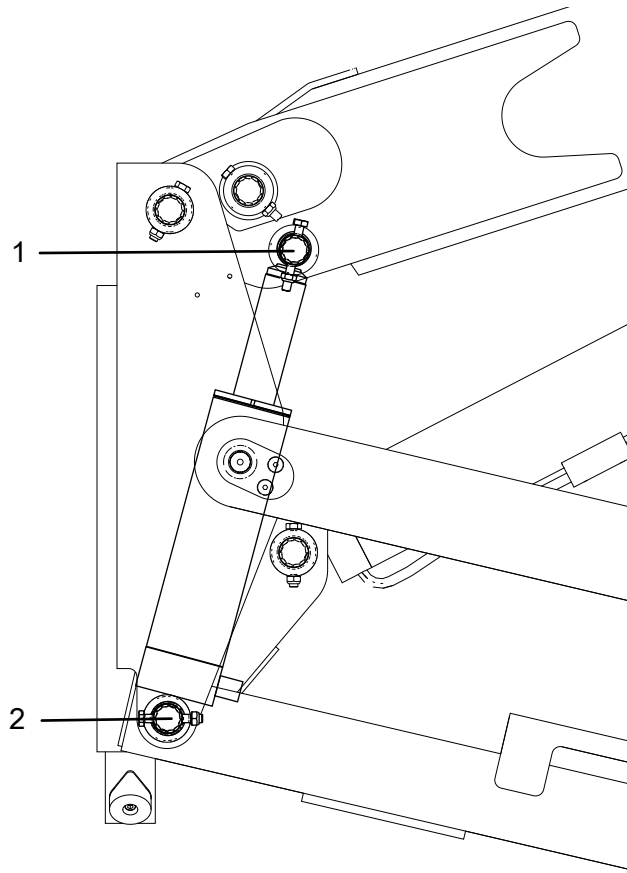

Fig 3 Downward Leveling Cylinder

⚠ WARNING

- Before loosening or disassembling the hydraulic parts (especially the counterbalance valve on the cylinder), the hydraulic pressure of all hydraulic lines should be released and ensure that the hydraulic oil is completely cooled down.
- Disassemble the hydraulic components slowly to prevent the hydraulic oil from splashing and injuring people.

Disassembly

1. Raise the boom tube slightly until the downward leveling cylinder is accessible and can be easily removed.
2. Mark and disconnect the hydraulic pipelines on the downward leveling cylinder and collect the hydraulic oil in the pipelines with a suitable vessel. Then seal the pipelines and ports.
3. Support the downward leveling cylinder with suitable lifting equipment.
4. Remove the retaining bolt at the pivot pin #1, and

knock out the pivot pin #1 with a brass rod and mallet.

5. Remove the retaining bolt at the pivot pin #2, and knock out the pivot pin #2 with a brass rod and mallet.
6. Slowly remove the downward leveling cylinder with the aid of the lifting equipment.

⚠ WARNING

When disassembling the cylinder, take care to prevent damage caused by the cylinder falling and impacting, and also prevent the high-pressure oil leakage due to impacting.

Installation

Follow the reverse order of the disassembly procedures.

Main Boom Lift Cylinder

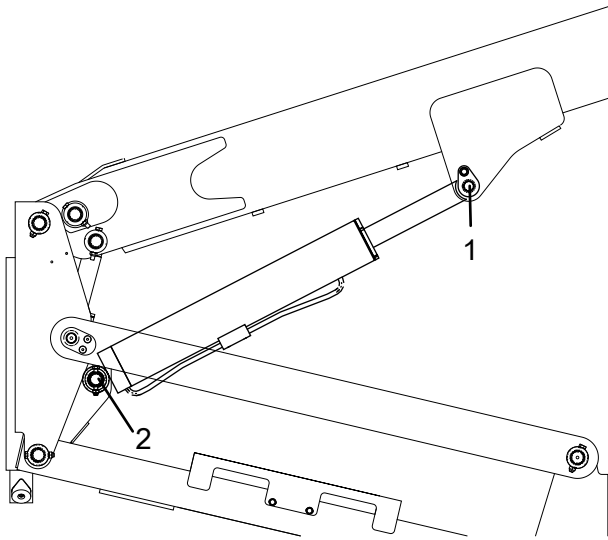

Fig 4 Main boom lift cylinder

1. Raise the boom tube slightly until the main boom lift cylinder is accessible and can be easily removed.
2. Support the main boom with suitable lifting equipment (with the lifting capacity not less than 5t/ 11023lb) to prevent it from falling during disassembly.
3. Mark and disconnect the hydraulic pipelines on the main boom lift cylinder and collect the hydraulic oil in the pipelines with a suitable vessel. Then seal the pipelines and ports.
4. Support the two ends of the main boom lift cylinder with suitable lifting equipment.
5. Remove the bolt at the pivot pin #1 connecting the lift cylinder with the boom tube, and knock out the pivot pin #1 with a brass rod and mallet.
6. Remove the screw at the pivot pin #2, and knock out the pivot pin #2 with a brass rod and mallet.
7. Slowly remove the main boom lift cylinder with the aid of the lifting equipment.
8. Slowly lower the boom tube to stowed position with the aid of the lifting equipment.

Disassembly

⚠ WARNING

- Before disassembling the lift cylinder, rotate the boom tube to be parallel to the travel direction of the chassis, and make sure the turntable is locked (if equipped with a rotary pin, make sure the rotary pin is locked).
- Before disassembling the lift cylinder, place solid and reliable rigid brackets under the counterweight for support, otherwise the machine may tip over, causing serious personal injury and machine damage.

⚠ WARNING

- Before loosening or disassembling the hydraulic parts (especially the counterbalance valve on the cylinder), ensure that the hydraulic pressure of all hydraulic lines is released and that the hydraulic oil is completely cooled down.
- Disassemble the hydraulic components slowly to prevent the hydraulic oil from splashing and injuring people.

⚠ WARNING

When disassembling the cylinder, take care to prevent damage caused by the cylinder falling and impacting, and also prevent the high-pressure oil leakage due to impacting.

Installation

Follow the reverse order of the disassembly procedures.

Main Boom Assembly

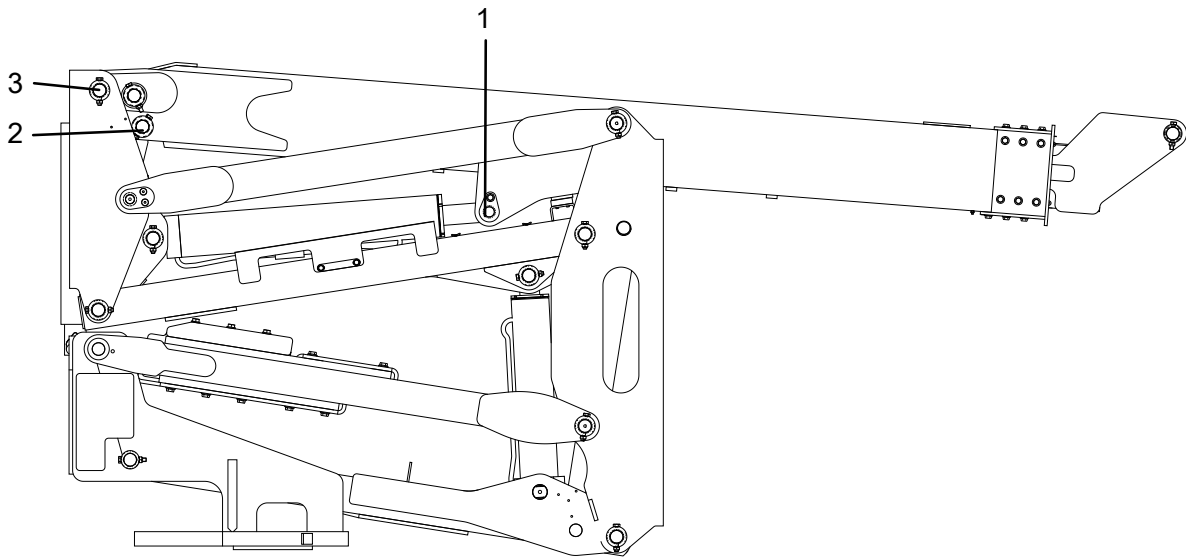

Fig 5 Main Boom Assembly

Disassembly

⚠ WARNING

- **Before disassembling the main boom assembly, rotate the boom tube to be parallel to the travel direction of the chassis, and make sure the turntable is locked (if equipped with a rotary pin, make sure the rotary pin is locked).**
- **Before disassembling the main boom assembly, place solid and reliable rigid brackets under the counterweight for support, otherwise the machine may tip over, causing serious personal injury and machine damage.**

1. Make sure to remove the platform assembly, jib boom assembly and upward leveling cylinder.
2. Raise the boom tube slightly until the main boom lift cylinder is accessible and the main boom can be easily removed.
3. Mark and disconnect all harness connections on the main boom assembly.
4. Mark and disconnect all hydraulic pipelines on the main boom assembly and collect the hydraulic oil in the pipelines with a suitable vessel. Then seal the pipelines and ports.
5. Use suitable lifting equipment (with the lifting capacity not less than 5t/11023lb) to support the main boom tail (near the platform).
6. Use suitable lifting equipment to provide reliable support for the main boom lift cylinder.

7. Remove the bolt at the pivot pin #1 connecting the main boom lift cylinder with the main boom assembly, and knock out the pivot pin #1 with a brass rod and mallet.
8. Use suitable lifting equipment (with the lifting capacity not less than 5t/11023lb) to support the main boom head (near the turntable).
9. Reliably support the upper connector and downward leveling cylinder with suitable lifting equipment.
10. Remove the bolt at the pivot pin #2 connecting the downward leveling cylinder with the main boom assembly, and knock out the pivot pin #2 with a brass rod and mallet.
11. Remove the bolt at the pivot pin #3 connecting the upper connector with the main boom assembly, and knock out the pivot pin #3 with a brass rod and mallet.
12. With the assistance of the lifting equipment, slowly remove the main boom assembly from the turntable and carefully place it on a suitable support.

Installation

Follow the reverse order of the disassembly procedures.

Articulated Boom Lift Cylinder

Disassembly

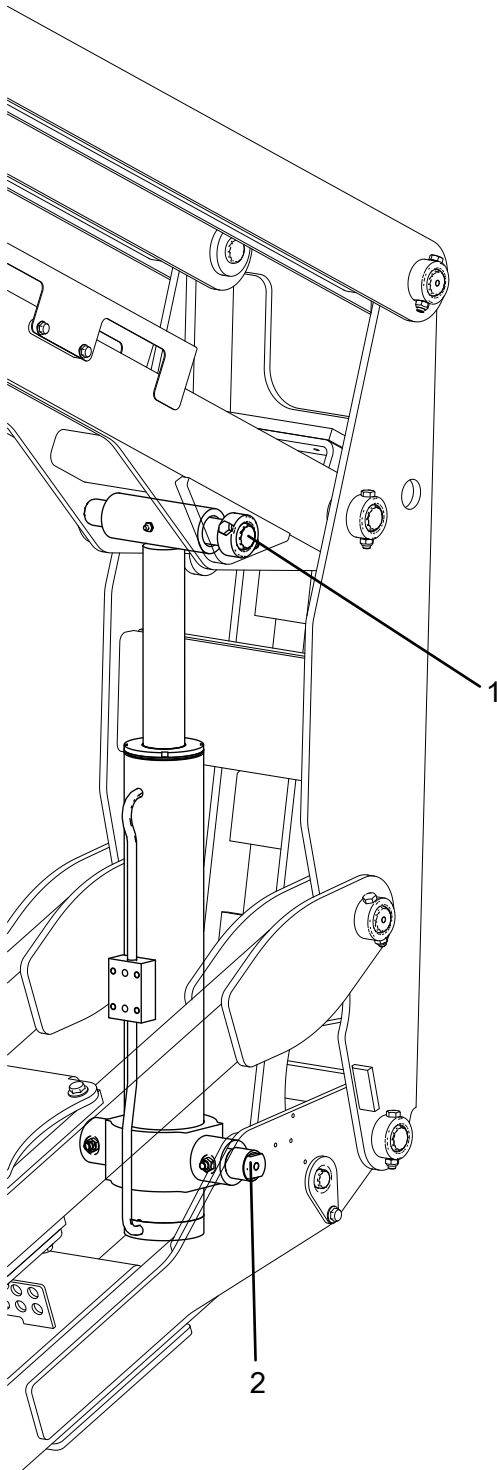

Fig 6 Articulated Boom Lift Cylinder

⚠ WARNING

- Before disassembling the lift cylinder, rotate the boom tube to be parallel to the travel direction of the chassis, and make sure the turntable is locked (if equipped with a rotary pin, make sure the rotary pin is locked).
- Before disassembling the lift cylinder, place solid and reliable rigid brackets under the counterweight for support, otherwise the machine may tip over, causing serious personal injury and machine damage.

⚠ WARNING

- Before loosening or disassembling the hydraulic parts (especially the counterbalance valve on the cylinder), the hydraulic pressure of all hydraulic lines should be released and ensure that the hydraulic oil is completely cooled down.
- Disassemble the hydraulic components slowly to prevent the hydraulic oil from splashing and injuring people.

1. Adjust the main boom to fully retracted and horizontal position.
2. Raise the articulated boom slightly until the articulated boom lift cylinder is accessible and can be easily removed.
3. Reliably support the main boom and upper connector with suitable lifting equipment to prevent the boom tube from falling during disassembly.
4. Mark and disconnect the hydraulic pipelines on the articulated boom lift cylinder and collect the hydraulic oil in the pipelines with a suitable vessel. Then seal the pipelines and ports.
5. Support the two ends of the articulated boom lift cylinder with suitable lifting equipment.
6. Remove the bolt at the pivot pin #1 connecting the articulated boom lift cylinder with the upper articulated boom, and knock out the pivot pin #1 with a brass rod and mallet.
7. Remove the bolt at the pivot pin #2 connecting the articulated boom lift cylinder with the lower articulated boom, and knock out the pivot pin #2 with a brass rod and mallet.
8. Slowly remove the articulated boom lift cylinder with the aid of the lifting equipment.
9. Slowly lower the boom tube to stowed position with

the aid of the lifting equipment.

⚠ WARNING

When disassembling the cylinder, take care to prevent damage caused by the cylinder falling and impacting, and also prevent the high-pressure oil leakage due to impacting.

Installation

Follow the reverse order of the disassembly procedures.

Articulated Boom Assembly

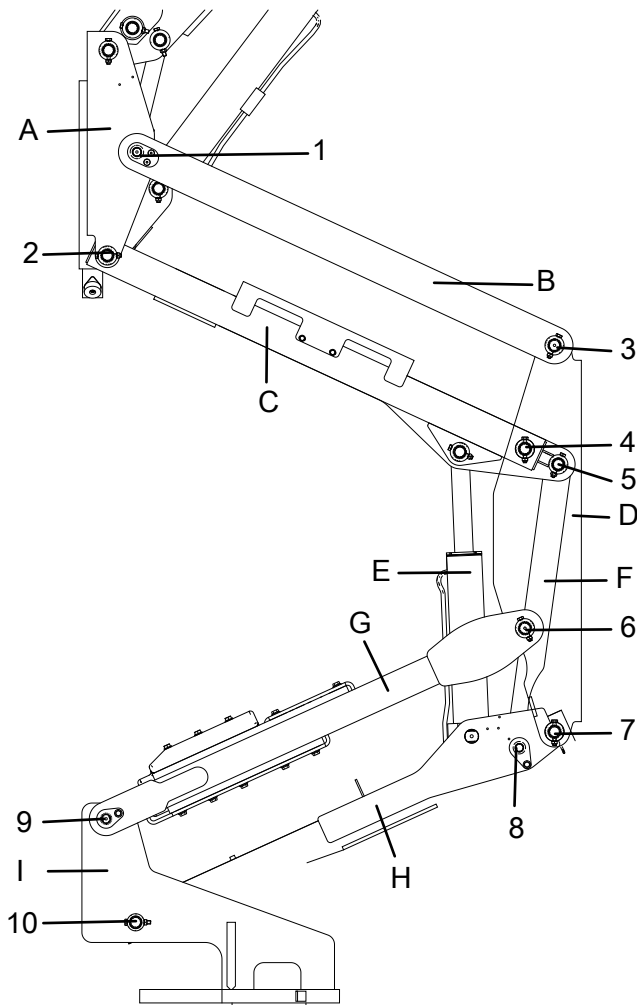

Fig 7 Articulated Boom Assembly

Table 6-2 Articulated boom assembly

No.	Description
A	Upper connector
B	Upper linkage

Table 6-2 Articulated boom assembly (Continued)

C	Upper articulated boom
D	Lower connector
E	Articulated boom lift cylinder
F	Pull rod
G	Lower linkage
H	Lower articulated boom
I	Turntable

Disassembly

⚠ WARNING

- Before disassembling the articulated boom assembly, rotate the boom tube to be parallel to the travel direction of the chassis, and make sure the turntable is locked (if equipped with a rotary pin, make sure the rotary pin is locked).
- Before disassembling the articulated boom assembly, place solid and reliable rigid brackets under the counterweight for support, or the machine may tip over, causing serious personal injury and machine damage.

1. Raise the boom tube slightly until the articulated boom assembly can be easily removed.
2. Remove the main boom assembly, main boom lift cylinder, and downward leveling cylinder.
3. Mark and disconnect all harness connections on the articulated boom assembly.
4. Mark and disconnect all hydraulic pipelines on the articulated boom assembly and collect the hydraulic oil in the pipelines with a suitable vessel. Then seal the pipelines and ports.
5. Reliably support the upper and lower connectors with suitable lifting equipment.
6. Reliably support the lower linkage and upper linkage with suitable lifting equipment.
7. Remove the bolt and nut at the pivot pin #6 connecting the lower linkage with the lower connector, and knock out the pivot pin #6 with a brass rod and mallet.
8. Remove the screw at the pivot pin #9 connecting the lower linkage with the turntable, and knock out the pivot pin #9 with a brass rod and mallet.
9. Slowly remove the lower linkage with the aid of the lifting equipment.
10. Remove the screw at the pivot pin #1 connecting the upper linkage with the upper connector, and knock out the pivot pin #1 with a brass rod and

mallet.

11. Remove the bolt and nut at the pivot pin #3 connecting the upper linkage with the lower connector, and knock out the pivot pin #3 with a brass rod and mallet.
12. Slowly remove the upper linkage with the aid of the lifting equipment.
13. Reliably support the upper articulated boom with suitable lifting equipment.
14. Remove the retaining nut and bolt at the pin #2 connecting the upper connector with the upper articulated boom, and knock out the pivot pin #2 with a brass rod and mallet.
15. Slowly remove the upper connector with the aid of the lifting equipment.
16. Reliably support the lower articulated boom and pull rod with suitable lifting equipment.
17. Remove the articulated boom lift cylinder.
18. Remove the bolt and nut at the pivot pin #4 connecting the upper articulated boom with the lower connector, and knock out the pivot pin #4 with a brass rod and mallet.
19. Remove the bolt and nut at the pivot pin #5 connecting the upper articulated boom with the pull rod, and knock out the pivot pin #5 with a brass rod and mallet.
20. Slowly remove the upper articulated boom with the aid of the lifting equipment.
21. Remove the screw at the pivot pin #8 connecting the pull rod with the lower articulated boom, and knock out the pivot pin #8 with a brass rod and mallet.
22. Slowly remove the pull rod with the aid of the lifting equipment.
23. Remove the bolt and nut at the pivot pin #7 connecting the lower articulated boom with the lower connector, and knock out the pivot pin #7 with a brass rod and mallet.
24. Slowly remove the lower connector with the aid of the lifting equipment.
25. Remove the bolt and nut at the pivot pin #10 connecting the lower articulated boom with the turntable, and knock out the pivot pin #10 with a brass rod and mallet.
26. Slowly remove the articulated boom with the aid of the lifting equipment.

Installation

Follow the reverse order of the disassembly procedures.

Boom Slider

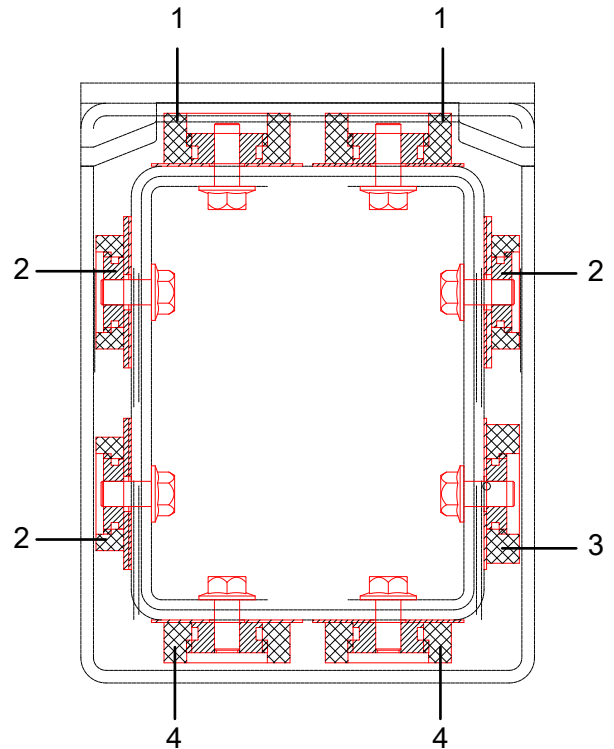

Fig 8 Diagram of sliders at boom head

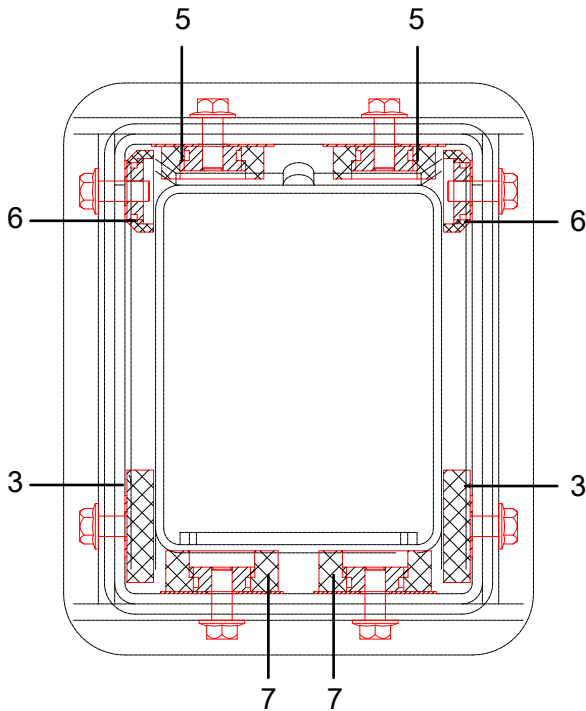

Fig 9 Diagram of sliders at boom tail

Table 6-3 Boom slider thickness

No.	Slider thickness
1	20mm (0.79in)
2	11mm (0.43in)
3	13mm (0.51in)
4	16mm (0.63in)

Table 6-3 Boom slider thickness (Continued)

No.	Slider thickness
5	16mm (0.63in)
6	13mm (0.51in)
7	20mm (0.79in)

The boom slider is essential for the safe operation of the machine. As a friction pair will develop between each slider and the telescopic boom surface, improper slider gaskets or continued use of extremely worn sliders may result in component damage and unsafe operation. It is recommended to check the boom slider thickness once a year or after 1000 hours of operation.

1. Remove the cover plate from the head of the main boom (near the turntable) or the nylon brush at the tail of the main boom (near the platform).
2. Measure the thickness of each slider at the head and tail of the main boom.
3. If the telescopic cylinder has sliders, measure the slider thickness after the telescopic cylinder is removed.
4. Compare the measured thickness value of each slider with the value specified in the above table, and replace the slider assembly in time if the wear extent of the slider is greater than or equal to 3mm (0.118in).

NOTICE

The disassembled slider cannot be reused and must be replaced with a new slider assembly.

Telescopic Cylinder

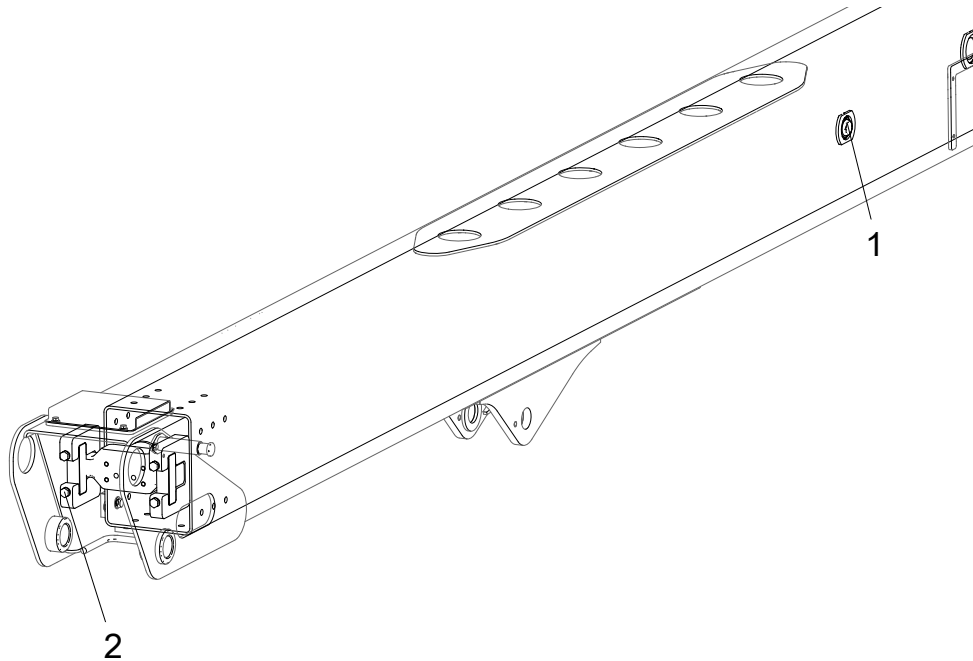

Fig 10 Telescopic cylinder

Disassembly

Follow the reverse order of the disassembly procedures.

1. Extend the telescopic boom until the telescopic cylinder pivot pin #1 is just accessible.
2. Remove the main boom and place it on a suitable support.
3. Remove the retaining ring at pivot pin #1 that secures the telescopic cylinder piston rod to the telescopic boom and knock out the pivot pin #1 with a brass rod and mallet.
4. Remove the bolt at pivot pin #2 that secures the telescopic cylinder to the base boom, and remove the stopper and gasket.
5. Use suitable lifting equipment to support the front end of the telescopic cylinder and carefully and slowly pull the cylinder out of the main boom head.

NOTICE

When pulling the telescopic cylinder out of the main boom, take extra care to avoid damaging other parts of the boom tube.

6. Before the telescopic cylinder is fully pulled out of the main boom, adjust the lifting equipment to provide sufficient support for the entire cylinder.
7. With the assistance of the lifting equipment, slowly remove the cylinder from the main boom and carefully place it on a suitable support.

Installation

This Page Intentionally Left Blank

7 HYDRAULIC SYSTEM

7.1 LAYOUT OF HYDRAULIC ELEMENTS

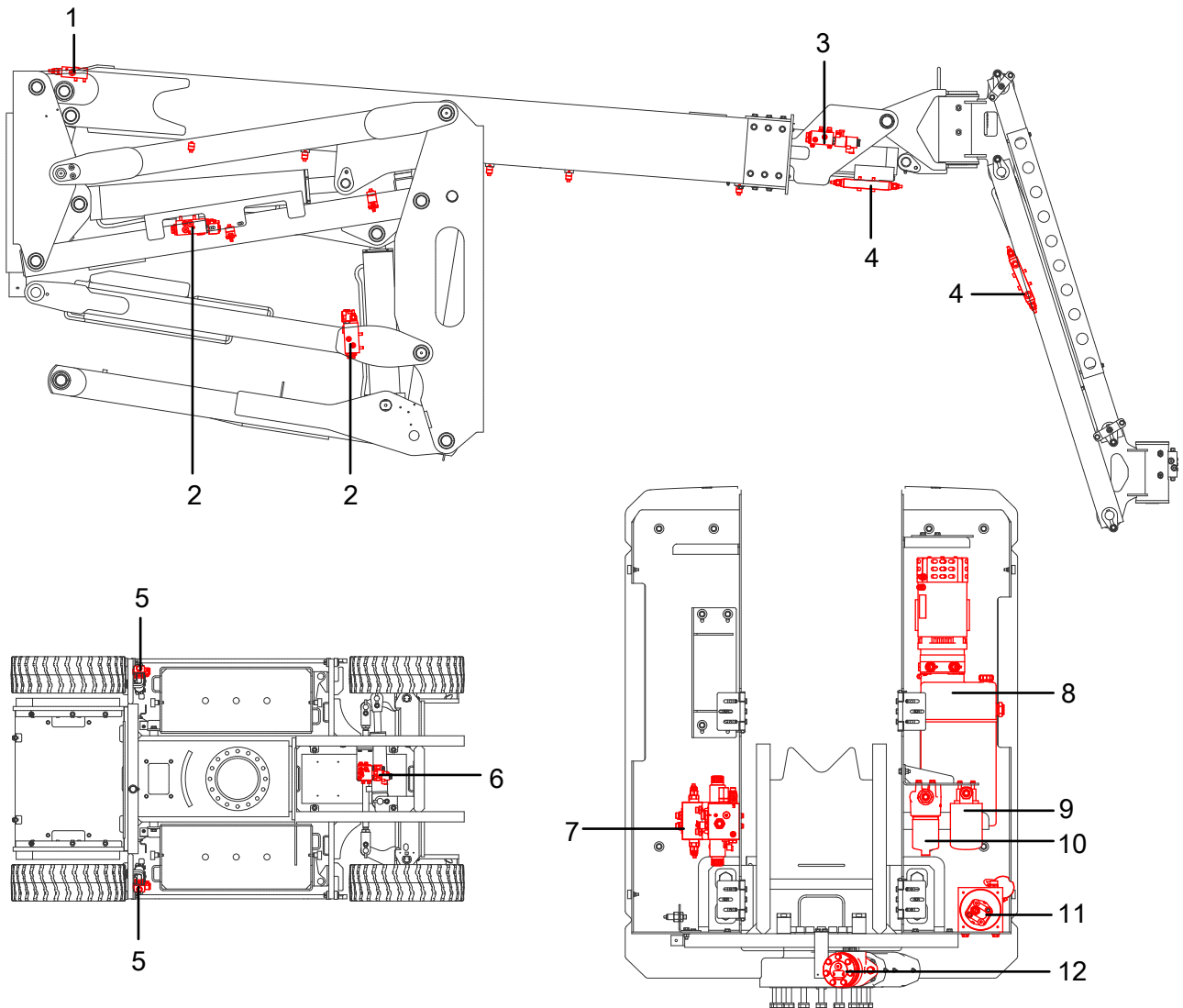

Fig 1

Table 7-1

1. Telescopic counterbalance valve	2. Luffing control valve	3. Platform control valve
4. Leveling counterbalance valve	5. Two-way hydraulic lock	6. Pothole control valve
7. Seven-section electric proportional multi-way valve	8. Power unit	9. Return filter
10. High-pressure filter	11. Emergency power unit	12. Cycloid motor

7.2 FUNCTION VALVES

Pothole Control Valve (PN.202040003546)

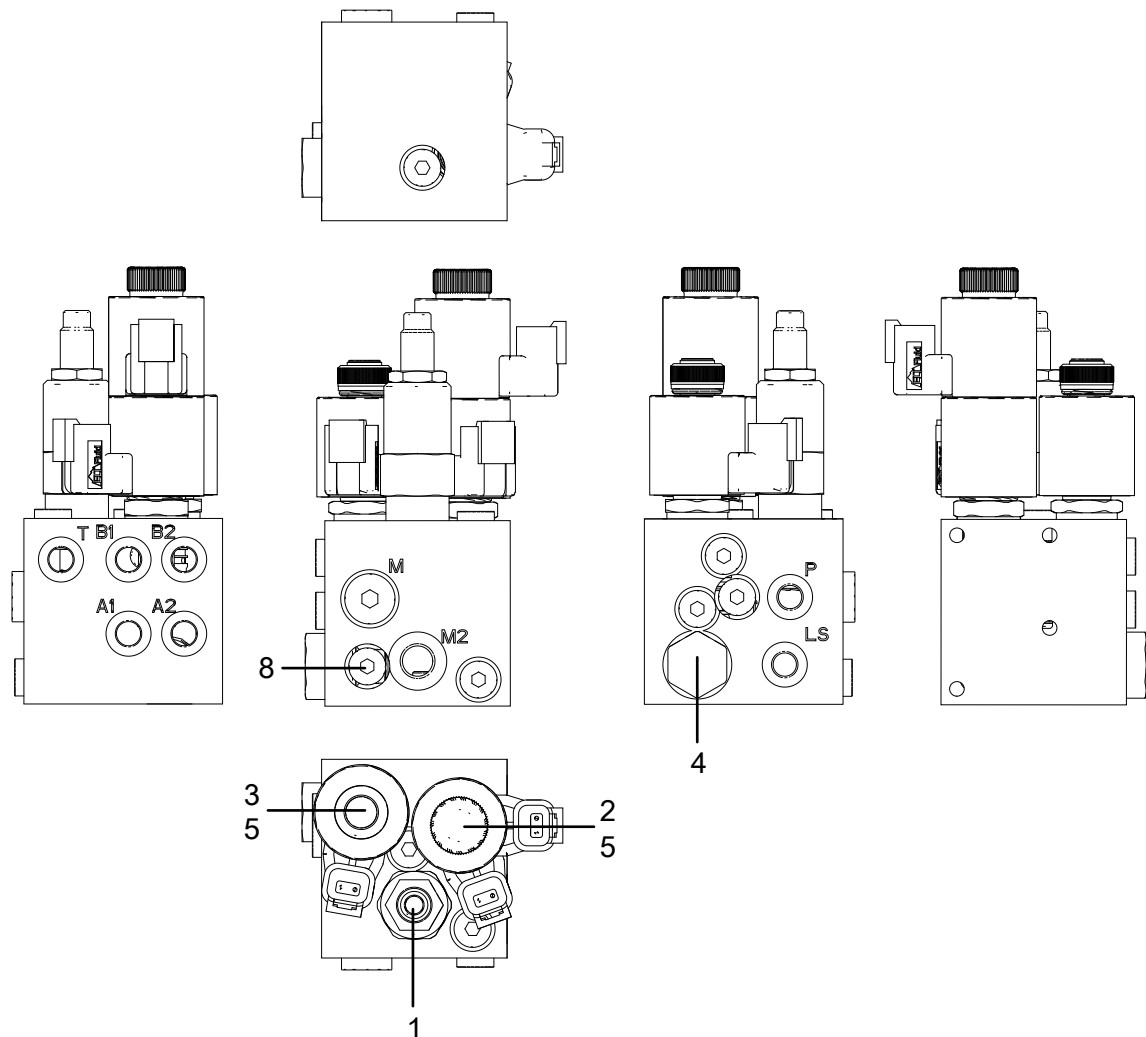

Fig 2 Pothole control valve (PN.202040003546)

Table 7-2 Pothole control valve (PN.202040003546)

No.	Name	Torque	Function
1	Pressure reducing valve	25.4Nm (19ft-lb)	Control pressure
2	Solenoid valve	24Nm (18ft-lb)	Control the extending and retracting of pothole protection device
3	Solenoid valve	24Nm (18ft-lb)	Limit the maximum pressure of pothole protection device
4	Check valve	22Nm (16ft-lb)	Keep oil flowing in one direction
5	Coil	\	\
8	Damper	\	\

Seven-section Electric Proportional Multi-way Valve (PN.202040003369)

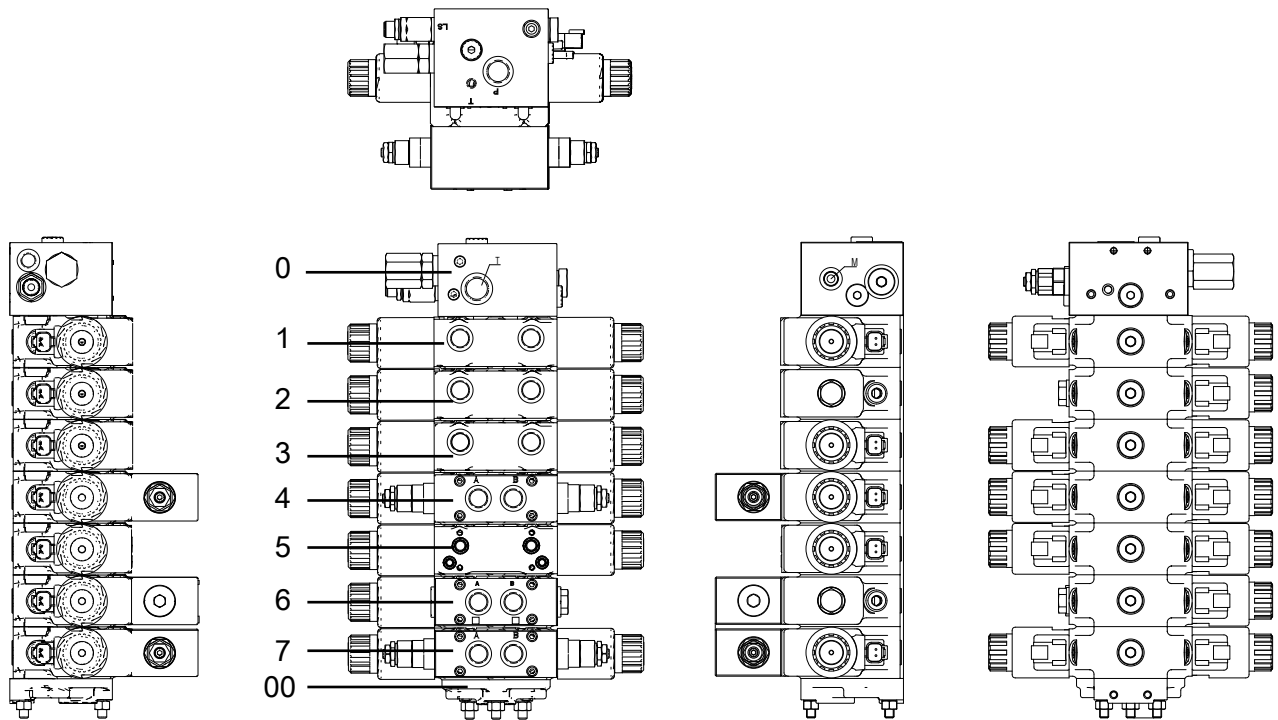

Fig 3 Seven-section electric proportional multi-way valve (PN.202040003369)

Table 7-3 Seven-section electric proportional multi-way valve (PN.202040003369)

No.	Name	Function
0	Oil inlet section	Limit the maximum pressure of main overflow valve; the fixed-differential overflow valve forms a fixed-displacement pump load-sensitive system to discharge excess oil from the fixed-differential overflow valve
1	Articulated boom luffing work section	Control articulated boom lifting/lowering
2	Main boom luffing work section	Control main boom lifting/lowering
3	Boom telescope work section	Control boom extending/retracting
4	Turntable slewing work section	Control the left/right slewing of turntable
5	Platform leveling work section	Control platform leveling upwards/downwards
6	Common proportion section	Provide oil sources for jib boom lifting/lowering and left/right swing of jib boom and platform
7	Steer work section	Control the wheels steering to left/right
00	End section	/

Luffing Control Valve (PN.202040003366)

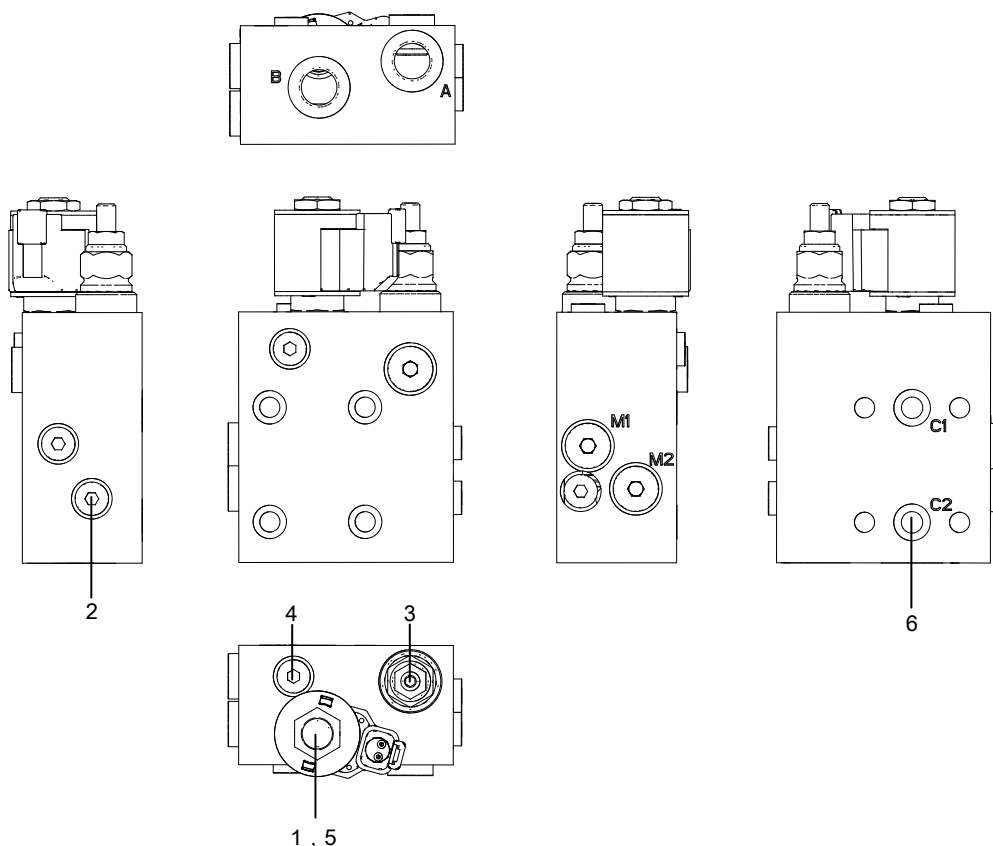

Fig 4 Luffing control valve (PN.202040003366)

Table 7-4 Luffing control valve (PN.202040003366)

No.	Name	Torque	Function
1	Solenoid valve	25.8 ~ 28.5Nm (19 ~ 21ft-lb)	Control the speed of lowering caused by dead weight
2	Damper	5Nm (4ft-lb)	\
3	Counterbalance valve	70 ~ 75Nm (52 ~ 55ft-lb)	Keep the load balanced
4	Damper	5Nm (4ft-lb)	\
5	Coil	4Nm (3ft-lb)	\
6	O-ring	\	\

Telescopic Counterbalance Valve (PN.202040003410)

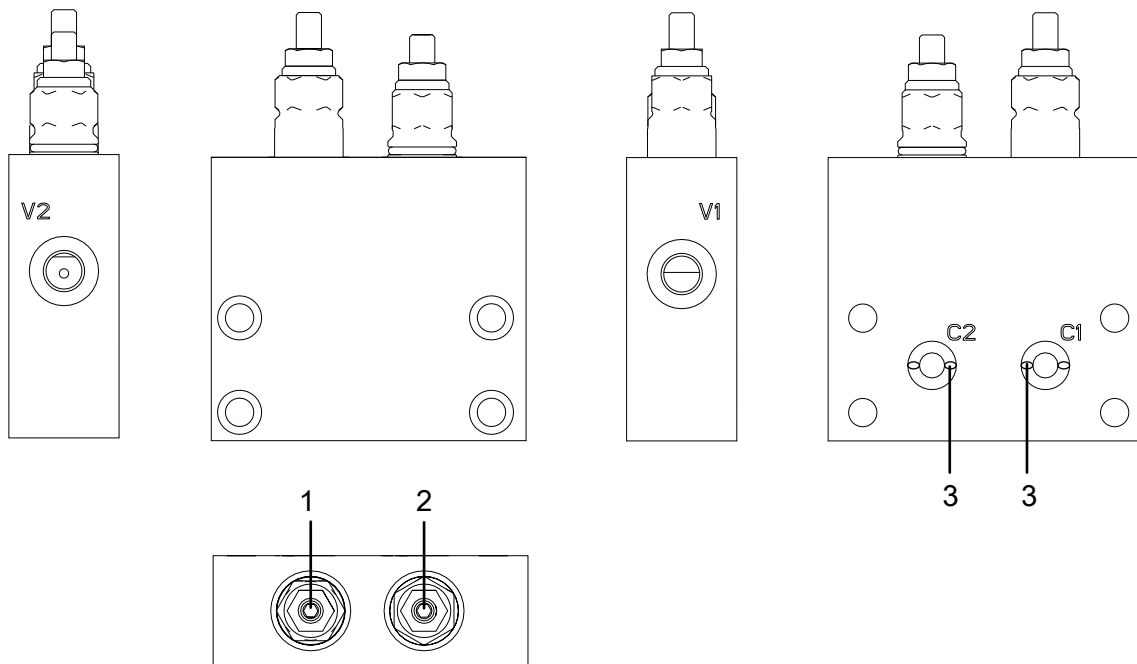

Fig 5 Telescopic counterbalance valve (PN.202040003410)

Table 7-5 Telescopic counterbalance valve (PN.202040003410)

No.	Name	Torque	Function
1	Counterbalance valve	40 ~ 45Nm (30 ~ 33ft-lb)	Keep the load balanced
2	Counterbalance valve	45 ~ 50Nm (33 ~ 37ft-lb)	Keep the load balanced
3	O-ring	\	\

Platform Control Valve Block (PN.202040003367)

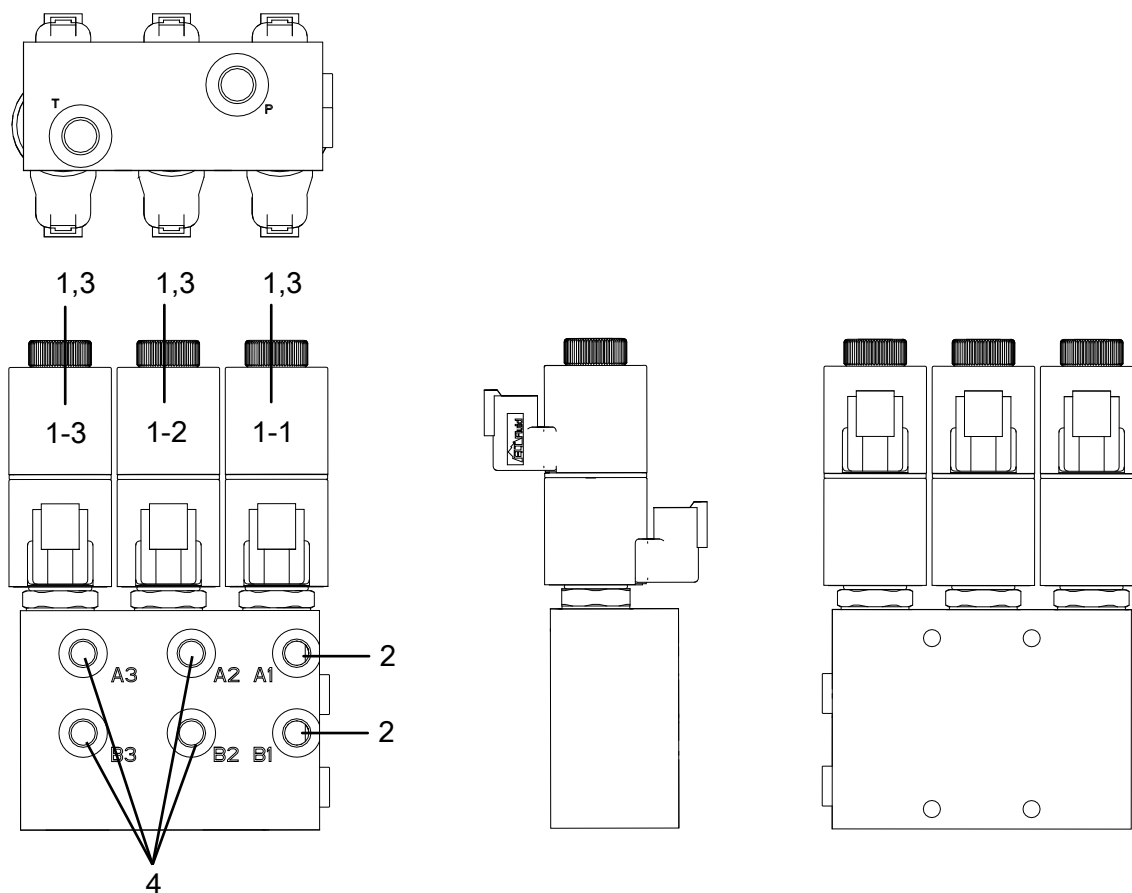

Fig 6 Platform control valve block (PN.202040003367)

Table 7-6 Platform control valve block

No.	Name	Torque	Function
1-1	Solenoid valve	30Nm (22ft-lb)	Control jib boom luffing direction
1-2	Solenoid valve	30Nm (22ft-lb)	Control jib boom rotation direction
1-3	Solenoid valve	30Nm (22ft-lb)	Control platform rotation direction
2	Damper	5Nm (3.7ft-lb)	\
3	Coil	4Nm (3ft-lb)	\
4	Damper	5Nm (3.7ft-lb)	\

Leveling Counterbalance Valve (PN.20204000011)

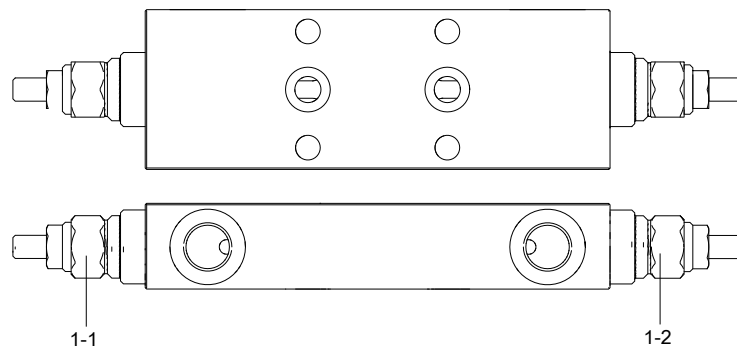

Fig 7 Leveling counterbalance valve (PN.20204000011)

Table 7-7 Leveling counterbalance valve (PN.20204000011)

No.	Name	Torque	Function
1	Counterbalance valve	70 ~ 75Nm (52 ~ 55ft-lb)	Keep the load balanced

7.3 POWER UNIT

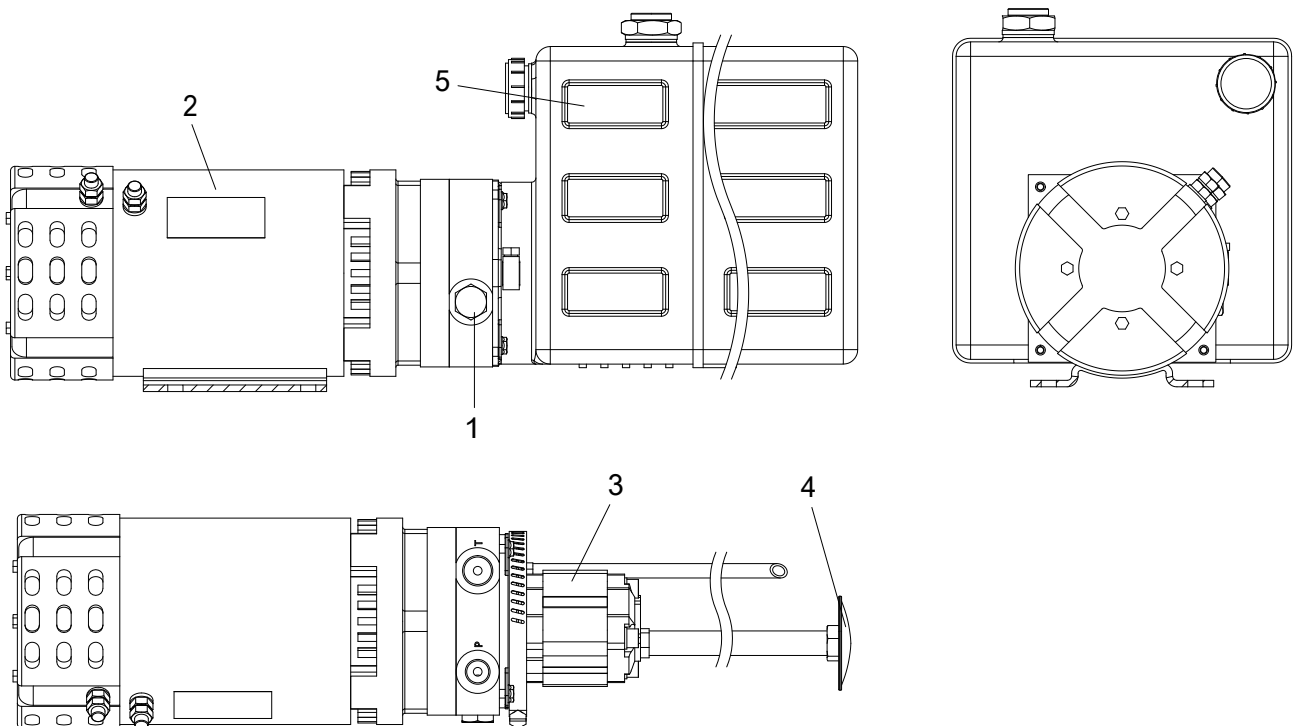

Fig 8 Power unit

Table 7-8

1. Check valve	2. DC motor	3. Gear pump
4. Oil inlet filter screen	5. Fuel tank	

Inspect Motor Carbon Brush

Checking and replacing the motor carbon brush regularly is essential for improving the operating stability of motor and extending its service life. It is recommended to check the motor carbon brush every 3 months or after 250 hours of operation.

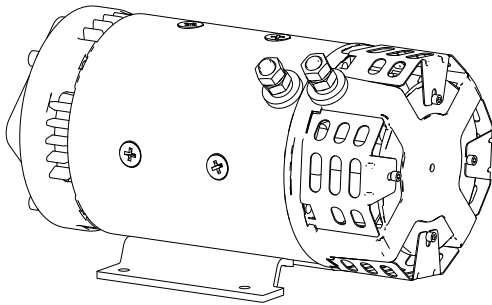

Fig 9 Diagram of motor

Check and replace the carbon brush

1. Remove the bolts on the back cover of motor.
2. Remove the back cover.
3. Remove the bolts from the back end cap.
4. Remove the mounting bolts on the carbon brush.
5. Use a hook to pull up the spring, and press and hold it to take out the old carbon brush.
6. Check the carbon brush for wear. If the brush becomes damaged or is close to or less than the minimum length, please replace the carbon brush. Take out the old carbon brush, clean the brush box, and put the new carbon brush into the brush box.
7. Put down the spring to press the carbon brush tightly.
8. Move the carbon brush to ensure the carbon brush can move freely inside the brush box.
9. Install the mounting bolt of carbon brush.
10. Install the mounting bolt of back end cap.
11. Install the back cover.

NOTICE

After the new motor is installed, idle the motor to fit in the arc surface of carbon brush so that the carbon brush comes in well contact with the reverser.

Clean the slip ring

1. Visually inspect the slip ring, which should be dark

brown in normal condition.

2. If the slip ring gets corroded or has uneven surface, please remove the belt, and turn the axle by hand to clean it. Use sand paper to clean the slip ring so that less material will be removed.
3. If the slip ring is deeply dented, replace with a new one instead of cleaning.

Suction Filter Screen

It is recommended to replace the suction filter screen every year or after 1000 hours of operation. The replacement interval should be shorter in harsh working environments.

NOTICE

Remove the hydraulic tank before replacing the suction filter screen.

Every time the hydraulic oil is replaced, the suction filter screen should also be replaced.

7.4 HYDRAULIC OIL

Check the Oil Level

Maintaining the hydraulic oil at the right level is essential for the normal operation of the machine. If the hydraulic oil level is too high, the oil will overflow from the oil tank during the operation of the machine; if the hydraulic oil level is too low, the oil pump will have entrained air during the operation of the machine and hydraulic components will be damaged.

1. Make sure the platform is in stowed position.
2. Open the right turntable cover and visually inspect the side of the hydraulic tank. The hydraulic oil level should be within 80%-85% of the oil capacity of the hydraulic tank.
3. If necessary, fill with correct hydraulic oil according to the **Oil Requirements**, and do not overfill the tank.
4. Check the hydraulic tank body and joints for leakage.

Check the Cleanliness of Hydraulic Oil

Check the hydraulic oil, and if any of the following conditions are found, replace the hydraulic oil:

- The hydraulic oil is milky white and cloudy.
- The hydraulic oil is black.
- Take some hydraulic oil and check it in the sun to find there are luminous metal spots, or rub the hydraulic oil with two fingers to find there are metal particles obviously.
- The hydraulic oil stinks.

Replace the Hydraulic Oil

It is recommended to replace the hydraulic oil every year or after 1000 hours of operation. The replacement interval should be shorter in harsh working environments.

NOTICE

Every time the hydraulic oil is replaced, the suction filter screen of the hydraulic tank must also be replaced.

1. Turn off the machine and make sure the hydraulic oil has cooled to room temperature.
2. Open the right turntable cover to locate the power unit.
3. Disconnect and plug the hydraulic tank suction pipe and return pipe.
4. Remove the retaining bolt and clamp on the side of the hydraulic tank, and then remove the hydraulic tank from the power unit.

NOTICE

Be extremely careful while removing the hydraulic tank; or the hydraulic tank inside and other components on the power unit may get damaged.

5. Drain the hydraulic oil in the hydraulic tank to an appropriate container.
6. After all hydraulic oil has been drained, clean the inside of the tank with a neutral solvent, and then drain the solvent.
7. After the hydraulic tank is dry, reinstall it to the power unit.
8. Reinstall the power unit to the right turntable cover.
9. Fill with correct hydraulic oil according to the **Oil Requirements**, and never overfill the tank.

7.5 HYDRAULIC OIL RETURN FILTER

It is recommended to replace the hydraulic oil return filter element after the first 50 hours of operation and every 3 months or 250 hours of operation thereafter. The replacement interval should be shorter in harsh working environments.

1. Turn off the machine.
2. Open the turntable cover and locate the return filter.
3. Place an appropriate oil-collecting vessel under the return filter.
4. Use a wrench to remove the filter housing.
5. Remove the filter element from the housing.
6. Check the seal on the mounting surface of the housing and, if necessary, replace the seal.
7. Install a new filter element into the housing and tighten it securely.
8. Clean the hydraulic oil spilled during the process.
9. Start the machine from the ground.
10. Check the return filter and related components for leakage.

7.6 HYDRAULIC OIL HIGH-PRESSURE FILTER

It is recommended to replace the hydraulic oil high-pressure filter element after the first 50 hours of operation and every 3 months or 250 hours of operation thereafter. The replacement interval should be shorter in harsh working environments.

1. Turn off the machine.
2. Open the turntable cover and locate the high-pressure filter.
3. Place an appropriate oil-collecting vessel under the high-pressure filter.
4. Use a wrench to remove the filter housing.
5. Remove the filter element from the housing.
6. Check the seal on the mounting surface of the housing and, if necessary, replace the seal.
7. Install a new filter element into the housing and tighten it securely.
8. Clean the hydraulic oil spilled during the process.
9. Start the machine from the ground.
10. Check the high-pressure filter and related components for leakage.

7.7 INSPECT CYLINDER DRIFT

The cylinder will drift down due to leakage, and the drift is normal within a certain range. In order to ensure the normal operation of the machine, it is recommended to conduct drift inspection on the platform every 3 months or after 250 hours of operation to determine whether cylinder drift inspection is required.

Fully extend the main boom and place the rated load on the platform to measure the drift from the platform to the ground with the machine powered off. If the platform drifts down more than 50mm (1.97in) in 10 minutes, carry out cylinder drift inspection as per the following procedures.

1. Place the cylinder in an environment with stable ambient temperature.
2. Make the cylinder apply normal cylinder load to the platform.
3. Measure drift at cylinder piston rod with a calibrated dial indicator.
4. The maximum allowable drift for cylinders with different bores is shown in the table below. If the measured value is less than the maximum allowable drift, the cylinder is working normally. If the measured value is greater than the maximum allowable drift, it indicates that the cylinder is not working normally. Contact qualified service technicians for inspection and repair.

Table 7-9 Maximum allowable drift for different cylinder bore

Cylinder bore diameter (mm/in)	Maximum allowable drift in 10 minutes (mm/in)
63/2.48	0.96/0.037
80/3.15	0.63/0.025
100/3.94	0.39/0.015
125/4.92	0.23/0.009
160/6.30	0.14/0.006
180/7.09	0.13/0.005
200/7.87	0.10/0.0038
220/8.66	0.08/0.0030

NOTICE

The data is based on cylinder leakage of 6 drops per minute. Since the hydraulic oil expands with heat and contracts with cold, the test value of cylinder drift may have a tolerance of 7/10000 for each temperature change of 1°C.

7.8 HYDRAULIC SYMBOLS

Table 7-10

Symbol	Description
	Filter
	Brake
	Emergency power unit
	Hydraulic motor
	Overflow valve
	3-position 4-way solenoid directional valve
	2-position 4-way solenoid directional valve
	Pressure gradient control valve
	Check valve

7.9 HYDRAULIC SCHEMATIC DIAGRAM

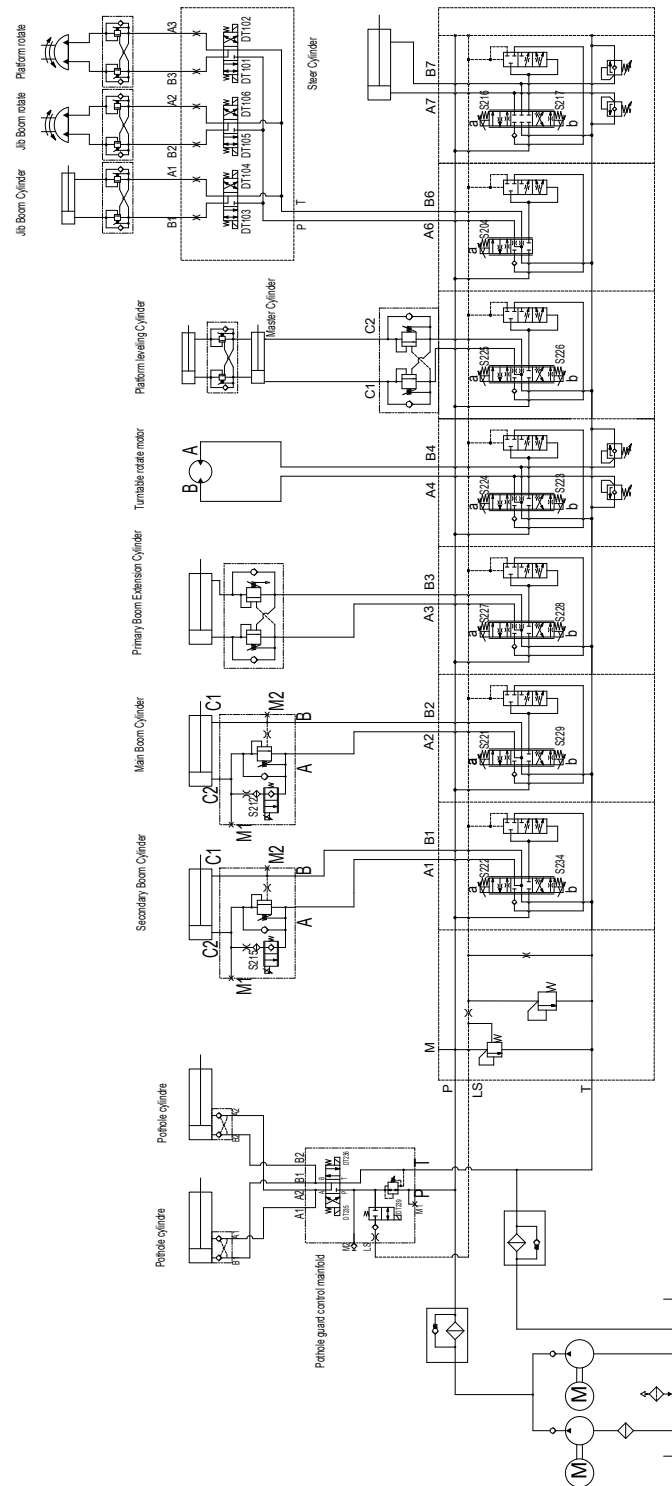

Fig 10 Hydraulic Schematic Diagram

This Page Intentionally Left Blank

8

ELECTRICAL SYSTEM

Eight 6V lead-acid batteries in series are used to drive the travel motor and hybrid motor to realize boom movement, turntable rotation and steering while traveling, and provide 12V control power for the whole machine through DC converter.

The batteries in one of the battery box are used to provide emergency power for the whole machine.

All batteries are charged via external power source. A power switch is used to protect the control system.

The maintenance of electrical equipment is essential for the proper and safe operation of the machine. If continuing to use the machine with electrical components damaged or corroded, it may lead to unsafe operation or serious personal injury.

8.1 BATTERY

The batteries used include 3 types: lead acid battery, lead acid maintenance-free battery and lithium battery, and the latter two batteries do not need maintenance.

Inspection

Battery condition will affect machine performance and operation, and the following checks should be performed on the battery at specified intervals.

- Check the battery level. The battery should not be discharged more than 80% of the total capacity, and should be charged immediately after each discharge.
- Check the harness retaining nuts between the battery cells. Make sure that the retaining nuts are tightened with the correct torque, and refer to the **Torque Specifications** section for the tightening torques.
- Check the battery harness connections. Make sure that the battery harness connections are firmly connected and not corroded, and the positive and negative poles are not reversed.

NOTICE

Improper connection may result in reduced performance and damaged terminals, fusion, or even fire.

- Check whether the inside and outside paint of the battery is damaged. If any damage is found, repair the paint immediately to protect the outer box insulation and avoid corrosion.

- Check the battery box for water accumulation. If any, blot up the accumulated water immediately.
- Clean the area around the battery regularly. Use cloths or brushes to regularly clean the top, terminals and connections of the battery with mixed liquid of baking soda and water, dry it with cloths after cleaning, and apply a thin layer of petroleum jelly or add terminal protectors to prevent cleaning solution from entering the battery.

NOTICE

Adding terminal protectors and anti-corrosion sealants will prevent the battery terminals and cables from corrosion.

The instructions below are applicable only for batteries requiring maintenance. Before performing inspection, please fully charge the battery and hold it still for 24 hours to equalize the battery cells.

1. Wear protective clothing, protective gloves and protective glasses.
2. Remove the battery vent cover.
3. Top up the hydrometer and drain it two or three times, and then take a sample from the battery electrolyte with the hydrometer.
4. Measure the specific gravity of all battery cells in sequence and note down the readings.
5. If the ambient temperature is above 27°C (80°F), add 0.004 to calibrate the specific gravity reading for every 5°C (40°F) higher; if the ambient temperature is below 27°C (80°F), reduce 0.004 to calibrate the specific gravity reading for every 5°C (40°F) lower.
 - Result 1: if the specific gravity reading of all battery cells is 1.250 or higher, and the reading difference between any two cells is less than 0.050, proceed with the next step.
 - Result 2: if the specific gravity reading of one or more battery cells is below 1.250, it indicates that the battery is running low and needs charging. After charging, measure the specific gravity reading, if it meets the Result 1, proceed with the next step.
 - Result 3: If the specific gravity reading difference between any two cells in the battery pack exceeds 0.050, equalize the battery pack and hold it still for 6 hours before re-measurement of the specific gravity readings. If satisfying the Result 1, proceed with the next step.

NOTICE

If the Result 1 cannot be met even after several attempts, the battery may have malfunctions.

6. Check the battery electrolyte level. Make sure the electrolyte level is at the right height and add distilled water to the required level if needed.
7. Install the battery vent cover.

Adding Water

NOTICE

- For lead-acid batteries (requiring maintenance), the electrolyte level should be checked after each charging, and if the level is found to be low, add water in time.
- The water shall be added after charging. Adding water before charging may cause acid overflow during charging.

- For batteries equipped with an automatic water refilling system, when the electrolyte is at the lowest level with the battery fully charged (the white dot of the battery observation hole is not at the top), add water immediately. It is recommended to use an automatic water refilling machine for refilling, with the operation steps as follows:
 1. Open the bucket cover of the water refilling machine.
 2. Add deionized water.
 3. Put back the bucket cover and connect the water refilling plug.
 4. Connect the quick connector between the water refilling machine and the battery and turn on the power switch to start automatic water refilling.
 5. After water refilling is completed, the automatic water refilling system will automatically stop.
 6. Turn off the power switch and disconnect the water refilling plug to complete water refilling.
- If the battery is not equipped with an automatic water refilling system, check the electrolyte level after charging. If the level is lower than the allowable height (the white dot of the battery observation hole is not at the top), wear gloves to add conforming distilled water or deionized water to the standard level

(1-2cm above the minimal level of the water filler plug). Never add any acid solution.

Equalization

Equalization is the deliberate process of overcharging the flooded/wet battery after it has been fully charged. Equalize the battery only when its specific gravity is low (less than 1.25) or its specific gravity exceeds the scope (greater than 0.030) after the battery is fully charged.

NOTICE

- Verify whether the battery is flooded/wet battery.
- To prevent battery damage, the battery must be equalized after a storage period of up to three months from the date of delivery.

1. Check the electrolyte level height to ensure that the level meets the specified requirements.
2. Verify that all vent caps are properly secured to the battery.
3. Set the charger to equalization mode.
4. Charge the battery in equalization mode. The battery will bleed air in the equalization process (forming bubbles).
5. Remove the vent cap every hour to measure the specific gravity of all battery cells, and stop the charging in equalization mode if the specific gravity doesn't increase any more.

Storage

- Fully charge the battery before storage.
- The battery should be stored in cool and dry environment (temperature 10°C-25°C/50-77°F, RH < 90%), and charged every 3 months using the charger provided by the manufacturer.
- Disconnect the main power switch to eliminate potential hazards that could cause electrical leakage of the battery.
- The battery will self-discharge gradually during storage. Monitor the specific gravity or the voltage every 4 ~ 6 weeks. The comparison of the state of charge, specific gravity and open-circuit voltage is shown in the following table.

Table 8-1

State of charge (%)	Specific gravity	Open-circuit voltage (V)		
		Battery cell	6V	12V
100	1.277	2.122	6.37	12.73
90	1.258	2.103	6.31	12.62
80	1.238	2.083	6.25	12.50
70	1.217	2.062	6.19	12.37
60	1.195	2.040	6.12	12.24
50	1.172	2.017	6.05	12.10
40	1.148	1.993	5.98	11.96
30	1.124	1.969	5.91	11.81
20	1.098	1.943	5.83	11.66
10	1.073	1.918	5.75	11.51

- Recharge the battery in quick charging mode when the battery level is 70% or lower.
- Recharge the battery before use after removing it from storage.
- Storage in hot environments (above 32°C/90°F): Direct exposure of the battery to heat sources should be avoided during battery storage, and the battery self-discharges faster at high temperatures. If storing the battery in hot summer months, monitor the specific gravity or voltage more frequently (approximately every 2-4 weeks).
- Storage in cold environments (below 0°C/32°F): Avoid placing batteries in places where the temperature is expected to reach the freezing point during storage, as batteries may freeze at low temperatures if not fully charged. If the battery is to be stored in the icy winter months, the battery must be fully charged.

NOTICE
<i>Do not store the battery more than 6 months in hot or cold environments.</i>

8.2 CHARGING FAULTS AND SOLUTIONS

Charging Faults and Solutions (Lead-acid Battery)

In case of charging failure, the 50% light, 75% light and 100% light will flash 1-6 times at the same time.

Table 8-2 Charging Faults and Solutions (Lead-acid Battery)

Fault code	Indication	Cause	Solution
E01 bAt	3 lights flash once	Output not connected to battery or reversely connected	Check the battery pack is properly connected. Check the charger is properly connected. Inspect the individual cells in the battery pack for damage.
E02 AC	3 lights flash two times	Abnormal utility supply (voltage)	Check the AC power cable is connected between the charger and AC outlet. Make sure that the AC plug is firmly inserted into the AC outlet.
E03 Hot	3 lights flash three times	Overtemp cutout of charger	When the charger inside or ambient temperature is too high, the charger will cut out and enter the overtemp cutout mode. Please place the charger in a well-ventilated site. Disconnect the charger and wait 15-20min before recharging.
E04 bAt	3 lights flash four times	Overtemp cutout of battery	When the battery temperature exceeds the preset value, the charger will cut out to prevent overheat. After the battery temperature drops, the charger will restart automatically.

Table 8-2 Charging Faults and Solutions (Lead-acid Battery) (Continued)

Fault code	Indication	Cause	Solution
E05 Err	3 lights flash five times	Output overcurrent	Return the battery for repair.
E06 bAt	3 lights flash six times	Battery overvoltage	Check and make sure the correct output battery voltage is connected.
E10 Err	/	Relay close timeout	Return the battery for repair.
E11 bAt	/	Charging failed	Recharge the battery after power-off.
		Battery cell damaged	Replace the battery.

Charging Faults and Solutions (Lithium Battery)

In case of charging faults, the red LED indicator light will flash.

Table 8-3 Charging faults and solutions (lithium battery)

Flashing times	Cause	Solution
1	Output not connected to the battery or connected reversely, short circuit, damaged cell	<ol style="list-style-type: none"> 1. Check that the battery pack is connected correctly. 2. Check that the regulated power supply is connected correctly. 3. Inspect the individual cells in the battery pack for damage.
2	Abnormal utility supply (voltage)	<ol style="list-style-type: none"> 1. Check that the AC power line is connected between the regulated power supply and the AC outlet. 2. Make sure that the AC plug is firmly inserted into the AC outlet.
3	High temperature protection for regulated power supply	<ol style="list-style-type: none"> 1. The temperature inside the regulated power supply or the ambient temperature is too high, the regulated power supply will shut down and enter the high-temperature protection mode. Place the regulated power supply in a well-ventilated environment. 2. Disconnect the regulated power supply, wait 15-20 minutes and then reconnect the power supply.
4	High temperature protection for battery	<ol style="list-style-type: none"> 1. When the battery temperature exceeds the preset value, the regulated power supply will turn off the output to prevent the battery from overheat. 2. After the battery temperature drops, the regulated power supply will automatically restart.
5	Excessively high output current	Return the battery for repair.
6	Excessively high battery voltage	Check and make sure the correct output battery voltage is connected.
8	Reading memory address error	Return the battery for repair.

Table 8-3 Charging faults and solutions (lithium battery) (Continued)

Flashing times	Cause	Solution
10	Relay unable to close	Return the battery for repair.
11	Battery error (damaged cell or battery system error)	Replace the battery.

8.3 FAULT CODES DESCRIPTION

Machine Fault Codes

In case of failure, query the fault code on the fault inquiry interface of the ground controller.

Table 8-4 Machine fault codes description

Fault code	Description	Cause	Solution
01	Platform communication fault	Abnormal communication between platform and ground controllers	Check the signal lines between platform and ground controllers, and ensure the power supply is normal.
02	Drive controller communication fault	Abnormal communication between drive and ground controllers	Check the signal lines between ground and drive controllers, and ensure the power supply is normal.
03	Turntable tilt alarm	Turntable tilt alarm	Check whether the machine tilts exceeding 5° or the level switch becomes disconnected
04	Overload alarm	Overload alarm	Check whether the platform load exceeds the rating.
05	Weighing sensor fault	Weighing sensor fault	Check whether the weighing sensor functions properly.
06	Drive joystick error	Drive joystick data error	Check the drive joystick data
07	Steer joystick error	Steer joystick data error	Check the steer joystick data
08	Main boom luffing joystick error	Main boom luffing joystick data error	Check the main boom luffing joystick data
09	Slewing joystick error	Slewing joystick data error	Check the slewing joystick data
10	Telescoping joystick error	Telescoping joystick data error	Check the telescoping joystick data
11	Jib rotation joystick error	Jib rotation joystick data error	Check the jib rotation joystick data
12	Hydraulic system pressure sensor error	Hydraulic system pressure sensor error	Check whether the hydraulic system pressure sensor functions properly
13	Level switch fault	Level switch fault	Check whether the level switch functions properly
14	Lift controller communication fault	Lift controller communication fault	Check the signal lines between platform and drive controllers, and ensure the power supply is normal.
15	Footswitch or enable switch 7-	Footswitch or enable switch 7-second limit alarm	Check whether the foot switch or enable switch function properly

Table 8-4 Machine fault codes description (Continued)

	second limit alarm		
16	Obstacle detection alarm	Obstacle detection alarm	Check whether the obstacle detection switch functions properly
17	Drive controller error alarm	Drive controller error alarm	Check the drive controller for error
18	Lift controller error alarm	Lift controller error alarm	Check the lift controller for error
19	Heavy load alarm	Heavy load alarm	Check the platform load and the actual measurement of sensor AD value
20	Envelope alarm	Envelope alarm	Check the boom position and the actual measurement of sensor AD value
21	Broken rope alarm	Broken rope alarm	Check the wire ropes of boom and the wiring of proximity switch
22	Weighing sensor comparison error	Weighing sensor comparison error	Check the actual values and AD values of weighing sensor 1 and 2, and check the wiring
23	Platform tilt alarm	Platform tilt alarm	Check whether the platform tilt angle exceeds the limit
24	Solenoid clutch fault	Solenoid clutch fault	Check whether the solenoid clutch functions properly or the wiring harness is disconnected
25	Turntable slewing left solenoid valve error	Turntable slewing left solenoid valve error	Check the wiring of turntable slewing left solenoid valve
26	Turntable slewing right solenoid valve fault	Turntable slewing right solenoid valve fault	Check the wiring of turntable slewing right solenoid valve
27	Main boom extending solenoid valve fault	Main boom extending solenoid valve fault	Check the wiring of main boom extending solenoid valve
28	Main boom retracting solenoid valve fault	Main boom retracting solenoid valve fault	Check the wiring of main boom retracting solenoid valve
29	Main boom lifting solenoid valve fault	Main boom lifting solenoid valve fault	Check the wiring of main boom lifting solenoid valve
30	Main boom lowering solenoid valve error	Main boom lowering solenoid valve error	Check the wiring of main boom lowering solenoid valve
31	Articulated boom lifting solenoid valve fault	Articulated boom lifting solenoid valve fault	Check the wiring of articulated boom lifting solenoid valve
32	Articulated boom lowering solenoid valve fault	Articulated boom lowering solenoid valve fault	Check the wiring of articulated boom lowering solenoid valve
33	Steer left solenoid valve fault	Steer left solenoid valve fault	Check the wiring of steer left solenoid valve
34	Steer right solenoid valve fault	Steer right solenoid valve fault	Check the wiring of steer right solenoid valve
35	Platform swing left solenoid valve fault	Platform swing left solenoid valve fault	Check the wiring of platform swing left solenoid valve

Table 8-4 Machine fault codes description (Continued)

36	Platform swing right solenoid valve fault	Platform swing right solenoid valve fault	Check the wiring of platform swing right solenoid valve
37	Platform leveling up solenoid valve fault	Platform leveling up solenoid valve fault	Check the wiring of platform leveling up solenoid valve
38	Platform leveling down solenoid valve fault	Platform leveling down solenoid valve fault	Check the wiring of platform leveling down solenoid valve
39	Jib up solenoid valve fault	Jib up solenoid valve fault	Check the wiring of jib up solenoid valve
40	Jib down solenoid valve fault	Jib down solenoid valve fault	Check the wiring of jib down solenoid valve
41	Function enable valve fault	Function enable valve fault	Check the wiring of function enable valve
42	Main boom anti-fall valve fault	Main boom anti-fall valve fault	Check the wiring of main boom anti-fall valve
43	Drive enable valve fault	Drive enable valve fault	Check the wiring of drive enable valve
44	Brake valve fault	Brake valve fault	Check the wiring of brake valve
45	Slewing enable valve fault	Slewing enable valve fault	Check the wiring of slewing enable valve
46	Front pump unloading valve fault	Front pump unloading valve fault	Check the wiring of front pump unloading valve
47	Rear pump unloading valve fault	Rear pump unloading valve fault	Check the wiring of rear pump unloading valve
48	Electrically proportional relief valve fault	Electrically proportional relief valve fault	Check the wiring of electrically proportional relief valve
49	Articulated boom angle sensor comparison error	Articulated boom angle sensor comparison error	Check whether the articulated boom angle sensor is correctly installed
50	Articulated boom angle sensor fault	Articulated boom angle sensor fault	Check the wiring of articulated boom angle sensor
51	Main boom angle sensor comparison error	Main boom angle sensor comparison error	Check whether the main boom angle sensor is correctly installed
52	Main boom angle sensor fault	Main boom angle sensor fault	Check the wiring of main boom angle sensor
53	Articulated boom relative angle sensor comparison error	Articulated boom relative angle sensor comparison error	Check whether the articulated boom relative angle sensor is correctly installed
54	Articulated boom relative angle sensor fault	Articulated boom relative angle sensor fault	Check the wiring of articulated boom relative angle sensor
55	Main boom relative angle sensor comparison error	Main boom relative angle sensor comparison error	Check whether the main boom relative angle sensor is correctly installed

Table 8-4 Machine fault codes description (Continued)

56	Main boom relative angle sensor fault	Main boom relative angle sensor fault	Check the wiring of main boom relative angle sensor
57	Low battery level alarm	Low battery level alarm	Check whether the battery voltage is too low
58	Front right steer sensor fault	Front right steer sensor fault	Check the wiring of front right steer sensor
59	Clutch fault	Clutch fault	Check whether the clutch can be properly engaged or the sensor is correctly wired.
60	Low fuel level fault	Low fuel level fault	Check whether the fuel level is too low or the sensor is correctly wired.

Motor Controller Fault Codes

Table 8-5 General fault codes of motor controller

Fault code	Description	Cause	Solution
0012	Overcurrent of pump motor	<ol style="list-style-type: none"> 1. Encoder fault or circuit interference; 2. Motor UVW short-circuited; 3. Mismatched motor parameters; 4. Controller fault. 	<ol style="list-style-type: none"> 1. Check the encoder surface for stains, replace it if necessary; 2. Check the motor UVW 3-phase cable for short circuit or damage, and check the controller UVW 3-phase cable for damage using a multimeter; 3. Monitor the controller current when fully loaded, re-match the motor if necessary; 4. If no problem is found in the above inspections, replace the controller.
0112	Overcurrent of FL motor controller		
0212	Overcurrent of FR motor controller		
0312	Overcurrent of RL motor controller		
0412	Overcurrent of RR motor controller		
0013	Current sensor fault of pump motor controller	<ol style="list-style-type: none"> 1. Motor UVW short-circuited; 2. Current sensor of the controller faulted. 	<ol style="list-style-type: none"> 1. Check the UVW 3-phase cable for short circuit or current leakage; 2. If no problem is found in the above inspections, replace the controller.
0113	Current sensor fault of FL motor controller		
0213	Current sensor fault of FR motor controller		
0313	Current sensor fault of RL motor controller		
0413	Current sensor fault of RR motor controller		
0014	Pre-charging fault of pump motor controller	<ol style="list-style-type: none"> 1. Voltage drop due to loads connected to B+ circuit; 2. Controller damaged. 	<ol style="list-style-type: none"> 1. Check whether other high-power loads are connected to the controller B+ circuit; 2. Check the KSI wiring, and measure the voltage using a multimeter to check for abnormality; 3. If no problem is found in the above inspections, replace the controller.
0114	Pre-charging fault of FL motor controller		
0214	Pre-charging fault of FR motor controller		
0314	Pre-charging fault of RL motor controller		
0414	Pre-charging fault of RR motor controller		

Table 8-5 General fault codes of motor controller (Continued)

Fault code	Description	Cause	Solution
0015	Low temperature of pump motor controller	The controller operates at ambient temperatures below -40 °C.	<ol style="list-style-type: none"> 1. Raise the ambient temperature above -40 °C, restart the key switch and interlock switch; 2. If no problem is found in the above inspections, replace the controller.
0115	Low temperature of FL motor controller		
0215	Low temperature of FR motor controller		
0315	Low temperature of RL motor controller		
0415	Low temperature of RR motor controller		
0016	High temperature of pump motor controller	<ol style="list-style-type: none"> 1. Controller temperature over 95°C; 2. Machine overloaded and motor non-matched; 3. Controller damaged. 	<ol style="list-style-type: none"> 1. Check the cooling measures of controller; 2. Monitor the operating current of controller (monitor/controller menu/current), re-match the motor if the current is too high, reset the turning point and slip value, properly restrict the current if needed. 3. If no problem is found in the above inspections, replace the controller.
0116	High temperature of FL motor controller		
0216	High temperature of FR motor controller		
0316	High temperature of RL motor controller		
0416	High temperature of RR motor controller		
0017	Severe undervoltage of pump motor controller	<ol style="list-style-type: none"> 1. Battery data setup error; 2. Excessive battery resistance; 3. Damaged fuse; 4. Damaged main contactor. 	<ol style="list-style-type: none"> 1. Measure the battery voltage and KSI and B+ circuits voltage with a multimeter; 2. Check the fuse and contactor; 3. Check the battery system voltage (programme/battery menu nominal voltage) and (user undervoltage) undervoltage setting. 4. If the drive controller fails, main contactor not engaged, the pump controller will report the fault 1.7.
0117	Severe undervoltage of FL motor controller		
0217	Severe undervoltage of FR motor controller		
0317	Severe undervoltage of RL motor controller		
0417	Severe undervoltage of RR motor controller		
0018	Severe overvoltage of pump motor controller	<ol style="list-style-type: none"> 1. Battery data setup error; 2. Excessive battery resistance; 3. Battery disconnected when regenerative brake engages. 	<ol style="list-style-type: none"> 1. Check the battery with a multimeter for proper voltage; 2. Check the fuse and contactor; 3. Check the battery system voltage (programme/battery menu nominal voltage) and (user undervoltage) undervoltage setting. 4. Check the regenerative brake current limit setting (programme/current limits menu regen current limit).
0118	Severe overvoltage of FL motor controller		
0218	Severe overvoltage of FR motor controller		
0318	Severe overvoltage of RL motor controller		
0418	Severe overvoltage of RR motor controller		
0021	Declined battery current of pump motor controller	Activated battery current attenuation	The power generation current limit value sent by the host computer is less than the actual value.
0121	Declined battery current of FL motor controller		

Table 8-5 General fault codes of motor controller (Continued)

Fault code	Description	Cause	Solution
0221	Declined battery current of FR motor controller		
0321	Declined battery current of RL motor controller		
0421	Declined battery current of RR motor controller		
0022	Reduced over-temperature performance of pump motor controller	The controller operates in hostile environment with the radiator blade temperature higher than 85°C	<ol style="list-style-type: none"> 1. Use the machine under normal operating conditions to increase the cooling effect of controller. 2. If the ambient temperature is normal, check the controller current which may cause an abrupt rise in temperature if being too high.
0122	Reduced over-temperature performance of FL motor controller		
0222	Reduced over-temperature performance of FR motor controller		
0322	Reduced over-temperature performance of RL motor controller		
0422	Reduced over-temperature performance of RR motor controller		
0023	Reduced undervoltage performance of pump motor controller	<ol style="list-style-type: none"> 1. Low battery level; 2. Battery data setup error; 3. Battery aging. 	<ol style="list-style-type: none"> 1. Check the battery with a multimeter for proper voltage; 2. Check the fuse and contactor; 3. Check the battery system voltage (programme/battery menu nominal voltage) and (user undervoltage) undervoltage setting.
0123	Reduced undervoltage performance of FL motor controller		
0223	Reduced undervoltage performance of FR motor controller		
0323	Reduced undervoltage performance of RL motor controller		
0423	Reduced undervoltage performance of RR motor controller		
0024	Reduced overvoltage performance of pump motor controller	<ol style="list-style-type: none"> 1. Battery data setup error; 2. Regenerative brake current results in voltage rise. 	<ol style="list-style-type: none"> 1. Check the battery with a multimeter for proper voltage; 2. Check the fuse and contactor; 3. Check the battery system voltage (programme/battery menu nominal voltage) and (user undervoltage) undervoltage setting. 4. Check the regenerative brake current limit setting (programme/current limits menu regen current limit).
0124	Reduced overvoltage performance of FL motor controller		
0224	Reduced overvoltage performance of FR motor controller		
0324	Reduced overvoltage performance of RL motor controller		

Table 8-5 General fault codes of motor controller (Continued)

Fault code	Description	Cause	Solution
0424	Reduced overvoltage performance of RR motor controller		
0025	Invalid 5V internal power supply of pump motor controller	Externally connected device fault	<ol style="list-style-type: none"> 1. Check the externally connected device for damage; 2. Using handhold unit check the device (monitor/outputs menu/5 Volts); 3. Disconnect externally connected 5V devices, if the fault still exists, replace the external devices. <p>Note: The pin #26 of the 35-pin controller connector is for 5V output.</p>
0125	Invalid 5V internal power supply of FL motor controller		
0225	Invalid 5V internal power supply of FR motor controller		
0325	Invalid 5V internal power supply of RL motor controller		
0425	Invalid 5V internal power supply of RR motor controller		
0026	Driver 6 output error of pump motor controller	Externally connected device fault	<ol style="list-style-type: none"> 1. Using handhold unit, monitor the output (monitor/digital out6) to find out the driver 6 signal output percentage; 2. Check the drive device of driver 6 for malfunctions, correct wiring, and current not exceeding 1A. <p>Note: The pin #19 of the 35-pin controller connector is for driver 6 output.</p>
0126	Driver 6 output error of FL motor controller		
0226	Driver 6 output error of FR motor controller		
0326	Driver 6 output error of RL motor controller		
0426	Driver 6 output error of RR motor controller		
0027	Driver 7 output overcurrent of pump motor controller	Externally connected device fault	<ol style="list-style-type: none"> 1. Using handhold unit, monitor the output (monitor/digital out7), to inspect the driver 7 signal output percentage; 2. Check the drive device of driver 7 for malfunctions, correct wiring, and current not exceeding 1A. <p>Note: The pin #20 of the 35-pin controller connector is for driver 7 output.</p>
0127	Driver 7 output overcurrent of FL motor controller		
0227	Driver 7 output overcurrent of FR motor controller		
0327	Driver 7 output overcurrent of RL motor controller		
0427	Reduced overheat performance of RR motor controller		
0028	Reduced overheat performance of pump motor controller	<ol style="list-style-type: none"> 1. Motor temperature reaching the preset limit; 2. Improper motor temperature setup. 	<ol style="list-style-type: none"> 1. Check the motor temperature sensor for damage; 2. Check the overheat performance attenuation value setup (programme/motor menu/temperature control temperature hot) for error; 3. Monitor the machine operating current to determine whether the overheat results from an excessively high current, re-match
0128	Reduced overheat performance of FL motor controller		
0228	Reduced overheat performance of FR motor controller		

Table 8-5 General fault codes of motor controller (Continued)

Fault code	Description	Cause	Solution
0328	Reduced overheat performance of RL motor controller		the motor if necessary. Note: The pins #7 and #8 of the 35-pin controller connector are for motor temperature sensor.
0428	Reduced overheat performance of RR motor controller		
0029	Temperature sensor fault of pump motor controller	<ol style="list-style-type: none"> Motor temperature sensor fault; Motor temperature sensor type setup error. 	<ol style="list-style-type: none"> Check the wiring of motor temperature sensor; Check the setup of motor temperature sensor (programme/motor menu/temperature control sensor type). Replace the motor temperature sensor. <p>Note: The pins #7 and #8 of the 35-pin controller connector are for motor temperature sensor.</p>
0129	Temperature sensor fault of FL motor controller		
0229	Temperature sensor fault of FR motor controller		
0329	Temperature sensor fault of RL motor controller		
0429	Temperature sensor fault of RR motor controller		
0031	Open/short-circuited driver 1 output/main contactor of pump motor controller	<ol style="list-style-type: none"> Driver 1 wiring fault; Loading device fault; Contactor fault. 	<ol style="list-style-type: none"> Check if the wiring is correct and pins are stained or damaged; Monitor output signal (monitor menu/outputs menu/Driver 1 PWM) to check whether there is output control signal; Check the coil of contactor; Replace the contactor. <p>Note: The pin #6 of the 35-pin controller connector is for driver 1 output.</p>
0131	Open/short-circuited driver 1 output/main contactor of FL motor controller		
0231	Open/short-circuited driver 1 output/main contactor of FR motor controller		
0331	Open/short-circuited driver 1 output/main contactor of RL motor controller		
0431	Open/short-circuited driver 1 output/main contactor of RR motor controller		
0032	Open/short-circuited driver 2 of pump motor controller	<ol style="list-style-type: none"> Driver 2 wiring fault; Loading device fault; Contactor fault. 	<ol style="list-style-type: none"> Check if the wiring is correct and pins are stained or damaged; Monitor output signal (monitor menu/outputs menu/Driver 2 PWM) to check whether there is output control signal; Check the coil of contactor; Replace the contactor. <p>Note: The pin #5 of the 35-pin controller connector is for driver 2 output.</p>
0132	Open/short-circuited driver 2 of FL motor controller		
0232	Open/short-circuited driver 2 of FR motor controller		
0332	Open/short-circuited driver 2 of RL motor controller		
0432	Open/short-circuited driver 2 of RR motor controller		
0033	Open/short-circuited solenoid brake/coil 3 output of pump motor controller	<ol style="list-style-type: none"> Open/short circuited coil of solenoid brake; Stained/damaged/broken wiring. 	<ol style="list-style-type: none"> Check if the wiring is correct and pins are stained or damaged; Monitor output signal (monitor menu/outputs menu/Driver 3 PWM) to check whether there is output control signal;
0133	Open/short-circuited solenoid brake/coil 3 output of FL motor controller		

Table 8-5 General fault codes of motor controller (Continued)

Fault code	Description	Cause	Solution
0233	Open/short-circuited solenoid brake/coil 3 output of FR motor controller		3. Check the coil of contactor; 4. Replace the solenoid brake. Note: The pin #4 of the 35-pin controller connector is for driver 3 output.
0333	Open/short-circuited solenoid brake/coil 3 output of RL motor controller		
0433	Open/short-circuited solenoid brake/coil 3 output of RR motor controller		
0034	Open/short-circuited coil 4 output of pump motor controller	1. Open/short-circuited coil 4; 2. Stained/damaged/broken wiring.	1. Check if the wiring is correct and pins are stained or damaged; 2. Monitor output signal (monitor menu/outputs menu/Driver 4PWM) to check whether there is output control signal; 3. Check the driver coil.
0134	Open/short-circuited coil 4 output of FL motor controller		
0234	Open/short-circuited coil 4 output of FR motor controller		
0334	Open/short-circuited coil 4 output of RL motor controller		
0434	Open/short-circuited coil 4 output of RR motor controller		
0035	Proportional drive error of pump motor controller	1. Open/short-circuited loading device; 2. Stained/damaged/broken wiring; 3. Improper wiring.	1. Check if the wiring is correct and pins are stained or damaged; 2. Monitor output signal “monitor menu/outputs menu/PD PWM” to check whether there is output control signal; 3. Check the loading devices, such as the driver coil, for damage.
0135	Proportional drive error of FL motor controller		
0235	Proportional drive error of FR motor controller		
0335	Proportional drive error of RL motor controller		
0435	Proportional drive error of RR motor controller		
0036	Encoder error of pump motor controller	1. Failed power supply of encoder; 2. Damaged encoder; 3. Improper wiring.	1. Check the encoder power supply; 2. Check the pulse count of encoder setup (programme/motor menu/encoder steps); 3. Check the encoder feedback speed signals (monitor/motor menu/motor speed A/B); 4. If the inspections above fail to discover the problem, replace the motor. Note: The pins #31 and #32 of the 35-pin controller connector are for encoder AB phase output signals.
0136	Encoder error of FL motor controller		
0236	Encoder error of FR motor controller		
0336	Encoder error of RL motor controller		
0436	Encoder error of RR motor controller		
0037	Open-circuited pump motor controller	1. Missing phase in motor; 2. Improper wiring;	1. Ensure the UVW 3-phase wiring not open-circuited; 2. Use a multimeter to check the UVW power
0137	Open-circuited FL motor controller		

Table 8-5 General fault codes of motor controller (Continued)

Fault code	Description	Cause	Solution
0237	Open-circuited FR motor controller	3. Controller damaged.	module works properly; 3. If the inspections above fail to discover the problem, replace the motor.
0337	Open-circuited RL motor controller		
0437	Open-circuited RR motor controller		
0038	Fused main contactor of pump motor controller	1. Fused contact of main contactor; 2. Improper wiring.	1. Check the main contactor for fused contact; 2. Measure the coil voltage for abnormality; 3. Check for correct wiring; 4. If the motor has missed phase, check the UV phase for unlinked cable.
0138	Fused main contactor of FL motor controller		
0238	Fused main contactor of FR motor controller		
0338	Fused main contactor of RL motor controller		
0438	Fused main contactor of RR motor controller		
0039	Main contactor engaging failure of pump motor controller	1. Large voltage drop in KSI voltage and battery voltage; 2. An element with high power is connected in series in the KSI circuit, which brings the voltage drop; 3. Contactor damaged.	1. Use a handhold to monitor the KSI, ensure the difference between the capacitor voltage (monitor/outputs menu capacitor Voltage) and the key switch voltage (Keyswitch Voltage) is less than the threshold (programme/main contactor/main DNC threshold). 2. Check whether an element with high power is connected in the KSI circuit, which brings the voltage drop; 3. Replace the contactor to find out if it is damaged.
0139	Main contactor engaging failure of FL motor controller		
0239	Main contactor engaging failure of FR motor controller		
0339	Main contactor engaging failure of RL motor controller		
0439	Main contactor engaging failure of RR motor controller		
0041	High voltage at slider end of accelerator of pump motor controller	1. Accelerator wiring disconnected; 2. Excessively high output voltage at slider end of accelerator.	Measure the output voltage at the slider end of accelerator to check if it is too high, replace the accelerator if necessary. Note: The pin #16 of the 35-pin controller connector is for accelerator slider end input.
0141	High voltage at slider end of accelerator of FL motor controller		
0241	High voltage at slider end of accelerator of FR motor controller		
0341	High voltage at slider end of accelerator of RL motor controller		
0441	High voltage at slider end of accelerator of RR motor controller		
0042	Low voltage at slide end of accelerator of pump motor controller	Excessively low output voltage at slider end of accelerator.	Measure the output voltage at the slider end of accelerator to check if it is too low, replace the accelerator if necessary. Note: The pin #16 of the 35-pin controller connector is for accelerator slider end input.
0142	Low voltage at slider end of		

Table 8-5 General fault codes of motor controller (Continued)

Fault code	Description	Cause	Solution
	accelerator of FL motor controller		
0242	Low voltage at slider end of accelerator of FR motor controller		
0342	Low voltage at slider end of accelerator of RL motor controller		
0442	Low voltage at slider end of accelerator of RR motor controller		
0043	High voltage at slider end of pot2 of pump motor controller	Excessively high output voltage at slider end of pot2.	Measure the voltage at the slider end of pot2, replace it if necessary. Note: The pin #17 of the 35-pin controller connector is for pot2 slider end input.
0143	High voltage at slider end of pot2 of FL motor controller		
0243	High voltage at slider end of pot2 of FR motor controller		
0343	High voltage at slider end of pot2 of RL motor controller		
0443	High voltage at slider end of pot2 of RR motor controller		
0044	Low voltage at slider end of pot2 of pump motor controller	Excessively low output voltage at slider end of pot2.	Measure the voltage at the slider end of pot2, replace it if necessary. Note: The pin #17 of the 35-pin controller connector is for pot2 slider end input.
0144	Low voltage at slider end of pot2 of FL motor controller		
0244	Low voltage at slider end of pot2 of FR motor controller		
0344	Low voltage at slider end of pot2 of RL motor controller		
0444	Low voltage at slider end of pot2 of RR motor controller		
0045	Pot-low overcurrent of pump motor controller	Excessively low resistance of potentiometer.	Overcurrent at potentiometer low end, replace it if necessary
0145	Pot-low overcurrent of FL motor controller		
0245	Pot-low overcurrent of FR motor controller		
0345	Pot-low overcurrent of RL motor controller		
0445	Pot-low overcurrent of RR motor controller		
0046	Invalid EEPROM of pump motor controller	<ol style="list-style-type: none"> 1. Software error; 2. Controller fault. 	<ol style="list-style-type: none"> 1. Download the correct software version; 2. Replace the controller.

Table 8-5 General fault codes of motor controller (Continued)

Fault code	Description	Cause	Solution
0146	Invalid EEPROM of FL motor controller		
0246	Invalid EEPROM of FR motor controller		
0346	Invalid EEPROM of RL motor controller		
0446	Invalid EEPROM of RR motor controller		
0047	Operation sequence error of pump motor controller	<ol style="list-style-type: none"> 1. Input sequence error of key switch, interlock switch, directional switch and accelerator; 2. Failure of key switch, interlock switch, directional switch and accelerator; 3. Improper wiring. 	<ol style="list-style-type: none"> 1. Check the input sequence of switches to exclude the operation-induced cause; 2. Use a handhold unit to check each switch condition; 3. Use a handhold unit to check the accelerator signal; 4. Replace the failed switches.
0147	Operation sequence error of FL motor controller		
0247	Operation sequence error of FR motor controller		
0347	Operation sequence error of RL motor controller		
0447	Operation sequence error of RR motor controller		
0049	Setup change of pump motor controller	The key switch must be restarted after setup change of some parameters.	Restart the key switch to eliminate the fault.
0149	Setup change of FL motor controller		
0249	Setup change of FR motor controller		
0349	Setup change of RL motor controller		
0449	Setup change of RR motor controller		
0068	VCL run error of pump motor controller	Software problem	<ol style="list-style-type: none"> 1. Update the software to the correct version; 2. Replace the controller.
0168	VCL run error of FL motor controller		
0268	VCL run error of FR motor controller		
0368	VCL run error of RL motor controller		
0468	VCL run error of RR motor controller		
0069	Power supply of pump motor controller exceeding the range	<ol style="list-style-type: none"> 1. Excessively high/low current of external loads; 2. Check the setup. 	<ol style="list-style-type: none"> 1. Check the external loads of 5V and 12V loading devices for short circuit or damage; 2. Check the setup (external supply max and external supply min); 3. Replace the failed devices.
0169	Power supply of FL motor controller exceeding the range		
0269	Power supply of FR motor controller exceeding the range		

Table 8-5 General fault codes of motor controller (Continued)

Fault code	Description	Cause	Solution
	controller exceeding the range		
0369	Power supply of RL motor controller exceeding the range		
0469	Power supply of RR motor controller exceeding the range		
0071	Operation software fault of pump motor controller	<ol style="list-style-type: none"> 1. Software problem; 2. Controller failure. 	<ol style="list-style-type: none"> 1. Update the software to the correct version; 2. Replace the controller.
0171	Operation software fault of FL motor controller		
0271	Operation software fault of FR motor controller		
0371	Operation software fault of RL motor controller		
0471	Operation software fault of RR motor controller		
0072	PDO timeout of pump motor controller	<ol style="list-style-type: none"> 1. Software problem; 2. CAN bus communication error. 	<ol style="list-style-type: none"> 1. Update the software to the correct version, and ensure the bus free of interference; 2. Ensure the bus terminal resistance is 60 ohm, the bus voltage approx. 2.5V; 3. Ensure the devices on the bus are correctly connected; 4. Check the on-bus devices are correctly programmed; 5. Use the exclusion method to replace the failed devices.
0172	PDO timeout of FL motor controller		
0272	PDO timeout of FR motor controller		
0372	PDO timeout of RL motor controller		
0472	PDO timeout of RR motor controller		
0073	Motor stalling of pump motor controller	<ol style="list-style-type: none"> 1. Motor stalling; 2. Encoder fault; 3. Improper wiring or motor damaged. 	<ol style="list-style-type: none"> 1. Check the power supply and wiring of motor encoder to ensure the speed signal can be properly delivered; 2. Ensure the brake is fully disengaged; 3. Check the motor and controller.
0173	Motor stalling of FL motor controller		
0273	Motor stalling of FR motor controller		
0373	Motor stalling of RL motor controller		
0473	Motor stalling of RR motor controller		
0077	System distress of pump motor controller	<ol style="list-style-type: none"> 1. The processor discovers illegal and redundant data; 2. The processor inside the controller fails; 3. The processor discovers the switching value 	<ol style="list-style-type: none"> 1. Check the internal micro-processor for damage; 2. Check input signals of all switches, and check the switches for wetting or damage.
0177	System distress of FL motor controller		
0277	System distress of FR motor controller		

Table 8-5 General fault codes of motor controller (Continued)

Fault code	Description	Cause	Solution
0377	System distress of RL motor controller	signal exceeds the threshold by 100ms (if the fault occurs repeatedly, please check if the switch gets wet or damaged).	
0477	System distress of RR motor controller		
0078	Incompatible system of pump motor controller	Incompatible operation system	Check the software for compatibility.
0178	Incompatible system of FL motor controller		
0278	Incompatible system of FR motor controller		
0378	Incompatible system of RL motor controller		
0478	Incompatible system of RR motor controller		
0082	Calibration error in pump motor controller	Internal controller fault	Check the internal controller for fault.
0182	Calibration error in FL motor controller		
0282	Calibration error in FR motor controller		
0382	Calibration error in RL motor controller		
0482	Calibration error in RR motor controller		
0083	Power supply fault of pump motor controller	<ol style="list-style-type: none"> 1. Internal voltage failure of controller; 2. Power supply failure of drive circuit. 	Check the internal controller for fault.
0183	Power supply fault of FL motor controller		
0283	Power supply fault of FR motor controller		
0383	Power supply fault of RL motor controller		
0483	Power supply fault of RR motor controller		
0087	Motor matching failure of pump motor controller	Description of motor matching failure codes: 0=Normal; 1=Encoder signal received, pseudo not identified, manual setup of the encoder pulse required; 2=Motor temp sensor failure; 3=Motor high-temp response failure; 4=Motor overheat	Check the encoder and motor for correct wiring.
0187	Motor matching failure of FL motor controller		
0287	Motor matching failure of FR motor controller		
0387	Motor matching failure of RL motor controller		
0487	Motor matching failure of RR motor controller		

Table 8-5 General fault codes of motor controller (Continued)

Fault code	Description	Cause	Solution
		response failure; 5=Motor low-temp response failure; 6=Low-volts response failure; 7=High-volts response failure; 8=Controller fails to detect the encoder signal; 9=Motor setup exceeding the range	
0088	Encoder pulse fault of pump motor controller	The encoder parameters do not match the actual motor encoder.	Check the encoder parameters.
0188	Encoder pulse fault of FL motor controller		
0288	Encoder pulse fault of FR motor controller		
0388	Encoder pulse fault of RL motor controller		
0488	Encoder pulse fault of RR motor controller		
0089	Motor type error of pump motor controller	Motor type data setup out of range	Modify the motor type data.
0189	Motor type error of FL motor controller		
0289	Motor type error of FR motor controller		
0389	Motor type error of RL motor controller		
0489	Motor type error of RR motor controller		
0091	VCL/OS mismatch of pump motor controller	Controller program error	Update the program to the correct version.
0191	VCL/OS mismatch of FL motor controller		
0291	VCL/OS mismatch of FR motor controller		
0391	VCL/OS mismatch of RL motor controller		
0491	VCL/OS mismatch of RR motor controller		
0092	Invalid solenoid brake setup of pump motor controller	<ol style="list-style-type: none"> 1. The machine moves freely after solenoid brake is triggered; 2. The holding force of solenoid brake is too weak. 	<ol style="list-style-type: none"> 1. Ensure the correct setup of solenoid brake and accelerator; 2. Check the brake disc of solenoid brake to determine whether it needs adjusting.
0192	Invalid solenoid brake setup of FL motor controller		
0292	Invalid solenoid brake setup of FR motor controller		

Table 8-5 General fault codes of motor controller (Continued)

Fault code	Description	Cause	Solution
0392	Invalid solenoid brake setup of RL motor controller		
0492	Invalid solenoid brake setup of RR motor controller		
0093	Restricted encoder operation of pump motor controller	<ol style="list-style-type: none"> 1. Motor stalling or encoder fault causes the restricted operational position of encoder to be activated; 2. Improper wiring; 3. Machine stalling. 	<ol style="list-style-type: none"> 1. Check the encoder power supply and ensure correct wiring; 2. Check the pulse count of encoder setup (programme/motor menu/encoder steps); 3. Check the encoder feedback speed signals (monitor/motor menu/motor speed A/B); 4. Replace the encoder.
0193	Restricted encoder operation of FL motor controller		
0293	Restricted encoder operation of FR motor controller		
0393	Restricted encoder operation of RL motor controller		
0493	Restricted encoder operation of RR motor controller		
0094	Emergency reverse response timeout of pump motor controller	<ol style="list-style-type: none"> 1. Emergency reverse switch always in closed position; 2. EmerTimer expires, which leads to the activation of emergency reverse timeout. 	<ol style="list-style-type: none"> 1. Use handhold unit to monitor emergency reverse (monitor /inputs menu/emerg Rev), if it keeps in the ON position, check the emergency reverse switch; 2. Check the wiring of emergency reverse switch; 3. Check the programming of emergency reverse.
0194	Emergency reverse response timeout of FL motor controller		
0294	Emergency reverse response timeout of FR motor controller		
0394	Emergency reverse response timeout of RL motor controller		
0494	Emergency reverse response timeout of RR motor controller		
0098	Model error of pump motor controller	<ol style="list-style-type: none"> 1. Controller model unidentifiable; 2. Controller software error; 3. Controller damaged. 	<ol style="list-style-type: none"> 1. Check the controller model; 2. Check the software version; 3. Replace the controller.
0198	Model error of FL motor controller		
0298	Model error of FR motor controller		
0398	Model error of RL motor controller		
0498	Model error of RR motor controller		
0099	2WD machine motor setup mismatch of pump motor controller	When the dual-motor is on, the control mode is not set as 0 or 1.	When the dual-motor is on, the control mode shall be set as 0 or 1. Check the parameter setting.

Table 8-5 General fault codes of motor controller (Continued)

Fault code	Description	Cause	Solution
0199	2WD machine motor setup mismatch of FL motor controller		
0299	2WD machine motor setup mismatch of FR motor controller		
0399	2WD machine motor setup mismatch of RL motor controller		
0499	2WD machine motor setup mismatch of RR motor controller		

Table 8-6 Special fault codes of motor controller

Fault code	Description	Cause	Solution
0052	CAN communication timeout of pump motor controller	Communication timeout 1s between motor controller and machine main controller	Check CAN3 signal lines between pump motor controller and machine main controller.
0053	Charging voltage overload of pump motor controller	Pump motor controller voltage 59V and timeout 3s	Check CAN3 signal lines between pump motor controller and machine main controller.
0152	CAN communication timeout of FL motor controller	Communication timeout 1s between FL motor controller and machine main controller.	Check CAN3 signal lines between FL motor controller and machine main controller.
0153	Communication timeout between FL and FR motor controllers	Communication timeout 1s between FL and FR motor controllers	Check CAN3 signal lines between FL and FR motor controllers.
0154	Communication timeout between FL and RL motor controllers	Communication timeout 1s between FL and RL motor controllers	Check CAN3 signal lines between FL and RL motor controllers.
0155	Communication timeout between FL and RR motor controllers	Communication timeout 1s between FL and RR motor controllers	Check CAN3 signal lines between FL and RR motor controllers.
0252	CAN communication timeout of FR motor controller	Communication timeout 1s between FR motor controller and machine main controller.	Check CAN3 signal lines between FR motor controller and machine main controller.
0257	Communication timeout between FR motor and main controller (FL)	FR motor controller timeout 1s to receive signal from FL motor controller	Check CAN3 signal lines between FR and FL motor controllers.
0352	CAN communication timeout of RL motor controller	Communication timeout 1s between RL motor controller and machine main controller.	Check CAN3 signal lines between RL motor controller and machine main controller.
0356	Communication timeout between RL motor and main	RL motor controller timeout 1s to receive signal from FL motor controller	Check CAN3 signal lines between RL and FL motor controllers.

Table 8-6 Special fault codes of motor controller (Continued)

Fault code	Description	Cause	Solution
	controller (FL)		
0452	CAN communication timeout of RR motor controller	Communication timeout 1s between RR motor controller and machine main controller.	Check CAN3 signal lines between RR motor controller and machine main controller.
0458	Communication timeout between RR motor and main controller (FL)	RR motor controller timeout 1s to receive signal from FL motor controller	Check CAN3 signal lines between RR and FL motor controllers.

Lithium Battery BMS Fault Codes

Table 8-7 Lithium battery BMS fault codes

Fault code	Description	Fault code	Description
0x101	Total Voltage Overvoltage-First Level	0x208	Discharge at High Temperature-Second Level
0x201	Total Voltage Overvoltage-Second Level	0x308	Discharge at High Temperature-Third Level
0x301	Total Voltage Overvoltage-Third Level	0x109	Charging at High Temperature-First Level
0x102	Total Voltage Undervoltage-First Level	0x209	Charging at High Temperature-Second Level
0x202	Total Voltage Undervoltage-Second Level	0x309	Charging at High Temperature-Third Level
0x302	Total Voltage Undervoltage-Third Level	0x10A	Large Temperature Difference-First Level
0x103	Battery Cell Overvoltage Threshold-First Level	0x20A	Large Temperature Difference-Second Level
0x203	Battery Cell Overvoltage Threshold-Second Level	0x30A	Large Temperature Difference-Third Level
0x303	Battery Cell Overvoltage Threshold-Third Level	0x10B	Charging Overcurrent Threshold-First Level
0x104	Battery Cell Undervoltage Threshold-First Level	0x20B	Charging Overcurrent Threshold-Second Level
0x204	Battery Cell Undervoltage Threshold-Second Level	0x30B	Charging Overcurrent Threshold-Third Level
0x304	Battery Cell Undervoltage Threshold-Third Level	0x10C	Discharge Overcurrent Threshold-First Level
0x105	Battery Cell Voltage Difference-First Level	0x20C	Discharge Overcurrent Threshold-Second Level
0x205	Battery Cell Voltage Difference-Second Level	0x30C	Discharge Overcurrent Threshold-Third Level
0x305	Battery Cell Voltage Difference-Third Level	0x10D	Low SOC-First Level
0x106	Discharge of Low Temperature-First Level	0x20D	Low SOC-Second Level

Table 8-7 Lithium battery BMS fault codes (Continued)

Fault code	Description	Fault code	Description
0x206	Discharge of Low Temperature-Second Level	0x30D	Low SOC-Third Level
0x306	Discharge of Low Temperature-Third Level	0x10E	High SOC-First Level
0x107	Charging at Low Temperature-First Level	0x20E	High SOC-Second Level
0x207	Charging at Low Temperature-Second Level	0x30E	High SOC-Third Level
0x307	Charging at Low Temperature-Third Level	0x20F	BMS Communication Fault-Second Level
0x108	Discharge at High Temperature-First Level	0x210	Abnormal Communication with Charger-Second Level

8.4 BASIC TROUBLE SHOOTING

Table 8-8 Table of faults and solutions

Fault	Cause	Solution
Power indicator not ON	Machine is not powered on.	The key switch is in the OFF position. The emergency stop button on the platform controller or the ground controller is pressed. The platform controller is malfunctioning or failure to power off the platform controller after downloading program. The ground controller is malfunctioning or failure to power off the ground controller after downloading program.
	CAN equipment offline	Inspect whether the leads of the power supply and communication are inserted properly and reliably. Inspect whether all pins of the Deutsch plugs for the platform controller and ground controller connecting cables are wired according to the drawing. Inspect whether the platform controller plug or the plug of the connecting cable between the platform controller and ground controller are in good contact. Inspect whether the platform controller is malfunctioning. Inspect whether the Deltatech plug of ground controller is firmly and correctly connected.
Tilt alarm always sounding while in level status	The level switch is not connected or has trouble.	Inspect whether the level switch is inserted properly and firmly. Inspect whether the level switch is malfunctioning.
Platform failed to be leveled	Electrical failure	Check the wiring and control program
	Function solenoid problem	Check the function solenoid, adjust the pressure or replace the function solenoid
	Cylinder or pipeline leakage	Check the pipeline and connectors for leakage. Check the cylinder or its seal for leakage.

Table 8-8 Table of faults and solutions (Continued)

Fault	Cause	Solution
Platform leveling with no response	Electrical failure	Check the wiring and control program
	Low hydraulic system oil level	Check the hydraulic oil level
	Function solenoid problem	Check the function solenoid, adjust the pressure or replace the function solenoid
	Oil lines blocked	Check the oil lines
	Slave cylinder failure	Repair or replace the cylinder
	Pump damaged	Replace the pump
Boom movement switches on platform controller with no response	The switch is not in correct position	The key switch is in OFF position. The ground controller is in ground control position. The emergency stop button on the ground controller or platform controller is pressed.
	Boom function switch not enabled with the foot switch depressed	Depress the foot switch again
	Boom function switch failure	Repair or replace the control switch, and perform system test
	Lift, luffing cylinder holding valve failure	Repair or replace the holding valve
	Bypass valve malfunctioning	Repair or replace the valve, check the wiring diagram or perform system test
	Low hydraulic system oil level	Check the hydraulic oil level
	Supply pipelines in valve housing or hydraulic pump restricted or damaged	Clean or replace the pipeline
	Directional valve malfunctioning	Repair or replace the valve
	Lift, luffing cylinder failure	Repair or replace the cylinder
Boom movement switches on ground controller with no response	The switch is not in correct position	The key switch is in OFF position. The ground controller is in platform control position. The emergency stop button on the ground controller or platform controller is pressed.
	Boom function switch failure	Repair or replace the control switch, and perform system test
	Lift, luffing cylinder holding valve failure	Repair or replace the holding valve
	Bypass valve malfunctioning	Repair or replace the valve, check the wiring diagram or perform system test
	Low hydraulic system oil level	Check the hydraulic oil level
	Supply pipelines in valve housing or hydraulic pump restricted or damaged	Clean or replace the pipeline
	Directional valve malfunctioning	Repair or replace the valve

Table 8-8 Table of faults and solutions (Continued)

Fault	Cause	Solution
	Lift, luffing cylinder failure	Repair or replace the cylinder
Turntable failed to rotate to certain direction	Hydraulic pipeline or connector blocked	Clean, repair or replace the pipeline or connector
	Directional valve malfunctioning	Clean, repair or replace the directional valve
	Rotation control handle malfunctioning	Clean, repair or replace the rotation control handle
Turntable rotating to the left/right abnormally	Low hydraulic system oil level	Check the hydraulic oil level
	Insufficient lubrication for slewing bearing	Lubricate the bearing as needed
	Slewing motor functioning abnormally	Repair or replace the slewing motor
	Slewing bearing excessively worn	Slewing bearing
	Throttle valve blocked	Clean or replace the throttle valve
Chassis failed to steer	Function solenoid failure or low steer pressure	Check the function solenoid and adjust the pressure
	Cylinder failure	Clean, repair or replace the cylinder
	Low hydraulic system oil level	Check the hydraulic oil level
	Pump with no pressure oil output	Check the pump for damage
Travel control with no response	The switch is not in correct position	The key switch is in OFF position. The ground controller is in ground control position. The emergency stop button on the ground controller or platform controller is pressed.
	Electrical failure	Check the wiring and control program
	Travel motor damaged	Replace the travel motor
	Pump damaged	Replace the pump
	Motor controller damaged.	Replace the motor controller.
	Invalid brake release valve	Check the valve for blocking and leakage.
	Insufficient brake release pressure	Adjust the brake release pressure
Forward function failed while with no warning	Forward traveling function is malfunctioning.	Check whether the PWM plug of the ground controller is inserted correctly and securely. Check whether the connection of the forward valve is normal. Inspect whether the ground controller is malfunctioning.
Backward function failed while with no warning	Backward traveling function is malfunctioning.	Check whether the PWM plug of the ground controller is inserted correctly and securely. Check whether the connection of the forward valve is normal. Inspect whether the ground controller is malfunctioning.

Table 8-8 Table of faults and solutions (Continued)

Fault	Cause	Solution
Tilt warning	The level switch is abnormal	The level switch air bubble is not in the middle position. The level switch is not connected properly or firmly. The ground controller is malfunctioning.
No overload warning	Weight sensor not calibrated for rated load or calibrated with wrong lift height	The sensor is not calibrated. The wiring of the load sensor is incorrect. The sensor is malfunctioning.
Machine travels and then stops intermittently	The battery level is low/the calibration is incorrect	Re-calibrate the parameters. The battery is out of power, not as indicated by the battery gauge.
Parameters after setting could not be saved successfully after several attempts	Abnormal storage	The parameters exceed the limit. Ground controller malfunctioning.

8.5 ELECTRICAL SYMBOLS

Table 8-9

Symbol	Description
	Buzzer
	Valve
	Two lines connected
	Motor

Table 8-9 (Continued)

Symbol	Description
	Storage battery
	Lithium battery
	Toggle switch
	Level switch

Table 8-9 (Continued)





Symbol	Description
	Oil temperature switch
	Delay relay
	Main power switch
	Relay
	Warning light
	Valve
	Two lines not connected

Table 8-9 (Continued)

Symbol	Description
	Proximity switch/ Pressure sensor
	Fuel level sensor
	Horn
	Key switch
	Preheating wire

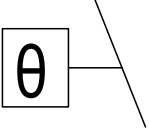
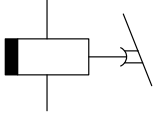
8.6 ELECTRICAL SCHEMATIC DIAGRAM

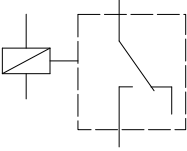
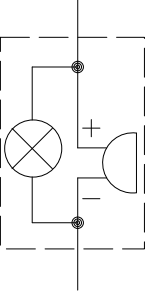
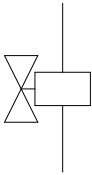
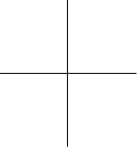
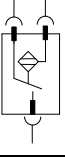
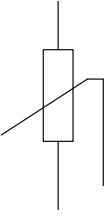
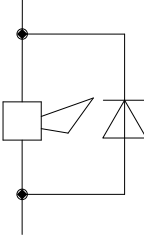
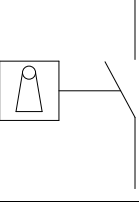
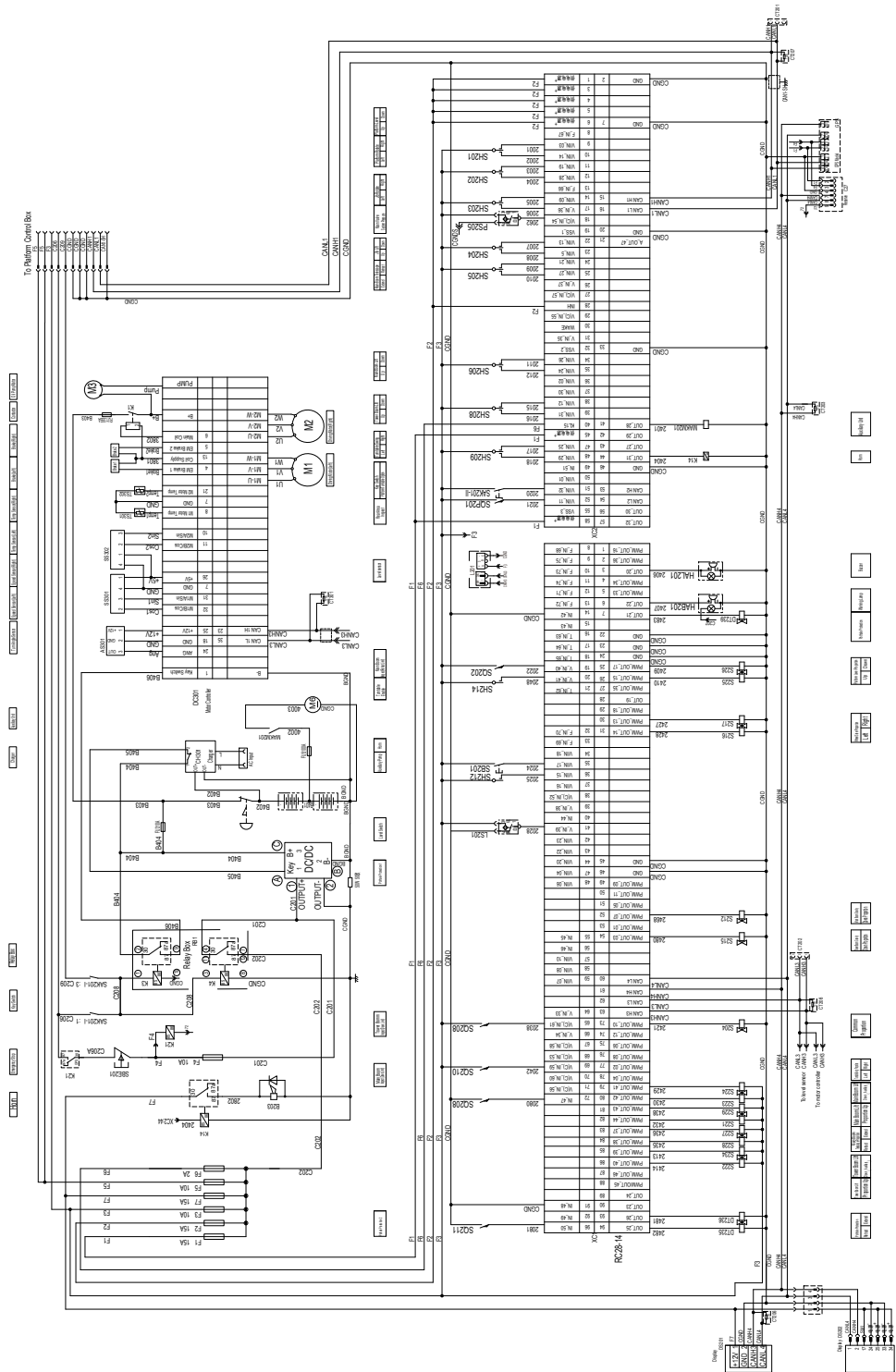

Fig 1 Electrical Schematic Diagram of Turntable

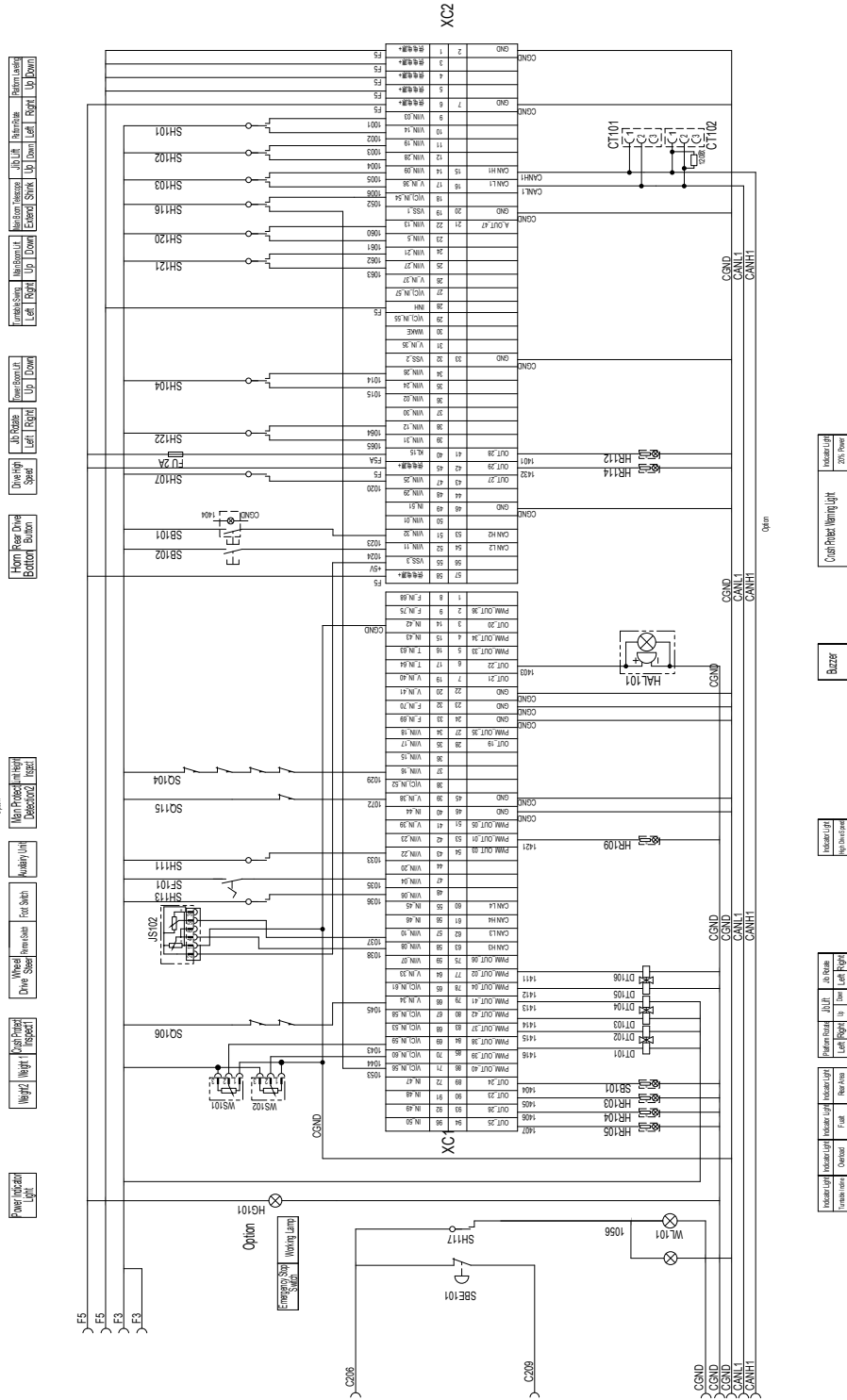

Fig 2 Electrical Schematic Diagram of Platform

This Page Intentionally Left Blank

9 FUNCTIONS AND CONTROLS

9.1 DRIVE FUNCTION

Driving at reasonable speed is essential for ensuring machine safety. The drive function should respond quickly and smoothly under the control of the operator. The machine should travel without shaking, shocks and abnormal noise over the controllable speed range. To ensure that the drive unit runs smoothly and keeps good condition, it is recommended to check the drive function every 3 months or after 250 hours of operation.

Select flat, level, unobstructed and solid ground to perform the following tests with the platform carrying one person and stowed:

1. Mark two straight lines with the distance of 30m (98.4ft) on the ground as the test start and stop lines.
2. Start the machine.
3. Depress the foot switch.
4. Slowly push the travel/steer control handle forward to the full drive position.
5. Move the high/low engine speed selector switch on the platform controller to switch the engine speed to high speed (if the machine is equipped with an engine).
6. Push the high/low travel speed selector switch on the platform controller upwards to switch the travel speed to high speed.
7. When the front wheel contacts with the test start line, press the timer to start timing.
8. Keep the machine running at high speed until the contact point between the front wheel and the ground reaches the test stop line, and stop timing.
9. Calculate the travel speed with the measured data and compare it with the specified maximum travel speed in the stowed position.

NOTICE

If the above calculation result exceeds the maximum travel speed in the stowed position by 10%, immediately lower the platform to the stowed position, turn off and mark the machine, and contact a qualified service technician for inspection and repair.

9.2 BRAKING FUNCTION

Proper braking function is essential for the safe operation of the machine. The braking device should respond quickly and smoothly without any abnormal noise under the control of the operator. To ensure that the brake device works smoothly and keep good condition, it is recommended to check the brake device every 3 months or after 250 hours of operation.

The braking distance of the machine controlled within the normal range is an important indicator of the normal braking function of the machine. Select flat, level, unobstructed and solid ground to perform the following tests with the platform carrying one person and stowed:

1. Check to make sure the drive hub cap is engaged.
2. Mark a test line on the ground as a reference.
3. Start the machine.
4. Depress the foot switch.
5. Slowly push the travel/steer control handle forward to the full drive position.
6. Move the high/low engine speed selector switch on the platform controller to switch the engine speed to high speed (if the machine is equipped with an engine).
7. Push the high/low travel speed selector switch on the platform controller upwards to switch the travel speed to high speed.
8. When the front wheel contacts with the test line, quickly release the travel/steer control handle.
9. Measure the vertical distance between the test line and the contact point between the front wheel and the ground, which is the braking distance.
10. Compare the measured distance with specified braking distance at full travel speed.

NOTICE

If the measured distance exceeds the specified maximum braking distance, immediately lower the platform to the stowed position, turn off and mark the machine, and contact a qualified service technician for inspection and repair.

9.3 POTHOLE PROTECTION DEVICE

Function of pothole protection device: when the platform rises to a certain height, the pothole protection device will be extended to the vertical position and get close to the ground, and rested on the ground to prevent the machine from tipping when the machine is driven into a pothole. It is recommended to check the pothole protection device every 3 months or after 250 hours of work.

Select flat, level, unobstructed and solid ground to perform the following tests:

1. Start the machine.
2. When raising the platform from the stowed position to the operating position, the pothole protection devices on the left and right sides of the chassis should be fully extended to be perpendicular to the ground.
3. Push the pothole protection device hard which should not be flipped.
4. When the platform is lowered to the non-operating position, the pothole protection device will be retracted.
5. Place a 50mm (2in)-high wooden block under the pothole protection device on the left side of the chassis.
6. Raise the platform to the operating position, the buzzer will sound, and the display will show the pothole protection fault code, with the platform lift and traveling/steering functions disabled.
7. Lower the platform to the stowed position and remove the wooden block under the pothole protection device on the left side of the chassis.
8. Perform the same test from step 5 on the pothole protection device on the right side of the chassis.

NOTICE

If the pothole protection device is found to be ineffective during the test, please immediately lower the platform to the stowed position, turn off and mark the machine, and contact a qualified service technician for inspection and repair.

9.4 TILT PROTECTION FUNCTION

The proper functioning of the tilt sensing system is essential for the safe operation of the machine. It is recommended to check the tilt sensing system every 3 months or after 250 hours of operation.

Select flat, level, unobstructed and solid ground to perform the following tests:

In the non-operating position:

1. Start the machine.
2. Push the level switch in the X (left-right)/Y (front-rear) direction by more than 3°. Then, the tilt alarm should be triggered, the chassis tilt indicator should flash, and no actions will be restricted.
3. Place two wooden blocks with the dimensions shown in the table below before the two wheels on the left (or right) side of the machine and drive the machine onto these two blocks. Then, the tilt alarm should be triggered, the chassis tilt indicator should flash, and no actions will be restricted.
4. Drive the machine off the wooden blocks and remove the wooden blocks.
5. Place two wooden blocks with the dimensions shown in the table below before the two front (or rear) wheels of the machine and drive the machine onto these two blocks. Then, the tilt alarm should be triggered, the chassis tilt indicator should flash, and no actions will be restricted.
6. Drive the machine off the wooden blocks and remove the wooden blocks.

In the operating position:

1. Start the machine.
2. Push the level switch in the X (left-right)/Y (front-rear) direction by more than 3°. Then, the tilt alarm should be triggered, the chassis tilt indicator should flash, and certain actions will be restricted. The main boom can be retracted, the articulated boom can be lowered, the turntable can rotate slowly, and the main boom can be lowered after fully retracted.
3. Place two wooden blocks with the dimensions shown in the table below before the two wheels on the left (or right) side of the machine and drive the machine onto these two blocks. Then, the tilt alarm should be triggered, the chassis tilt indicator should flash, and certain actions will be restricted. The main boom can be retracted, the articulated boom can be lowered, the turntable can rotate slowly, and the main boom can be lowered after fully retracted.
4. Adjust the boom tube to the non-operating position, drive the machine off the wooden blocks and remove the wooden blocks.
5. Place two wooden blocks with the dimensions shown in the table below before the two front (or rear) wheels of the machine and drive the machine onto these two blocks. Then, the tilt alarm should be triggered, the chassis tilt indicator should flash, and certain actions will be restricted. The main boom can be retracted, the articulated boom can be lowered, the turntable can rotate slowly, and the main boom can be lowered after fully retracted.
6. Adjust the boom tube to the non-operating position, drive the machine off the wooden blocks and

remove the wooden blocks.

NOTICE

If the machine operation cannot be accurately

restricted during the test, please immediately lower the platform to the stowed position, turn off and mark the machine, and contact a qualified service technician for inspection and repair.

Table 9-1 Wooden block dimension

Wooden block position	Length	Width	Height
Left (or right) wheel	750mm (2.46ft)	250mm (0.82ft)	63mm (0.21ft)
Front (or rear) wheel	750mm (2.46ft)	250mm (0.82ft)	87mm (0.29ft)

9.5 MAXIMUM WORKING ENVELOPE LIMIT FUNCTION

The machine system can detect the position of the boom by means of the travel switch mounted on the boom tube. When the system detects the boom in the limit position, the boom movement will be restricted.

The maximum working envelope limit function is essential for the safe operation of the machine, which, if failed, may affect the stability of the machine. It is recommended to check the maximum working envelope limit function every 3 months or after 250 hours of operation.

NOTICE

If the machine operation cannot be accurately restricted during the test, please immediately lower the platform to the stowed position, turn off and mark the machine, and contact a qualified service technician for inspection and repair.

Horizontal Reach Restriction

A travel switch is used to detect the boom position and limit the boom from further extending when the boom length exceeds the maximum horizontal reach.

1. Start the machine from the turntable controller.
2. Move the articulated boom luffing switch to fully retract the articulated boom.
3. Move the main boom luffing switch and the jib boom luffing switch (if any) to adjust the main boom and jib arm (if any) horizontal.
4. Move the main boom telescope switch to extend the main boom.
5. When the main boom extends to the farthest position, the main boom cannot continue to extend nor be lifted/lowered but can be retracted, and the turntable can slowly rotate. Then measure the

horizontal reach, which should be 6.3m (20ft 8in) (distance from the center of the slewing bearing to the outermost side of the platform).

6. Move the main boom telescope switch to fully retract the main boom.

9.6 OVERLOAD LIMIT FUNCTION

The rated load capacity of the platform is clearly specified in the **Machine Specifications** section of this manual, and if the platform is overloaded, the machine operation should be limited.

The proper functioning of the overload limit system is essential for the safe operation of the machine, because its malfunction may affect the stability of the machine. It is recommended to check the overload limit function every 3 months or after 250 hours of operation.

Select flat, level, unobstructed and solid ground to perform the following tests with the platform unloaded:

1. Start the machine.
2. Fully raise and lower the boom and retract and extend the boom twice separately to ensure that the machine has no obvious shaking and abnormalities, and is properly lubricated.
3. After lowering the platform to the stowed position, gradually apply load to the platform according to the rated load capacity of the platform.

NOTICE

If the machine operation cannot be accurately restricted during the test, please immediately lower the platform to the stowed position, turn off and mark the machine, and contact a qualified service technician for inspection and repair.

The test results should be as follows if the overload limit system works normally:

Table 9-2

Mode	Test results
KG mode	When the load on the platform exceeds 230kg (507lb), the buzzer will sound, the overload indicator light will flash, the display will indicate overload, and all functions will be disabled. After the excess load is removed, all functions will be resumed.
Non-KG mode	When the load on the platform exceeds 230kg (507lb), the buzzer will sound, the overload indicator light will flash, the display will indicate overload, and certain functions will be disabled. But the main boom can be retracted, the articulated boom can be lowered, the turntable can rotate slowly, and the main boom can be lowered after fully retracted. After the excess load is removed, all functions will be resumed.

10 CONTROL SYSTEM

DANGER

All operations in this section must be performed by qualified personnel who have been professionally trained and authorized by Sinoboom, otherwise the consequences will be at your own risk.

WARNING

Unsafe Operation Hazard



- The machine has been commissioned before delivery. It's forbidden to modify the system settings and update the program without authorization from Sinoboom.

Due to different machine configurations, certain descriptions below may be inapplicable to your machine. In case of any operational questions when operating the machine as per the manual, please stop operation and contact Sinoboom after-sales personnel in time.

- Incorrect operation may result in death, serious injury or machine damage.

NOTICE

PCU, ECU, sensors, etc. are precisely adjusted and protectively treated before delivery. Therefore, personnel who have not been professionally trained and authorized by Sinoboom cannot disassemble their housings, otherwise moisture and dust will enter the internal mechanism and normal operation will not be guaranteed.

This section is applicable to Rexroth control system equipped with the Rising display.

10.1 DISPLAY INTERFACE

The system interface is as shown in the figure below:

Note: some interfaces can only be accessed with a password (the password can only be provided to personnel professionally trained and authorized by Sinoboom).

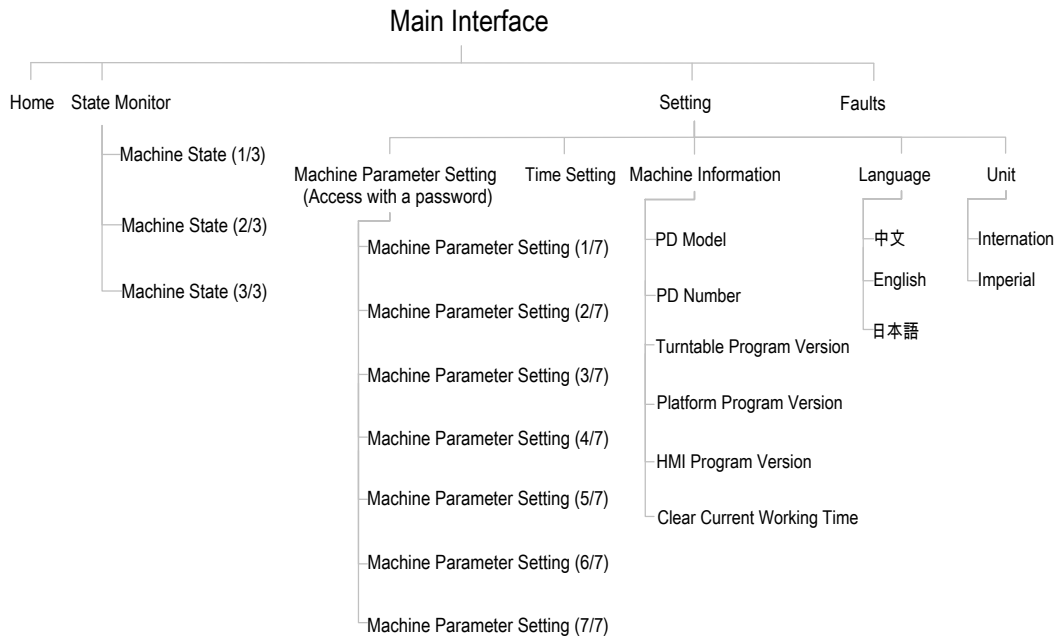

Fig 1 Display interface navigation

10.2 HOME INTERFACE AFTER BOOTING

Turn the ground/platform selector switch on the ground controller to the ground control position, pull out the emergency stop button to the ON position, the system will be powered on.

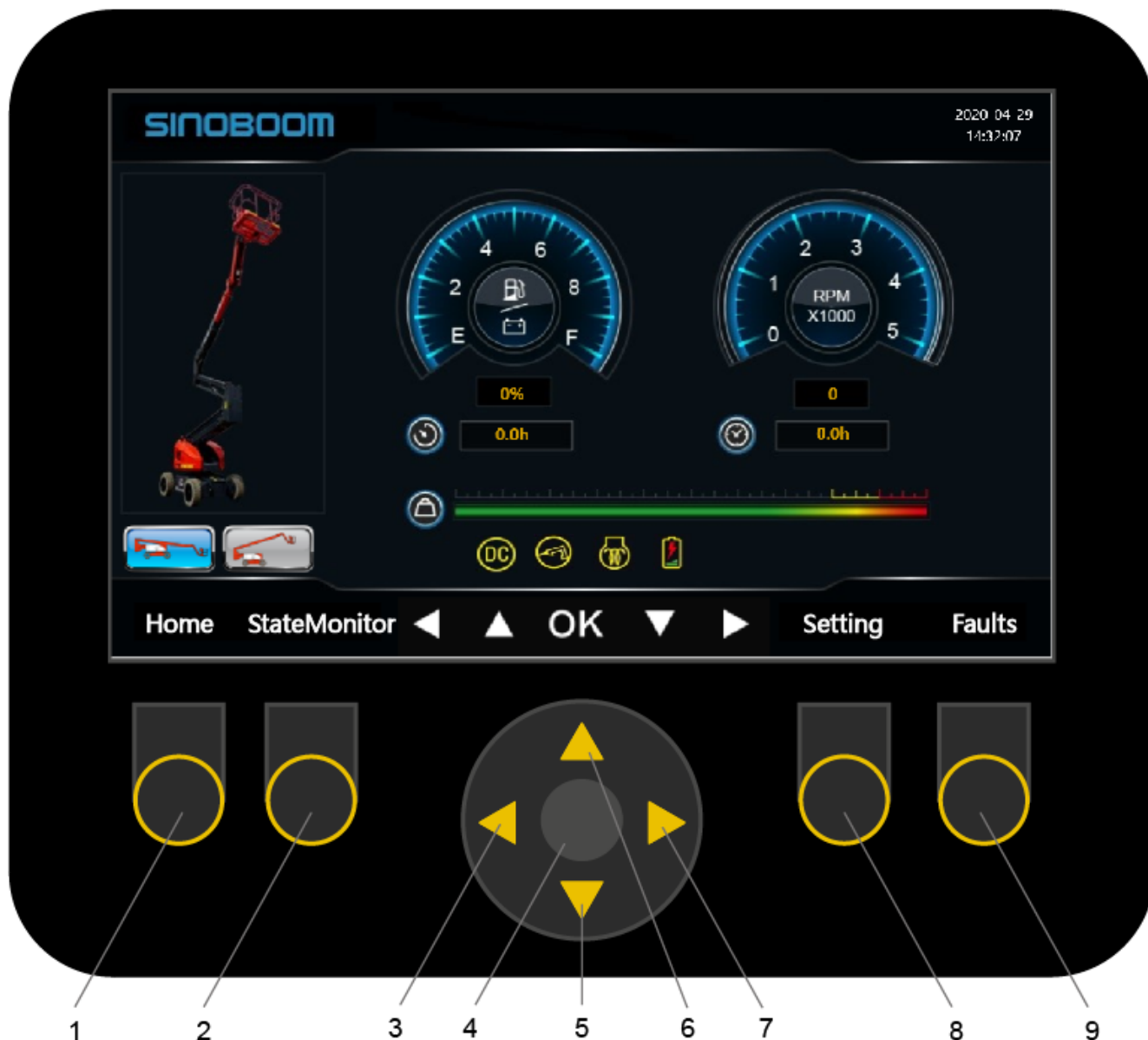

Fig 2 Home interface after booting

Table 10-1

1. Home	4. OK button	7. Right shift key/next page
2. State monitor/next page	5. Down shift key	8. Setting
3. Left shift key	6. Up shift key	9. Faults

10.3 STATE MONITOR

1. On the Home interface, press the State Monitor button to enter the Machine State (1/3) interface.

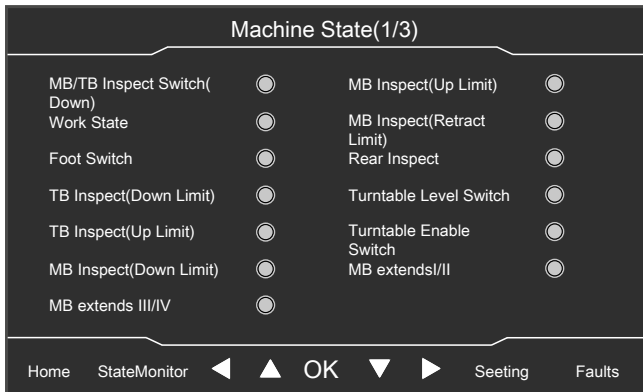



Fig 3 Machine State (1/3) interface

- The Machine State (1/3) interface is mainly used to query the signal detection status of the detection switches (such as travel switches and proximity switches) configured on the machine, to determine whether the detection switches are working normally and whether the working status of the machine meets the requirements. When the indicator light corresponding to the option lights up , it means that the switch has detected a signal; when the indicator light is off, it means that the switch has not detected a signal.
 - The configuration of switches is subject to the actual machine configurations.
- On the Machine State (1/3) interface, press the right shift key to enter the Machine State (2/3) interface.

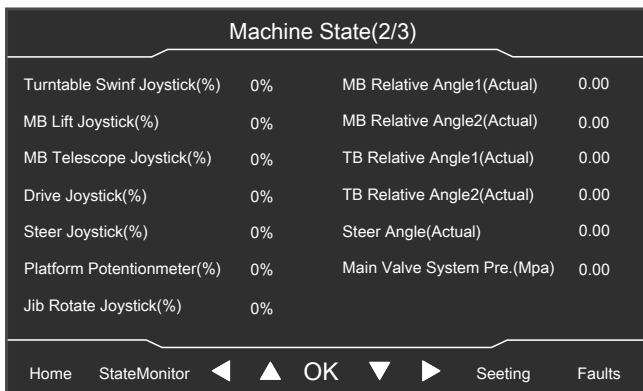

Fig 4 Machine state (2/3) interface

- This interface is mainly used to query the current actual value of each joystick/potentiometer and the actual value of the sensors configured on the machine, to check whether the position status of each joystick/potentiometer is normal, and to determine whether each sensor is working normally.
- The configuration of switches is subject to the actual machine configurations.

- On the Machine State (2/3) interface, press the right shift key to enter the Machine State (3/3) interface.

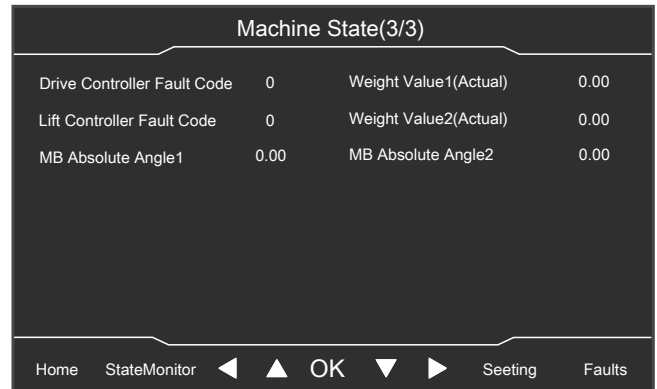

Fig 5 Machine state (3/3) interface

- This interface is mainly used to query the current fault codes of each motor controller and the actual value of the sensors configured on the machine, to check whether the status of each motor controller is normal, and to determine whether each sensor is working normally.
- Press the Home button to return to the Home interface, and power off the machine as needed.

10.4 FAULT INQUIRY

- On the Home interface, press the Faults button to enter the “Current Faults (1/1)” interface, which is mainly used to query the current faults of the machine. For detailed fault descriptions, see the **Fault Code Description** section in the Maintenance Manual.

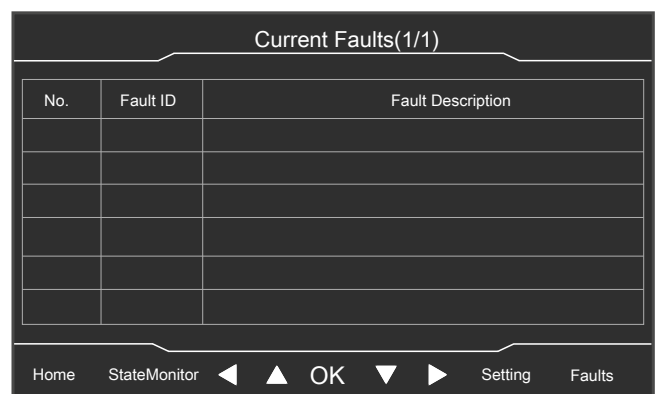

Fig 6 Current Faults (1/1) interface

- Press the Home button to return to the Home interface, and power off the machine as needed.

10.5 SETTING

DANGER

Personnel who have not been professionally trained and authorized by Sinoboom are not allowed to modify the options in parameter setting (including joystick calibration, sensor calibration, standardization setting, overload limit setting, travel limit setting, interlock unlocking and position parameter setting); otherwise they will be responsible for the consequences.

On the Home interface, press the Setting button to enter the System Setting interface.

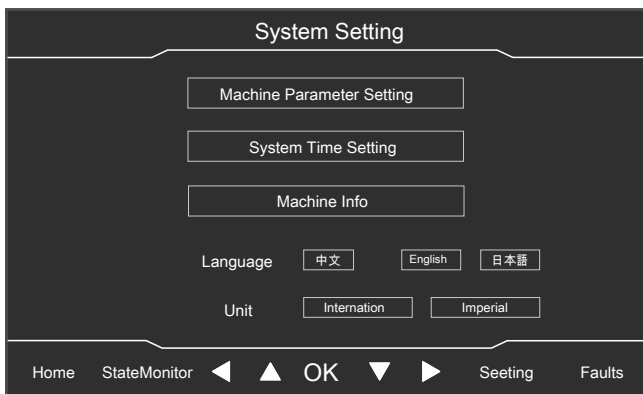

Fig 7 System Setting interface

Machine Parameter Setting

1. On the System Setting interface, select Machine Parameter Setting by pressing the up shift key and down shift key, and press OK button to enter Machine Parameter Setting (1/7) interface.

Note: A password is required to enter this interface. Use the left shift key and right shift key to change the selected item, and use the up shift key and down shift key to adjust the value of the selected item.

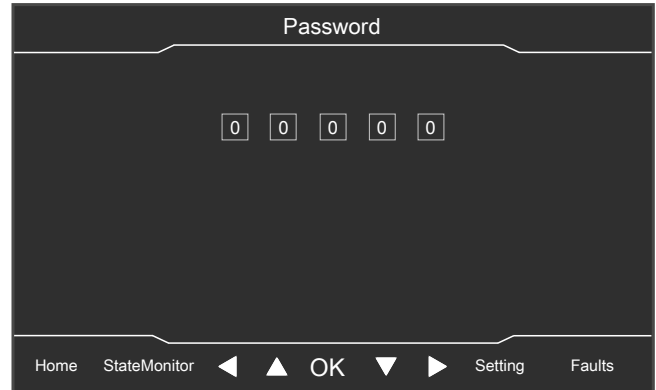

Fig 8 Password interface

2. The Machine Parameter Setting (1/7) interface is mainly used for joystick calibration.

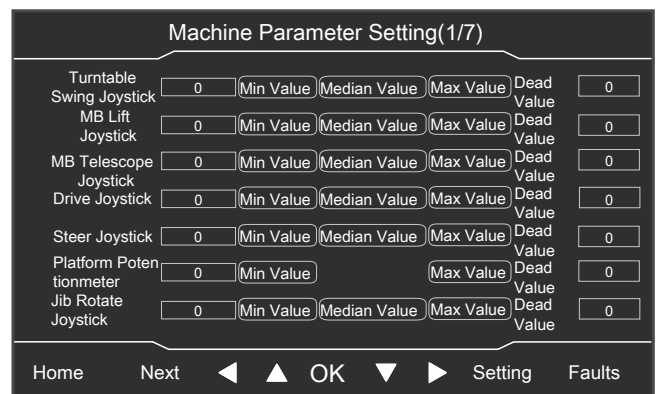

Fig 9 Machine Parameter Setting (1/7) interface

- 1) Select the calibration item by pressing the up shift key, down shift key, left shift key and right shift key, push the joystick to the corresponding position, and press and hold the OK button for 3 seconds to save and complete the calibration.
 - 2) If the parameters of the item need to be re-calibrated, press the Setting button to return to the System Setting interface, then re-enter the Machine Parameter Setting (1/7) interface, and repeat the previous steps.
 - 3) Press the Home button to return to the Home interface, and power off the machine as needed.
3. On the Machine Parameter Setting (1/7) interface, press the Next button to enter the Machine Parameter Setting (2/7) interface, which is mainly used for sensor calibration.

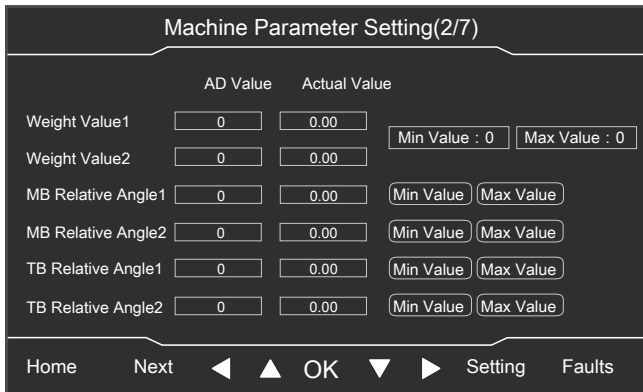

Fig 10 Machine Parameter Setting (2/7) interface

- **Weight calibration**

NOTICE

If the machine is equipped with a dual-channel sensor, when pressing and holding OK button for 3s for no-load and heavy-load calibration, the two channels will be calibrated at the same time.

- 1) Make sure that no heavy objects are placed on the platform and that the platform is stable without shaking.
- 2) Enter the Machine Parameter Setting (2/7) interface, select the “Min Value” by pressing the up shift key, down shift key, left shift key and right shift key, adjust the value to 0 by pressing the up shift key and down shift key, press and hold the OK button for 3 seconds to complete the no-load calibration.
- 3) Place a heavy object with the weight equal to the rated load of the machine on the platform, and ensure that the platform is stable without shaking.
- 4) Select the “Max Value” by pressing the left shift key and right shift key, adjust the value to the weight value of the heavy object on the platform by pressing the up shift key and down shift key, press and hold the OK button for 3 seconds to complete the full-load calibration (the actual weight value on left side of the display screen is equal to the weight value of loads on the platform).
- 5) If re-calibration is required, press the Setting button to return to the System Setting interface, then re-enter the Machine Parameter Setting (2/7) interface, and repeat the previous steps.
- 6) Press the Home button to return to the Home interface, and power off the machine as needed.

- **Sensor calibration**

NOTICE

If the machine is equipped with a dual-channel sensor, only 1 channel is needed to be selected for maximum value and minimum value calibration.

- 1) Enter the Machine Parameter Setting (2/7) interface, select the position to be calibrated by pressing the up shift key, down shift key, left shift key and right shift key, press and hold the OK button for 3 seconds to complete the calibration (after successful calibration, the actual value will be changed).
- 2) If re-calibration is required, press the Setting button to return to the System Setting interface, then re-enter the Machine Parameter Setting (2/7) interface, and repeat the previous steps.
- 3) Press the Home button to return to the Home interface, and power off the machine as needed.
4. On the Machine Parameter Setting (2/7) interface, press the Next button to enter the Machine Parameter Setting (3/7) interface, which is mainly used for sensor calibration. Perform calibration referring to the above steps.

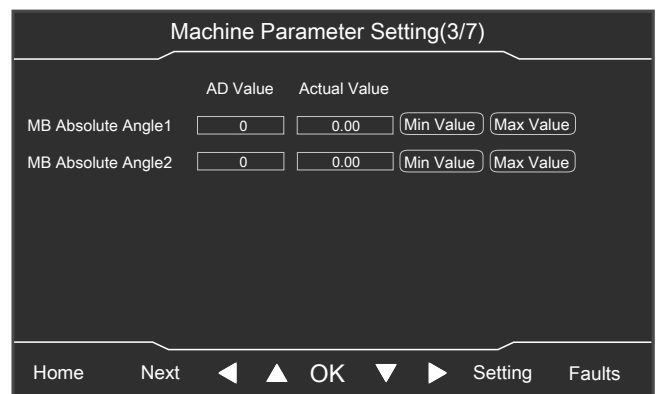

Fig 11 Machine Parameter Setting (3/7) interface

5. On the Machine Parameter Setting (3/7) interface, press the Next button to enter Machine Parameter Setting (4/7) interface.

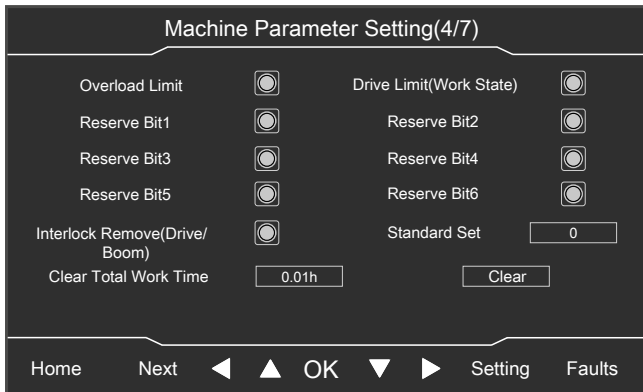

















Fig 12 Machine Parameter Setting (4/7) interface

- 1) On the interface, select the required standard or function by pressing the up shift key, down shift key, left shift key and right shift key.
- 2) **Overload limit setting:** Select the Overload Limit option, and press and hold the OK button for 3s to confirm the setting. The corresponding indicator light will light up  after successful setting, and the KG icon () will be displayed in the upper right corner of the Home interface.
- 3) **Drive Limit (Work State) setting:** Select the Drive Limit (Work State) option, and press and hold the OK button for 3s to confirm the setting. The corresponding indicator light will light up  after successful setting, and the DR icon () will be displayed in the upper right corner of the Home interface.
- 4) **Interlock Remove (Drive/Boom) setting:** Select the Interlock Remove (Drive/Boom) option, and press and hold the OK button for 3s to confirm the setting. The corresponding indicator light will light up  after successful setting, and the D/B icon () will be displayed in the upper right corner of the Home interface.
- 5) **Standard setting:** Select the Standard Set option, change the value by pressing the up shift key and down shift key, and press and hold the OK button for 3s to confirm the setting. The corresponding indicator light will light up  after successful setting.
 - After changing the value to “0” and confirming the setting, the program will not implement any standard restrictions.
 - After changing the value to “1” and confirming the setting, the program will implement the restrictions of CE standard, and the icon of CE standard () will be displayed in the upper right corner of the Home interface.
 - After changing the value to “2” and

confirming the setting, the program will implement the restrictions of ANSI standard, and the icon of ANSI standard () will be displayed in the upper right corner of the Home interface.

- After changing the value to “3” and confirming the setting, the program will implement the restrictions of CSA standard, and the icon of CSA standard () will be displayed in the upper right corner of the Home interface.
 - After changing the value to “4” and confirming the setting, the program will implement the restrictions of AS standard, and the icon of AS standard () will be displayed in the upper right corner of the Home interface.
 - After changing the value to “5” and confirming the setting, the program will implement the restrictions of KCS standard, and the icon of KCS standard () will be displayed in the upper right corner of the Home interface.
 - After changing the value to “6” and confirming the setting, the program will implement the restrictions of JIS standard, and the icon of JIS standard () will be displayed in the upper right corner of the main interface.
 - After changing the value to “7” and confirming the setting, the program will implement the restrictions of EAC standard, and the icon of EAC standard () will be displayed in the upper right corner of the Home interface.
 - After changing the value to “8” and confirming the setting, the program will implement the restrictions of UKC standard, and the icon of UKC standard () will be displayed in the upper right corner of the Home interface.
- 6) **Reserve Bit setting:** the reserve bit is reserved for later use. Select the Reserve Bit option, and press and hold the OK button for 3s to confirm the setting. The corresponding indicator light will light up  after successful setting.
 - 7) **Clear Total Work Time setting:** Select the Clear option, and press and hold the OK button for 3s to complete the clearing. The total work time can only be cleared once (after clearing, the total work time will be about 36.5h), so please use the function with caution.
 - 8) If re-selection is required, press the Setting button to return to the System Setting interface, then enter the Machine Parameter Setting (4/7) interface again and repeat the previous steps to select the required option.

- 9) Press the Home button to return to the Home interface, and power off the machine as needed.

Note:

- Under the KG mode, all movements of the machine in operating position will be restricted when the platform is overloaded. For the differences between the KG mode and non-KG mode, refer to the **Test Weighing System** section in the maintenance procedures of this manual.
 - Under the DR mode, the drive function will be restricted when the machine is in operating position.
 - Under the D/B mode, the drive function and boom movement can be performed at the same time.
6. On the Machine Parameter Setting (4/7) interface, press the Next button to enter Machine Parameter Setting (5/7) interface.

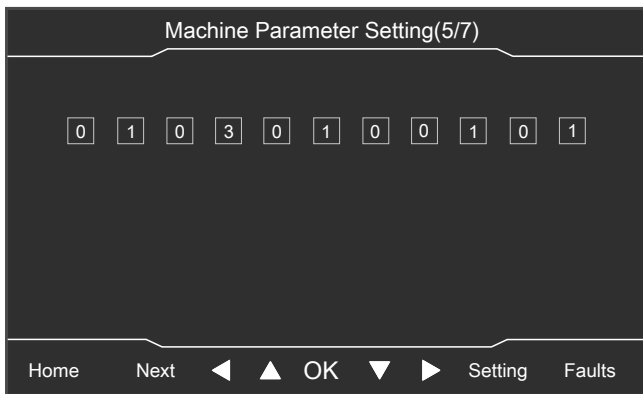

Fig 13 Machine Parameter Setting (5/7) interface

- 1) On the interface, the machine serial number can be set. Change the selected option by pressing the left shift key and right shift key, and adjust the value by pressing the up shift key and down shift key, press the OK button to confirm and save the setting.
 - 2) If re-setting is required, press the Setting button to return to the System Setting interface, then enter the Machine Parameter Setting (4/7) again and repeat the previous steps.
 - 3) Press the Home button to return to the Home interface, and power off the machine as needed.
7. On the Machine Parameter Setting (6/7) interface, press the Next button to enter Machine Parameter Setting (7/7) interface. On the interface, select the “Restore Total Hour” option, then press the OK button, and 6 minutes later, the total work time of the machine can be restored.

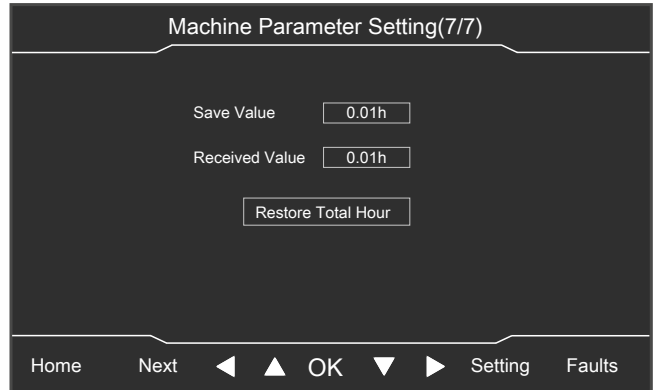

Fig 14 Machine Parameter Setting (7/7) interface

Note:

- The controller collects the working time of the machine and sends data to the display screen every 6 minutes. The Received Value is the data received by the display screen; the Save Value is the data saved by the display screen. The Received Value and Save Value are the same normally.
- If a new controller is installed after the machine operates for a period of time, the Received Value will be 0, and the Save Value is the total working hour of the machine. Select the “Restore Total Hour” option, then press the OK button, and 6 minutes later, the Received Value can be restored to the total working hour of the machine.

Time Setting

1. On the System Setting interface, select Time Setting by pressing the up shift key and down shift key, and press the OK button to enter Time Setting interface.

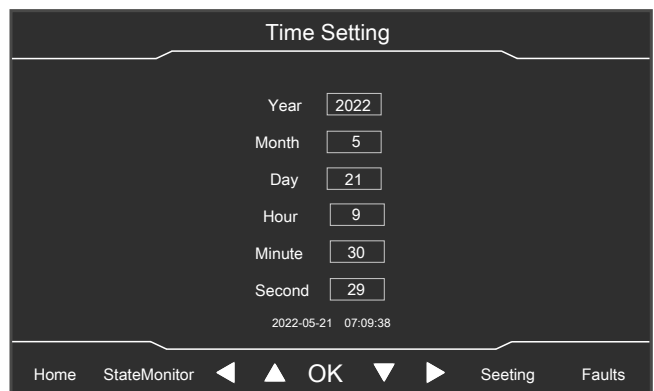

Fig 15 Time Setting interface

2. On the interface, change the selected item by pressing the left shift key and right shift key, adjust the value by pressing the up shift key and down shift key, and press the OK button to confirm and save

the setting.

3. If resetting is required, press the Setting button to return to the System Setting interface, then enter Time Setting interface, and repeat the above steps.
4. Press the Home button to return to the Home interface, and power off the machine as needed.

Machine Information

1. On the System Setting interface, select the “Machine Info” by pressing the up shift key and down shift key, and press the OK button to enter the Machine Information interface.

Fig 16 Machine Information interface

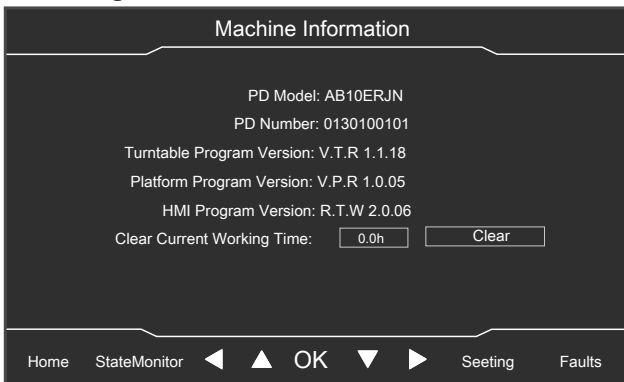

2. This interface is mainly used to query the detailed information of the current software program version of the machine and to clear the current working time.
3. Select the “Clear” option, press and hold the OK button for 3 seconds to complete the clearing of current working time.
4. Press the Home button to return to the Home interface, and power off the machine as needed.

Language Setting

1. On the Home interface, press the Setting button to enter the System Setting interface.

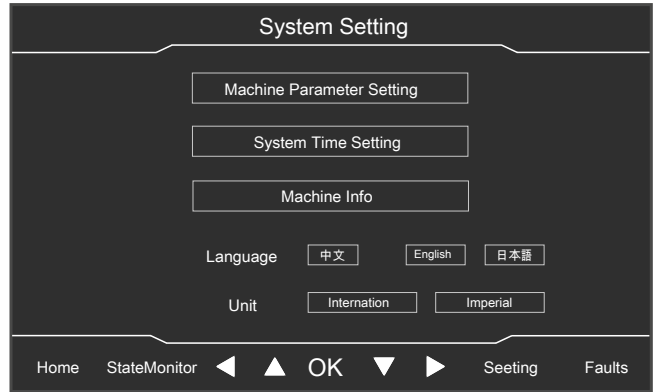

Fig 17 System Setting interface

2. Change the selected item by pressing the up shift key, down shift key, left shift key and right shift key, and press the OK button to complete language setting.

Unit Setting

1. On the Home interface, press the Setting button to enter the System Setting interface.

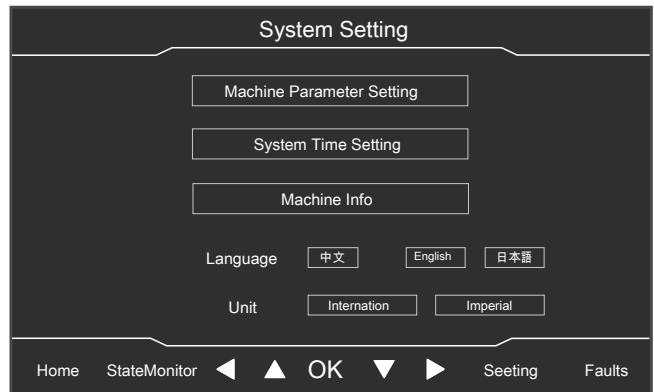

Fig 18 System Setting interface

2. Change the selected item by pressing the up shift key, down shift key, left shift key and right shift key, and press the OK button to complete unit setting.

This Page Intentionally Left Blank

11 OPTIONS

11.1 SECONDARY GUARDING

Self-propelled boom-supported elevating work platforms are designed to transport people, tools and materials to aerial workplaces. When the operator stands on the platform to operate the machine with the back facing the telescoping direction of the boom and the head facing the elevating direction of the boom, due to failure to notice obstacles behind or overhead in time or accidental operation, life-threatening dangers may result. The Secondary Guarding can protect the operator by preventing the operator from being pinched.

 **WARNING**

Unsafe Operation Hazard





- Except for designated models and corresponding markets, it is forbidden to install the Secondary Guarding on other Sinoboom products or any models in other markets.**
- Before using the Secondary Guarding, the safety rules and all operating instructions should be read, understood and observed. This manual should always be kept with the Secondary Guarding as a part of it.**

Fig 1

Table 11-1

No.	Part Number	Part Name	Quantity	Comment
1	203080000101	Waterproof cap	1	
2	203080000109	Slotted nut	1	
3	203060000021	Toggle switch	1	
4	203060000150	Toggle switch guard	1	If equipped

Device Components

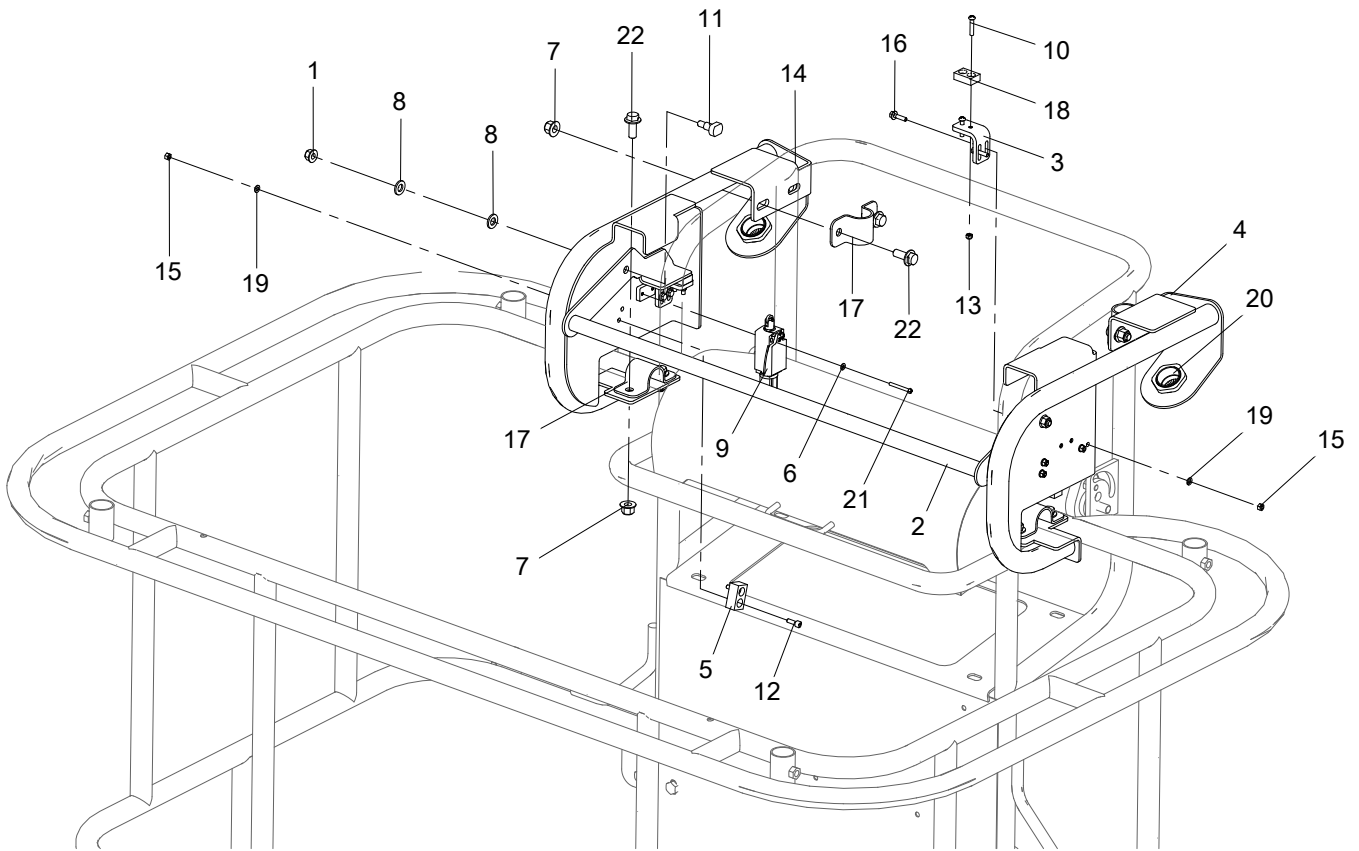

Fig 2

Table 11-2

No.	Part Number	Part Name	Quantity	Comment
1	215030000108	Nut M8-8-ZnD GB/T 6183	2	
2	105070043011	Support	1	
3	105070043028	Foldable plate	2	
4	105070043030	Support	1	
5	103010013495	Cushion block	2	
6	215040000031	Washer 4-A2 GB/T 97.1	4	
7	215030000109	Nut M10-8-ZnD GB/T 6183	8	
8	215040000035	Washer 10-200HV-ZnD GB/T 97.1	4	
9	203060003031	Travel switch (Schneider)	2	
10	215020000113	Screw M5×25-A2-70 GB/T 818	4	
11	105070043031	Bolt	2	
12	215020000007	Screw M5×16-A2-70 GB/T 70.1	4	
13	215030000091	Nut M5-8-A2-70 GB/T 6184	4	
14	105070043032	Support	1	
15	215030000003	Nut M5-A2-70 GB/T 6170	8	

Table 11-2 (Continued)

No.	Part Number	Part Name	Quantity	Comment
16	215010000256	Bolt M5×20-8.8-ZnD GB/T 5789	4	
17	105029043013	Plate	4	
18	209990003011	Magnet	2	
19	215040000032	Washer 5-A2 GB/T 97.1	12	
20	203050003058	Strobe light	2	
21	215020000212	Screw M4×35-A2-70 GB/T 818	4	
22	215010000238	Bolt M10×25-8.8-ZnD GB/T 5789	8	

Installation and Removal

WARNING

Unsafe Operation Hazard

Except for designated models and corresponding markets, it is forbidden to install the foot switch on other Sinoboom products or any models in other markets.

Installation instructions

1. Position the support (#4 or #14) at the mounting position on the platform railing, align the support with the mounting hole on mounting plate #17, and use bolts and nuts to secure the support to the platform railing. Install the support on the other side of the platform in the same way.
2. Align the folded plate #3 with the mounting holes on the left and right supports, tighten it with bolts, washers and nuts, and install the magnet #18 on the foldable plate.
3. Then align the support #2 with the mounting holes on the left and right supports, and make the folded plates on both sides of support #2 attracted by magnets, and tighten it with bolts, washers and nuts.
4. Install the cushion block #5 on the left and right supports in turn, and tighten it with screws, washers and nuts.
5. Install the travel switch #9 on the left and right supports in turn, and tighten it with screws and washers.
6. Install the strobe light #20 on the left and right

supports in turn.

7. Connect the Secondary Guarding harness.

Removal instructions

Disassemble the Secondary Guarding in the reverse order of the installation instructions.

Instructions for Use

1. Under normal circumstances, the foldable plates on both sides of support #2 will be attracted by the magnets below.
2. Press down the railing of support #2 so that the foldable plates on both sides detach from the magnets and cock up, and the travel switch will be disconnected, the left and right strobe lights will flash, and all functions on the platform controller will be disabled.
3. Depress the foot switch while operating the release switch on the platform controller, and the boom can be retracted and lowered, and the turntable can rotate slowly.
4. To enable the boom extending and elevating functions, lift the railing of support #2 up until the foldable plates on both sides are re-attracted by the magnets and the strobe light goes out.

Harness and Schematic Diagram

Secondary Guarding Harness

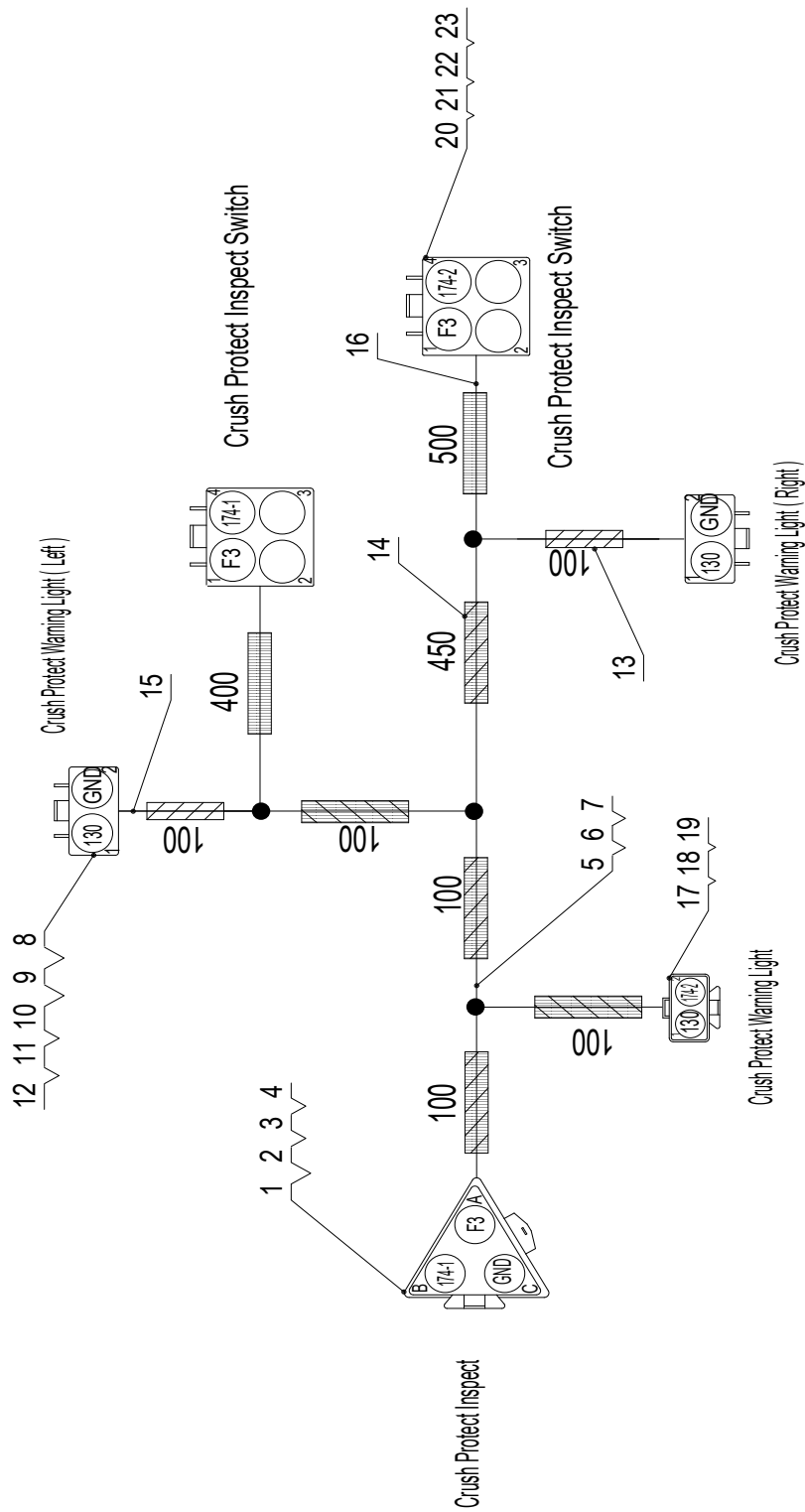

Fig 3

Table 11-3

No.	Part Number	Part Name	Quantity	Comment
1	203080000405	Sheath	1	
2	203080000046	Lock	1	
3	203080000033	Tape-on-reel male terminal	5	
4	203080000466	Tail clamp (3-pin, male)	1	
5	203080003313	Thin-walled automotive wires	2	
6	203080003326	Thin-walled automotive wires	1	
7	203080000564	Thin-walled automotive wires (white)	5	
8	203080000410	Sheath	2	
9	203080000016	Lock	2	
10	203080000041	Tape-on-reel female terminal	8	
11	203080000437	Tail attachment (2-pin, female)	2	
12	203080000448	Rubber connector (2-pin)	2	
13	203080000417	Nylon hose (closed-end)	1	
14	203080000424	Nylon hose (closed-end)	1	
15	203080000563	Thin-walled automotive wires (black)	1	
16	203080000562	Thin-walled automotive wires (red)	1	
17	203080000408	Sheath	1	
18	203080000021	Lock	1	
19	203080000462	Tail attachment (2-pin, male)	1	
20	203080000044	Sheath	2	
21	203080000020	Lock	2	
22	203080000445	Tail attachment (4-pin, female)	2	
23	203080000446	Rubber connector (4-pin)	2	

Wiring Diagram of Platform Controller

The diagram below only shows the wiring related to the Secondary Guarding, and the complete wiring layout can be found in the complete platform controller wiring diagram.

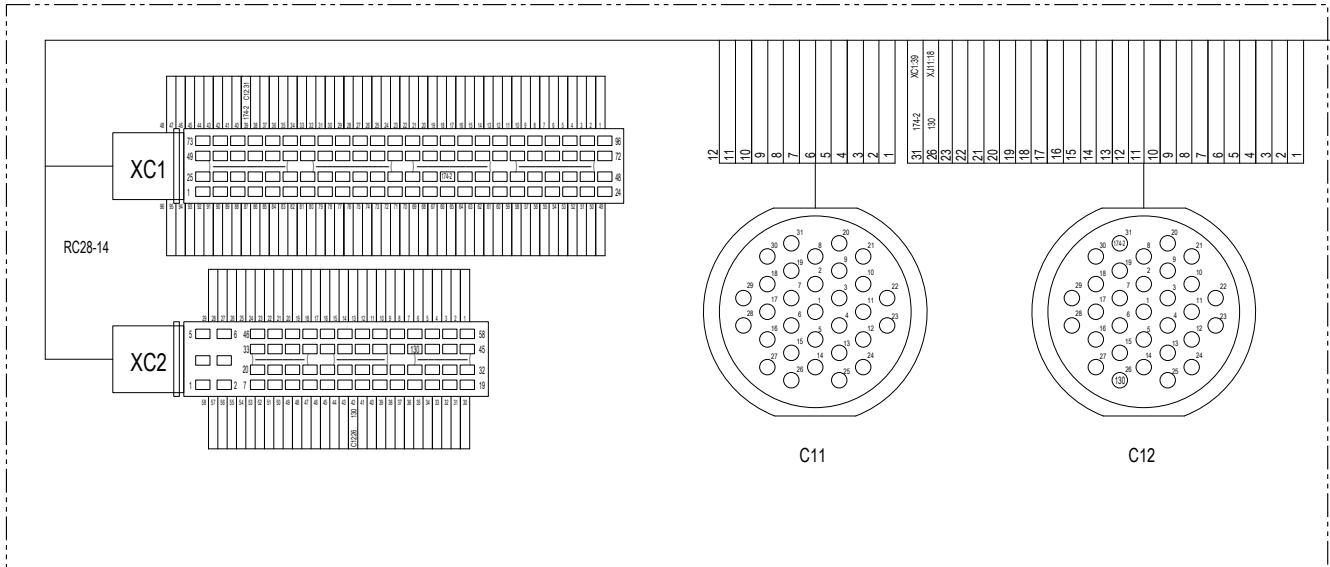

Fig 5

Platform Harness

The figure below only shows the platform harness related to Secondary Guarding, and the complete harness layout can be found in the complete platform harness diagram.

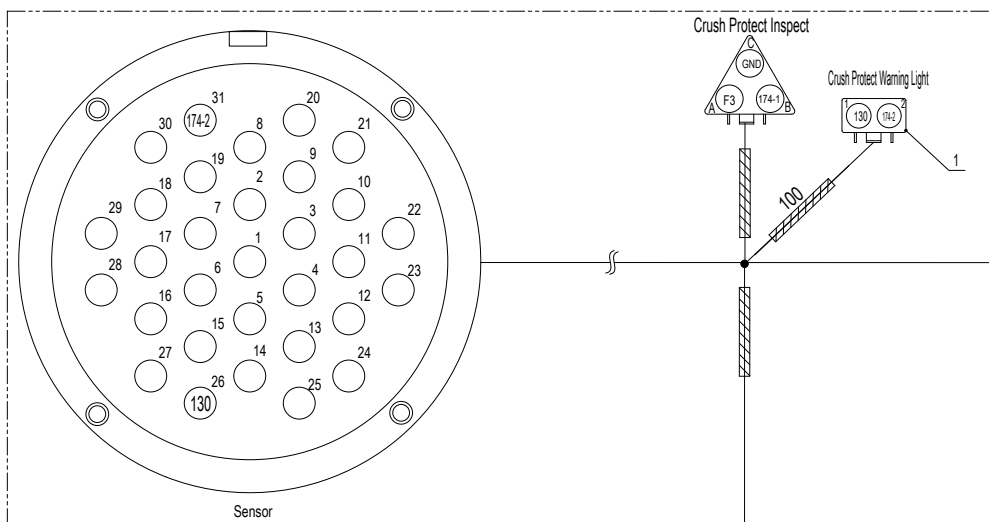

Fig 6

Table 11-4

No.	Part Number	Part Name	Quantity	Comment
1	203080000474	Waterproof cap (2-pin, female terminal)	1	

Electrical Schematic Diagram of Platform

The diagram below only shows the electrical schematic related to the Secondary Guarding, and the complete electrical schematic can be found in the complete electrical schematic diagram of platform.

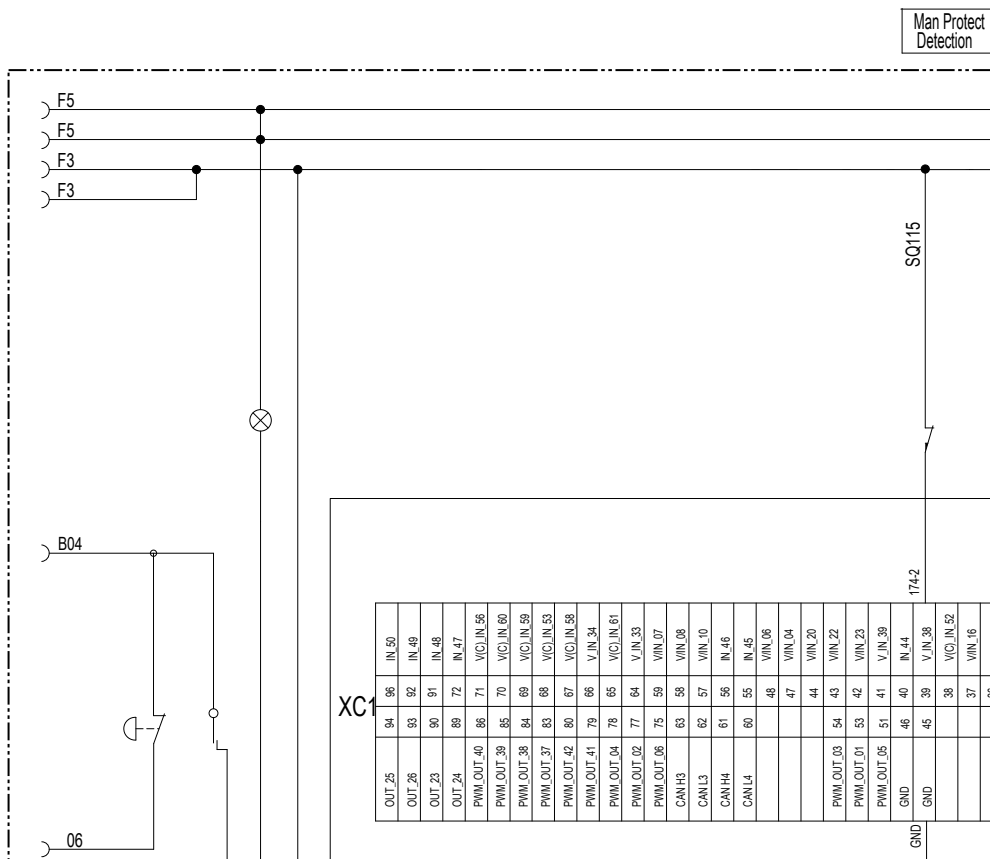

Fig 7

11.2 PIPE CRADLE

Parts List

Self-propelled boom-supported elevating work platforms are designed to transport people, tools and materials to aerial workplaces. When it is needed to transport the pipe materials to an aerial position, the pipe cradle serves as a supporting unit to hold and secure the pipe materials for safe transport.

⚠ WARNING

Unsafe Operation Hazard

- Except for designated models and corresponding markets, it is forbidden to install the pipe cradle on products with other models or in other markets than specified.
- Before using the pipe cradle, the safety rules and all operating instructions should be read, understood and observed. This manual should always be kept as an integral part with the pipe cradle.

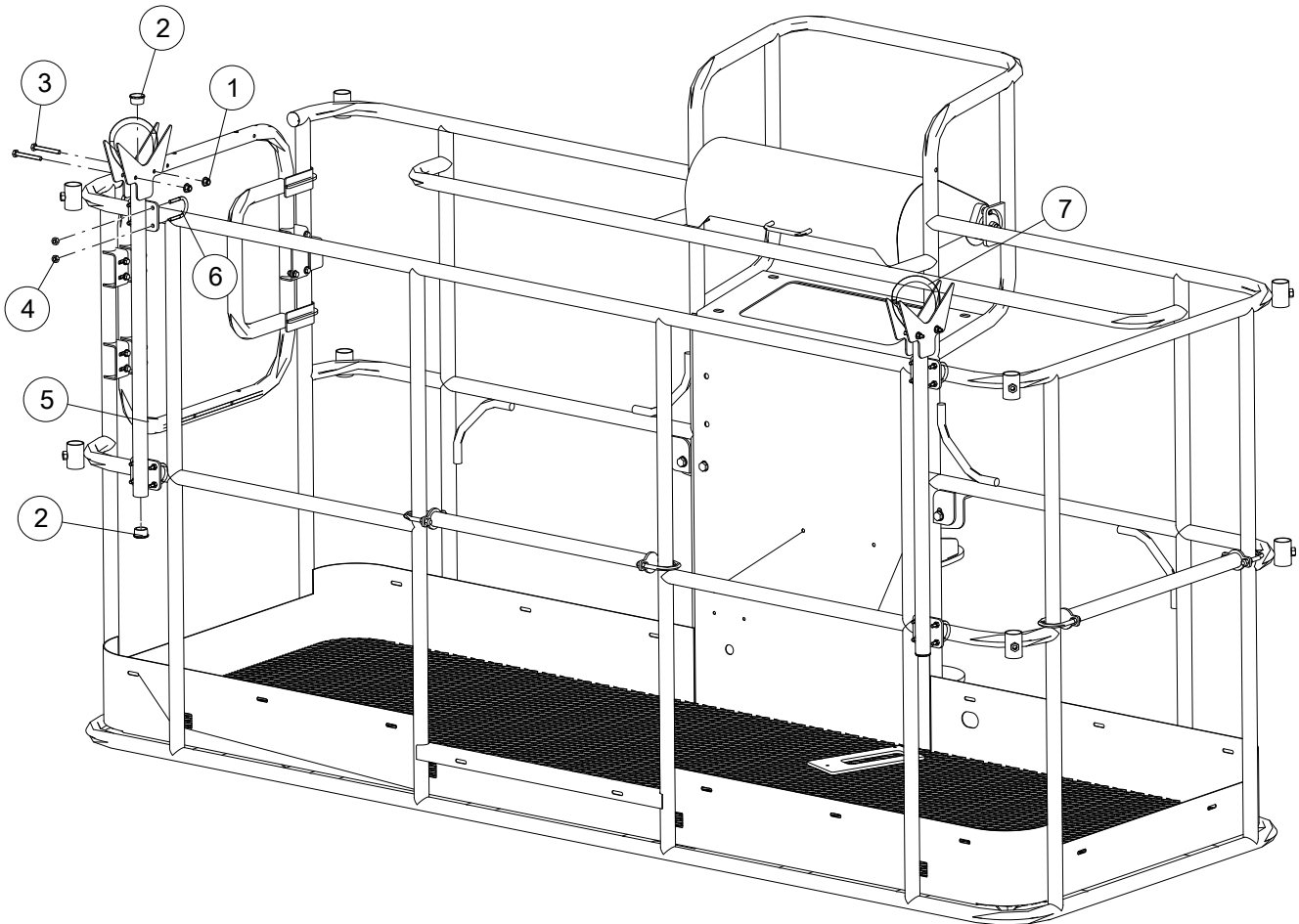



Fig 8

Table 11-5

No.	Part Number	Part Name	Quantity	Comment
1	215030000107	Nut M6-8-ZnD GB/T 6183	4	
2	105064043177	Pipe seal	4	
3	215010000055	Bolt M6×50-A2-70 GB/T 5783	4	
4	215030000004	Nut M6-A2-70 GB/T 6170	18	
5	105064043123	Pipe cradle weldment	1	
6	105064043020	U-bolt	8	
7	\	Strap 400mm*25mm	2	

Installation and Removal

The pipe cradle assembly includes two pieces of pipe cradles secured with U-bolts and nuts to both sides of the guardrails.

! WARNING

Unsafe Operation Hazard



Except for designated models and corresponding markets, it is forbidden to install the pipe cradle on products with other models or in other markets than specified.

! WARNING

Unsafe Operation Hazard



- Read and understand the following safety rules before proceeding to the next step.
- The installation of the pipe cradles shall not obstruct the normal operation of the platform controller.
- The installation of the pipe cradles shall not obstruct the entrance and exit of the platform.
- Before installing the pipe cradles, ensure that the platform remains level.

Installation instructions

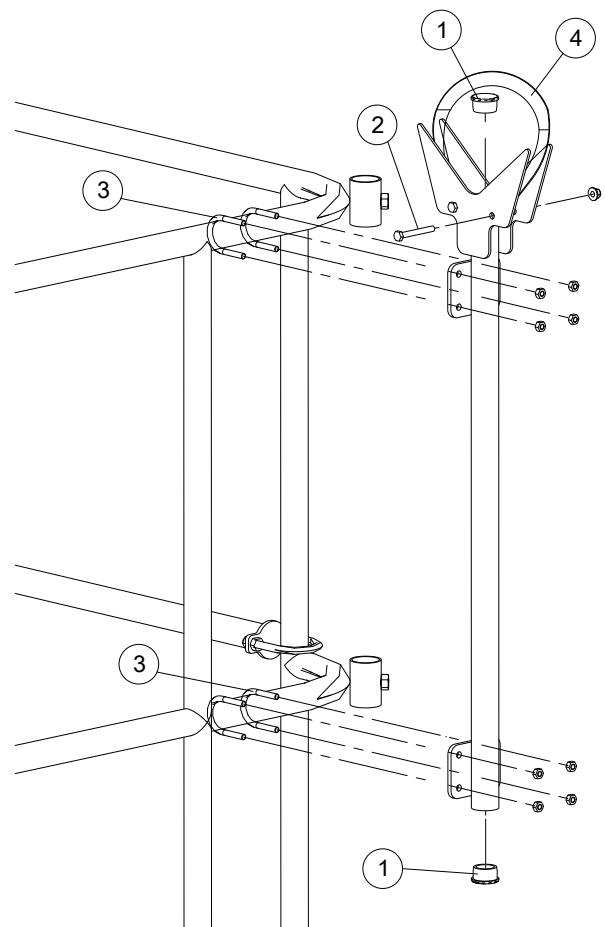

Fig 9

1. Install the top and bottom pipe seals to the pipe cradle weldment.
2. Secure the welding plate on the top of the pipe cradle weldment with bolts.
3. Roughly secure the pipe cradle to one side of the platform, and then tighten the pipe cradle from top to bottom sequentially: insert the U-bolt through the platform guardrails, align it with the mounting holes of the pipe cradle, and then secure it with hex nuts. Install the pipe cradle to the other side of the

platform in the same way.

4. Fasten the strap to tightly secure it to the bracket.

Removal instructions

Disassemble the pipe cradles in the reverse order of the installation instructions.

Instructions for Use

WARNING

Tipping Hazard

- The pipe cradle and the load upon will affect the load capacity of the platform, thus must be factored into the total platform capacity.**
- In case of excessive combined weight of the pipe cradle and the load upon, the maximum number of people on the platform should be reduced.**

Table 11-6

Pipe cradle capacity	100kg (220lbs)
Pipe cradle assembly weight	6kg (13lbs)

After the pipe cradle is installed, follow the below instructions for use:

1. Ensure that the pipe cradles are installed correctly and secured to the platform.
2. Place the load upon the pipe cradle, and ensure that the load length remains parallel with the pipe cradle length.
3. Ensure the load is centered on the same vertical

plane with the center of the pipe cradle.

4. Use the straps to secure the load to the both pipe cradles.
5. Gently push and pull on the load to ensure that the load is securely secured.
6. When the machine is operating, ensure that the load is always secured in place.

11.3 PANEL CRADLE

Self-propelled boom-supported elevating work platforms are designed to transport people, tools and materials to aerial workplaces. When it is needed to transport the panel materials to an aerial position, the panel cradle serves as a supporting unit to hold and secure the panel materials for safe transport.

WARNING

Unsafe Operation Hazard

- Except for designated models and corresponding markets, it is forbidden to install the panel cradle on products with other models or in other markets than specified.**
- Before using the panel cradle, the safety rules and all operating instructions should be read, understood and observed. This manual should always be kept as an integral part with the panel cradle.**

Parts List

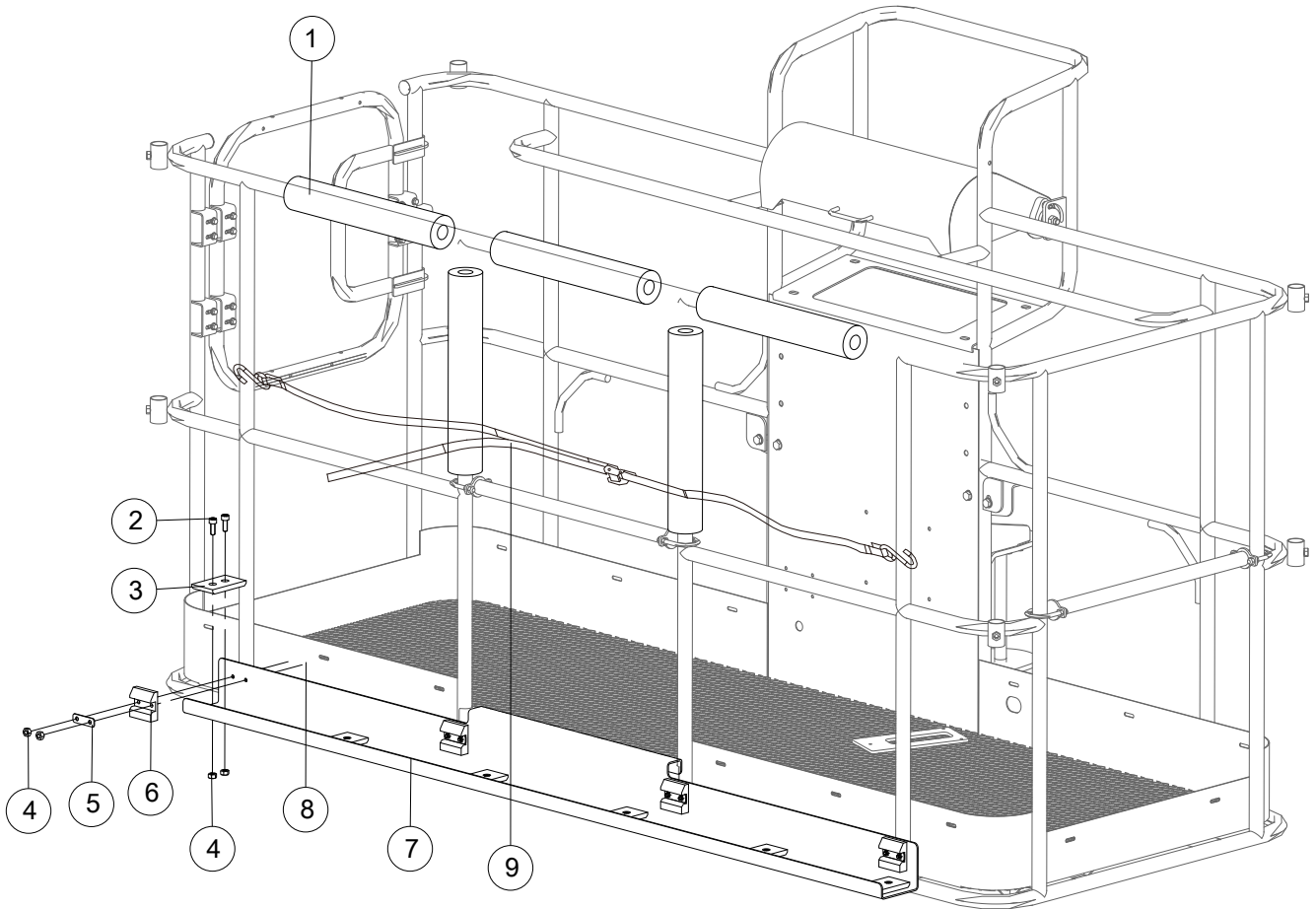

Fig 10

Table 11-7

No.	Part Number	Part Name	Quantity	Comment
1	216030003000	Tube pad	5	
2	215020000011	Screw M6×16-A2-70 GB/T 70.1	12	
3	105064043024	Cushion block	6	
4	215030000004	Nut M6-A2-70 GB/T 6170	20	
5	105064043178	Cushion plate	4	
6	105064043136	Vertical cushion block	4	
7	105064043017	Mounting plate	1	
8	105064043020	U-bolt	4	
9	\	Strap 3000mm*25mm	1	

Installation and Removal

! WARNING

Unsafe Operation Hazard

Except for designated models and corresponding markets, it is forbidden to install the panel cradle on products with other models or in



! WARNING

Unsafe Operation Hazard
other markets than specified.

Installation instructions

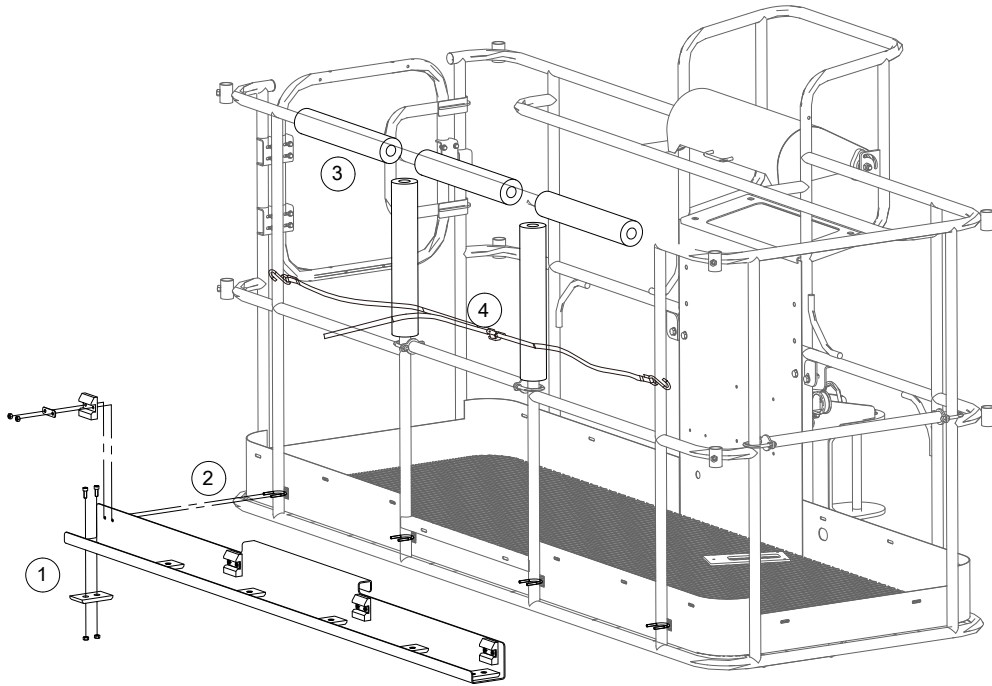

Fig 11

1. Using the bolts and nuts, secure the cushion blocks to the mounting plate of the panel cradle.
2. After roughly securing the mounting plate in place, insert the U-bolt into the holes of the mounting plate and vertical cushion block, and then secure it with the cushion plate and nut. Install other mounting plates sequentially as illustrated.
3. Install the tube pads to the platform guardrails.
4. Attach the straps to the guardrails to secure the mounting plate tightly on the platform.

Removal instructions

Disassemble the panel cradle in the reverse order of the installation instructions.

Instructions for Use

⚠ WARNING

Tipping Hazard



- When the wind speed exceeds 12.5m/s (28mph), do not use the panel cradle.
- The panel cradle and the load upon will affect the load capacity of the platform, thus must be factored into the total platform capacity.
- In case of excessive combined weight of the panel cradle and the load upon, the maximum number of people on the platform should be reduced.
- The panel surface area will expose the machine to an increased load of wind and reduce the stability of the machine.
- Only use the panel cradle when the machine is on flat, solid ground.

Table 11-8

Panel cradle capacity	115kg (253.5lbs)
Panel cradle weight	15.2kg (33.5lbs)
Maximum allowable wind speed	12.5m/s (28mph)
Maximum allowable panel surface area	0.17m ² (1.83sq.ft)
Maximum allowable panel vertical height	1.2m (3ft 11in)

1. Ensure that the panel cradle is installed correctly and secured to the platform.
2. Place the load upon the panel cradle, and ensure that the load length remains parallel with the panel cradle length.

3. Ensure the load is centered on the same vertical plane with the center of the panel cradle.
4. Use the straps to secure the load to the platform.
5. Gently push and pull on the load to ensure that the load is securely secured.
6. When the machine is operating, ensure that the load is always secured in place.

NOTICE



Ensure that the load remains a proper distance from the door bar to prevent abrasion, crush or other damages to the load.

11.4 PLATFORM MESH

The platform mesh comes in two types: half mesh and full mesh, which can effectively prevent tools or other materials from dropping off the platform.

⚠ WARNING

Unsafe Operation Hazard

- Except for designated models and corresponding markets, it is forbidden to install the platform mesh on products with other models or in other markets than specified.
- Before using the platform mesh, the safety rules and all operating instructions should be read, understood and observed. This manual should always be kept as an integral part with the platform mesh.

Parts List

Parts list of half mesh

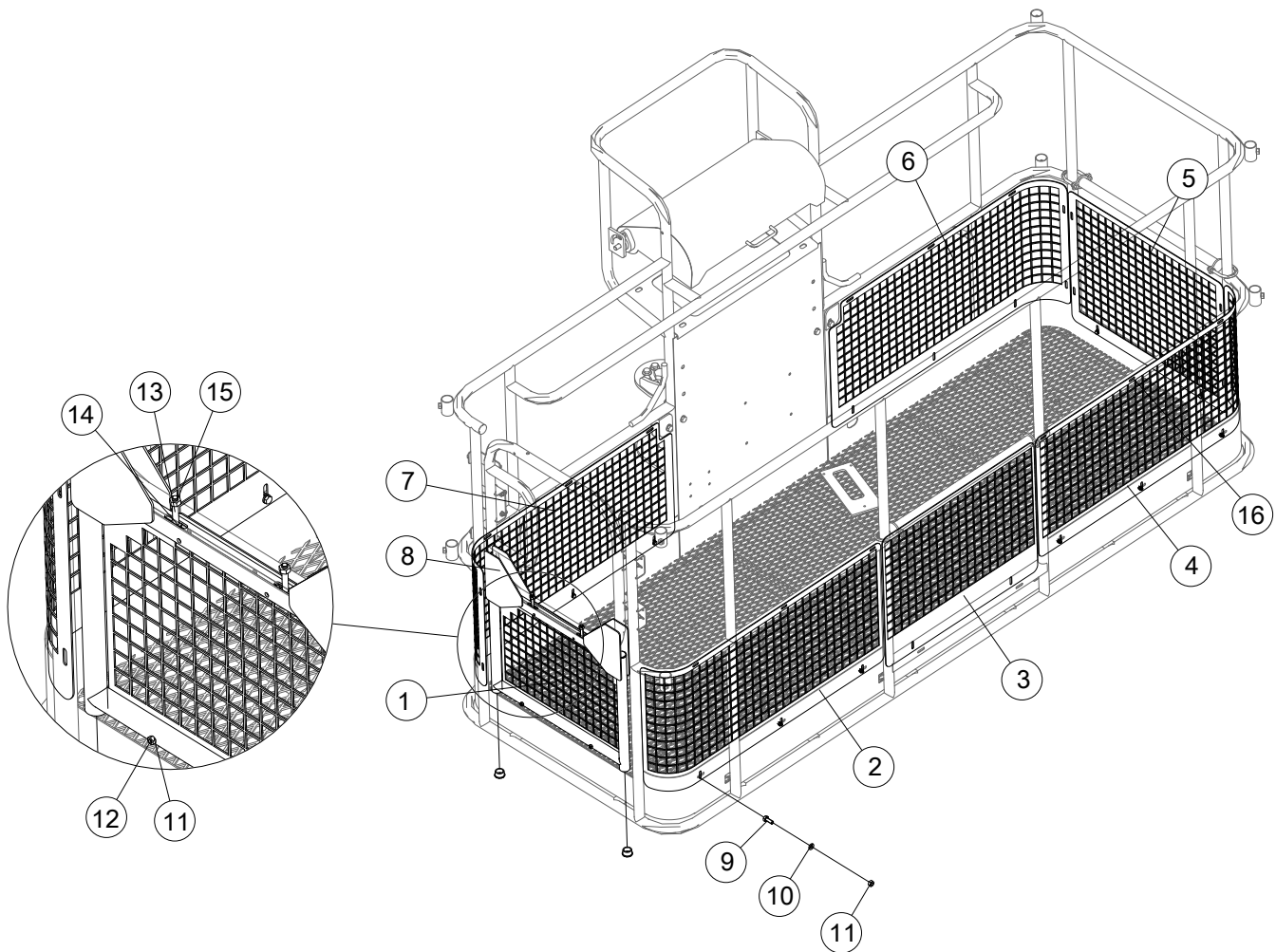

Fig 12

Table 11-9

No.	Part Number	Part Name	Quantity	Comment
1	105064043107	Lower side mesh	1	
2	105064043027	Mesh 1	1	
3	105064043176	Mesh 5	1	
4	105064043175	Mesh 6	1	
5	105064043028	Mesh 2	1	
6	105064043030	Mesh 3	1	
7	105064043031	Mesh 4	1	
8	105064043103	Lower gate frame weldment	1	
9	215010000050	Bolt M6×16-A2-70 GB/T 5783	16	
10	215040000033	Washer 6-A2 GB/T 97.1	18	

Table 11-9 (Continued)

No.	Part Number	Part Name	Quantity	Comment
11	215030000004	Nut M6-A2-70 GB/T 6170	18	
12	2150100000054	Bolt M6×40-A2-70 GB/T 5783	2	
13	2150100000062	Bolt M8×45-8.8-ZnD GB/T 5783	2	
14	2150400000034	Washer 8-200HV-ZnD GB/T 97.1	2	
15	2150300000005	Nut M8-8-ZnD GB/T 6170	2	
16	\	Nylon cable tie	\	

Parts list of full mesh

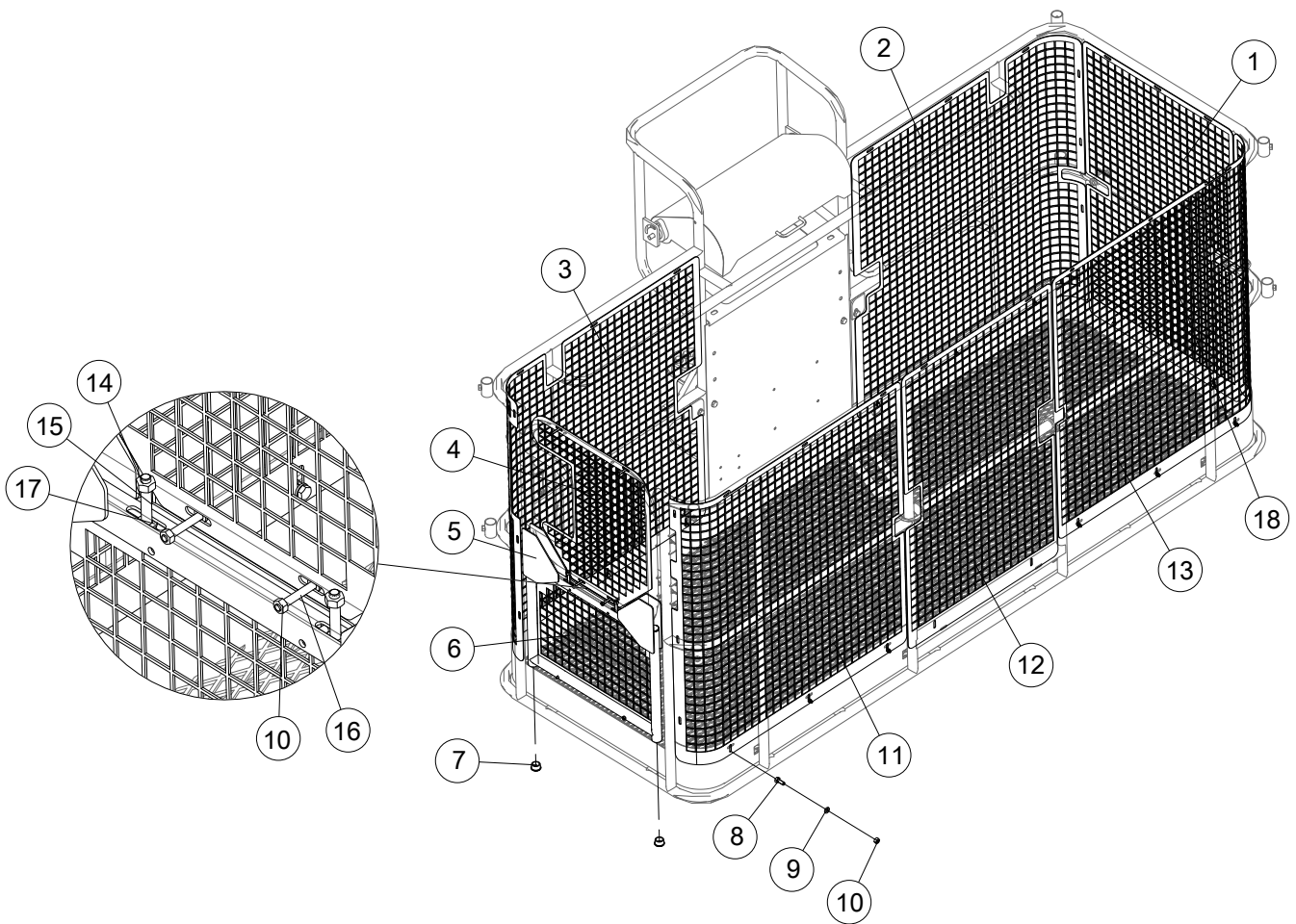

Fig 13

Table 11-10

No.	Part Number	Part Name	Quantity	Comment
1	105064043106	Side mesh	1	
2	105064043109	Front right mesh	1	
3	105064043110	Front left mesh	1	
4	105064043114	Upper side mesh	1	

Table 11-10 (Continued)

No.	Part Number	Part Name	Quantity	Comment
5	105064043103	Lower gate frame weldment	1	
6	105064043107	Lower side mesh	1	
7	105064043177	Pipe seal	4	
8	215010000050	Bolt M6×16-A2-70 GB/T 5783	17	
9	215040000033	Washer 6-A2 GB/T 97.1	23	
10	215030000004	Nut M6-A2-70 GB/T 6170	23	
11	105064043108	Back left mesh	1	
12	105064043112	Back mesh	1	
13	105064043118	Back right mesh	1	
14	215030000005	Nut M8-8-ZnD GB/T 6170	2	
15	215010000062	Bolt M8×45-8.8-ZnD GB/T 5783	2	
16	215010000054	Bolt M6×40-A2-70 GB/T 5783	6	
17	215040000034	Washer 8-200HV-ZnD GB/T 97.1	2	
18	\	Nylon cable tie	\	

Installation and Removal

WARNING

Unsafe Operation Hazard

- Except for designated models and corresponding markets, it is forbidden to install the platform mesh on products with other models or in other markets than specified.
- The platform mesh can only be installed on the platform equipped with swing gate.

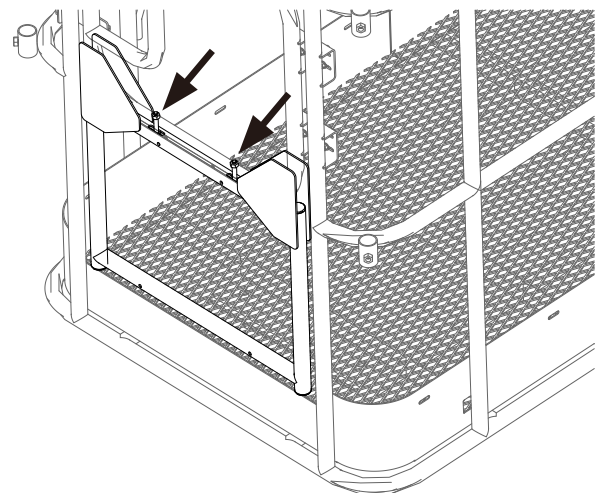

Fig 14

Installation instructions

1. Install the gate frame weldment to the swing gate.
2. Half mesh: Install each mesh in sequence as shown in the figure below, secure the mesh bottom ① with bolts, and secure the mesh top ② and side mesh ③ with nylon cable ties or bolts.

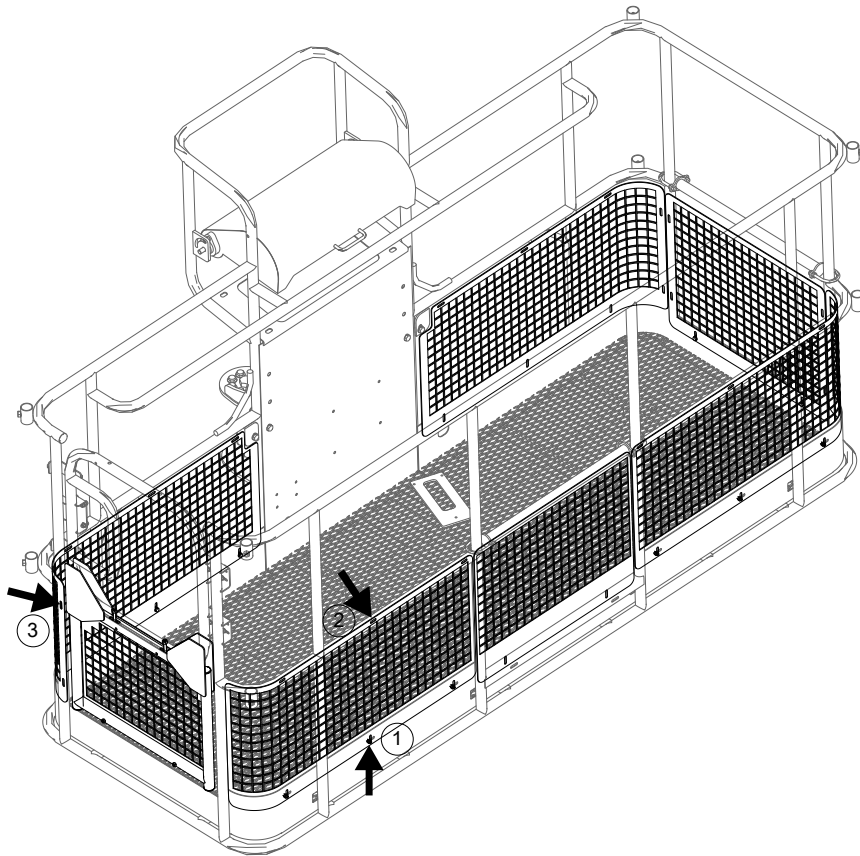

Fig 15

3. Full mesh: Install each mesh in sequence as shown in the figure below, secure the mesh bottom ① with

bolts, and secure the mesh top ② and side mesh ③ with nylon cable ties or bolts.

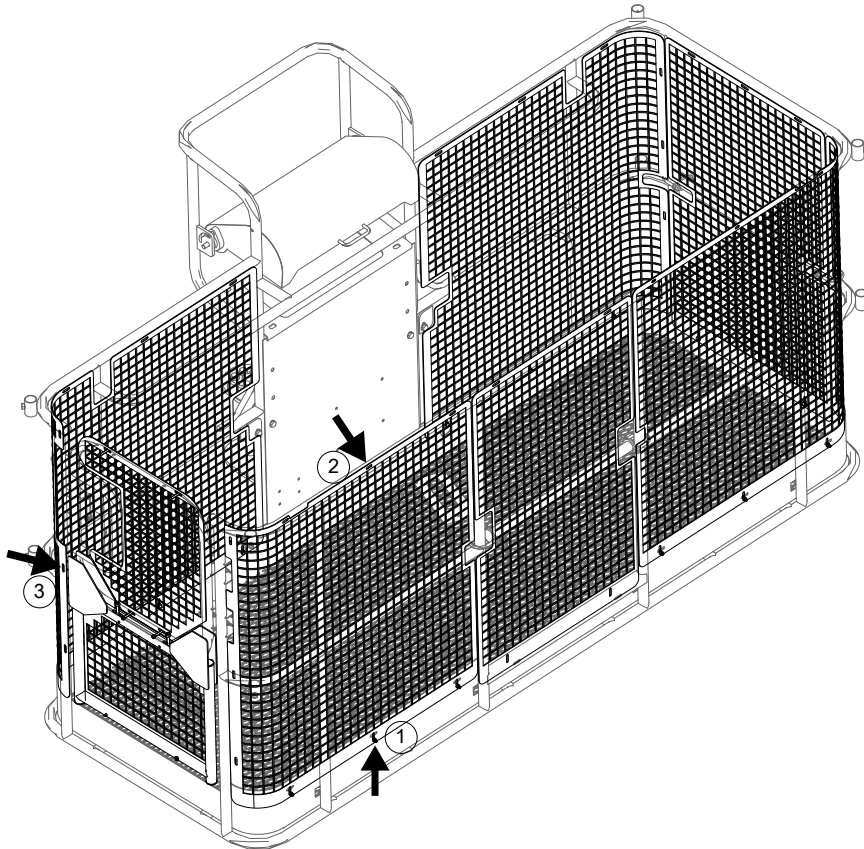

Fig 16

Removal instructions

Disassemble the platform mesh in the reverse order of the installation instructions.

Instructions for Use

- After the platform mesh is installed, the operator can only enter or exit the platform via the swing gate.
- Do not install other attachments, such as pipe/panel cradles, to the platform already fitted with platform mesh.

This Page Intentionally Left Blank

Major Modification and Repair Record			
<p>Note:</p> <ol style="list-style-type: none"> 1. A major modification/repair is a modification/repair made to the entire machine or its parts that affects the stability, strength or performance of the machine. 2. A major modification/repair to the machine should be documented with the form below. Keep the form properly until the machine is taken out of service, or as requested by the machine owner/company. 3. The machine must be inspected and verified after major modifications/repairs, with the inspection items including but not limited to all items in the Inspection and Preventative Maintenance Schedule. After all the inspection and verification results are good, the machine can be put back into service. 			

12.2 INSPECTION AND PREVENTATIVE MAINTENANCE SCHEDULE

The inspection cycle is based on the use of machine under normal working conditions, and the cycle should be shortened accordingly if the machine is used in harsh working conditions.

Perform inspection and preventive maintenance for the items in the table below at prescribed intervals. The intervals of inspection and maintenance are calculated based on the months elapsed since the machine has been put into service or the “cumulative working time” on the turntable controller display (whichever comes first).

Table 12-1 Inspection and Preventative Maintenance Schedule

Items	Intervals		
	Before each delivery ¹ or quarterly ²	Semiannually ³	Annually ⁴
Chassis assembly			
Chassis	2	2	2
Tire	1, 2	1, 2	1, 2
Wheel fastener	1 ⁵⁰	1 ⁵⁰	1 ⁵⁰
Travel motor	1, 2	1, 2	1, 2
Travel reducer	1, 2, 6	1, 2, 6	1, 2, 6, 11
Steering component	1, 2	1, 2	1, 2
Outrigger, telescopic shaft (if equipped)	1, 2, 3	1, 2, 3	1, 2, 3
Bearing	1, 2, 5, 12	1, 2, 5, 12	1, 2, 5, 12
Turntable assembly			
Turntable	2	2	2
Slewing bearing or slewing reducer	1 ⁵⁰ , 2, 6, 12	1 ⁵⁰ , 2, 6, 12	1 ⁵⁰ , 2, 6, 8, 12
Slewing reducer (if equipped)	1, 2, 6	1, 2, 6	1, 2, 6, 11
Central rotary joint	6	6	6

Table 12-1 Inspection and Preventative Maintenance Schedule (Continued)

Items	Intervals		
	Before each delivery ¹ or quarterly ²	Semiannually ³	Annually ⁴
Slewing motor	1, 6	1, 6	1, 6
Turntable pin (if equipped)	1, 2, 3	1, 2, 3	1, 2, 3
Turntable cover assembly	1, 2, 3	1, 2, 3	1, 2, 3
Boom assembly			
Boom weldment	1, 2	1, 2	1, 2
Hose or wire rope bracket	1, 2	1, 2	1, 2
Pulley and slider assembly	1, 2	1, 2	1, 2
Bearing	1, 2, 5, 12	1, 2, 5, 12	1, 2, 5, 12
Cover or protective guard (if equipped)	1, 2	1, 2	1, 2
Drag chain or wire rope system (if equipped)	1, 2, 3, 5	1, 2, 3, 5	1, 2, 3, 5
Pivot pin and retaining ring	1, 2	1, 2	1, 2
Platform assembly			
Guardrail	2	2	2
Access gate	1, 2, 3	1, 2, 3	1, 2, 3
Floor	2	2	2
Swing cylinder	1, 2, 5, 6	1, 2, 5, 6	1, 2, 5, 6
Safety belt anchorage point	1, 2, 7	1, 2, 7	1, 2, 7
Hydraulic system			
Hydraulic pump	1, 2, 6	1, 2, 6	1, 2, 6
Hydraulic cylinder	1, 2, 5, 6	1, 2, 5, 6	1, 2, 5, 6
Oscillating cylinder exhausting (if equipped)	10 ^{NO.1}	10 ^{NO.1}	10 ^{NO.1}
Hydraulic valve	1, 2, 5, 6	1, 2, 5, 6	1, 2, 5, 6
Counterbalance valve locking check (if equipped)	10 ^{NO.1}	10 ^{NO.1}	10 ^{NO.1}
Hydraulic connecting pin and retaining ring	1, 2	1, 2	1, 2
Hydraulic hose, pipeline and joint	1, 2, 6	1, 2, 6	1, 2, 6
Hydraulic tank, cap and vent	1, 2, 3, 5, 6	1, 2, 3, 5, 6	1, 2, 3, 5, 6
Hydraulic oil filter	1, 5, 6	1, 5, 6, 11 ⁵⁰	1, 5, 6, 11 ⁵⁰
Hydraulic oil	5, 6	5, 6	5, 6, 11
Electrical system			

Table 12-1 Inspection and Preventative Maintenance Schedule (Continued)

Items	Intervals		
	Before each delivery ¹ or quarterly ²	Semiannually ³	Annually ⁴
Electrical wiring, connector	1, 2	1, 2	1, 2
Battery	1, 2, 6, 9, 12	1, 2, 6, 9, 12	1, 2, 6, 9, 12
Electrolyte	6	6	6
Charging function	3	3	3
Instrument, meter, switch, lamp, horn	1, 3	1, 3	1, 3
Functions and controls			
Platform controller	1, 3, 4, 7, 10	1, 3, 4, 7, 10	1, 3, 4, 7, 10
Turntable controller	1, 3, 4, 7, 10	1, 3, 4, 7, 10	1, 3, 4, 7, 10
Function control lock, protective device and brake	1, 3, 10	1, 3, 10	1, 3, 10
Foot switch	1, 3, 10	1, 3, 10	1, 3, 10
Emergency stop button (ground and platform)	1, 3, 10	1, 3, 10	1, 3, 10
Limit switch and main power switch	1, 3, 10	1, 3, 10	1, 3, 10
Pothole protection device (if equipped)	1, 3, 10	1, 3, 10	1, 3, 10
Overload limit system	1, 3, 10	1, 3, 10	1, 3, 10
Tilt alarm device	1, 3, 10	1, 3, 10	1, 3, 10
Drive brake	1, 3, 10	1, 3, 10	1, 3, 10
Rotation brake	1, 3, 10	1, 3, 10	1, 3, 10
Other inspection items			
Operation Manual in the manuals storage box	10	10	10
All decals/labels complete, clear and secure	10	10	10
Annual inspection date of the machine	/	/	10
No unapproved changes or additions	10	10	10
All safety publications included	10	10	10
General structural components and welds	2	2	2
All fasteners, pins, protective guards and covers	1, 2	1, 2	1, 2
Grease and lubricating to specifications	10	10	10
Functional test of all systems	10	10	10

Table 12-1 Inspection and Preventative Maintenance Schedule (Continued)

Items	Intervals		
	Before each delivery ¹ or quarterly ²	Semiannually ³	Annually ⁴
Paint and appearance	5	5	5
Inspection date stamped on the chassis	/	/	10
Notify Sinoboom of machine ownership	/	/	10

Note:

¹ Before each sale, lease or shipment;

² In service for 3 months or 250 hours; or out of service for more than 3 months;

³ In service for 6 months or 500 hours;

⁴ Once a year and no later than 13 months from the date of the prior annual machine inspection;

⁵⁰ The first inspection work shall be performed after the machine has been in service for 50 hours for the first time; This only happens once in the service life of the machine;

²⁵⁰ The first inspection work shall be performed after the machine has been in service for 250 hours for the first time. This only happens once in the service life of the machine.

NO.1 Before the machine is put into service for the first time, or before the first use after the oscillating cylinder or counterbalance valve is replaced.

Performance code:

- 1.** Check for correct installation (accurate position, firmly installed, tightened according to the specified torque)
- 2.** Visual inspection for damage (cracks, cracked welds, deformation, wear, corrosion, excessive wear, gouges, abrasions and exposed threads)
- 3.** Check for normal function
- 4.** Return to neutral position or “off” position normally (the self-reset switch can return to neutral position or “off” position after released)
- 5.** Clean and free of foreign objects
- 6.** Check for correct sealing, leaking and level
- 7.** Labels complete, clear and secure
- 8.** Check for appropriate tolerances
- 9.** Fully charged
- 10.** Validation/Execution
- 11.** Replace the oil or filter element
- 12.** Correctly lubricated

This Page Intentionally Left Blank

Always for Better Access Solutions



Hunan Sinoboom Intelligent Equipment Co., Ltd.

No.128, East Jinzhou Avenue, Ningxiang High-tech Industrial Park, Changsha, Hunan, China

☎ 0086-0731-87116222 (Sales) & 0086-0731-87116333 (Service)

✉ sales@sinoboom.com

🏠 www.sinoboom.com

North American Subsidiary

Sinoboom North American LLC

310 Mason Creek Drive
unit #100

Katy, TX 77450, US

Tel: (281) 729-5425

E-mail: info@sinoboom.us

Europe Subsidiary

Sinoboom B.V.

Nikkelstraat 26, NL-2984 AM Ridderkerk,
The Netherlands

Tel: +31 180 225 666

E-mail: info@sinoboom.eu

Korea Subsidiary

Sinoboom Korea Co., Ltd.

95, Docheong-ro, Yeongtong-gu, Suwon-si,
Gyeonggi-do, Republic of Korea

Tel: 010-8310-8026

E-mail: ka1@sinoboom.com

Australia Subsidiary

Sinoboom Intelligent Equipment Pty Ltd.

50/358 Clarendon St, South Melbourne VIC
3205, Australia

E-mail: au@sinoboom.com

Singapore Subsidiary

Star Access Solutions Pte. Ltd.

112 Robinson Road #03-01 Robinson 112
Singapore 068902

Poland Subsidiary

Sinoboom Poland sp. z o.o.

Ul. Bolesława Krzywoustego 74A
61-144 Poznań, Poland