



# SELF-PROPELLED LIFT HA151

242 032 3860 - E 06.04 GB



ISO 9001  
GROUPE  
PINGUELY  
HAULOTTE



ARTICULEES



MATS



TELESCOPIQUES



CISEAUX



TRACTEES

**Haulotte** 

L'ACCES A L'ESPACE

PINGUELY HAULOTTE • LA PERONNIERE - BP 9 - 42152 L'HORME • Tél. +33 (0) 4 77 29 24 24 • Fax SAV +33 (0) 4 77 29 98 88  
email [haulotte@haulotte.com](mailto:haulotte@haulotte.com) • Web [www.haulotte.com](http://www.haulotte.com)



**Distribué par / Distributed by/ Distribuito da**

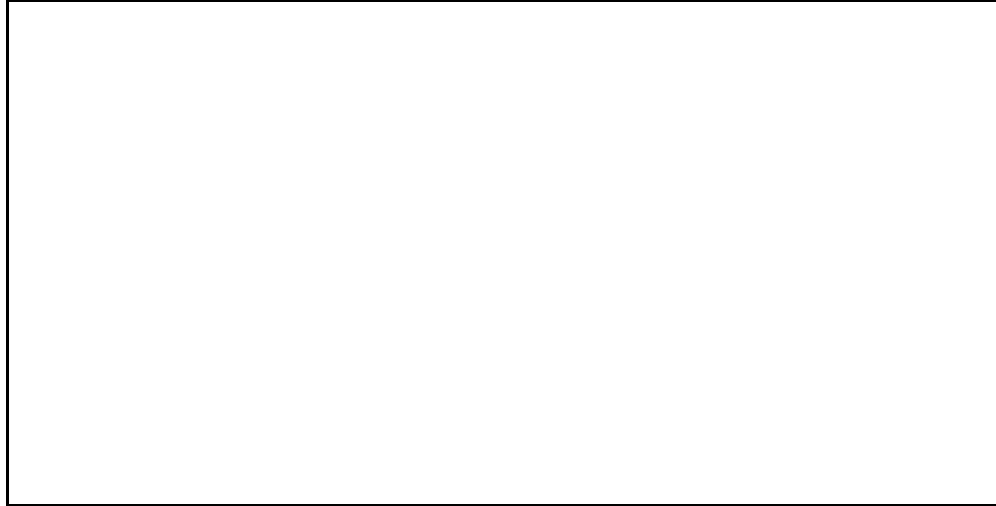

**Haulotte France**

Tél / Phone +33 (0)4 72 88 05 70  
Fax / Fax +33 (0)4 72 88 01 43



**Centre Mondial Pièces de Rechange  
Spare Parts International Centre**

Tél / Phone +33 (0)4 77 29 24 51  
Fax / Fax +33 (0)4 77 29 98 88



**Haulotte Hubarbeitsbühnen**

Tél / Phone + 49 76 33 806 920  
Fax / Fax + 49 76 33 806 82 18



**Haulotte Portugal**

Tél / Phone + 351 21 955 98 10  
Fax / Fax + 351 21 995 98 19



**Haulotte UK**

Tél / Phone + 44 (0) 1952 292753  
Fax / Fax<sup>2</sup> + 44 (0) 1952 292758



**Haulotte U.S. Inc.**

Main tool free 1-877-HAULOTTE  
Service tool free 1-877-HAULOT-S



**Haulotte Asia**

Tél / Phone + 65 6536 3989  
Fax / Fax + 65 6536 3969



**Haulotte Netherlands BV**

Tél / Phone + 31 162 670 707  
Fax / Fax + 31 162 670 710



**Haulotte Australia PTY Ltd**

Tél / Phone + 61 3 9706 6787  
Fax / Fax + 61 3 9706 6797



**Haulotte Italia**

Tél / Phone + 39 05 17 80 813  
Fax / Fax + 39 05 16 05 33 28



**Haulotte Do Brazil**

Tél / Phone + 55 11 3026 9177  
Fax / Fax + 55 3026 9178



**Haulotte Scandinavia AB u.b.**

Tél / Phone + 46 31 744 32 90  
Fax / Fax + 46 31 744 32 99



**Haulotte Iberica - Madrid**

Tél / Phone + 34 91 656 97 77  
Fax / Fax + 34 91 656 97 81



**Haulotte Portugal**

Tél / Phone + 351 21 955 98 10  
Fax / Fax + 351 21 995 98 19



**Haulotte Iberica - Sevilla**

Tél / Phone + 34 95 493 44 75  
Fax / Fax + 34 95 463 69 44



---

## GENERAL

---

This manual gives the information required for you to perform servicing and repair operations on certain pieces of equipment yourself.

However, we would like to bring your attention to the importance of:

- respecting the safety instructions concerning the machine itself, its use and its environment,
- use within the limits of its performance,
- correct servicing to ensure long service life.

During and after the guarantee period, our After-Sales service is available to perform any servicing operations you may require.

In this case, contact our local agency or our Plant After-Sales service, specifying the exact type of machine and its serial number.

To order consumables or spare parts, use the "Instructions for use and maintenance" manual and the "Spare parts" catalogue to order original parts, the only guarantee of interchangeability and perfect operation.

REMINDER: We would like to remind you that our machines comply with the clauses of the "Machines Directive", 89/392/CEE, dated June 14th 1989, modified by directives 91/368/CEE, dated June 21st 1991, 93/44/CEE, dated June 14th 1993, 93/68/CEE (98/37/CE) dated July 22nd 1993 and 89/336 CEE, dated May 3rd 1989; to directive 2000/14/CE and directive EMC/89/336/CE.



Caution!

***The technical data in this manual is not binding and we reserve the right to make improvements or modifications without altering this manual.***

---



---

## SUMMARY

---

|   |  |          |
|---|--|----------|
| <b>GENERAL</b> .....                                    |  | <b>1</b> |
| <b>1 - GENERAL RECOMMENDATIONS - SAFETY</b> .....       |  | <b>1</b> |
| 1.1 - GENERAL WARNING .....                             |  | 1        |
| 1.1.1 - Manual .....                                    |  | 1        |
| 1.1.2 - Labels .....                                    |  | 1        |
| 1.1.3 - Safety .....                                    |  | 1        |
| 1.2 - GENERAL SAFETY RECOMMENDATIONS .....              |  | 2        |
| 1.2.1 - Operators .....                                 |  | 2        |
| 1.2.2 - Environment .....                               |  | 2        |
| 1.2.3 - Using the machine .....                         |  | 2        |
| 1.3 - RESIDUAL RISKS .....                              |  | 4        |
| 1.3.1 - Risks of jerky movements and tipping over ..... |  | 4        |
| 1.3.2 - Electrical risk .....                           |  | 4        |
| 1.3.3 - Risk of explosion or burning .....              |  | 4        |
| 1.3.4 - Risks of collision .....                        |  | 4        |
| 1.4 - INSPECTIONS .....                                 |  | 5        |
| 1.4.1 - Periodic inspections .....                      |  | 5        |
| 1.4.2 - Examination of machine suitability .....        |  | 5        |
| 1.4.3 - State of conservation .....                     |  | 5        |
| 1.5 - REPAIRS AND ADJUSTMENTS .....                     |  | 6        |
| 1.6 - VERIFICATIONS WHEN RETURNING TO SERVICE .....     |  | 6        |
| 1.7 - BEAUFORT SCALE .....                              |  | 6        |
| <b>2 - PRESENTATION</b> .....                           |  | <b>7</b> |
| 2.1 - TECHNICAL CHARACTERISTICS .....                   |  | 7        |
| 2.1.1 - HA15I technical characteristics .....           |  | 7        |
| 2.1.2 - HA15I dimensions .....                          |  | 9        |
| 2.2 - TIGHTENING TORQUE .....                           |  | 10       |

---

|   |           |
|---|-----------|
| 2.2.1 - Large thread screw tightening torque values ..... | 10        |
| 2.2.2 - Small thread screw tightening torque values.....  | 10        |
| 2.2.3 - Wheel tightening torque values .....              | 10        |
| 2.2.4 - Hydraulic hose tightening torque values .....     | 11        |
| 2.2.5 - TPressure table (bar) .....                       | 11        |
| 2.2.6 - Table of adjustment times .....                   | 12        |
| <br>  |           |
| <b>3 - SAFETY SYSTEMS.....</b>                            | <b>13</b> |
| 3.1 - MACHINE ELEMENTS .....                              | 13        |
| 3.1.1 - Turntable box and chopper plate.....              | 13        |
| 3.1.2 - Safety contacts.....                              | 13        |
| <br>  |           |
| <b>4 - WIRING DIAGRAMS .....</b>                          | <b>15</b> |
| 4.1 - FOLIO 1 .....                                       | 15        |
| 4.2 - FOLIO 2 .....                                       | 16        |
| 4.3 - FOLIO 3 .....                                       | 17        |
| 4.4 - FOLIO 4 .....                                       | 18        |
| <br>  |           |
| <b>5 - HYDRAULIC DIAGRAMS .....</b>                       | <b>19</b> |
| 5.1 - HYDRAULIC DIAGRAM.....                              | 19        |
| 5.2 - HYDRAULIC DIAGRAM.....                              | 20        |
| <br>  |           |
| <b>6 - MAINTENANCE.....</b>                               | <b>21</b> |
| 6.1 - GENERAL RECOMMENDATIONS.....                        | 21        |
| 6.2 - SPECIFIC RECOMMENDATIONS .....                      | 21        |
| 6.2.1 - Specific tools .....                              | 21        |
| 6.2.2 - Replacing a part .....                            | 21        |
| 6.2.3 - Locating the breakdown .....                      | 21        |
| 6.2.4 - Protecting the environment .....                  | 22        |
| 6.3 - MAINTENANCE SYSTEM .....                            | 22        |
| 6.4 - ELECTRIC POWER SUPPLY .....                         | 22        |
| 6.5 - MAINTENANCE PLAN.....                               | 23        |

---

---

|   |            |
|---|------------|
| 6.5.1 - Maintenance plan.....                     | 24         |
| 6.6 - OPERATIONS .....                            | 25         |
| 6.7 - PRESENCE OF LABELS .....                    | 25         |
| 6.7.1 - Label positions .....                     | 27         |
| <br>  |            |
| <b>7 - PREVENTIVE MAINTENANCE SHEETS.....</b>     | <b>29</b>  |
| <br>  |            |
| <b>8 - OPERATING INCIDENTS.....</b>               | <b>39</b>  |
| 8.1 - CHOPPER DISPLAY.....                        | 40         |
| 8.2 - TROUBLESHOOTING.....                        | 41         |
| <br>  |            |
| <b>9 - CORRECTIVE MAINTENANCE PROCEDURES.....</b> | <b>127</b> |



# 1 - GENERAL RECOMMENDATIONS - SAFETY

## 1.1 - GENERAL WARNING

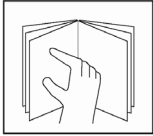

### 1.1.1 - Manual

This manual aims to help maintenance personnel service and repair the machine. It cannot, however, replace the basic training required by any person working on the site equipment.

The site manager must inform operators of the recommendations in the instruction manual. He is also responsible for application of current "user regulations" in the country of use.

Before operating on the machine, it is essential to be familiar with all the recommendations in this manual and the user manual to ensure personnel and equipment safety.

### 1.1.2 - Labels

Potential dangers and recommendations for the machine are indicated on labels and plates. Read the instructions on them.

All labels conform to the following colour code:

- Red indicates a potentially fatal danger.
- Orange indicates a danger that may cause serious injury.
- Yellow indicates a danger that may cause material damage or slight injury.

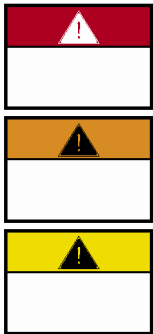

Maintenance personnel must ensure that these labels and plates are in good conditions and keep them legible. Spare labels and plates can be supplied by the manufacturer on request.

### 1.1.3 - Safety

Ensure that any person entrusted with the machine is take the safety measures implied by its use.

Avoid any working mode that may affect safety. Any use that does not comply with the recommendations may generate risks and damage to people and equipment.

*After intervention, maintenance personnel must check that the operator manual is present. This must be kept by the user throughout the machine's service life, even if it is loaned, rented or sold.*

*Ensure that all the plates or labels related to safety and danger are complete and legible.*



**Caution!**

**To attract the reader's attention, instructions are indicated by this standardised sign.**

## 1.2 - GENERAL SAFETY RECOMMENDATIONS

### 1.2.1 - Operators

Operators must be aged 18 or over and hold an operating permit issued by the employer after verification of medical aptitude and the practical platform operation test.

 **Caution!**  
**Only trained operators may use Haulotte self-propelled platforms.**

There must be at least two operators present, so that one of them can:

- intervene rapidly if necessary,
- take over the controls in the case of accident or breakdown,
- monitor and prevent machines or people from circulating around the platform,
- guide the platform operator if necessary.

### 1.2.2 - Environment

Never use the machine:

- On soft, unstable or cluttered floors.
- On a floor with a tilt greater than the allowed limit.
- With a windspeed above the permitted level. In case of outdoor use, check that windspeed is lower or equal to the permitted level using an anemometer.
- Near electric lines (find out about minimum distances according to current). In temperatures of less than  $-15^{\circ}\text{C}$  (in particular, in cold rooms); consult our service department if work is required in conditions below  $-15^{\circ}\text{C}$ .
- In an explosive atmosphere.
- In an incorrectly ventilated area, as exhaust fumes are toxic.
- During storms (risk of being struck by lightning).
- At night if the machine is not equipped with an optional light.
- In the presence of intense electromagnetic fields (radar, mobile and high current).

**DO NOT DRIVE ON THE PUBLIC HIGHWAY.**

### 1.2.3 - Using the machine

It is important to ensure that in normal use, i.e. platform operation, the platform station selection key remains in the the platform position to enable control of the machine from the platform. If a problem occurs on the platform, a person present and trained in emergency/standby manoeuvres can help by putting the key in the ground control position.

Never use the machine with:

- a load greater than the nominal load,
- more people than the authorised number,
- lateral force in the platform greater than the level permitted,
- wind speed higher than the permitted level.



To avoid all risk of serious fall, operators must respect the following instructions:

- Hold the hand rails firmly when climbing onto or operating the platform.
- Wipe any traces of oil or grease off the steps, floor and hand rails.
- Wear protective clothing suited to working conditions and current local legislation, in particular when working in hazardous areas.
- Do not disable the safety system end of stroke contactors.
- Avoid contact with fixed or mobile obstacles.
- Do not increase working height by using ladders or other accessories.
- Never use the hand rails as a means of access for getting onto and off the platform (use the steps provided on the machine).
- Never climb on the hand rails when the platform is raised.
- Never drive the platform at high speed in narrow or cluttered areas.
- Never use the machine without installing the platform protective bar or closing the safety barrier.
- Never climb on the covers.



**Caution!**

**Never use the platform as a crane, goods lift or elevator. Never use the platform or tow or haul.**



To avoid risks of tipping over, operators must respect the following instructions:

- Do not disable the safety system end of stroke contactors.
- Avoid moving the steering control levers in the opposite direction, without stopping in the "O" position (to stop during a travel manoeuvre, move the manipulator lever gradually).
- Respect maximum load and maximum number of people authorised on the platform.
- Distribute the load evenly and place in the centre of the platform if possible.
- Check that the floor resists the pressure and load per wheel.
- Avoid contact with fixed or mobile obstacles.
- Do not drive the platform at high speed in narrow or cluttered areas.
- Do not drive the platform in reverse (inadequate visibility).
- Do not use the machine if the platform is cluttered.
- Do not use the machine with equipment or objects hanging from the hand rails.
- Do not use the machine with elements that may increase the wind load (e.g. panels).
- Do not perform machine maintenance operations when the machine is raised without setting up the required safety means (gantry crane, crane).
- Make daily checks and monitor proper operation during periods of use.
- Preserve the machine from any uncontrolled operation when it is not in service.

**NB:** *Do not tow the platform (it is not designed to be towed and must be transported on a trailer).*

## 1.3 - RESIDUAL RISKS



### Caution!

*The direction of travel can be reversed after a 180° turntable rotation. Take account of the colour of the arrows on the chassis compared with the direction of travel (green = forward, red = reverse)*

*Thus, moving the manipulator in the direction of the green arrow on the control panel will move the machine according to the direction indicated by the green arrow on the chassis. Similarly, moving a manipulator in the direction of the red arrow on the control panel, will move the machine in the direction of the red arrow on the chassis*



### Caution!

*If the machine has a 220 V 16A max. plug, the extension must be connected to a mains socket protected by a 30 mA differential circuit breaker.*

### 1.3.1 - Risks of jerky movements and tipping over

Risks of jerky movement and tipping over are high in the following situations:

- Sudden action on the controls.
- Overloading of the platform.
- Uneven ground (Be careful during thaw periods in winter).
- Gusts of wind.
- Contact with an obstacle on the ground or at a height.
- Working on platforms, pavements, etc.

Allow sufficient stopping distances:

- 3 meters at high speed,
- 1 meter at low speed.

Allow sufficient stopping distances: 3 metres at high speed and 1 metre at low speed.

Do not alter or neutralise any components connected in any way to the machine's safety or stability.

Do not place or fasten a load so that it overhangs the machine's parts.

Do not touch adjacent structures with the elevator arm.

### 1.3.2 - Electrical risk

Electrical risks are high in the following situations:

- Contact with a live line (check safety distances before operation near electricity lines).
- Use during storms.

### 1.3.3 - Risk of explosion or burning

The risks of explosion or burning are high in the following situations:

- Working in explosive or inflammable atmosphere.
- Filling the fuel tank near naked flames.
- Contact with the hot parts of the motor.
- Use of a machine generating hydraulic leakage.

### 1.3.4 - Risks of collision

- Risk of crushing people in the machine operation zone (when travelling or manoeuvring equipment).
- The operator must assess the risks above him before using the machine.
- Pay attention to the position of the arms during turntable rotation.
- Adapt movement speed to conditions related to the ground, traffic, slope and movement of people, or any other factor that may cause a collision.
- When driving down the ramp of a truck, ensure sufficient space is available for safe unloading.
- Check brake pad wear regularly to avoid all risk of collision.

## 1.4 - INSPECTIONS

Comply with the national regulations in force in the country of machine use.

For FRANCE: Order dated 9 June 1993 + circular DRT 93 dated 22 September 1993 which specify:

### 1.4.1 - Periodic inspections

The machine must be inspected every 6 months in order to detect any defects liable to cause an accident.

These inspections are performed by an organisation or personnel specially designated by the site manager and under his responsibility (whether or not they belong to the company) Articles R 233-5 and R 233-11 of the French Labour Code.

The results of these inspections are recorded in a safety register kept by the site manager and constantly available to the labour inspector and the site safety committee (if one exists) and the list of specially designated personnel (Article R 233-5 of the French Labour Code).

Moreover, before each use, check the following:

- the operator's manual is in the storage compartment on the platform,
- the stickers are placed according to the section concerning "Labels and their positions",
- oil level and any elements in the maintenance operation table
- look out for any damaged, incorrectly installed, modified or missing parts.

---

**NOTE :** *This register can be obtained from trade organisations, and in some cases from the OPPBTP or private prevention agencies.*

---

The designated persons must be experienced in risk prevention (Articles R 233-11 or order n° 93-41).

No member of personnel is allowed to perform any check whatsoever during machine operation (Article R 233-11 of the French Labour Code).

### 1.4.2 - Examination of machine suitability

The manager of the site where the machine is operated must ensure the machine is suitable, i.e. capable of performing the work in complete safety, and in compliance with the operating manual. Furthermore, the French order of 9 June 1993 addresses problems relative to leasing, examination of the state of conservation, checking upon operation after repairs, and test conditions (static test coefficient 1.25; dynamic test coefficient 1.1). All users must consult this order's requirements and comply with them.

### 1.4.3 - State of conservation

Detect any deterioration liable to cause hazardous situations (concerning safety devices, load limiters, tilt sensor, cylinder leaks, deformation, welds, bolt tightness, hoses, electrical connections, tyre state, excessive mechanical gaps).

---

**NOTE :** *If the machine is rented/leased, the user responsible for the machine must examine its state of conservation and suitability. He must obtain assurance from the leaser that general periodic inspections and pre-operation inspections have been performed.*

---

**1.5 - REPAIRS AND ADJUSTMENTS**

These cover major repairs, and work on or adjustments to safety systems or devices (of a mechanical, hydraulic or electrical nature).

These must be performed by personnel from or working for PINGUELY-HAULOTTE who will use only original parts.

Any modification not controlled by PINGUELY-HAULOTTE is unauthorised.

The manufacturer cannot be held responsible if non-original parts are used or if the work specified above is not performed by PINGUELY-HAULOTTE-approved personnel.

**1.6 - VERIFICATIONS WHEN RETURNING TO SERVICE**

To be performed after:

- extensive disassembly-reassembly operation,
- repair affecting the essential components of the machine,
- any accident caused by the failure of an essential component.

It is necessary to perform a suitability examination, a state of conservation examination, a static test, a dynamic test (see coefficient in paragraph (see Chap 1.4.2, page 5).



**Caution!**

**These test must be performed by a competent person.**

**1.7 - BEAUFORT SCALE**

The Beaufort Scale of wind force is accepted internationally and is used when communicating weather conditions. It consists of number 0 - 17, each representing a certain strength or velocity of wind at 10m (33 ft) above ground level in the open.

| Description of Wind | Specifications for use on land   | MPH   | m/s       |
|---------------------|--|-------|-----------|
| 0 Calm              | Calm; smoke rises vertically   | 0-1   | 0-0.2     |
| 1 Light Air         | Direction of wind shown by smoke   | 1-5   | 0.3-1.5   |
| 2 Light Breeze      | Wind felt on face; leaves rustle; ordinary vanes moved by wind                               | 6-11  | 1.6-3.3   |
| 3 Gentle Breeze     | Leaves and small twigs in constant motion; wind extends light flag                           | 12-19 | 3.4-5.4   |
| 4 Moderate Breeze   | Raises dust and loose paper; small Branches are moved  | 20-28 | 5.5-7.9   |
| 5 Fresh Breeze      | Small trees in leaf begin to sway; crested wavelets form on inland waterways                 | 29-38 | 8.0-10.7  |
| 6 Strong Breeze     | Large branches in motion; whistling heard in telephone wires; umbrellas used with difficulty | 39-49 | 10.8-13.8 |
| 7 Near Gale         | Whole trees in motion; inconvenience felt when walking against wind                          | 50-61 | 13.9-17.1 |
| 8 Gale              | Breaks twigs off trees; generally impedes progress   | 62-74 | 17.2-20.7 |
| 9 Strong Gale       | Slight structural damage occurs (chimney pots and slates removed)                            | 75-88 | 20.8-24.4 |

## 2 - PRESENTATION

Self-propelled platform, model HA15I, is designed for all kinds of overhead work, within the limits of its capabilities (Chap 2.1.1 -, page: 7) and in compliance with all safety recommendations specific to the equipment and places of use.

The main control panel is in the platform.

The turntable control panel is an emergency or rescue station.

### 2.1 - TECHNICAL CHARACTERISTICS

#### 2.1.1 - HA15I technical characteristics

| Description  | HA15I  |
|--|--|
| Load (indoor use)  | 250 kg   |
| Maximum lateral force  | 40 daN   |
| Working height   | 15 m   |
| Platform height  | 12.9 m   |
| Maximum range  | 7.7 m  |
| Turret rotation  | 360°   |
| platform rotation  | ± 90°  |
| Tilt   | 3°   |
| Platform dimensions  | 1140 x 700 + 60 mm.  |
| Maximum ramp   | 25 %   |
| Lifting speed  | 0.75 km/h  |
| High travel speed  | 4.1 km/h   |
| Batteries  | 48V - 360A/h en 2 bacs<br>375 A/h with Fulmen  |
| Floor clearance  | 130 mm   |
| Tyres  | 700x12   |
| Turning radius   | 3.3 m  |
| Boom extension   | - 13° + 75°  |
| Telescoping (travel)   | 2550 mm  |
| Max. wind speed in operation   | 45 km/h  |
| Max. pressure on the ground:<br>- hard surface (concrete)<br>- soft surface (beaten earth)   | 11.1 daN/cm <sup>2</sup><br>7.7 daN/cm <sup>2</sup>                                  |
| Max. force on one wheel  | 3070 kg  |
| Movement times with one person in the platform:<br>• Telescoping: out / in (approx.)<br>• Arm lifting: up / down (approx.)<br>• Boom lifting: up / down (approx.)<br>• Slewing (approx.) | 36 / 20 s<br>42 / 39 s<br>27 / 18 s<br>68 s  |
| Motor: make (standard)<br>Voltage<br>Power<br>Consumption  | LEROY SOMER<br>24 V serial mounted<br>2 kW<br>80 A on horizontal ground - 300 A max. |
| Acoustic pressure level at operating station,  | 72 dB(A)   |
| Vibrations at foot level   | < 0.5 m/s <sup>2</sup>   |
| Vibrations at hand level   | < 2.5 m/s <sup>2</sup>   |
| Main hydraulic pump : capacity   | 5.5 cm <sup>3</sup> /rev   |
| Oil tank capacity  | 30 litres  |

| Description  | HA15I  |
|--|--|
| Rated hydraulic pressure *<br>max. steering pressure<br>max. slewing pressure<br>max. telescope out pressure<br>max. boom lifting pressure<br>max. arm lifting pressure<br>max. brake release pressure | 220 bar<br>75 bar<br>220 bar<br>220 bar<br>220 bar |
| Wheel nut tightening torque  | 190 Nm   |
| Slew ring screw tightening torque (grey Dacromet screw)  | 90 Nm  |
| Slew ring screw tightening torque (black non-Dacromet screw)   | 135 Nm   |
| Weight   | 6600 kg  |

### 2.1.2 - HA15I dimensions

HA15I dimensions

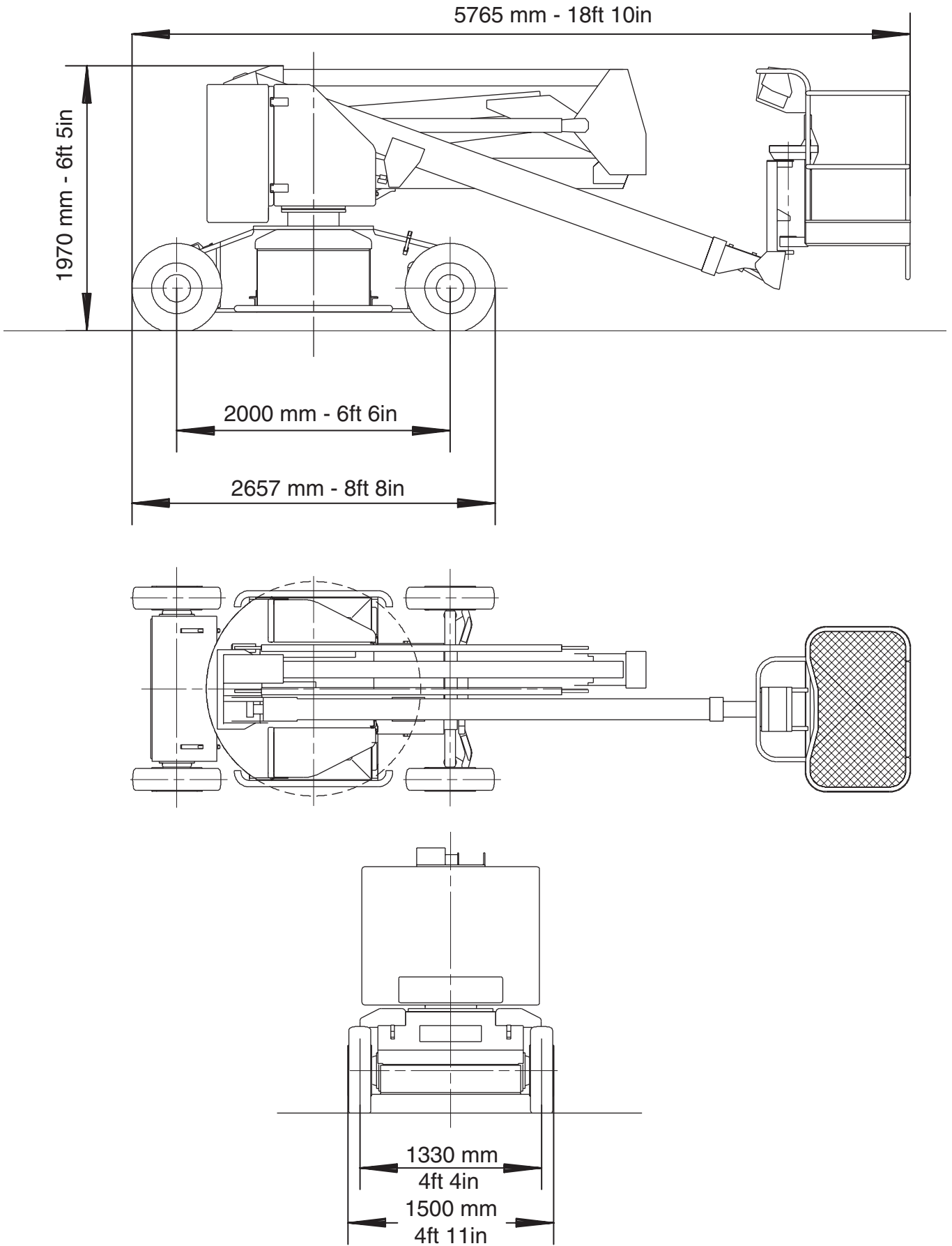

**2.2 - TIGHTENING TORQUE**

**2.2.1 - Large thread screw tightening torque values**

| <i>Nominal diameter</i> | <i>Tightening torque in N.M</i> |              |              |
|-------------------------|---------------------------------|--------------|--------------|
|                         | <b>8.8</b>                      | <b>10.9</b>  | <b>12.9</b>  |
| <b>M 6*1</b>            | 9 to 11                         | 13 to 14     | 15 to 17     |
| <b>M 7*1</b>            | 15 to 19                        | 21 to 24     | 26 to 28     |
| <b>M 8*1.25</b>         | 22 to 27                        | 31 to 34     | 37 to 41     |
| <b>M 10*1.5</b>         | 43 to 45                        | 61 to 67     | 73 to 81     |
| <b>M 12*1.75</b>        | 75 to 94                        | 110 to 120   | 130 to 140   |
| <b>M 14*2</b>           | 120 to 150                      | 170 to 190   | 200 to 220   |
| <b>M 16*2</b>           | 190 to 230                      | 260 to 290   | 320 to 350   |
| <b>M 18*2.5</b>         | 260 to 320                      | 360 to 400   | 440 to 480   |
| <b>M 20*2.5</b>         | 370 to 450                      | 520 to 570   | 620 to 680   |
| <b>M 22*2.5</b>         | 500 to 620                      | 700 to 770   | 840 to 930   |
| <b>M 24.3*3</b>         | 630 to 790                      | 890 to 990   | 1070 to 1180 |
| <b>M 27*3</b>           | 930 to 1150                     | 1300 to 1400 | 1560 to 1730 |
| <b>M 30*3.5</b>         | 1260 to 1570                    | 1770 to 1960 | 2200 to 2350 |

**2.2.2 - Small thread screw tightening torque values**

| <i>Nominal diameter</i> | <i>Tightening torque in N.M</i> |              |              |
|-------------------------|---------------------------------|--------------|--------------|
|                         | <b>8.8</b>                      | <b>10.9</b>  | <b>12.9</b>  |
| <b>M 8*1</b>            | 24 to 29                        | 33 to 37     | 40 to 44     |
| <b>M 10*1.25</b>        | 46 to 57                        | 64 to 71     | 77 to 85     |
| <b>M 12*1.25</b>        | 83 to 100                       | 120 to 130   | 140 to 150   |
| <b>M 14*1.5</b>         | 130 to 160                      | 180 to 200   | 220 to 240   |
| <b>M 16*1.5</b>         | 200 to 250                      | 280 to 310   | 340 to 370   |
| <b>M 18*1.5</b>         | 290 to 360                      | 410 to 450   | 490 to 540   |
| <b>M 20*1.5</b>         | 410 to 510                      | 570 to 630   | 690 to 760   |
| <b>M 22*1.5</b>         | 550 to 680                      | 780 to 870   | 920 to 1000  |
| <b>M 24*1.5</b>         | 690 to 860                      | 970 to 1070  | 1160 to 1290 |
| <b>M 27*2</b>           | 1000 to 1300                    | 1400 to 1560 | 1690 to 1880 |
| <b>M 30*2</b>           | 1400 to 1700                    | 1960 to 2180 | 2350 to 2610 |

**2.2.3 - Wheel tightening torque values**

| <i>Tightening torque in N.M</i> |                        |
|---------------------------------|------------------------|
| <i>Steering wheel nut</i>       | <i>Drive wheel nut</i> |
| 19 daNm                         | 19 daNm                |

**2.2.4 - Hydraulic hose tightening torque values**

| <i>Description</i> | <i>Torque (Nm)</i> |
|--------------------|--------------------|
| 1/4"               | 15 ±1              |
| 3/8"               | 28 ±2              |
| 1/2"               | 62 ±2              |
| 5/8"               | 80 ±5              |
| 3/4"               | 110 ±5             |
| 1" 1/4             | 225 ±5             |
| 1" 1/2             | 270 ±15            |

**2.2.5 - TPressure table (bar)**

|       | Steering | Brake release | Slewing | Arm lifting | Boom lifting | Telescoping |
|-------|----------|---------------|---------|-------------|--------------|-------------|
| HA15I | 220      | 220           | 75      | 220         | 220          | 220         |

**2.2.6 - Table of adjustment times**

| <i><b>Movement</b></i>             | <i><b>Control</b></i> | <i><b>Movement duration</b></i>          |
|------------------------------------|-----------------------|--|
| <b>deceleration</b>                | From the basket       | <b>1 m ± 20 cm</b>                       |
| <b>FOR and REV travel</b>          | From the basket       | <b>between 20" and 24 " by 20 m</b>      |
| <b>Boom lifting</b>                | From the basket       | <b>between 24"and 26"</b>                |
| <b>Boom lowering</b>               | From the basket       | <b>between 16" and 18"</b>               |
| <b>Arm lifting</b>                 | From the basket       | <b>between 40" and 42"</b>               |
| <b>Arm lowering</b>                | From the basket       | <b>between 25" and 27"</b>               |
| <b>Telescope out</b>               | From the basket       | <b>between 34" and 36"</b>               |
| <b>Telescope in</b>                | From the basket       | <b>between 16" and 18"</b>               |
| <b>Rotation</b>                    | From the basket       | <b>between 1'10" and 1'20" all round</b> |
| <b>Increase compensation speed</b> | From the basket       | <b>between 27" and 31"</b>               |
| <b>Decrease compensation speed</b> | From the basket       | <b>between 30" and 34"</b>               |

## 3 - SAFETY SYSTEMS

### 3.1 - MACHINE ELEMENTS

(see wiring diagrams)

#### 3.1.1 - Turntable box and chopper plate

|       |  |                                    |
|-------|--|------------------------------------|
| KA 1  | Tilt break relay and accu capacity indicator | Arm lifting (up)                   |
| KA 2  | Tilt break relay and accu capacity indicator | Boom lifting (up)                  |
| KA 3  | Tilt break relay and accu capacity indicator | Telescope out                      |
| KA 4  | Low speed forced control                     | Downhill > 3°                      |
| KA 5  | Tilt break relay                             | Travel                             |
| KA 6  | Horn control relay                           |                                    |
| KA 7  | Brake release authorisation relay            |                                    |
| KA 8  | Steering control relay                       |                                    |
| KA 9  | Steering control relay                       |                                    |
| KA 10 | Electropump control relay                    | Steering mode                      |
| KA 11 | Speed limitation relay                       | Manual compensation                |
| KA 12 | Speed limitation relay                       | Turntable slewing                  |
| KA 13 | Electropump control relay                    | Travel mode                        |
| KA 14 | Chopper mode selection relay                 | Movements or travel                |
| KA 15 | Brake release control relay                  |                                    |
| KT 1  | Brake release time delayed relay             | Time delay after stop              |
| KM 1  | Line contactor                               | Power on                           |
| KM 2  | On/off pump contact                          | Steering                           |
| KM 3  | Variable pump contact                        | Movements                          |
| KM 4  | Travel contact                               | FOR - REV on                       |
| QF 1  | 5 A circuit breaker                          | Main protection                    |
| QF 2  | 5 A circuit breaker                          | Tilt protection                    |
| QF 3  | 5 A circuit breaker                          | Horn protection                    |
| QF 4  | 10 A circuit breaker                         | Option protection                  |
| FU 1  | 7 A fuse                                     | Contact protection                 |
| FU 2  | 30 A fuse                                    | Control circuit protection         |
| FU 3  | 400 A fuse                                   | Electric motor protection          |
| FU 4  | 2 A fuse                                     | Accu capacity indicator protection |
| PV    | Battery charge controller                    | Battery protection                 |

#### 3.1.2 - Safety contacts

|      |                           |   |
|------|---------------------------|---|
| SB 5 | "Failsafe" pedal          |   |
| SQ 1 | 3% tilt detection box     | Disables travel and lifting movements if slope = 3° |
| SQ 2 | Tilt reset                | If machine folded.                                  |
| SQ 3 | Overload break + alarm    |   |
| SQ 4 | Overload break + alarm    |   |
| SQ 5 | High speed authorisation  | If machine folded                                   |
| SQ 6 | Travel break at 8m option |   |
| SQ 7 | Travel break at 8m option |   |
| SQ 8 | Travel break at 8m option |   |



# 4 - WIRING DIAGRAMS

## 4.1 - FOLIO 1

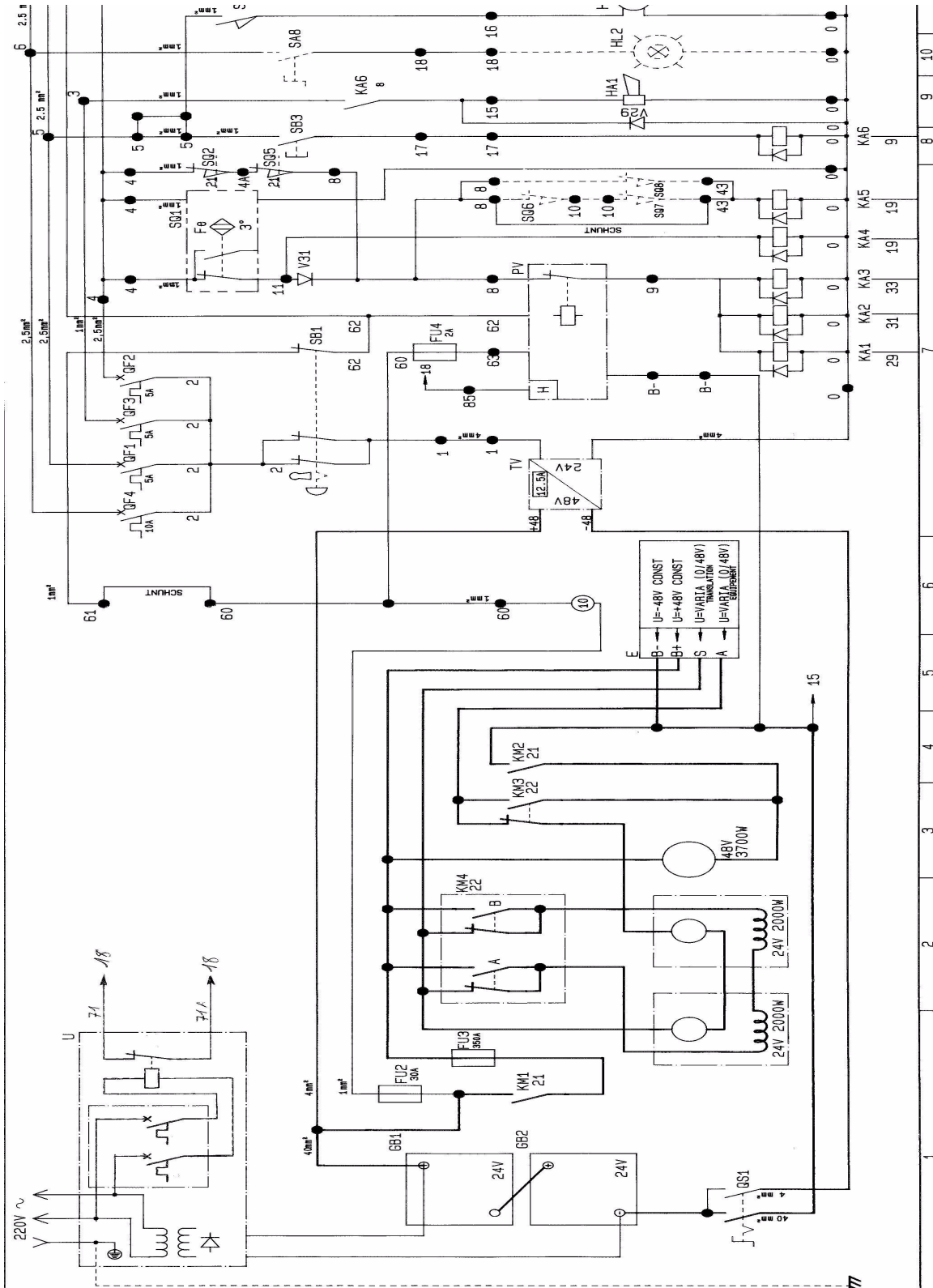

4.2- FOLIO 2

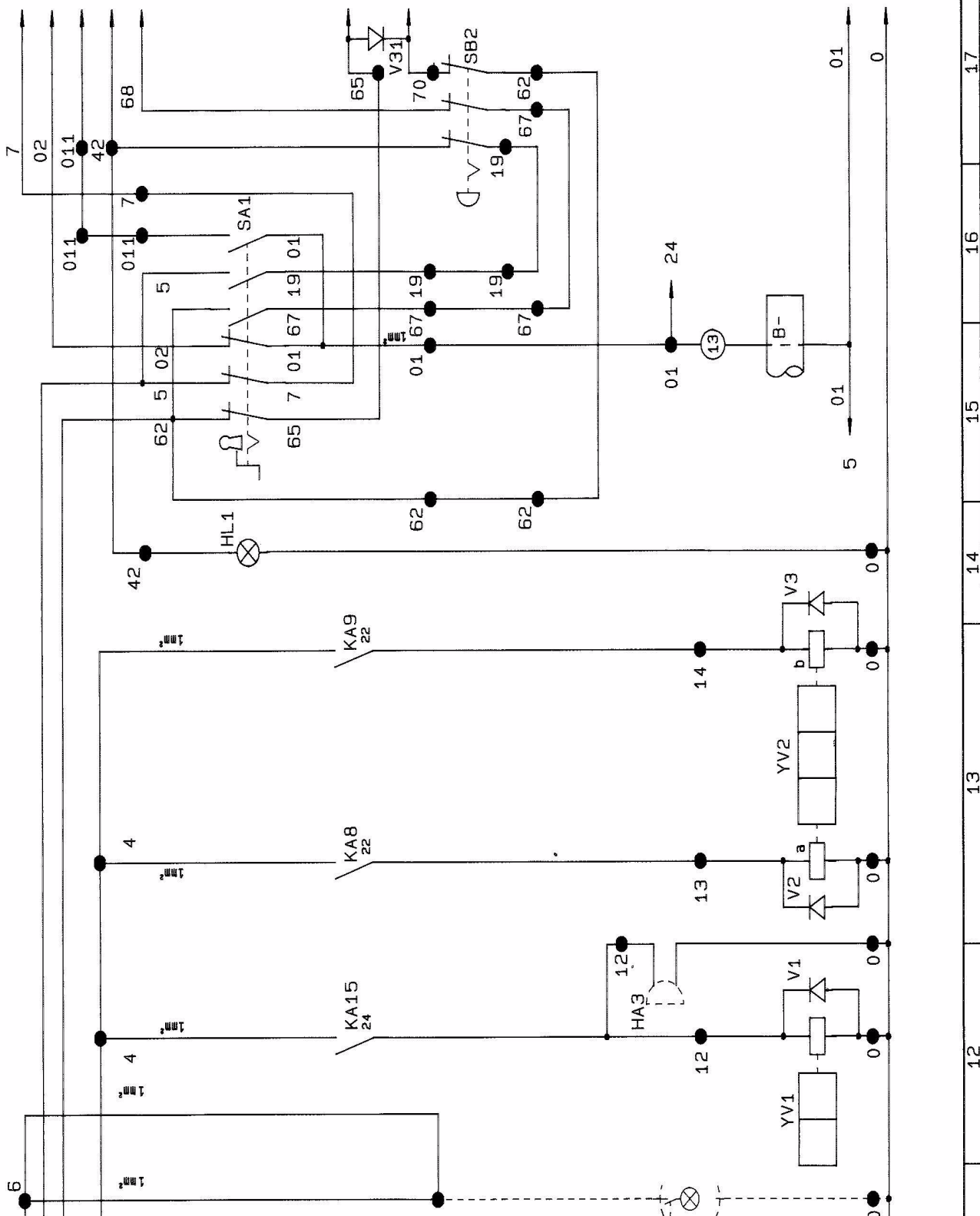

4.3 - FOLIO 3

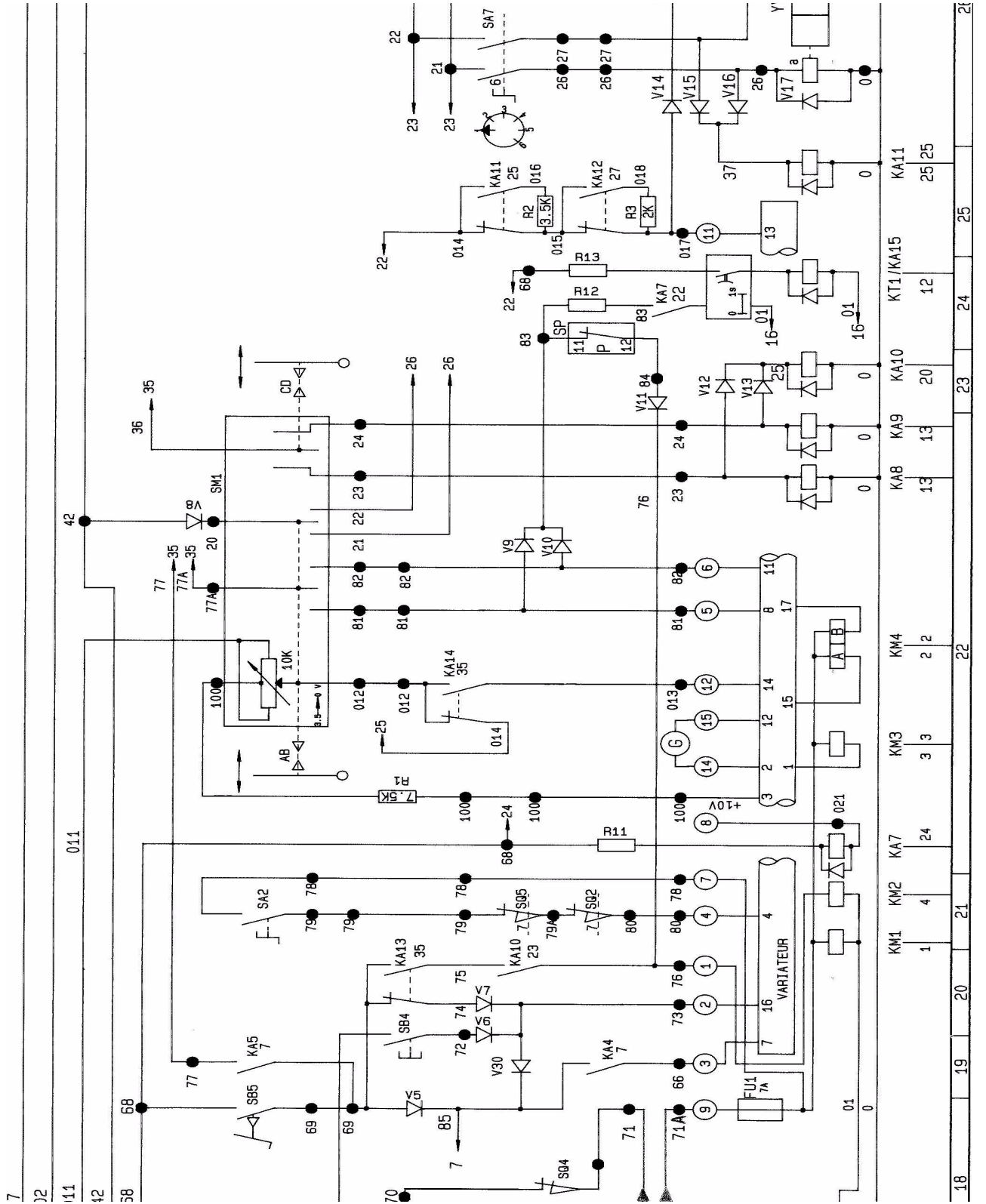

4.4 - FOLIO 4

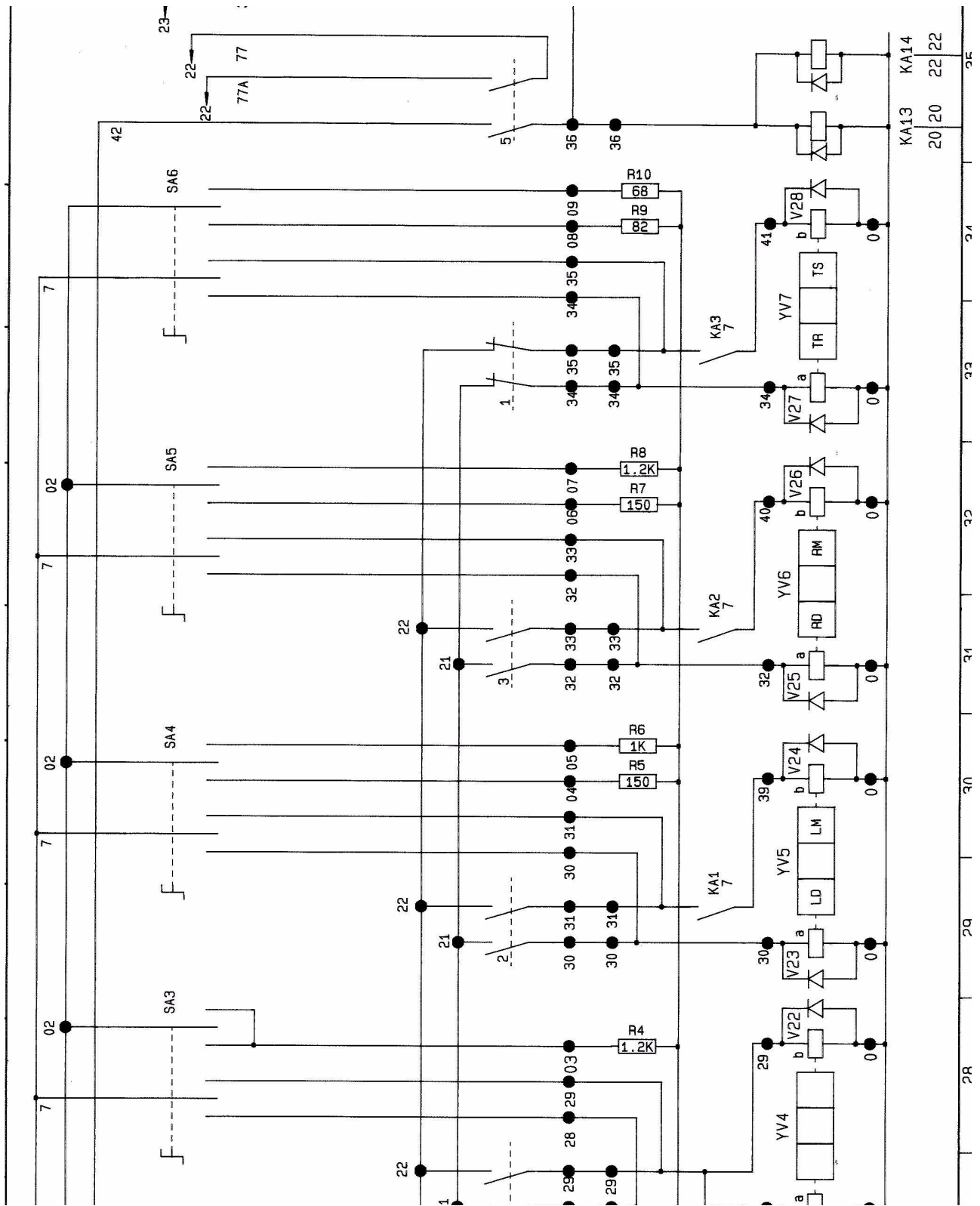

# 5 - HYDRAULIC DIAGRAMS

## 5.1 - HYDRAULIC DIAGRAM

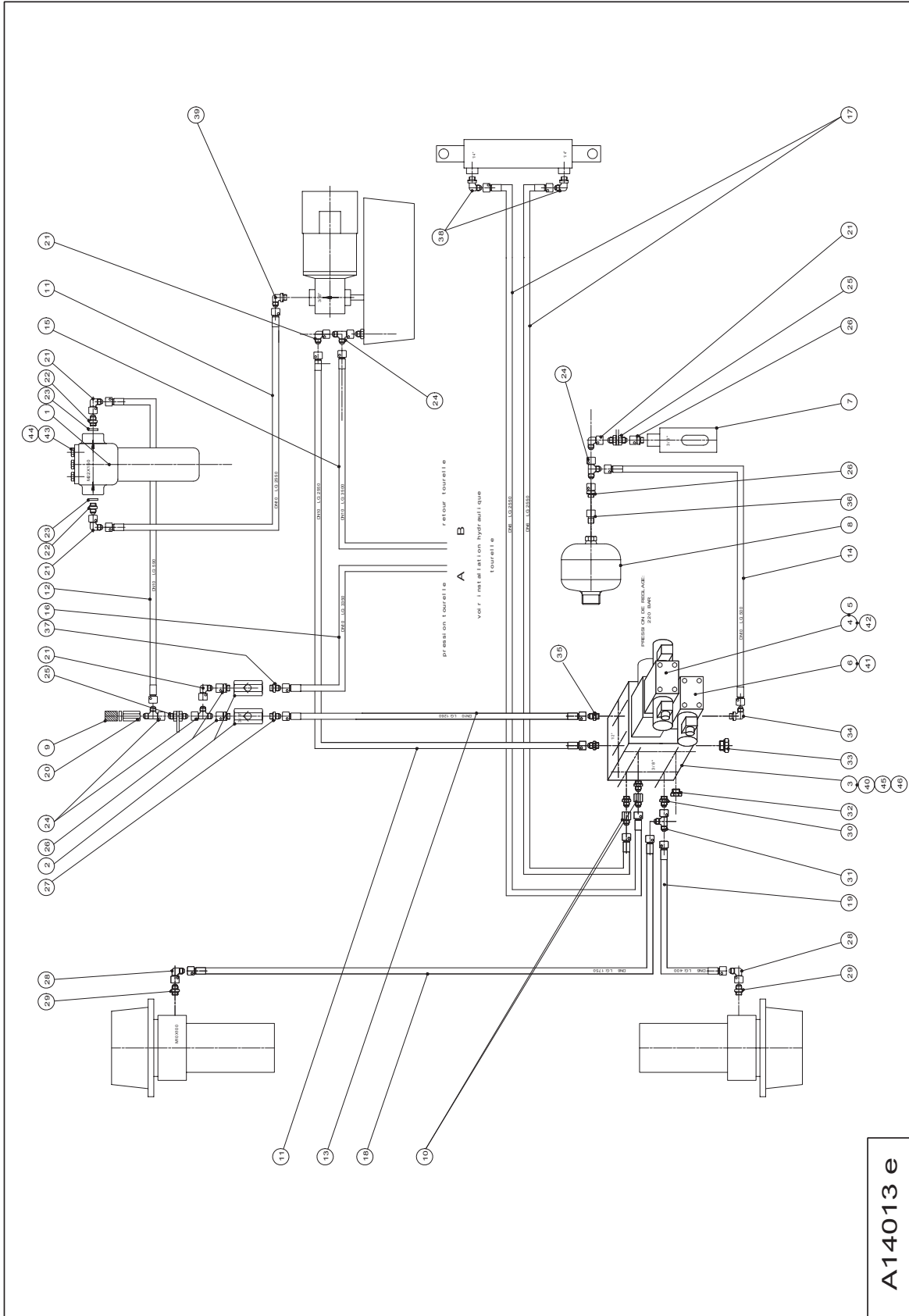

5.2 - HYDRAULIC DIAGRAM

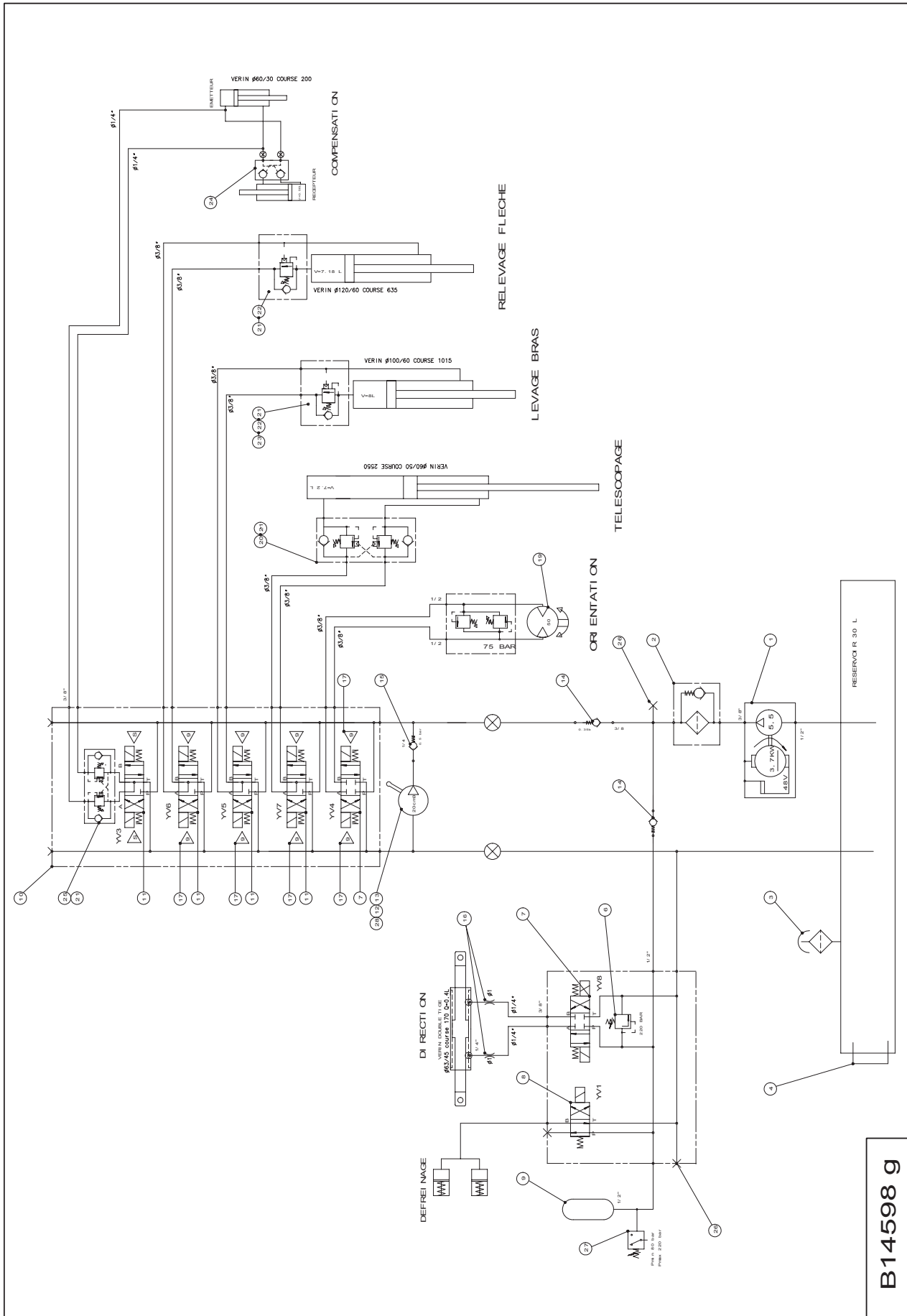

---

## 6 - MAINTENANCE

---

### 6.1 - GENERAL RECOMMENDATIONS

The servicing operations in this manual are specified for normal operating conditions.

In difficult conditions: extreme temperatures, high humidity, polluted atmosphere, high altitude, etc. some operations must be carried out more frequently and specific precautions must be taken: consult the motor manufacturer's manual and contact your local PINGUELY-HAULOTTE agent for more details.

Only approved and skilled personnel may intervene on the machine and must comply with safety instructions concerning personal and environment protection.



#### **Caution!**

- Do not use the machine as a welding earth.**
  - Do not weld without disconnecting the (+) and (-) terminals of the batteries.**
  - Do not jump start other vehicles.**
- 

### 6.2 - SPECIFIC RECOMMENDATIONS

Before any maintenance intervention on the platform, make it clear on the turntable and platform control panels, that the machine is being serviced. Limit access to the platform to intervention personnel only.

#### 6.2.1 - Specific tools

Personnel must be familiar with the use of specific tools implemented (measuring devices, torque wrench systems, lifting apparatus, etc.) and comply with the operating limits specified in the documents supplied with such tools.

Incorrect use of a tool (incorrect adjustment due to a measurement error) may cause premature ageing of the platform (or more seriously, an accident). PINGUELY-HAULOTTE cannot be held responsible for such incidents.

#### 6.2.2 - Replacing a part

Before replacing a part, the machine must be put into the maintenance configuration (see relevant section) and the electric power cut off (see relevant section).

All distributing valves are "open centre": breaking the electric circuit causes pressure to fall in the hydraulic circuits as far as the non-return valves flanged on the cylinders. A part can therefore be replaced safely if the procedures described in the maintenance sheets are followed (unscrew hydraulic connectors slowly to eliminate residual pressure).

To preserve safety system integrity and the technical characteristics of the platform, it is essential to use original parts and comply with the initial adjustment values and tightening torque values (see relevant section).

#### 6.2.3 - Locating the breakdown

Some checks require the platform power to be on. In this case, personnel must:

- ensure that measurement tools used are properly insulated,
- not touch live parts,
- not carry any metal objects that may damage live parts (e.g. dropping a spanner during an intervention on the batteries).

**6.2.4 - Protecting the environment**

To ensure environmental protection, an oil collection tank must be used during any intervention requiring drainage of hydraulic oil or if there is a risk of a hydraulic leak.

**6.3 - MAINTENANCE SYSTEM**

Photo 1

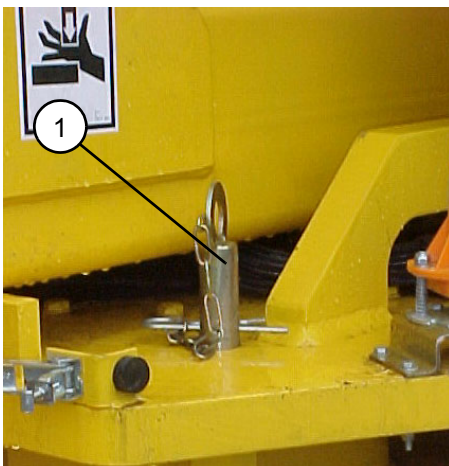

**Instructions:**

Putting the machine into the maintenance configuration:

- Position the platform on a firm, horizontal surface.
- If possible, fold the machine completely. Otherwise, for certain specific operations, put the various components into slings.
- Put the turntable rotation blocking pin into place (ref 1, Photo 1, page 22).

Putting the machine back into the operational configuration:

- Remove the blocking pin (ref 1, Photo 1, page 22).

**6.4 - ELECTRIC POWER SUPPLY**

Photo 2

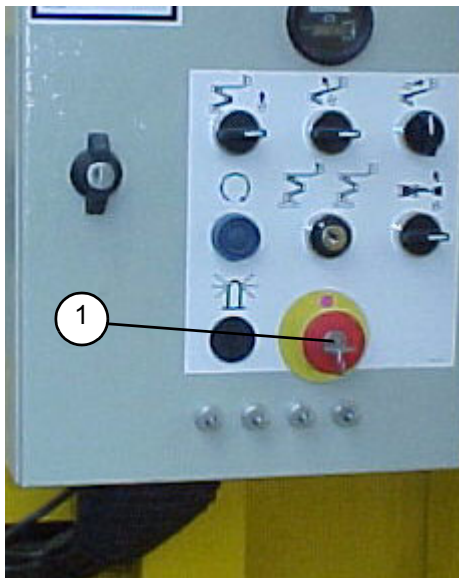

**Instructions:**

Switching off the electric power supply:

Press the turntable emergency stop (rep 1, Photo 2, page 22).







Switching the electric power back on again:

Reset the emergency stop (rep 1, Photo 2, page 22).

**6.5 - MAINTENANCE PLAN**

The plan (see next page) indicates the frequencies, servicing points (device) and ingredients to be used.

- The mark in the symbol shows the servicing point according to frequency.
- The symbol represents the consumable to be used (or the operation to be carried out).

| INGREDIENT                        | SPECIFICATION                 | SYMBOL  | Lubricants used by HAULOTTE | ELF                       | TOTAL               |
|-----------------------------------|-------------------------------|---|-----------------------------|---------------------------|---------------------|
| Gearbox oil                       | <b>SAE 90</b>                 |    | <b>ESSOEP 80 W 90</b>       | <b>TRANSELFEP 80 W 90</b> | <b>TM 80 W/90</b>   |
| Hydraulic oil                     | <b>AFNOR 48 602ISO V G 46</b> |    | <b>BPSHF ZS 46</b>          | <b>HYDRELFDS 46</b>       | <b>EQUIVISZS 46</b> |
| High pressure lithium grease      | <b>ISO - XM - 2</b>           |    |                             | <b>CARDREXA-DC 1</b>      |                     |
| Leadfree grease                   | <b>Grade 2 ou 3</b>           |   | <b>ESSOGP GREASE</b>        | <b>MULTIMOTIVE 2</b>      | <b>MULTIS EP 2</b>  |
| Replacement or specific operation |                               |  |                             |                           |                     |
| Lithium grease                    | <b>ENS / EP 700</b>           |  |                             | <b>EPEXA2</b>             |                     |

6.5.1 - Maintenance plan

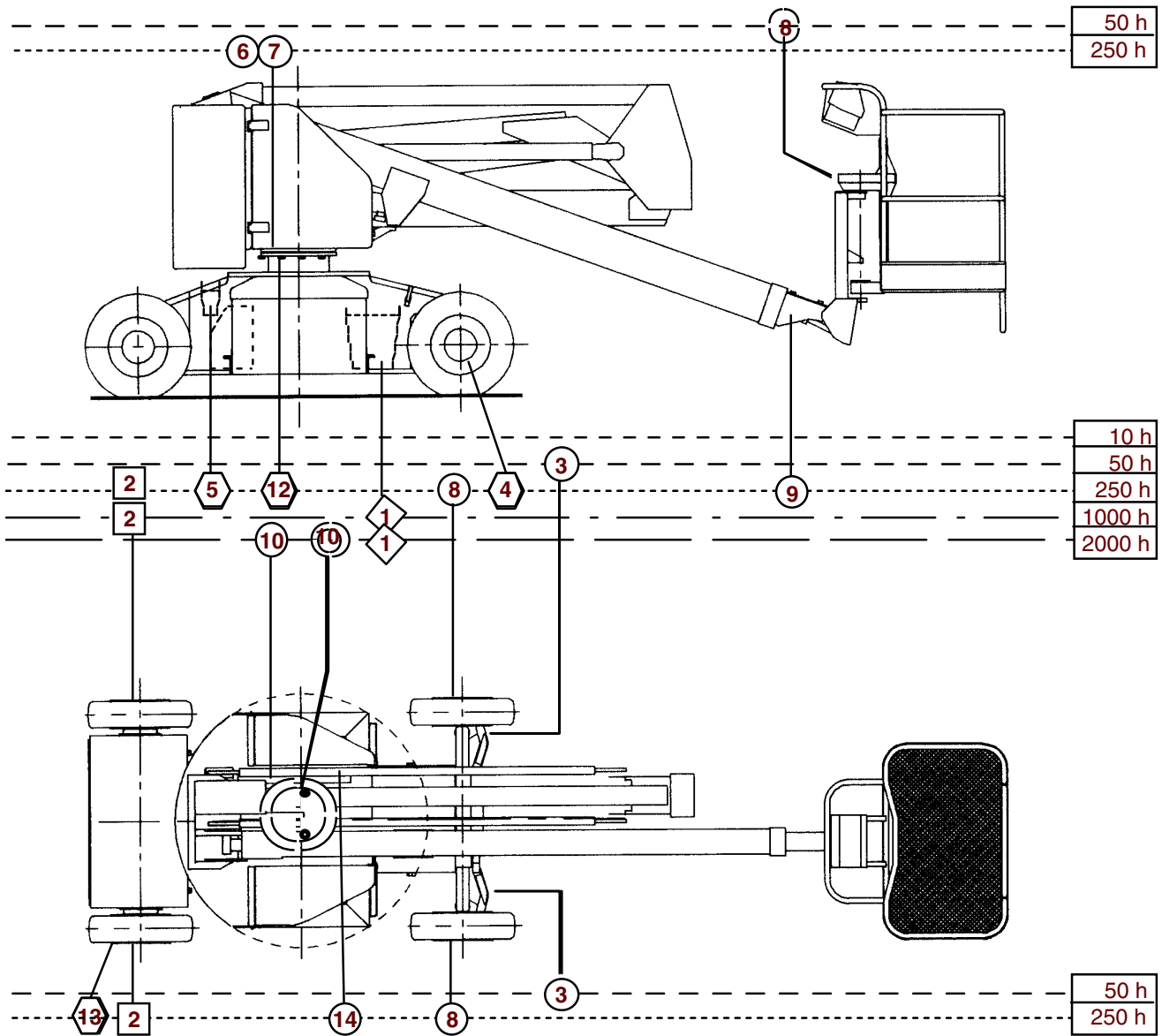

**6.6 - OPERATIONS**

| FREQUENCY                                   | OPERATION  | REF   |
|---|--|---|
| Every day or before each start of operation | <ul style="list-style-type: none"> <li>• Check               <ul style="list-style-type: none"> <li>- hydraulic tank level</li> <li>- electrolyte level in the batteries</li> <li>- battery charge using the indicator</li> </ul> </li> </ul>  | ch. 4.2.3<br>ch. 4.2.3<br>ch. 4.6   |
| Every 50 hours                              | <ul style="list-style-type: none"> <li>• Grease:               <ul style="list-style-type: none"> <li>- wheel pivot pins: 2 x 2 points</li> <li>- turntable rotation blocking pin</li> </ul> </li> <li>Platform rotation endless screw and wheel torque</li> <li>CAUTION: after first 50 hours:               <ul style="list-style-type: none"> <li>• Replace the hydraulic filter cartridge (see 250 hour frequency)</li> <li>• Change the drive wheel reducers (see 1000 hour frequency)</li> <li>• Check tightness:                   <ul style="list-style-type: none"> <li>- of slew ring bolts (see 250 hour frequency)</li> <li>- of slew ring screws (see 250 hour frequency)</li> <li>- of wheel nuts (see 250 hour frequency)</li> <li>- tightness of motor-chopper electric connections</li> </ul> </li> </ul> </li> </ul>   | plan ref. 3<br>plan ref. 14<br>plan ref. .8<br><br>ch. 5.3.1<br><br>ch. 5.3.2   |
| Every 250 hours                             | Replace the hydraulic filter cartridge <ul style="list-style-type: none"> <li>• Grease:               <ul style="list-style-type: none"> <li>- steering wheel bearings (remove the cap)</li> <li>- slew ring bearing path (rotate during the operation) 2 points</li> <li>- friction parts of the telescope (spatula)</li> <li>- teeth of the slew ring with a brush</li> <li>- battery terminals</li> </ul> </li> <li>• Check the level of the drive wheel reducers (ch. 5.3.2)</li> <li>• Check:               <ul style="list-style-type: none"> <li>- battery charger connection</li> <li>- tightness of slew ring screws and nuts:                   <ul style="list-style-type: none"> <li>DACROMET (grey screw) = 90Nm</li> <li>Non DACROMET (black screw) = 135Nm</li> </ul> </li> <li>- tightness of steering wheel nuts (torque 19 DaNm)</li> <li>- tightness of drive wheel nuts (torque 19 daNm)</li> <li>- tightness of motor electric connections and</li> <li>- tightness of battery terminals</li> </ul> </li> </ul> | plan ref.5<br><br>plan ref.8<br>plan ref.6<br><br>plan ref.9<br>plan ref.7<br>ch. 4.8<br>plan ref.2<br><br>ch. 4.7<br>plan ref.12<br><br>plan ref.4<br><br>plan ref.13<br><br>ch. 4.8 |
| Every 1000 hours                            | <ul style="list-style-type: none"> <li>• Oil change:               <ul style="list-style-type: none"> <li>- hydraulic oil tank (capacity 30 l) ch. 5.3.3</li> <li>- drive wheel reducers (capacity 0.2 l) ch. 5.3.2</li> </ul> </li> </ul>   | drawing ref.1<br>drawing ref.2  |
| Every 2000 hours                            | <ul style="list-style-type: none"> <li>• Empty the tank and the whole hydraulic oil circuit (5.3.3)</li> <li>• Grease the rotation reducer 1 + 1 point</li> </ul>  | drawing ref.1<br>drawing ref.10   |

**IMPORTANT:**

- For filling and greasing operations, only use the lubricants recommended in the table (Chap : 7.5.1 -, page 23)
- Collect drained oil to avoid pollution of the environment.

**6.7 - PRESENCE OF LABELS**

Check that the labels and plates alerting personnel to the various dangers related to machine operation are in good condition.

Labels give operators information on how to use and maintain the machine.

An illegible label may result in incorrect or dangerous use of the machine.

**Instructions:**

Check that the labels are in place:

Check that all the labels mentioned below are legible and in the right place.  
Replace if necessary (extra copies can be provided on request)

### 6.7.1 - Label positions

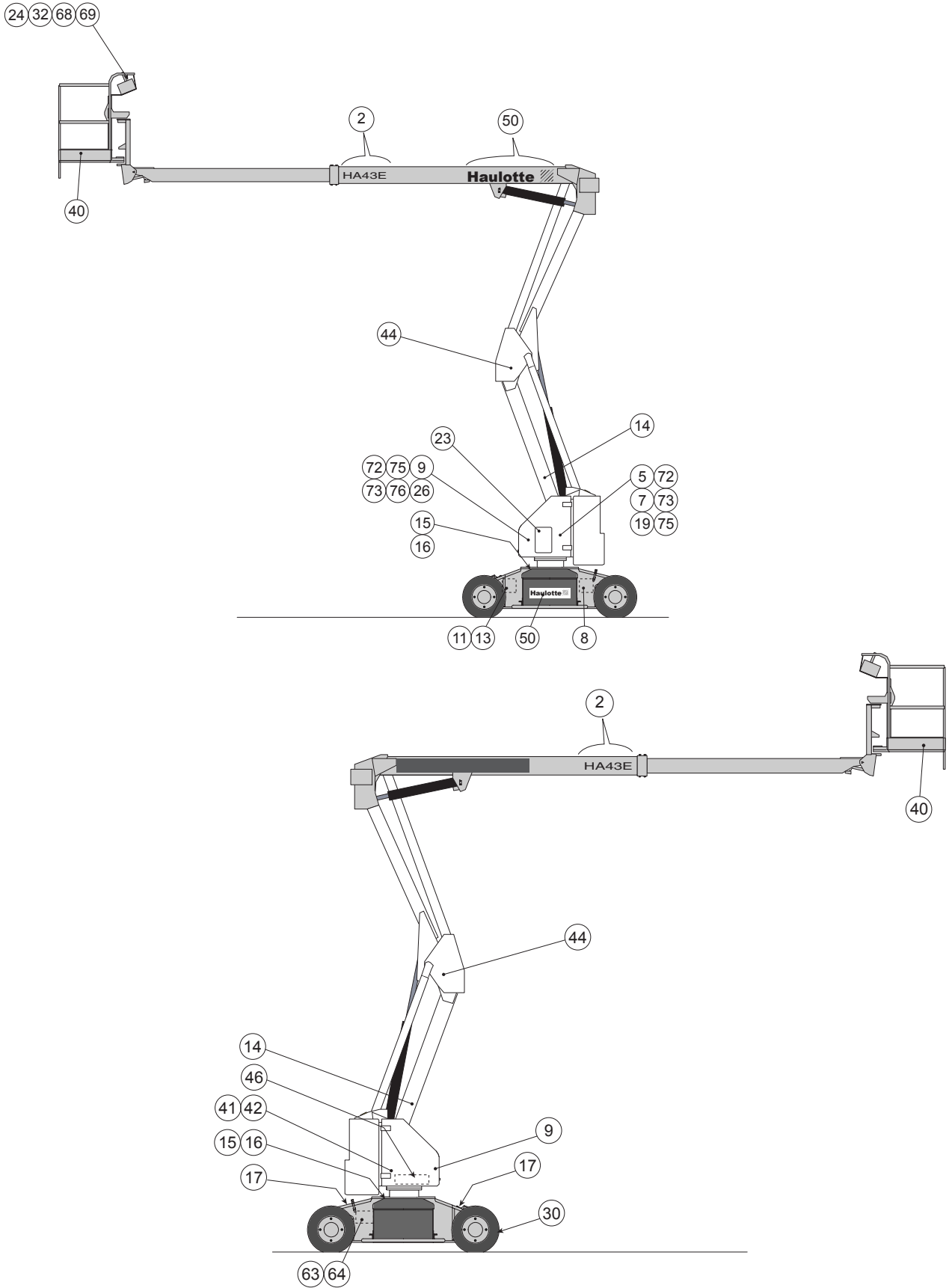

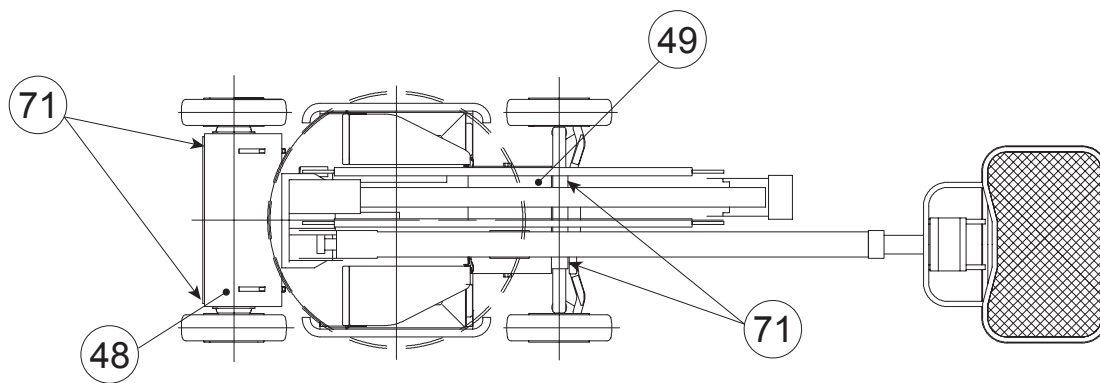
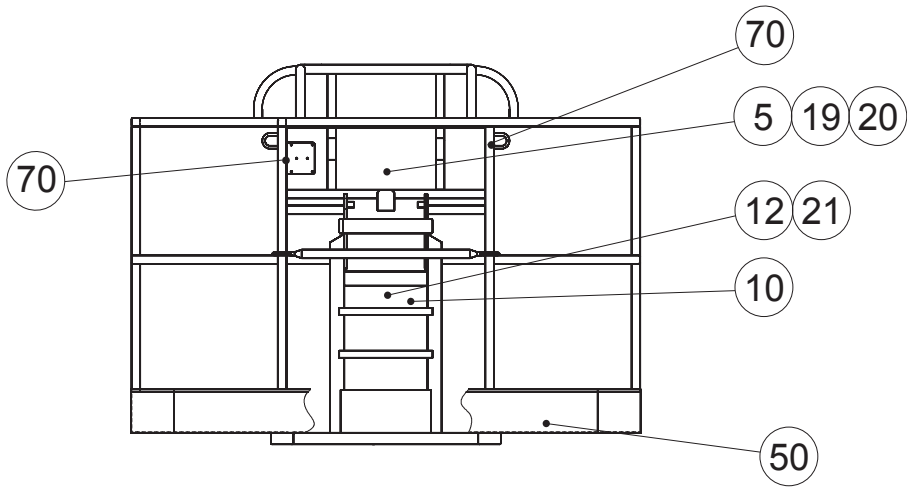

**6.8 - DECALLS**

| Index | Part No.   | Decal description                | Qty |
|-------|------------|----------------------------------|-----|
| 2     | 3078138320 | Label                            | 2   |
| 5     | 3078143990 | « Floor height... » label        | 2   |
| 7     | 3078143450 | « Operating instructions » label | 1   |
| 8     | 3078143240 | Manufacturer's name plate        | 1   |
| 9     | 3078143550 | « Do not park » park             | 1   |
| 10    | 3078143490 | « Electrocution » label          | 1   |
| 11    | 3078143520 | « Hydraulic oil » label          | 1   |
| 12    | 3078145070 | « Direction of travel » label    | 1   |
| 13    | 3078143590 | « Top oil level » label          | 1   |
| 14    | 3078143620 | « Hand crushing » label          | 2   |
| 15    | 3078143510 | « Battery servicing » label      | 1   |
| 16    | 3078143610 | « Wearing of clothes » label     | 1   |
| 17    | 3078143640 | Do not stand label               | 2   |
| 19    | 3078143600 | « Welding earth » label          | 2   |
| 20    | 3078143540 | « 220 V socket » label           | 1   |
| 21    | 3078143680 | « Read manual » label            | 1   |
| 25    | 2421803570 | Rivet                            | 4   |
| 26    | 3078143560 | ... forbidden label              | 1   |
| 27    | 2420312350 | Operator's manual                | 1   |
| 28    | 2420312390 | Spare parts catalogue            | 1   |
| 30    | 2420505950 | Warranty activation label        | 1   |
| 32    | 3078143970 | Do not go down... label          | 1   |
| 41    | 3078143570 | « Lubrication » label            | 1   |
| 42    | 3078143530 | « ... Remove pin » label         | 2   |
| 43    | 3078138330 | Logo                             | 2   |
| 44    | 3078143630 | « Body crushing » label          | 2   |
| 46    | 3078146660 | Hand pump                        | 1   |
| 48    | 3078137440 | Green arrow                      | 1   |
| 49    | 3078137430 | Red arrow                        | 1   |
| 50    | 1250127590 | « HAULOTTE » label               | 3   |
| 63    | 3078142000 | Label                            | 1   |
| 64    | 3078142010 | Label                            | 1   |
| 68    | 3078137450 | Label (red circle)               | 1   |
| 69    | 3078137460 | Label (green circle)             | 2   |

---

## 7 - PREVENTIVE MAINTENANCE SHEETS

---

List of preventive maintenance sheets:

| <i>Sheet no.</i> | <i>Description</i>                             |
|------------------|--|
| FICHE P005       | Checking - filling the hydraulic oil tank      |
| FICHE P006       | Replacing the hydraulic filter cartridge       |
| FICHE P007       | Checking - changing the oil of a wheel reducer |
| FICHE P010       | Checking - servicing the traction batteries    |



|            |  |           |
|------------|--|-----------|
| Sheet P005 | PREVENTIVE MAINTENANCE SHEET                 | Folio 1/1 |
|            | CHECKING / FILLING<br>THE HYDRAULIC OIL TANK |           |

**1 - Preliminary operations**

- Put the machine in the maintenance configuration (see corresponding paragraph).
- Switch off electric power (see corresponding paragraph).

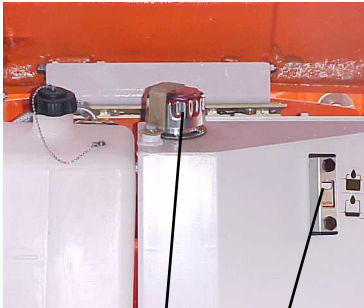

HA16/18PX - HA46/51JRT

**2 - Checking - filling the hydraulic oil tank**

*NB: This operation must be carried out when the oil is cold, i.e. before starting the machine.*

- Check that the level of oil (1) in the tank is between the high and low levels when cold.
- Top up if necessary, by filling via the cap (2).

*NB: Only use the oil recommended by the manufacturer.*

- Put the machine back into the operational configuration.

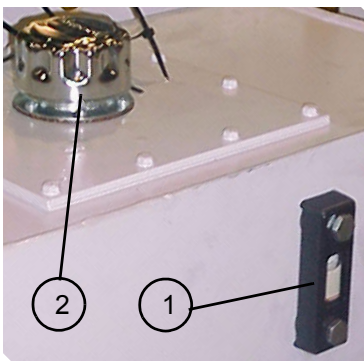

HA16/18PX New Design  
HA46/51JRT New Design

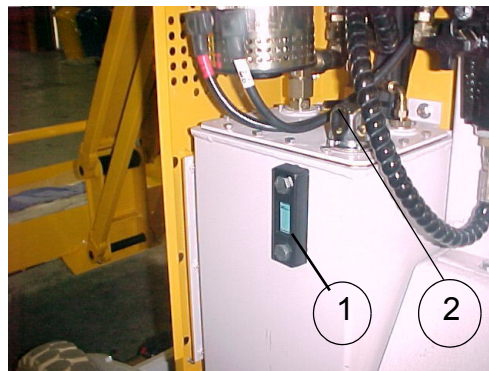

Star 22 J / Star 8

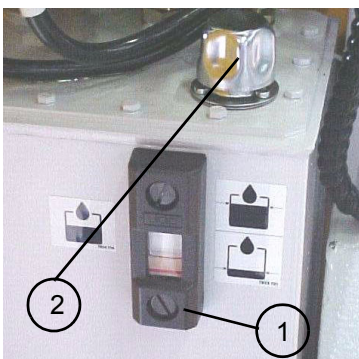

|  |                              |  |
|--|------------------------------|--|
|  | PREVENTIVE MAINTENANCE SHEET |  |
|  |                              |  |

|            |   |           |
|------------|---|-----------|
| Sheet P006 | PREVENTIVE MAINTENANCE SHEET            | Folio 1/1 |
|            | CHANGING THE HYDRAULIC FILTER CARTRIDGE |           |

 **Caution!**  
**Use a container to collect oil to prevent pollution of the environment.**

**1 - Preliminary operations**

- Put the machine in the maintenance configuration (see corresponding paragraph).
- Switch off electric power (see corresponding paragraph).

**2 - Replacing the hydraulic filter cartridge**

*NB: The filter has a clogging indicator. Clogging should be checked when the machine is hot, otherwise, the indicator may be visible due to the viscosity of the cold oil.*

- Change the cartridge (1) if the clogging indicator appears (2).
- Unscrew the base nut (3) and remove the cartridge from the hydraulic filter.
- Screw a new cartridge into place.
- Put the machine back into the operational configuration.

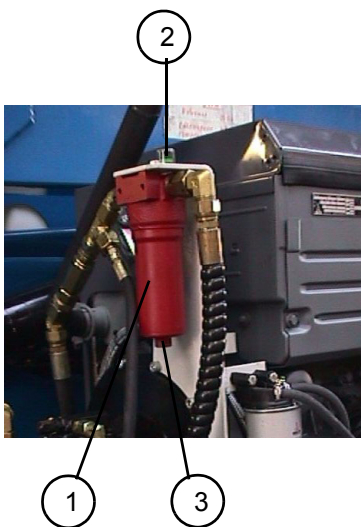

HA16/18 PX  
 HA46/51JRT  
 HA20/26 PX  
 HA61/80JRT

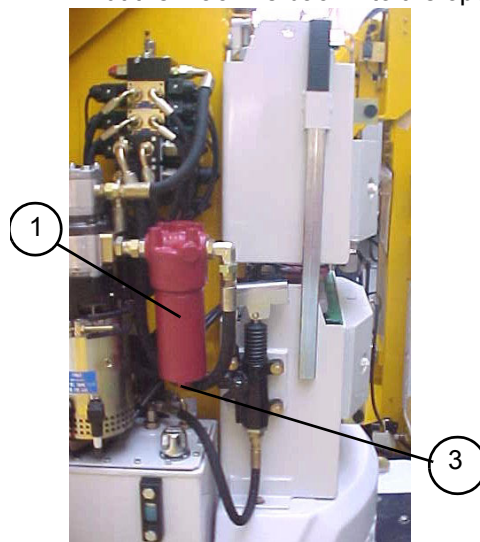

STAR 22 J / Star 8

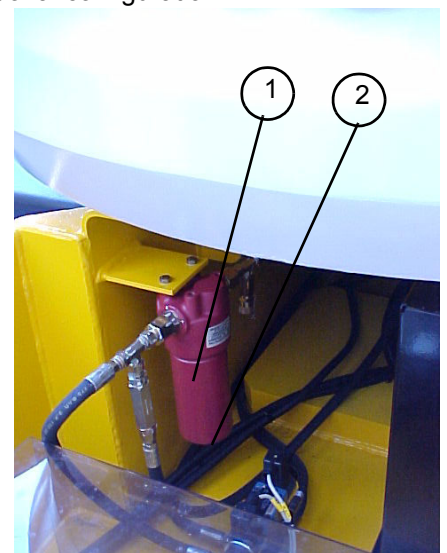

HA12IP - HA33JE

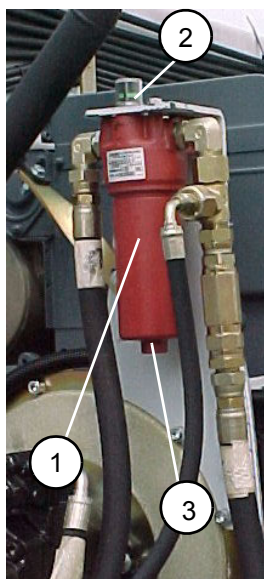

H14P / H16TP  
 HB40/44J

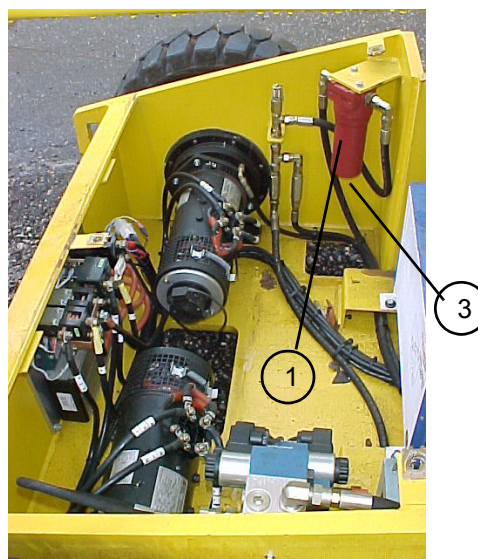

HA15I - HA43E

|  |                              |  |
|--|------------------------------|--|
|  | PREVENTIVE MAINTENANCE SHEET |  |
|  |                              |  |

|            |  |           |
|------------|--|-----------|
| Sheet P007 | PREVENTIVE MAINTENANCE SHEET                         | Folio 1/1 |
|            | CHECKING - CHANGING THE OIL OF A WHEEL REDUCING GEAR |           |

 **Caution!**

*Use a container to collect oil to prevent pollution of the environment.*

 **Caution!**

*Make sure that the machine is properly stabilised, and that the lifting means are in good condition and of sufficient capacity.*

**2 - Preliminary operations**

- Put the machine in the maintenance configuration (see corresponding paragraph).
- Switch off electric power (see corresponding paragraph).

**2 - Checking the level**

- Turn the wheel so that one cap (1) is on a horizontal line and the other (2) is on a vertical line.
- Unscrew the cap (1) and check the level that should be up to the hole. Top up if necessary.
- Screw the cap back into place.

**NB:** *Only use the oil recommended by the manufacturer.*

**3 - Changing the oil**

- In the same position or in (3) position, unscrew the 2 caps and let the oil flow out.
- Re-fill as described above.
- Screw the caps back into place.

**NB:** *Collect old oil to prevent pollution of the environment.*

**4 - Additional operations**

- Put the machine back into the operational configuration.



HA16/18PX - HA46/51JRT  
HA20/26 PX - HA61/80JRT

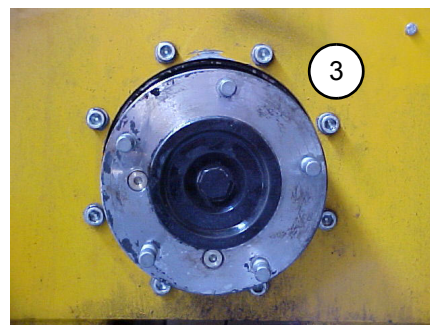
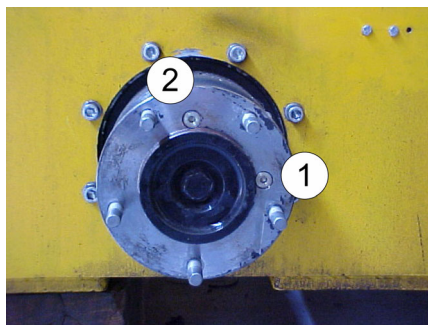

HA15I - HA43E



H14T(X) - H16TP(X)  
HB40/44J

|  |                              |  |
|--|------------------------------|--|
|  | PREVENTIVE MAINTENANCE SHEET |  |
|  |                              |  |

|            |   |           |
|------------|---|-----------|
| Sheet P010 | PREVENTIVE MAINTENANCE SHEET                | Folio 1/2 |
|            | CHECKING / SERVICING THE TRACTION BATTERIES |           |



**Caution!**

These operations require safety precautions (wear gloves and protective goggles).



**Caution!**

Do not electric arc weld on the machine without first disconnecting the batteries.



**Caution!**

Do not use the batteries to jump start another vehicle.

**1 - Preliminary operations**

- Put the machine into the maintenance configuration (see relevant section).

**2 - Battery servicing**

- Check the electrolyte levels before charging once a week in normal use.
- If necessary, top up:
  - with distilled or de-mineralised water,
  - after charging.
- No not add acid (in the event of spillage, contact our After-sales department).
- Do not leave discharged batteries idle.
- Avoid overflow.
- Clean the batteries to avoid salt formation and current deviation.
- Wash the top without removing the caps.
- Dry with compressed air or clean cloths.
- Grease the lugs.

NB:

To enable rapid diagnosis of the state of your batteries, note the density of each element once a month, using a battery hydrometer, as a function of temperature, using the graph below (do not measure directly after filling).

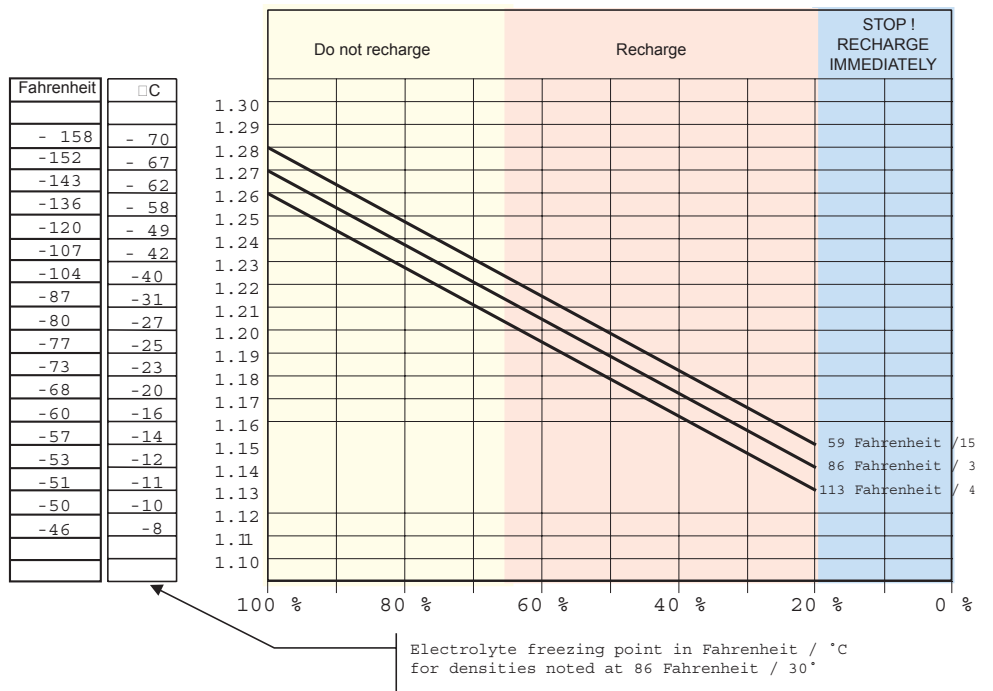

State of charge of a battery as a function of density and temperature

|            |   |           |
|------------|---|-----------|
| Sheet P010 | PREVENTIVE MAINTENANCE SHEET                | Folio 2/2 |
|            | CHECKING / SERVICING THE TRACTION BATTERIES |           |

---

## 8 - OPERATING INCIDENTS

---

REMINDER: If the instructions for using and servicing the machine are followed, most incidents will be avoided.

However, some incidents may arise and before any intervention, it is essential to check this section to see if the incident is mentioned, in which case, just follow the instructions.

Otherwise, contact your HAULOTTE agent or the plant's After-sales service.

Before searching for a breakdown, first check the following:

- battery break closed
- emergency stop "palm buttons" on the platform and turntable unlocked
- turntable panel circuit breakers pushed in
- relays (platform control panel - turntable box) correctly inserted in their base.

The chopper has a built-in failure indication system with a flashing green led. Count the number of times the led flashes in a series to identify the failure. Each series is separated by a period of led extinction. A series may include between 2 and 11 flashes. However, the led may stay on all the time, which means that chopper operation is OK. If the led remains off, check that platform power is on and call HAULOTTE after-sales (boom photo 14).

*NB: The protective cover must be removed for this check.*

**8.1 - CHOPPER DISPLAY**

| GREEN LED         | PROBABLE CAUSES   | SOLUTIONS   |
|-------------------|---|---|
| Off               | <ul style="list-style-type: none"> <li>No power</li> <li>Defective LED</li> <li>Defective chopper</li> </ul>  | <ul style="list-style-type: none"> <li>Check:                             <ul style="list-style-type: none"> <li>battery connection</li> <li>battery breaker</li> <li>emergency stops</li> <li>circuit breakers</li> <li>chopper fuses</li> </ul> </li> <li>Check that all are working properly</li> <li>Replace the chopper</li> </ul> |
| 2 flashes         | <ul style="list-style-type: none"> <li>Startup procedure fault: no pedal control</li> </ul>                   | <ul style="list-style-type: none"> <li>Press the emergency stop then reset and start again, pressing the pedal first, then activating the manipulator.</li> </ul>   |
| 3 flashes         | <ul style="list-style-type: none"> <li>Short-circuited chopper</li> </ul>                                     | <ul style="list-style-type: none"> <li>Check the power cables</li> <li>Find the short-circuit</li> </ul>  |
| 4 flashes         | <ul style="list-style-type: none"> <li>Pump contacts KM2 - KM3 stuck or in short-circuit</li> </ul>           | <ul style="list-style-type: none"> <li>Check the power cables</li> <li>Find the short-circuit on the contacts and pump motor</li> <li>Check contacts KM2 and KM3</li> </ul>   |
| 5 flashes         | <ul style="list-style-type: none"> <li>Pump contacts KM2 - KM3 or line contact KM1 are not closing</li> </ul> | <ul style="list-style-type: none"> <li>Check the contactor contacts</li> <li>Check the power cables</li> <li>Check connection of the control circuit cables (thin wires)</li> </ul>   |
| 6 flashes         | <ul style="list-style-type: none"> <li>Accelerator fault, defective manipulator</li> </ul>                    | <ul style="list-style-type: none"> <li>Check manipulator connection</li> <li>Check connection of the wiring harness at chopper input</li> </ul>   |
| 7 flashes         | <ul style="list-style-type: none"> <li>Battery discharged less than 13 volts</li> </ul>                       | <ul style="list-style-type: none"> <li>Check battery charge</li> <li>Check battery terminals</li> <li>Check power cables</li> <li>Check the battery breaker</li> </ul>  |
| 8 flashes         | <ul style="list-style-type: none"> <li>80 ° C temperature safety system</li> </ul>                            | <ul style="list-style-type: none"> <li>Check if the chopper is hot, and leave to cool</li> <li>If the situation persists, stop the machine</li> </ul>   |
| 10 and 11 flashes | <ul style="list-style-type: none"> <li>Tachometer fault</li> </ul>  | <ul style="list-style-type: none"> <li>Check connection of the generator (2 - ph.11)</li> <li>Check connections on the chopper's electronic card (2 - ph.15).</li> <li>State of fuse</li> </ul>   |

After each check, push the emergency stop, then reset and check the led on the chopper.

In general:

After reading the chopper's diagnosis and performing the checks described above, if the problem persists, contact HAULOTTE's after-sales service.

**8.2 - TROUBLESHOOTING**

| INCIDENT  | PROBABLE CAUSE   | SOLUTION       |
|---|--|----------------|
| <p>No travel movement in either direction FOR / REV</p> | <ul style="list-style-type: none"> <li>• Damaged or defective travel manipulator</li> <li>• Damaged or defective chopper</li> <li>• Damaged or defective movement selector SA7</li> <li>• Damaged or defective electric cable</li> <li>• Damaged or defective connector</li> <li>• Damaged or defective platform palm button SB2</li> <li>• Damaged or defective control panel selection key switch</li> <li>• Damaged or defective push button SB1</li> <li>• Damaged or defective connections &amp; screws</li> <li>• Damaged or defective fuse FU2</li> <li>• Discharged or defective batteries</li> </ul>  | <p>• DP136</p> |
| <p>No high speed available</p>                          | <ul style="list-style-type: none"> <li>• Damaged or defective chopper</li> <li>• Damaged or defective converter</li> <li>• Damaged or defective pump</li> <li>• Damaged or defective tilt detector</li> <li>• Damaged or defective key selector</li> <li>• Damaged or defective electric wiring or connector</li> <li>• Damaged or defective fuses FU1, FU2, FU3</li> <li>• Damaged or defective relay KA5</li> <li>• Damaged or defective contacts KM1, KM3</li> <li>• Damaged or defective circuit breaker QF2</li> <li>• Damaged or defective battery breaker QS1</li> <li>• Damaged or defective switch SA2</li> <li>• Damaged or defective selector SB1, SB2</li> <li>• Damaged or defective position switch SQ1, SQ2, SQ5</li> <li>• Damaged or defective diode V5</li> <li>• Discharged or defective batteries</li> </ul> | <p>• DP137</p> |
| <p>The charger does not charge</p>                      | <ul style="list-style-type: none"> <li>• Discharged or defective batteries</li> <li>• Damaged or defective wiring</li> <li>• Damaged or defective battery terminals</li> </ul>   | <p>• DP138</p> |
| <p>No compensation movement from the platform</p>       | <ul style="list-style-type: none"> <li>• Damaged or defective converter</li> <li>• Damaged or defective manipulator</li> <li>• Damaged or defective movement selector</li> <li>• Damaged or defective relay</li> <li>• Damaged or defective electric wiring or connector</li> <li>• Damaged or defective hydraulic hoses and connections</li> <li>• Damaged or defective converter fuse</li> <li>• Damaged or defective coils</li> <li>• Damaged or defective circuit breaker QF1</li> <li>• Damaged or defective battery breaker QS1</li> <li>• Damaged or defective switches SA1, SA7</li> <li>• Damaged or defective selector SB1, SB2</li> <li>• Distributor pressure limiter defective or needing recalibration</li> <li>• Discharged or defective batteries</li> </ul>   | <p>• DP139</p> |

| INCIDENT  | PROBABLE CAUSE  | SOLUTION  |
|---|---|---|
| <p>No slewing movement from the platform</p>      | <ul style="list-style-type: none"> <li>• Damaged or defective manipulator</li> <li>• Damaged or defective movement selector</li> <li>• Damaged or defective relay</li> <li>• Damaged or defective electric wiring or connector</li> <li>• Damaged or defective hydraulic hoses and connections</li> <li>• Damaged or defective circuit breaker QF1</li> <li>• Damaged or defective battery breaker QS1</li> <li>• Damaged or defective switches SA1, SA7</li> <li>• Damaged or defective selector SB1</li> <li>• Damaged or defective palm button SB2°</li> <li>• Damaged or defective coil YV4</li> <li>• Blocked or defective hydraulic slide valve</li> <li>• Damaged or defective valve</li> <li>• Damaged or defective converter fuse</li> <li>• Damaged or defective converter</li> <li>• Discharged or defective batteries</li> </ul>                              | <ul style="list-style-type: none"> <li>• DP140</li> </ul> |
| <p>No arm lifting movement from the platform</p>  | <ul style="list-style-type: none"> <li>• Damaged or defective manipulator</li> <li>• Damaged or defective movement selector</li> <li>• Damaged or defective relay</li> <li>• Damaged or defective electric wiring or connector</li> <li>• Damaged or defective circuit breaker QF1</li> <li>• Damaged or defective battery breaker QS1</li> <li>• Damaged or defective switches SA1, SA7</li> <li>• Damaged or defective selector SB1</li> <li>• Damaged or defective palm button SB2°</li> <li>• Damaged or defective coils YV5,...</li> <li>• Damaged or defective balancing valve</li> <li>• Damaged or defective controlled flap on the arm lifting cylinder</li> <li>• Blocked or defective hydraulic slide valve</li> <li>• Damaged or defective converter fuse</li> <li>• Damaged or defective converter</li> <li>• Discharged or defective batteries</li> </ul>   | <ul style="list-style-type: none"> <li>• DP141</li> </ul> |
| <p>No boom lifting movement from the platform</p> | <ul style="list-style-type: none"> <li>• Damaged or defective manipulator</li> <li>• Damaged or defective movement selector</li> <li>• Damaged or defective relay</li> <li>• Damaged or defective electric wiring or connector</li> <li>• Damaged or defective circuit breaker QF1</li> <li>• Damaged or defective battery breaker QS1</li> <li>• Damaged or defective switches SA1, SA7</li> <li>• Damaged or defective selector SB1</li> <li>• Damaged or defective palm button SB2°</li> <li>• Damaged or defective coils YV6,...</li> <li>• Damaged or defective balancing valve</li> <li>• Damaged or defective controlled valve on the boom lifting cylinder</li> <li>• Blocked or defective hydraulic slide valve</li> <li>• Damaged or defective converter fuse</li> <li>• Damaged or defective converter</li> <li>• Discharged or defective batteries</li> </ul> | <ul style="list-style-type: none"> <li>• DP142</li> </ul> |

| INCIDENT  | PROBABLE CAUSE  | SOLUTION  |
|---|---|---|
| Notelescoping movement from the platform                      | <ul style="list-style-type: none"> <li>• Damaged or defective manipulator</li> <li>• Damaged or defective movement selector</li> <li>• Damaged or defective relay</li> <li>• Damaged or defective electric wiring or connector</li> <li>• Damaged or defective circuit breaker QF1</li> <li>• Damaged or defective battery breaker QS1</li> <li>• Damaged or defective switches SA1, SA7</li> <li>• Damaged or defective selector SB1</li> <li>• Damaged or defective palm button SB2°</li> <li>• Damaged or defective coils YV7,...</li> <li>• Damaged or defective balancing valve</li> <li>• Damaged or defective controlled flap on the telescoping cylinder</li> <li>• Blocked or defective hydraulic slide valve</li> <li>• Damaged or defective converter fuse</li> <li>• Damaged or defective converter</li> <li>• Discharged or defective batteries</li> </ul> | <ul style="list-style-type: none"> <li>• DP143</li> </ul> |
| No low speed available from the platform control panel        | <ul style="list-style-type: none"> <li>• Damaged or defective switch SA2</li> <li>• Damaged or defective chopper</li> <li>• Discharged or defective batteries</li> </ul>  | <ul style="list-style-type: none"> <li>• DP144</li> </ul> |
| No slewing movement in either direction L/R from the platform | <ul style="list-style-type: none"> <li>• Damaged or defective manipulator</li> <li>• Damaged or defective relays KA8, KA9</li> <li>• Damaged or defective circuit breakers QF1, QF2</li> <li>• Damaged or defective battery breaker QS1</li> <li>• Damaged or defective switches SA1, SA7</li> <li>• Damaged or defective selector SB1</li> <li>• Damaged or defective palm button SB2</li> <li>• Damaged or defective hydraulic hoses and connections</li> <li>• Damaged or defective balancing valve</li> <li>• Blocked or defective hydraulic slide valve</li> <li>• Damaged or defective converter fuse</li> <li>• Damaged or defective converter</li> <li>• Discharged or defective batteries</li> </ul>   | <ul style="list-style-type: none"> <li>• DP145</li> </ul> |
| The electro-pump does not work from the platform              | <ul style="list-style-type: none"> <li>• Damaged or defective manipulator</li> <li>• Damaged or defective relay KA14</li> <li>• Damaged or defective electric wiring or connector</li> <li>• Damaged or defective contact KM1, KM3</li> <li>• Damaged or defective fuses FU1, FU2, FU3</li> <li>• Damaged or defective chopper</li> <li>• Damaged or defective pump</li> <li>• Damaged or defective key selector SB1</li> <li>• Discharged or defective batteries</li> </ul>  | <ul style="list-style-type: none"> <li>• DP146</li> </ul> |
| Notelescoping movement from the turntable control panel       | <ul style="list-style-type: none"> <li>• Damaged or defective pump</li> <li>• Damaged or defective circuit breaker QF1</li> <li>• Damaged or defective battery breaker QS1</li> <li>• Damaged or defective switches SA1, SA6</li> <li>• Damaged or defective selector SB1</li> <li>• Damaged or defective coil YV7</li> <li>• Damaged or defective balancing valve</li> <li>• Damaged or defective controlled flap on the telescoping cylinder</li> <li>• Blocked or defective hydraulic slide valve</li> <li>• Damaged or defective converter fuse</li> <li>• Damaged or defective converter</li> <li>• Discharged or defective batteries</li> </ul>   | <ul style="list-style-type: none"> <li>• DP147</li> </ul> |

| INCIDENT   | PROBABLE CAUSE   | SOLUTION  |
|--|--|---|
| <p>No boom lifting movement from the turntable control panel</p>       | <ul style="list-style-type: none"> <li>• Damaged or defective pump</li> <li>• Damaged or defective circuit breaker QF1</li> <li>• Damaged or defective battery breaker QS1</li> <li>• Damaged or defective switches SA1, SA5</li> <li>• Damaged or defective selector SB1</li> <li>• Damaged or defective coil YV6</li> <li>• Damaged or defective balancing valve</li> <li>• Damaged or defective controlled flap on the boom lifting cylinder</li> <li>• Blocked or defective hydraulic slide valve</li> <li>• Damaged or defective converter fuse</li> <li>• Damaged or defective converter</li> <li>• Discharged or defective batteries</li> </ul> | <ul style="list-style-type: none"> <li>• DP148</li> </ul> |
| <p>No arm lifting movement from the turntable control panel</p>        | <ul style="list-style-type: none"> <li>• Damaged or defective pump</li> <li>• Damaged or defective circuit breaker QF1</li> <li>• Damaged or defective battery breaker QS1</li> <li>• Damaged or defective switches SA1, SA4</li> <li>• Damaged or defective selector SB1</li> <li>• Damaged or defective coil YV5</li> <li>• Damaged or defective balancing valve</li> <li>• Damaged or defective controlled flap on the arm lifting cylinder</li> <li>• Blocked or defective hydraulic slide valve</li> <li>• Damaged or defective converter fuse</li> <li>• Damaged or defective converter</li> <li>• Discharged or defective batteries</li> </ul>  | <ul style="list-style-type: none"> <li>• DP149</li> </ul> |
| <p>No slewing movement L/R from the turntable control panel</p>        | <ul style="list-style-type: none"> <li>• Damaged or defective pump</li> <li>• Damaged or defective circuit breaker QF1</li> <li>• Damaged or defective battery breaker QS1</li> <li>• Damaged or defective switches SA1, SA3</li> <li>• Damaged or defective selector SB1</li> <li>• Damaged or defective coil YV4</li> <li>• Damaged or defective balancing valve</li> <li>• Damaged or defective hydraulic hoses and connections</li> <li>• Blocked or defective hydraulic slide valve</li> <li>• Damaged or defective converter fuse</li> <li>• Damaged or defective converter</li> <li>• Discharged or defective batteries</li> </ul>              | <ul style="list-style-type: none"> <li>• DP150</li> </ul> |
| <p>The electro-pump does not work from the turntable control panel</p> | <ul style="list-style-type: none"> <li>• Damaged or defective pump</li> <li>• Damaged or defective chopper</li> <li>• Damaged or defective selectors SB1, SB4</li> <li>• Damaged or defective turntable/platform panel key selector</li> <li>• Damaged or defective fuse FU2 on the chopper</li> <li>• Damaged or defective electric wiring or connector</li> <li>• Discharged or defective batteries</li> </ul>   | <ul style="list-style-type: none"> <li>• DP151</li> </ul> |

|             |   |           |
|-------------|---|-----------|
| Sheet DP136 | BREAKDOWN DETECTION FLOW CHART                      | Folio 1/4 |
|             | NO TRAVEL MOVEMENT<br>IN EITHER DIRECTION FOR / REV |           |

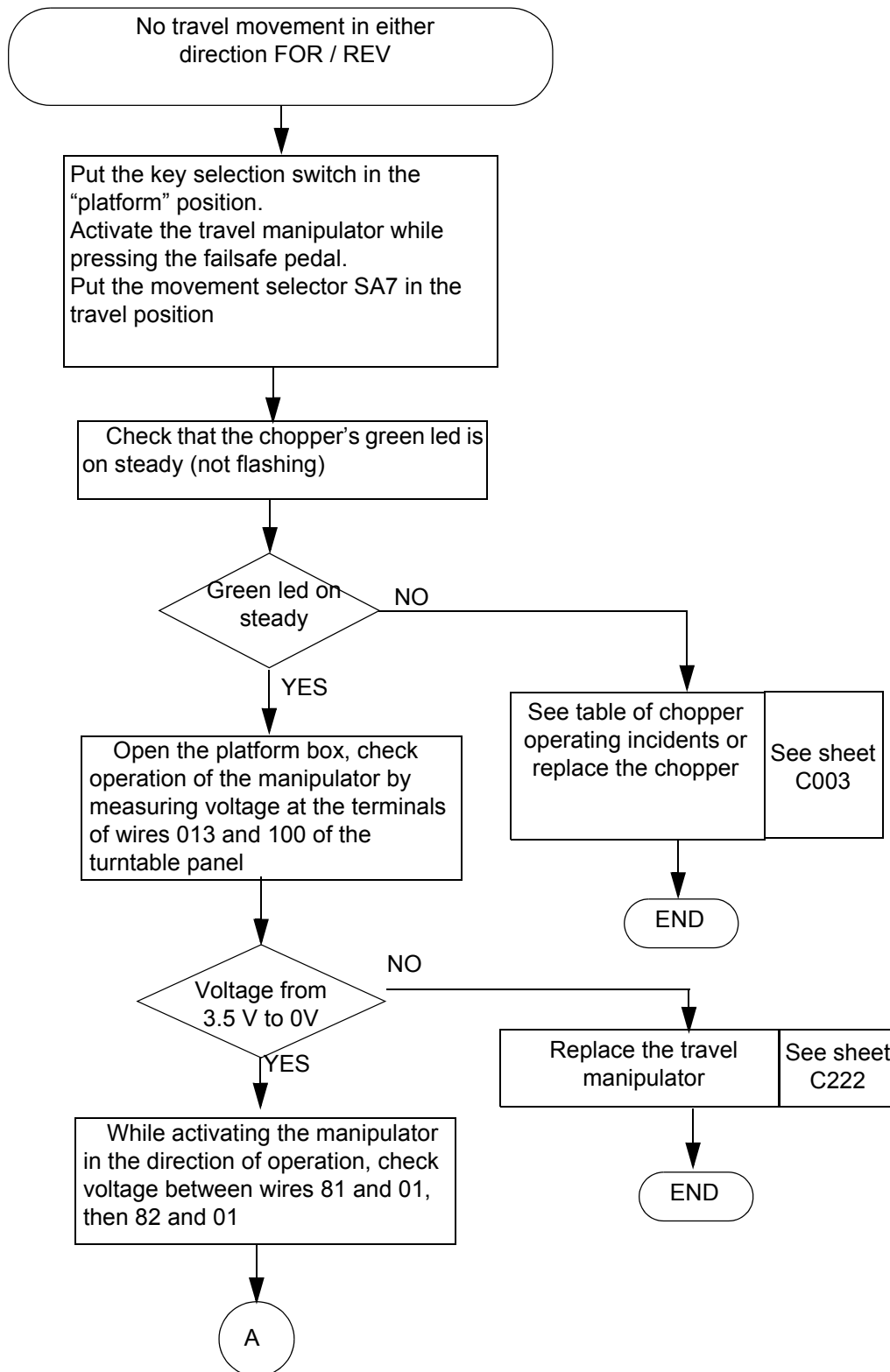

|             |   |           |
|-------------|---|-----------|
| Sheet DP136 | BREAKDOWN DETECTION FLOW CHART                      | Folio 2/4 |
|             | NO TRAVEL MOVEMENT<br>IN EITHER DIRECTION FOR / REV |           |

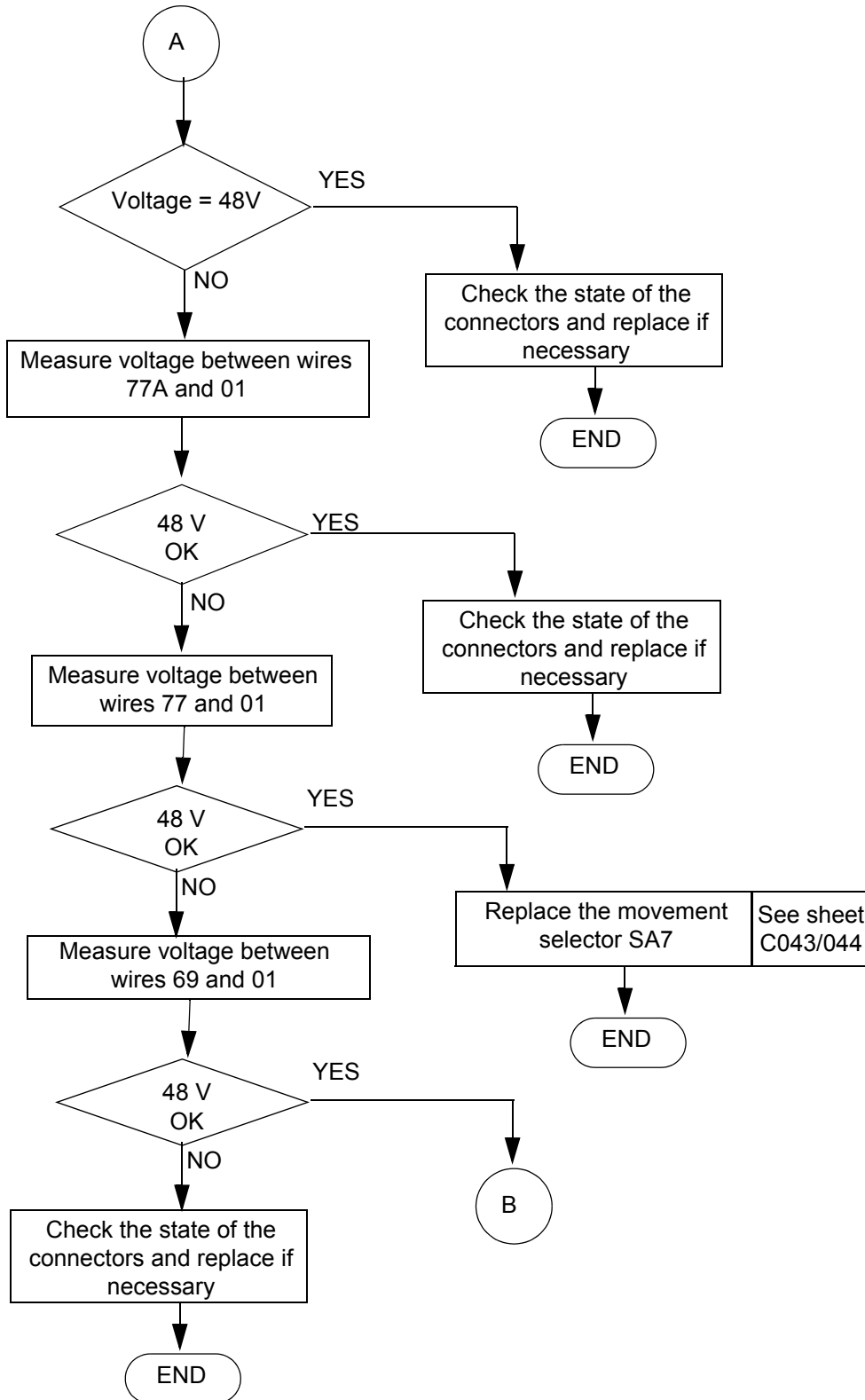

|             |   |           |
|-------------|---|-----------|
| Sheet DP136 | BREAKDOWN DETECTION FLOW CHART                      | Folio 3/4 |
|             | NO TRAVEL MOVEMENT<br>IN EITHER DIRECTION FOR / REV |           |

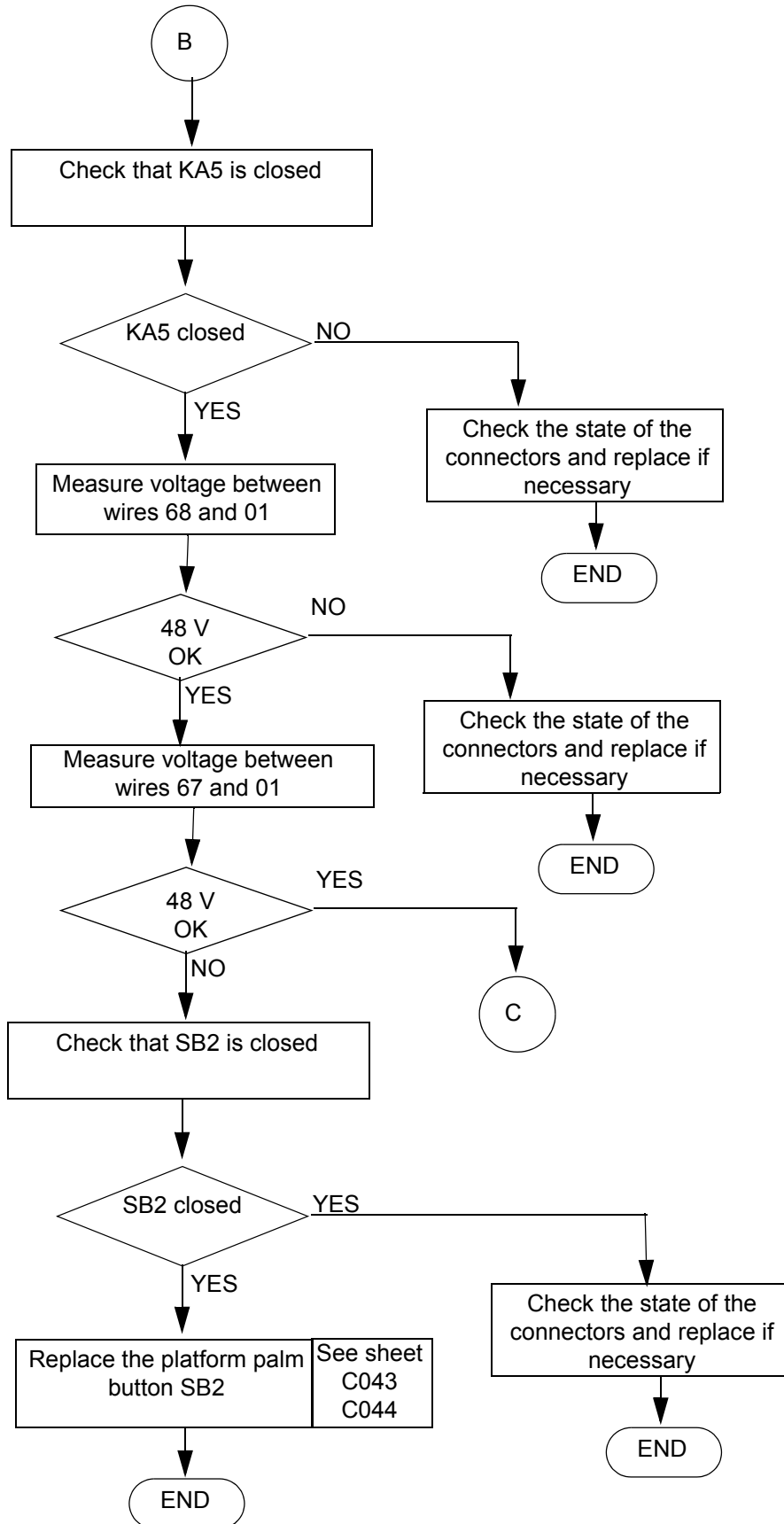

|             |   |           |
|-------------|---|-----------|
| Sheet DP136 | BREAKDOWN DETECTION FLOW CHART                      | Folio 4/4 |
|             | NO TRAVEL MOVEMENT<br>IN EITHER DIRECTION FOR / REV |           |

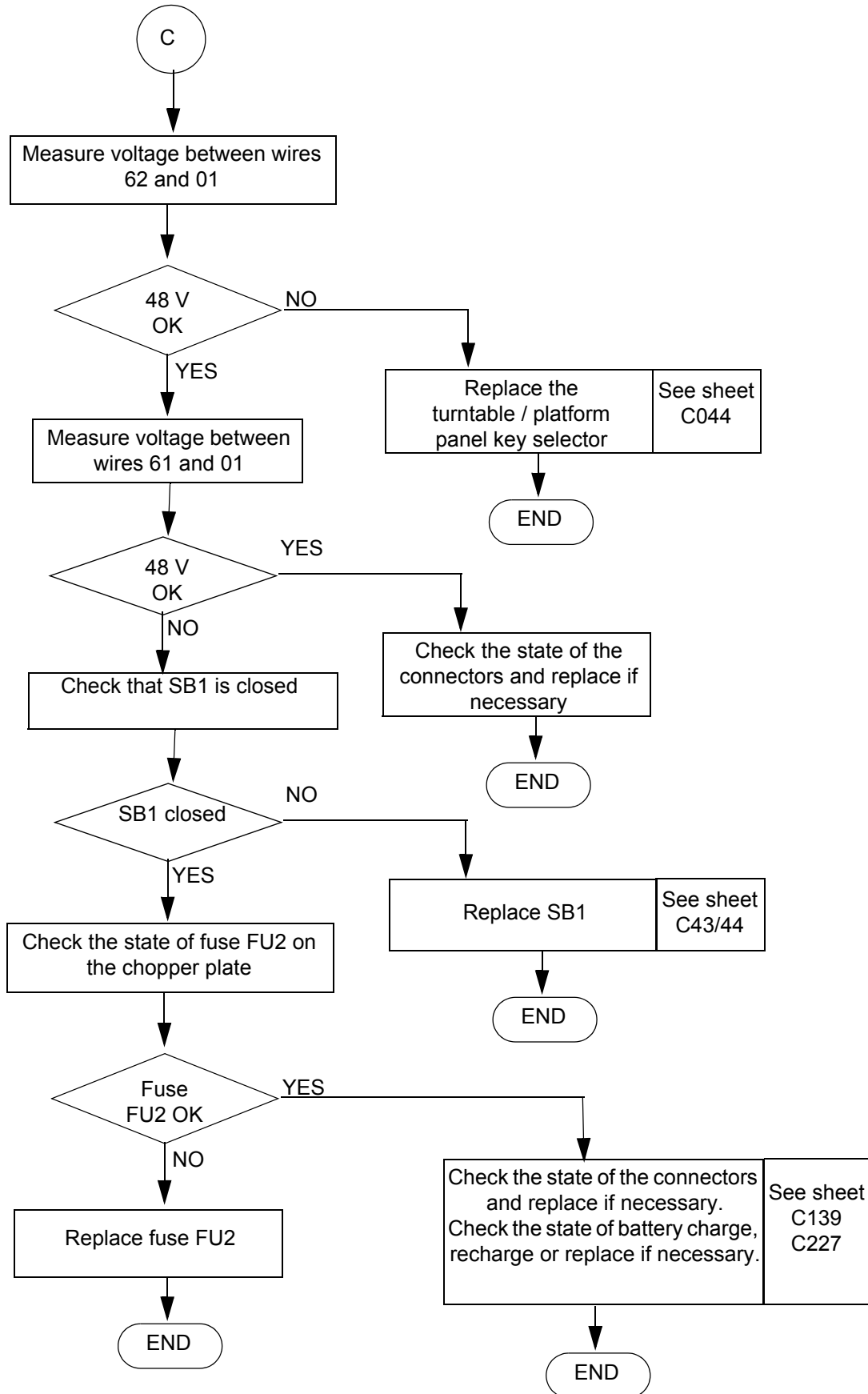

|             |                                |            |
|-------------|--------------------------------|------------|
| Sheet DP137 | BREAKDOWN DETECTION FLOW CHART | Folio 1/14 |
|             | NO HIGH SPEED                  |            |

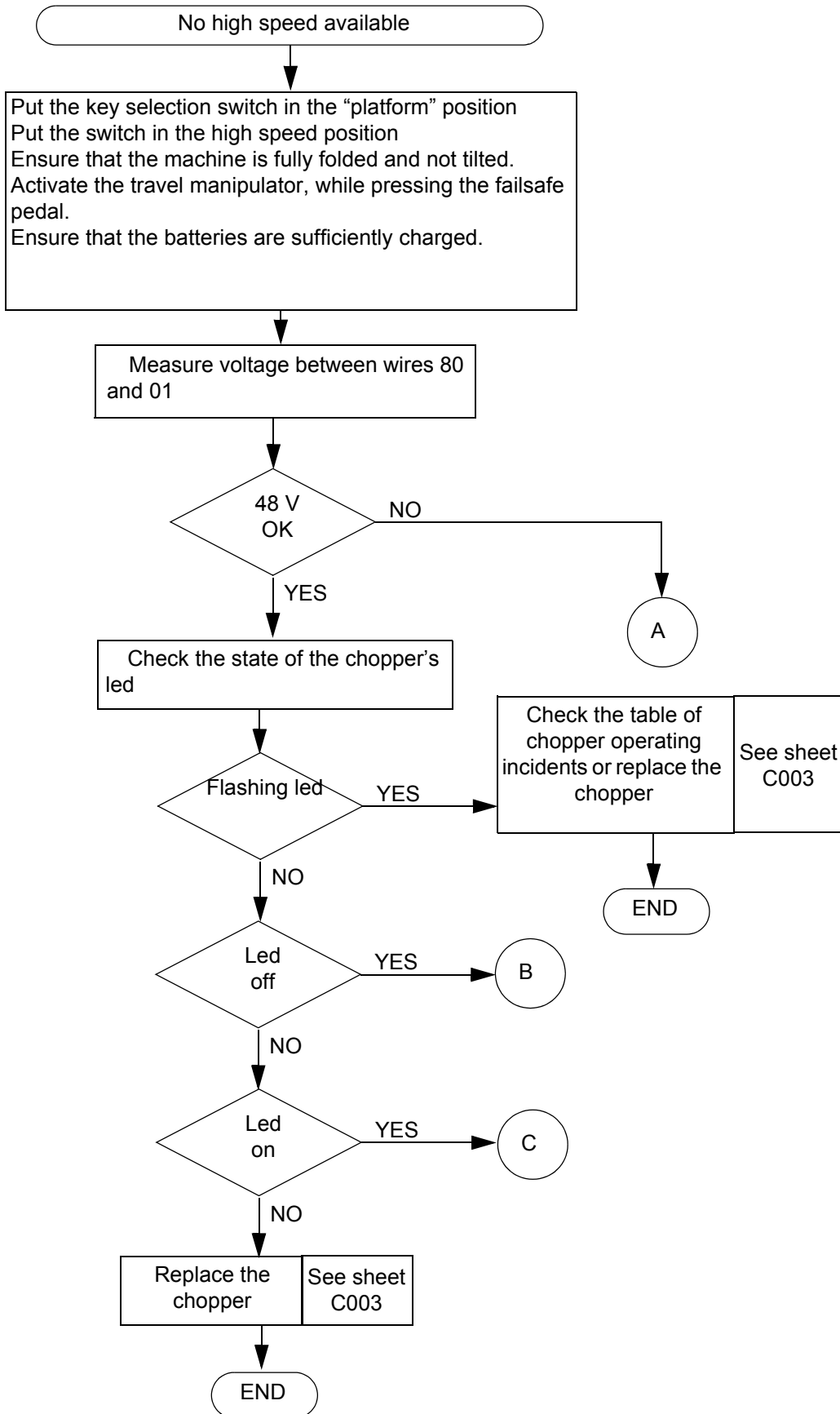

|             |                                |            |
|-------------|--------------------------------|------------|
| Sheet DP137 | BREAKDOWN DETECTION FLOW CHART | Folio 2/14 |
|             | NO HIGH SPEED                  |            |

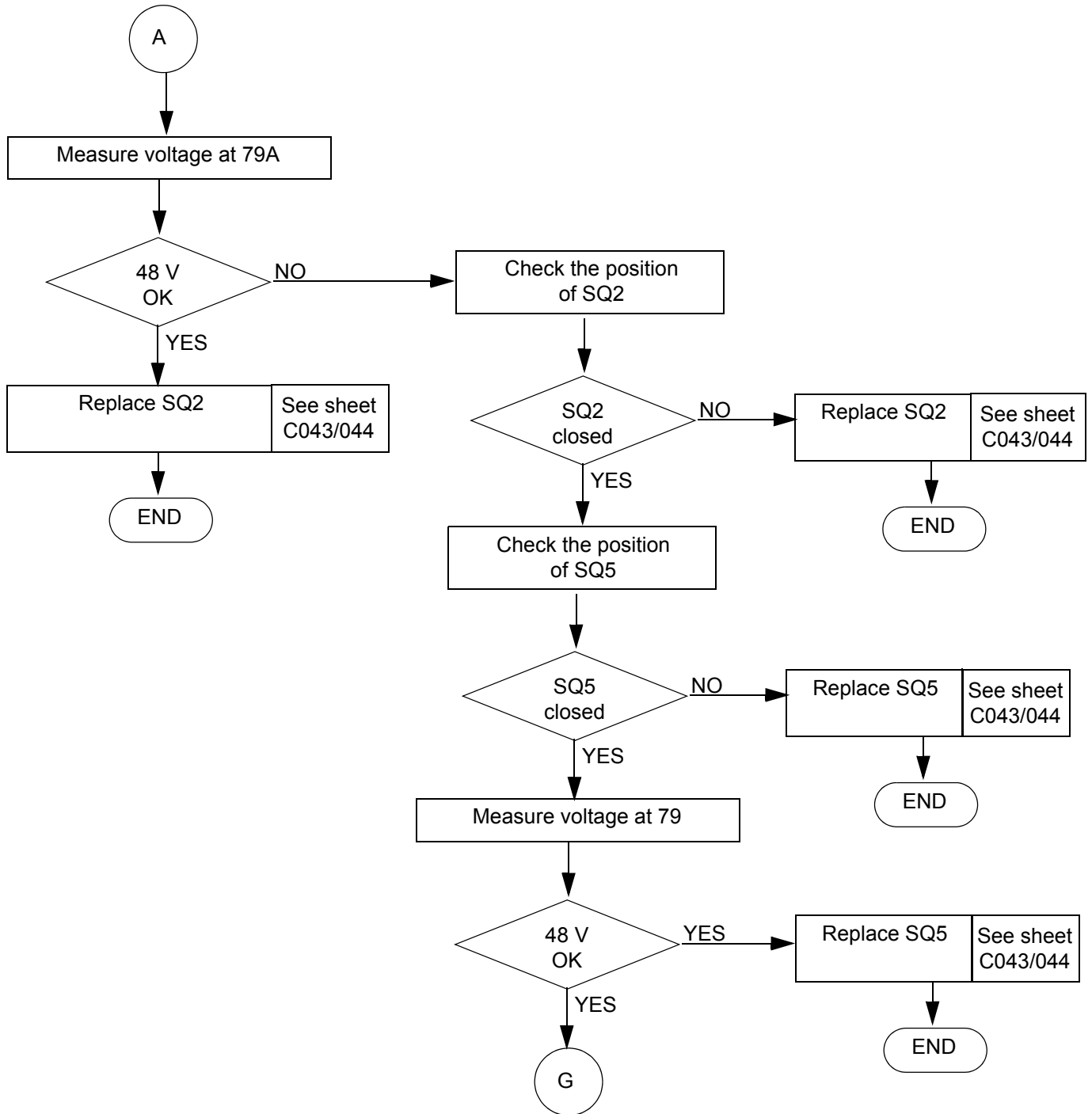

|             |                                |            |
|-------------|--------------------------------|------------|
| Sheet DP137 | BREAKDOWN DETECTION FLOW CHART | Folio 3/14 |
|             | NO HIGH SPEED                  |            |

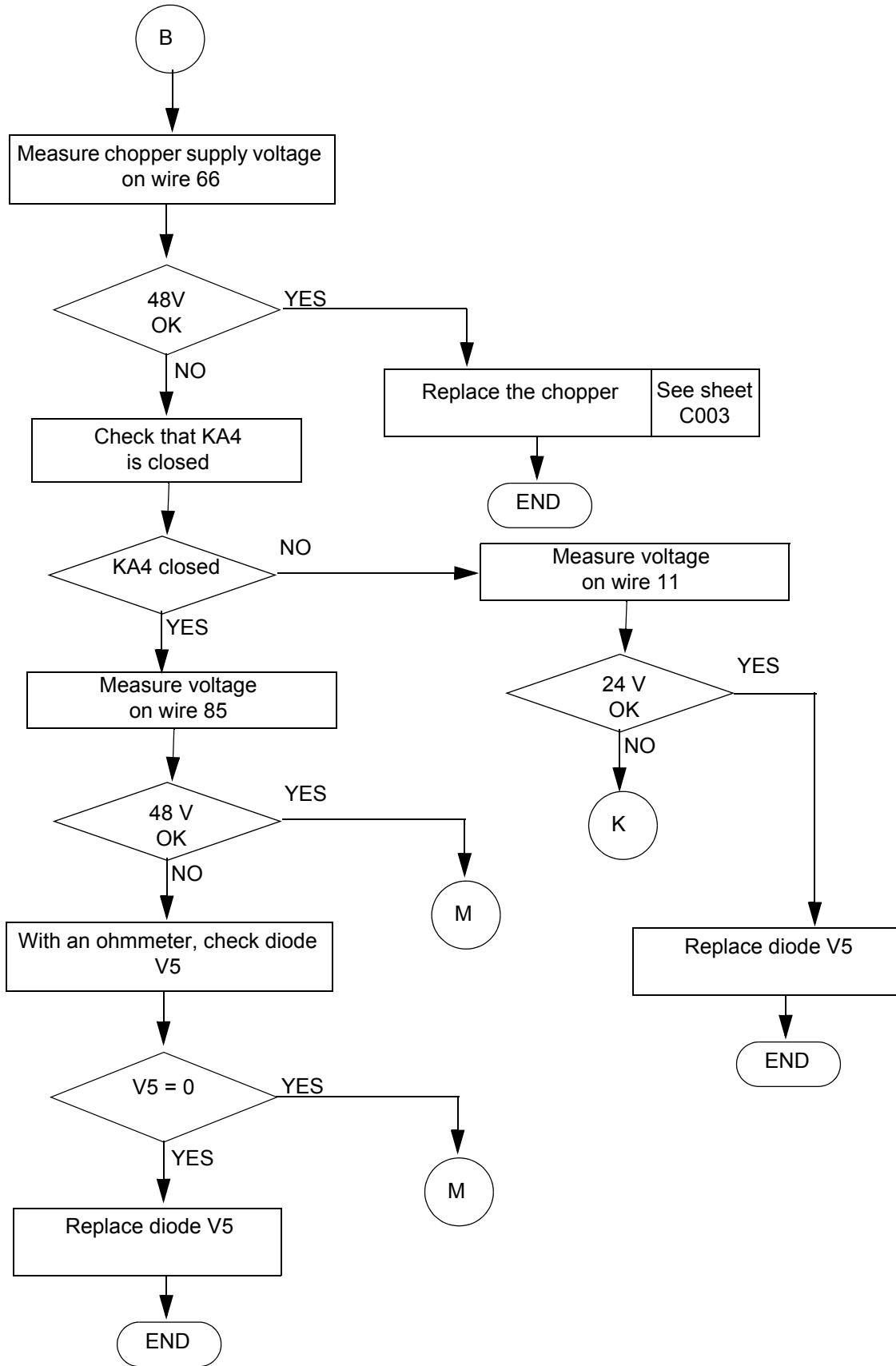

|             |                                |            |
|-------------|--------------------------------|------------|
| Sheet DP137 | BREAKDOWN DETECTION FLOW CHART | Folio 4/14 |
|             | NO HIGH SPEED                  |            |

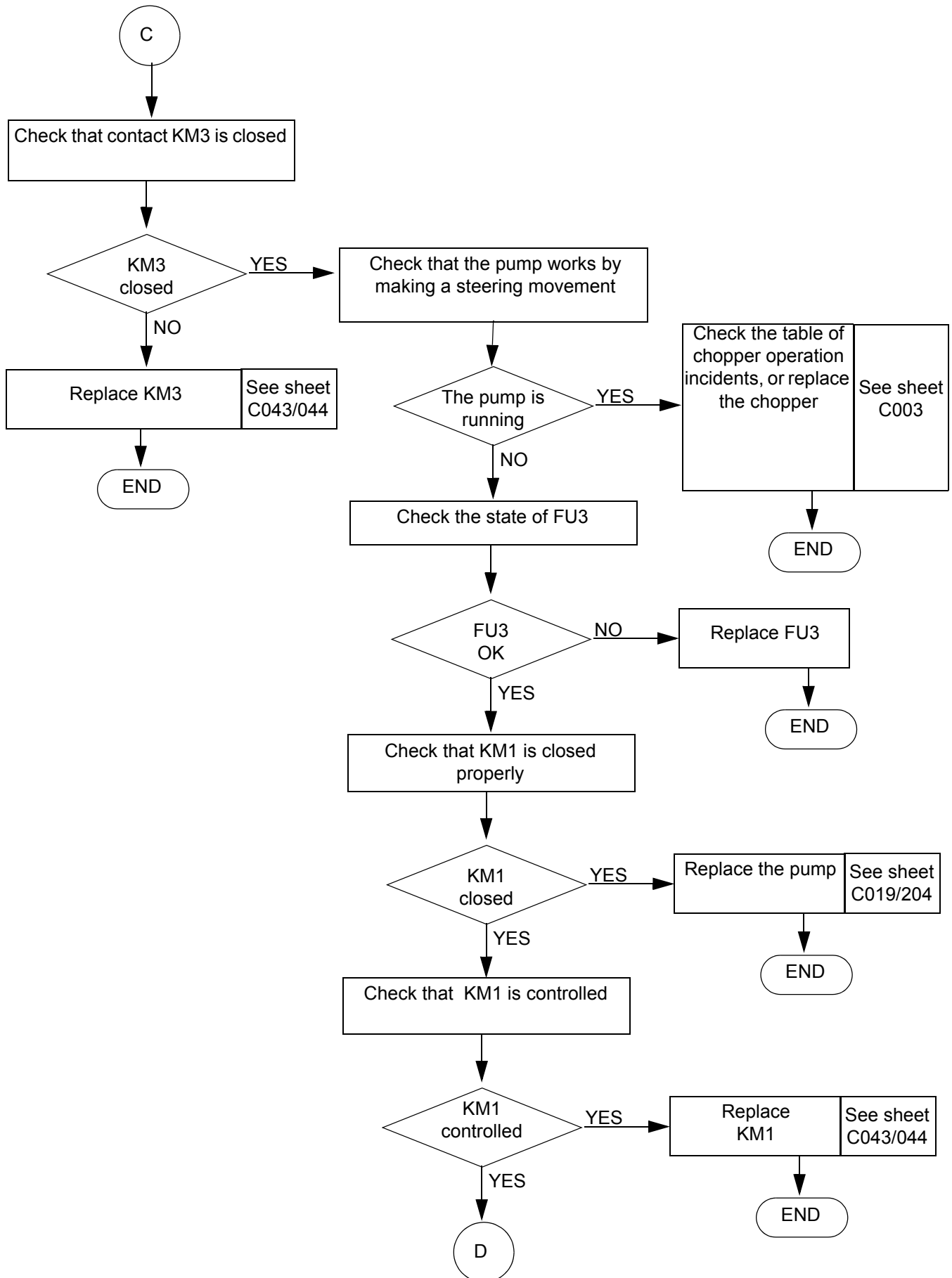

|             |                                |            |
|-------------|--------------------------------|------------|
| Sheet DP137 | BREAKDOWN DETECTION FLOW CHART | Folio 5/14 |
|             | NO HIGH SPEED                  |            |

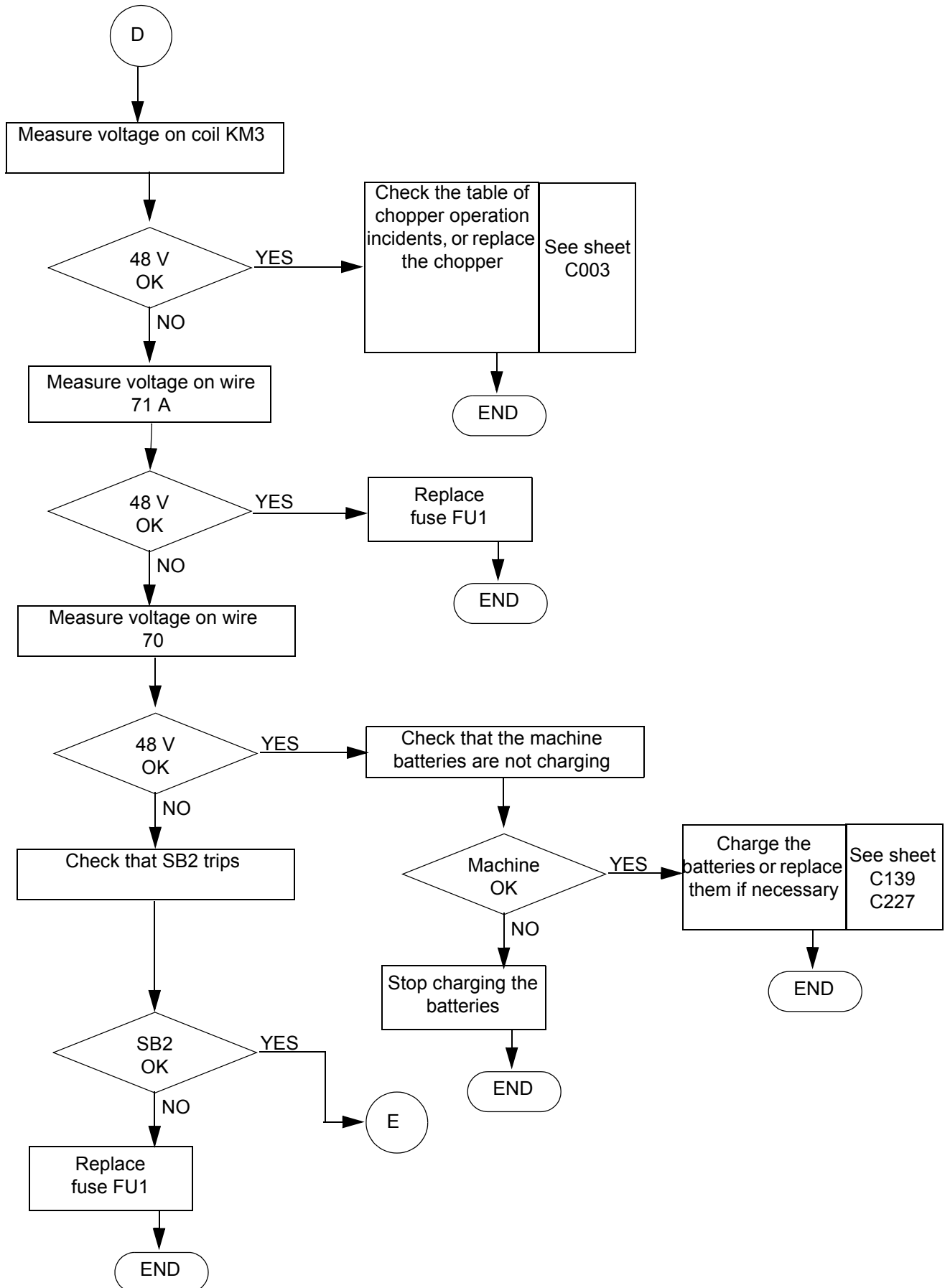

|             |                                |            |
|-------------|--------------------------------|------------|
| Sheet DP137 | BREAKDOWN DETECTION FLOW CHART | Folio 6/14 |
|             | NO HIGH SPEED                  |            |

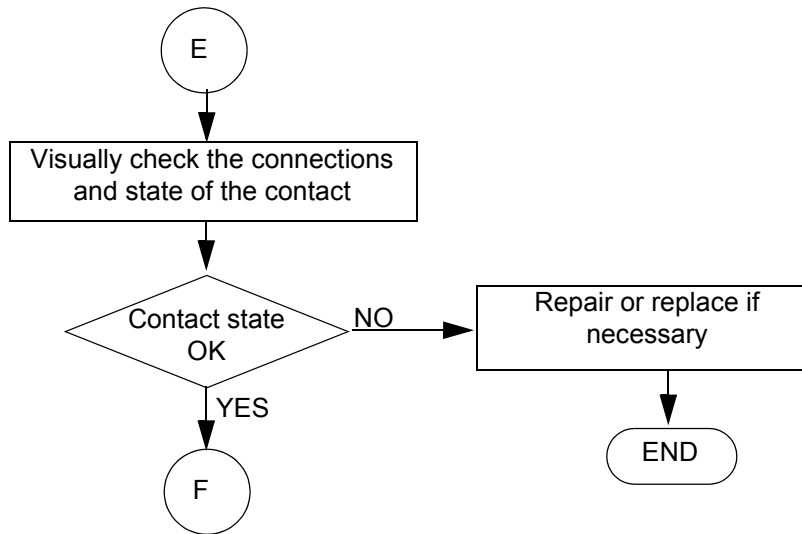

|             |                                |            |
|-------------|--------------------------------|------------|
| Sheet DP137 | BREAKDOWN DETECTION FLOW CHART | Folio 7/14 |
|             | NO HIGH SPEED                  |            |

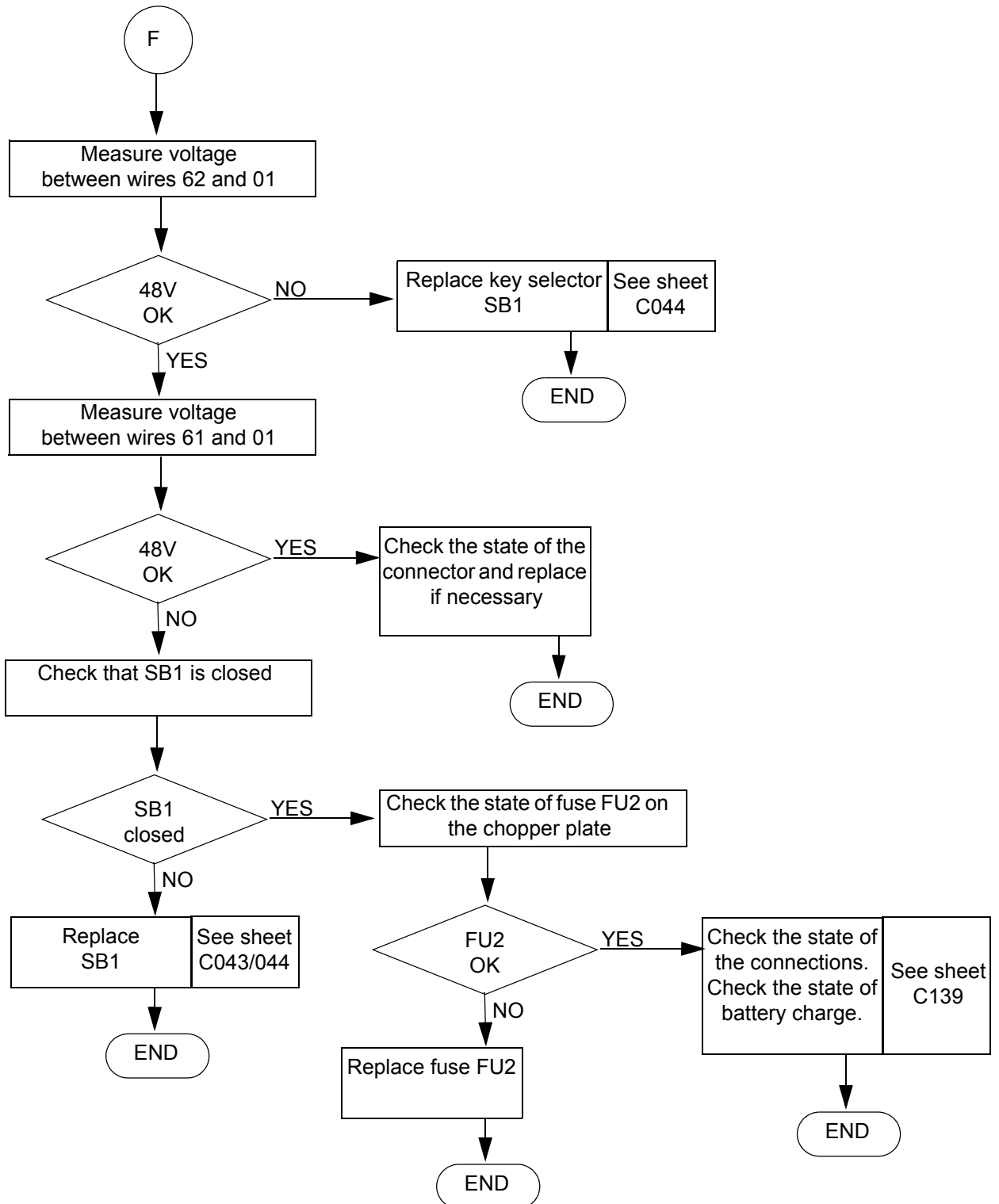

|             |                                |            |
|-------------|--------------------------------|------------|
| Sheet DP137 | BREAKDOWN DETECTION FLOW CHART | Folio 8/14 |
|             | NO HIGH SPEED                  |            |

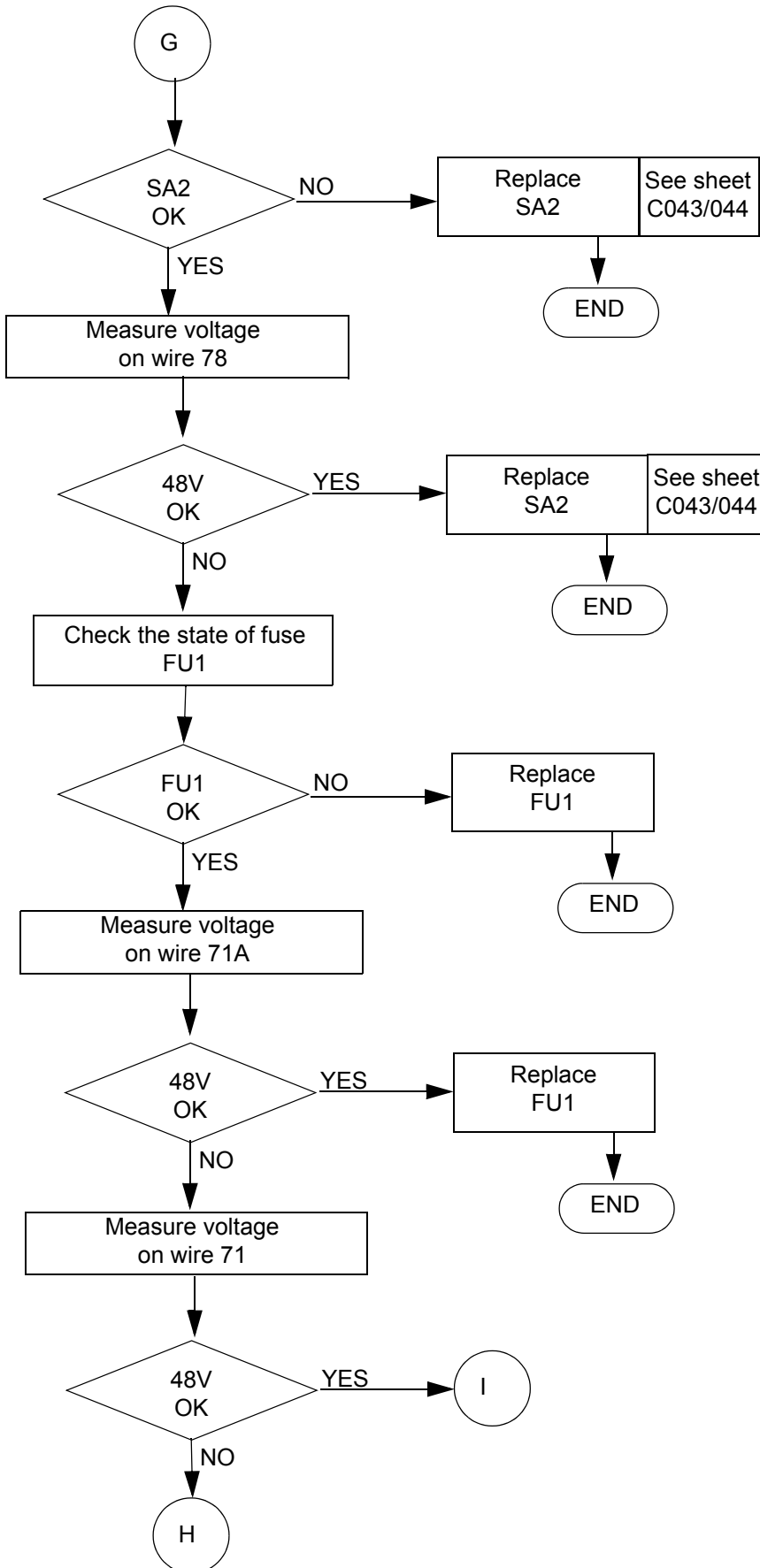

|             |                                |            |
|-------------|--------------------------------|------------|
| Sheet DP137 | BREAKDOWN DETECTION FLOW CHART | Folio 9/14 |
|             | NO HIGH SPEED                  |            |

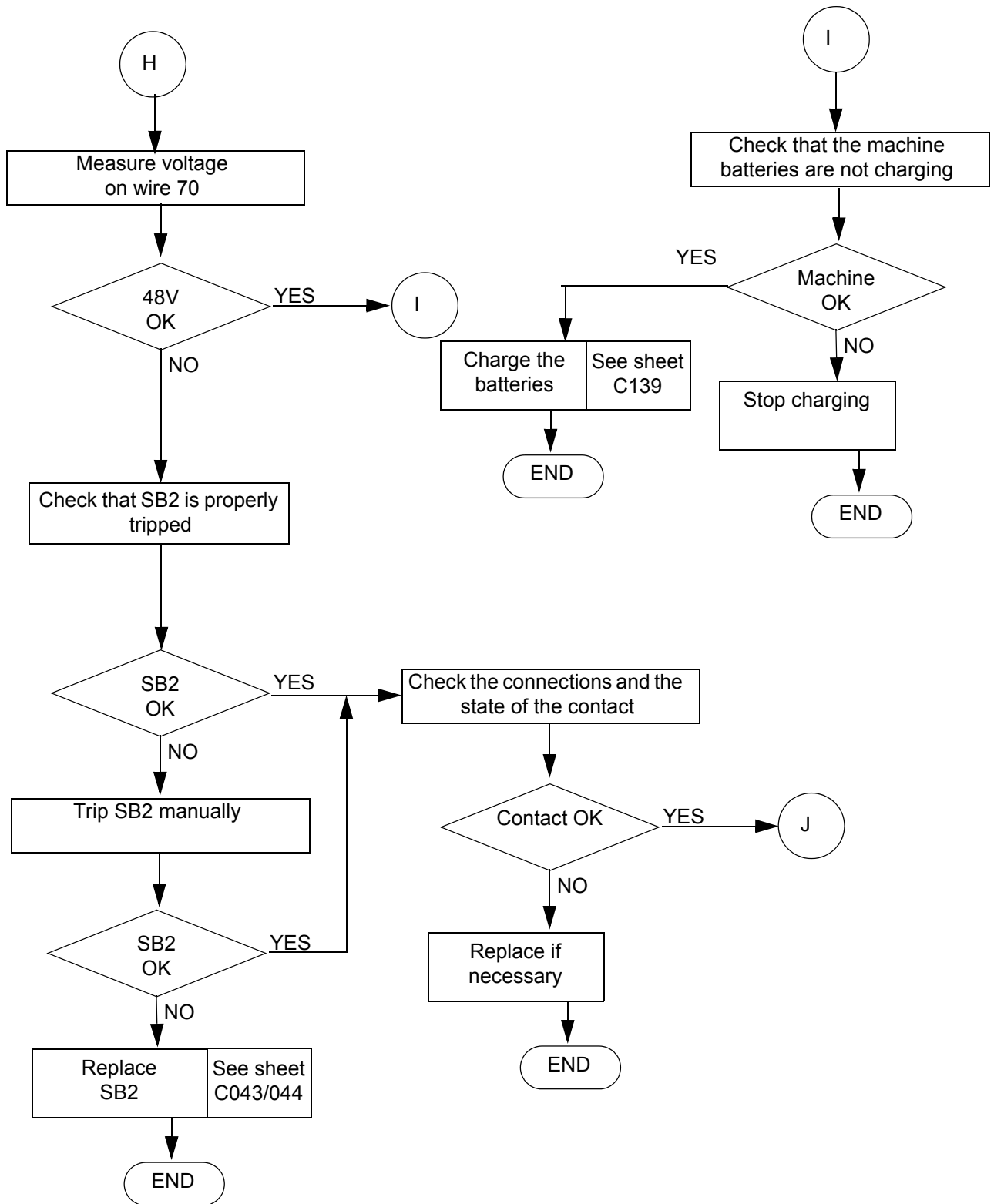

|             |                                |             |
|-------------|--------------------------------|-------------|
| Sheet DP137 | BREAKDOWN DETECTION FLOW CHART | Folio 10/14 |
|             | NO HIGH SPEED                  |             |

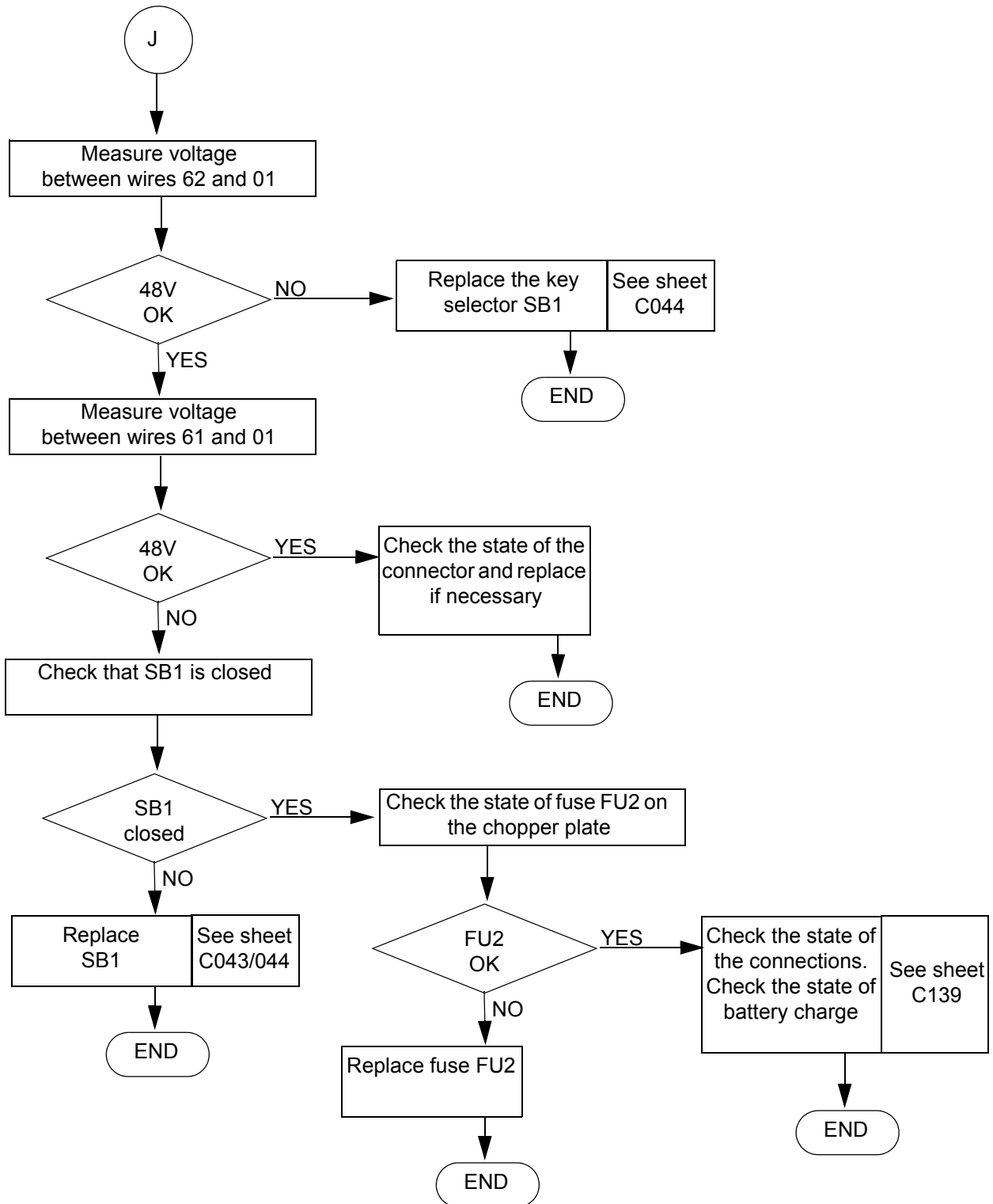

|             |                                |             |
|-------------|--------------------------------|-------------|
| Sheet DP137 | BREAKDOWN DETECTION FLOW CHART | Folio 11/14 |
|             | NO HIGH SPEED                  |             |

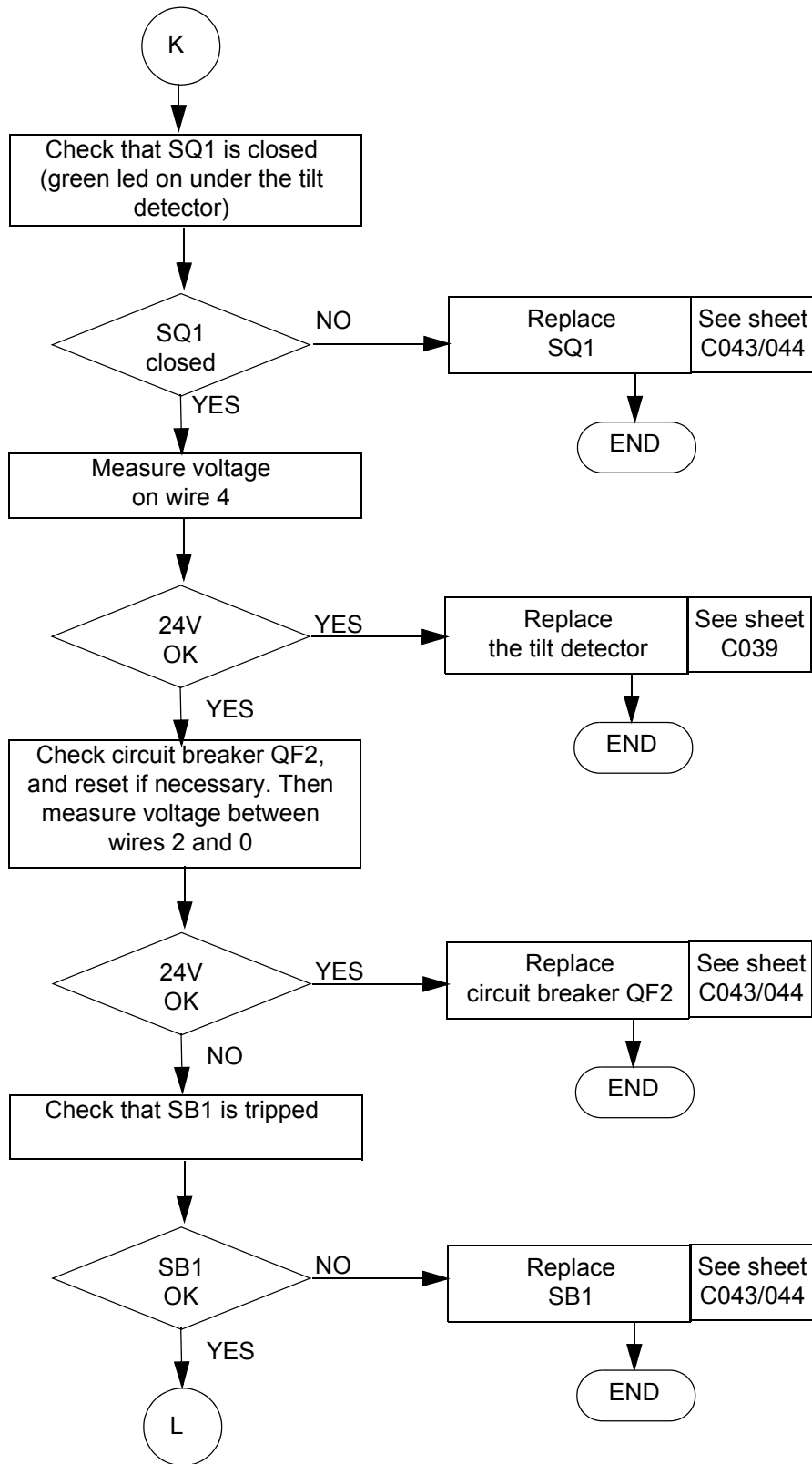

|             |                                |             |
|-------------|--------------------------------|-------------|
| Sheet DP137 | BREAKDOWN DETECTION FLOW CHART | Folio 12/14 |
|             | NO HIGH SPEED                  |             |

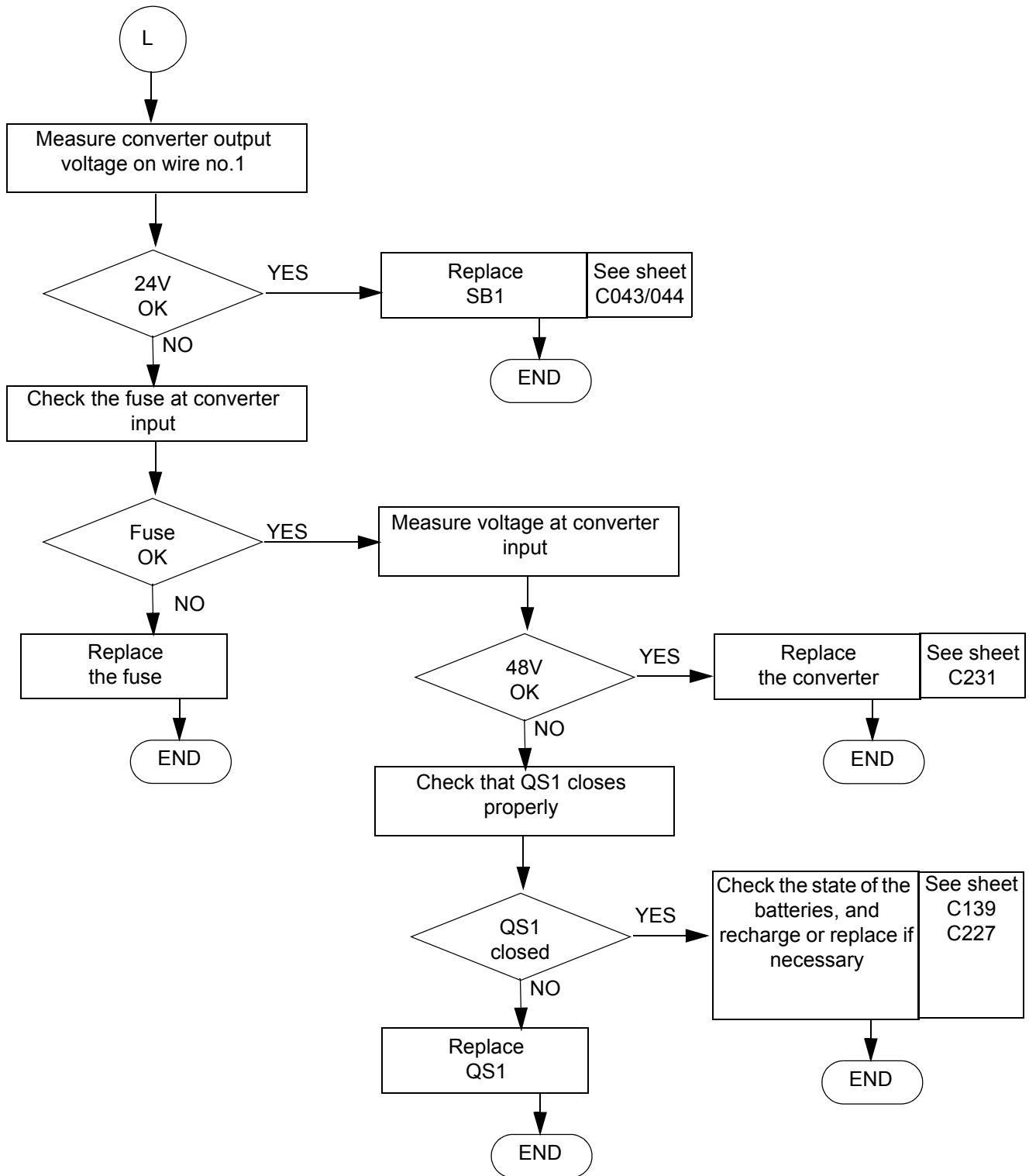

|             |                                |             |
|-------------|--------------------------------|-------------|
| Sheet DP137 | BREAKDOWN DETECTION FLOW CHART | Folio 13/14 |
|             | NO HIGH SPEED                  |             |

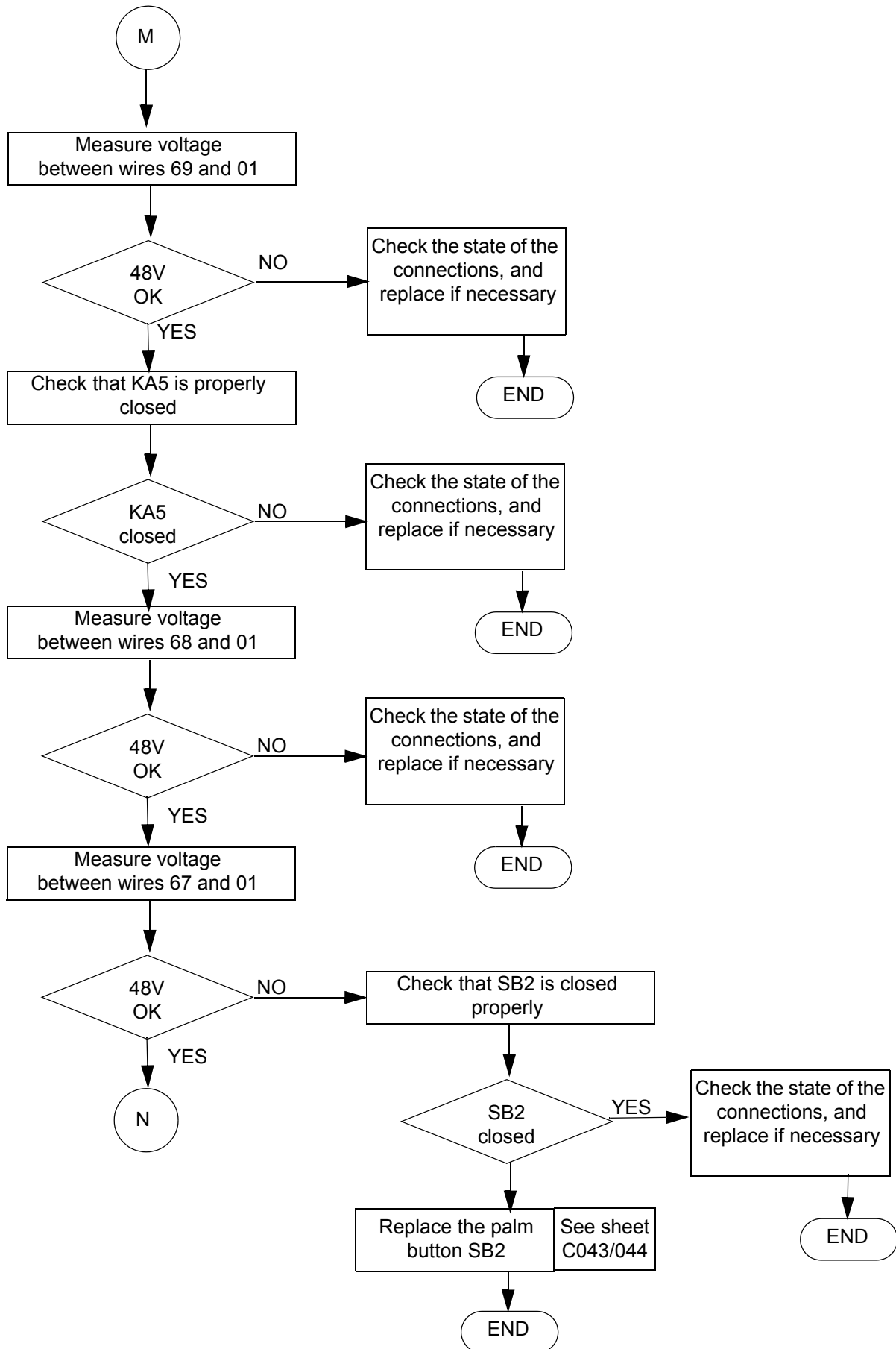

|             |                                |             |
|-------------|--------------------------------|-------------|
| Sheet DP137 | BREAKDOWN DETECTION FLOW CHART | Folio 14/14 |
|             | NO HIGH SPEED                  |             |

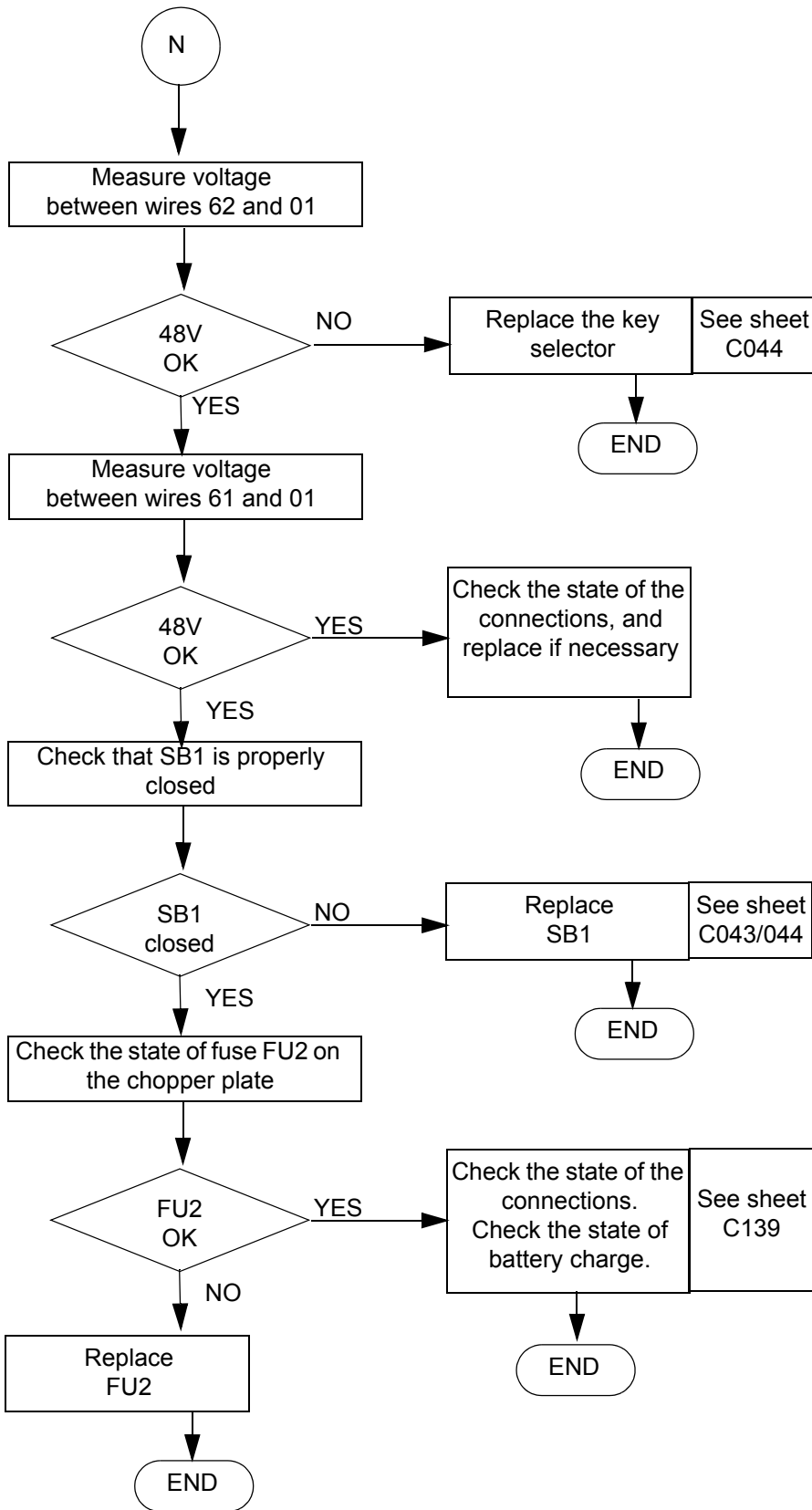

|             |                                |           |
|-------------|--------------------------------|-----------|
| Sheet DP138 | BREAKDOWN DETECTION FLOW CHART | Folio 1/2 |
|             | THE CHARGER DOES NOT CHARGE    |           |

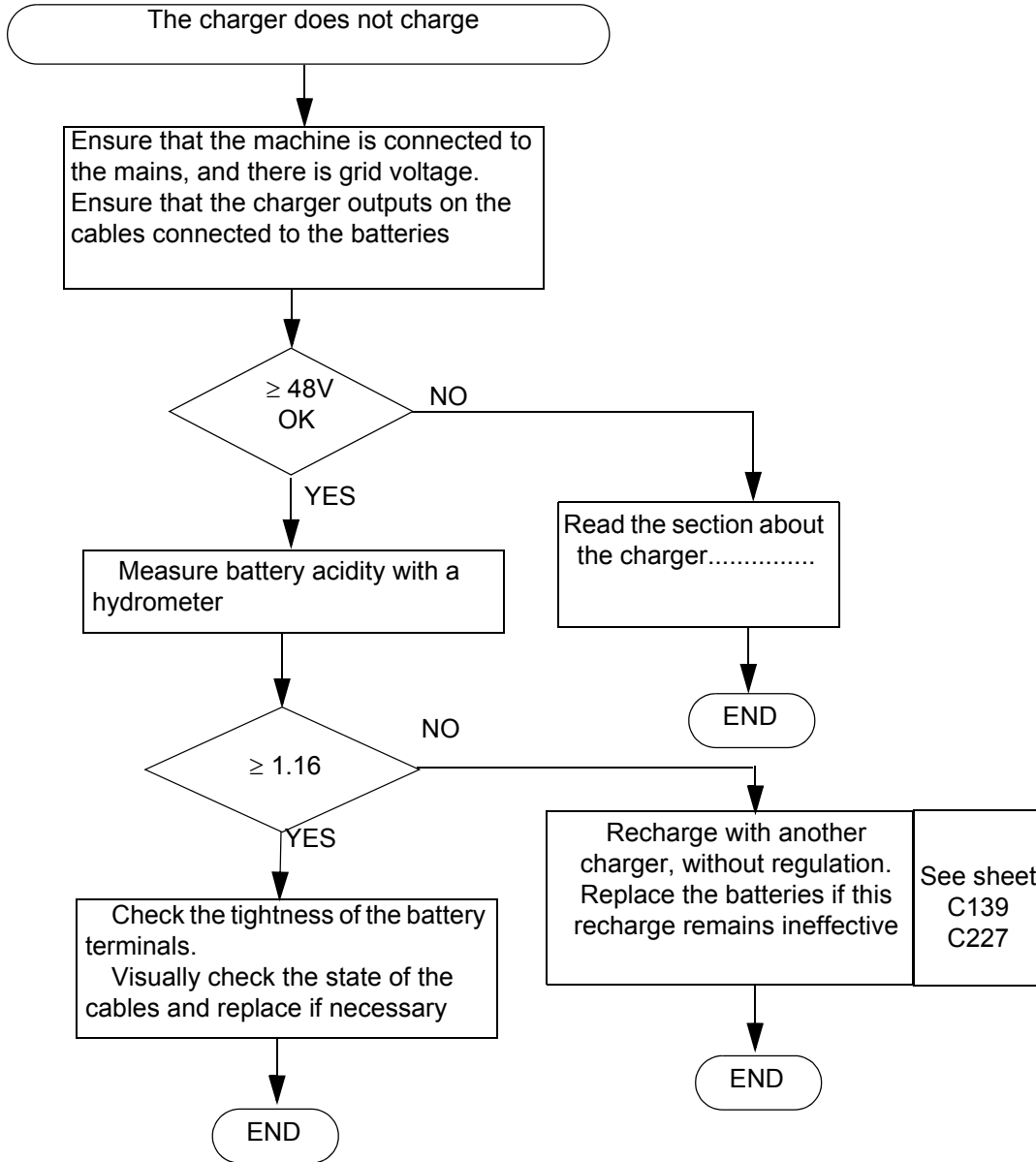

|             |                                |           |
|-------------|--------------------------------|-----------|
| Sheet DP138 | BREAKDOWN DETECTION FLOW CHART | Folio 2/2 |
|             | THE CHARGER DOES NOT CHARGE    |           |

|             |  |           |
|-------------|--|-----------|
| Sheet DP139 | BREAKDOWN DETECTION FLOW CHART             | Folio 1/6 |
|             | NO COMPENSATION MOVEMENT FROM THE PLATFORM |           |

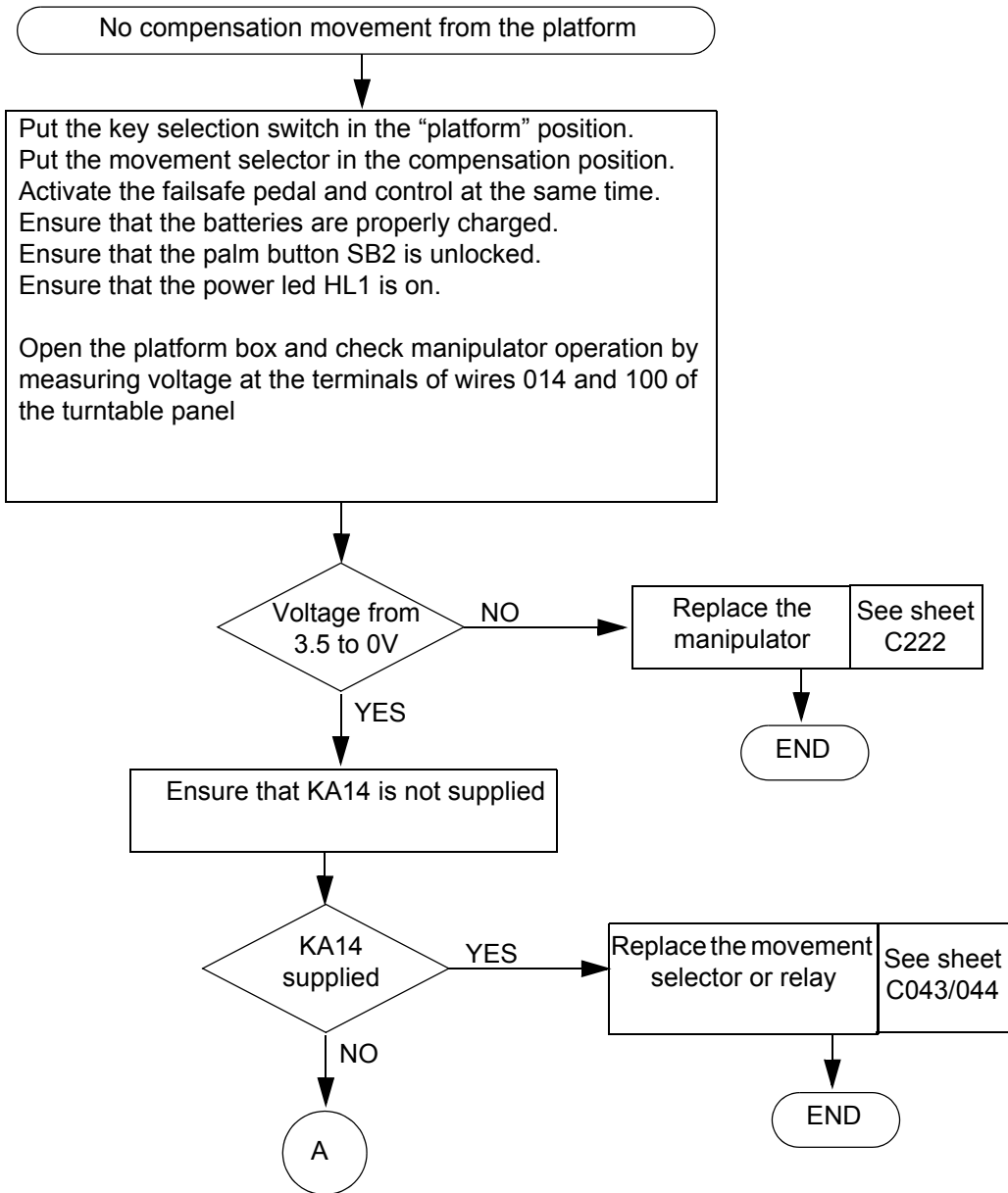

|             |  |           |
|-------------|--|-----------|
| Sheet DP139 | BREAKDOWN DETECTION FLOW CHART             | Folio 2/6 |
|             | NO COMPENSATION MOVEMENT FROM THE PLATFORM |           |

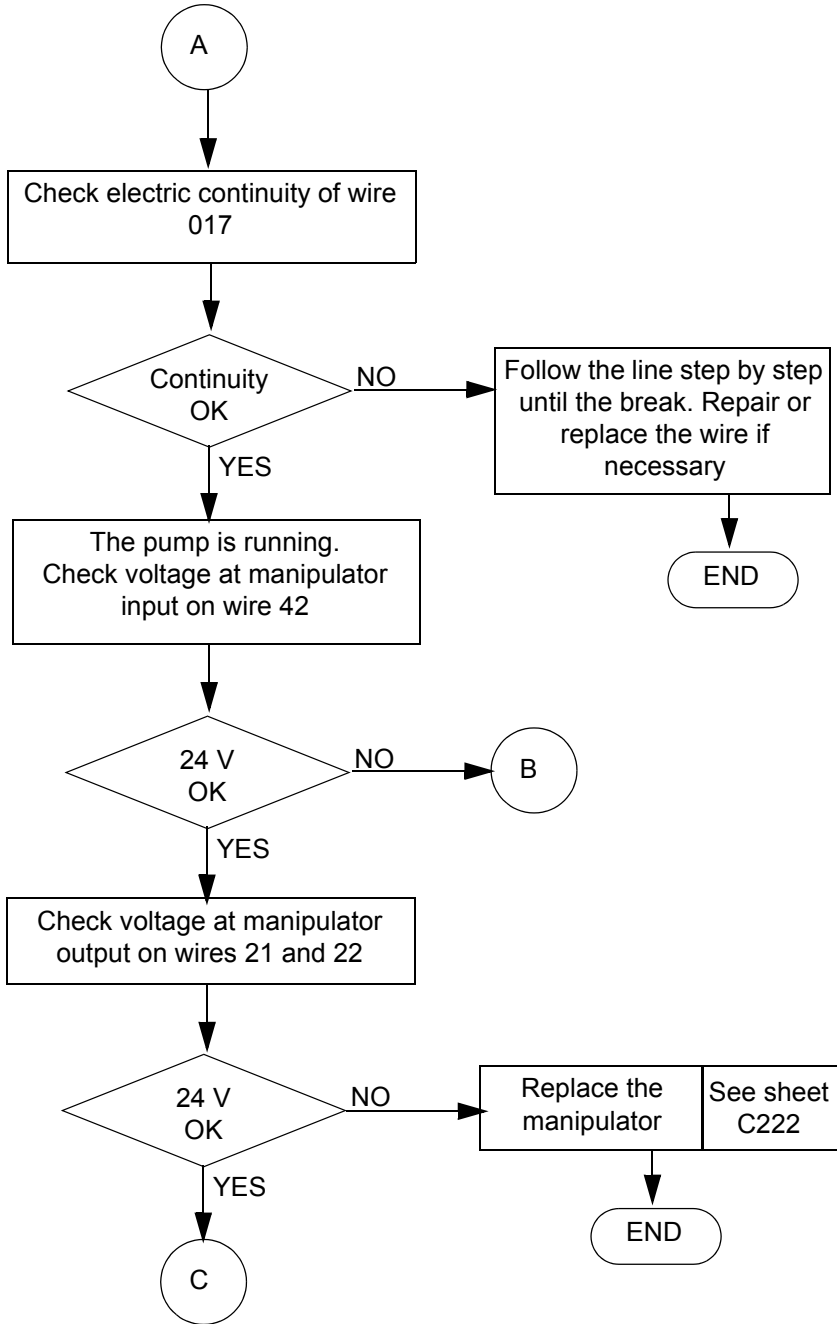

|             |  |           |
|-------------|--|-----------|
| Sheet DP139 | BREAKDOWN DETECTION FLOW CHART             | Folio 3/6 |
|             | NO COMPENSATION MOVEMENT FROM THE PLATFORM |           |

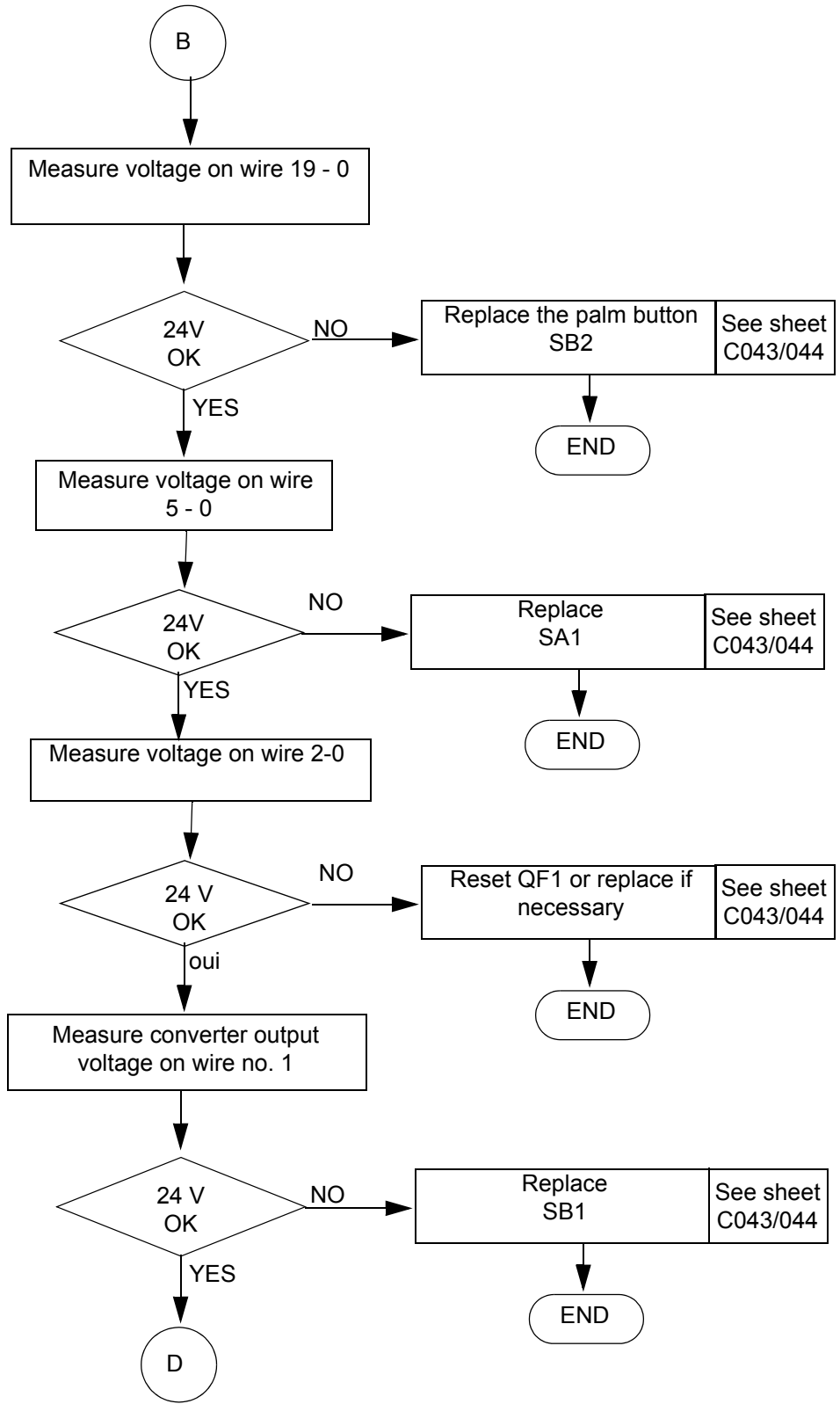

|             |  |           |
|-------------|--|-----------|
| Sheet DP139 | BREAKDOWN DETECTION FLOW CHART             | Folio 4/6 |
|             | NO COMPENSATION MOVEMENT FROM THE PLATFORM |           |

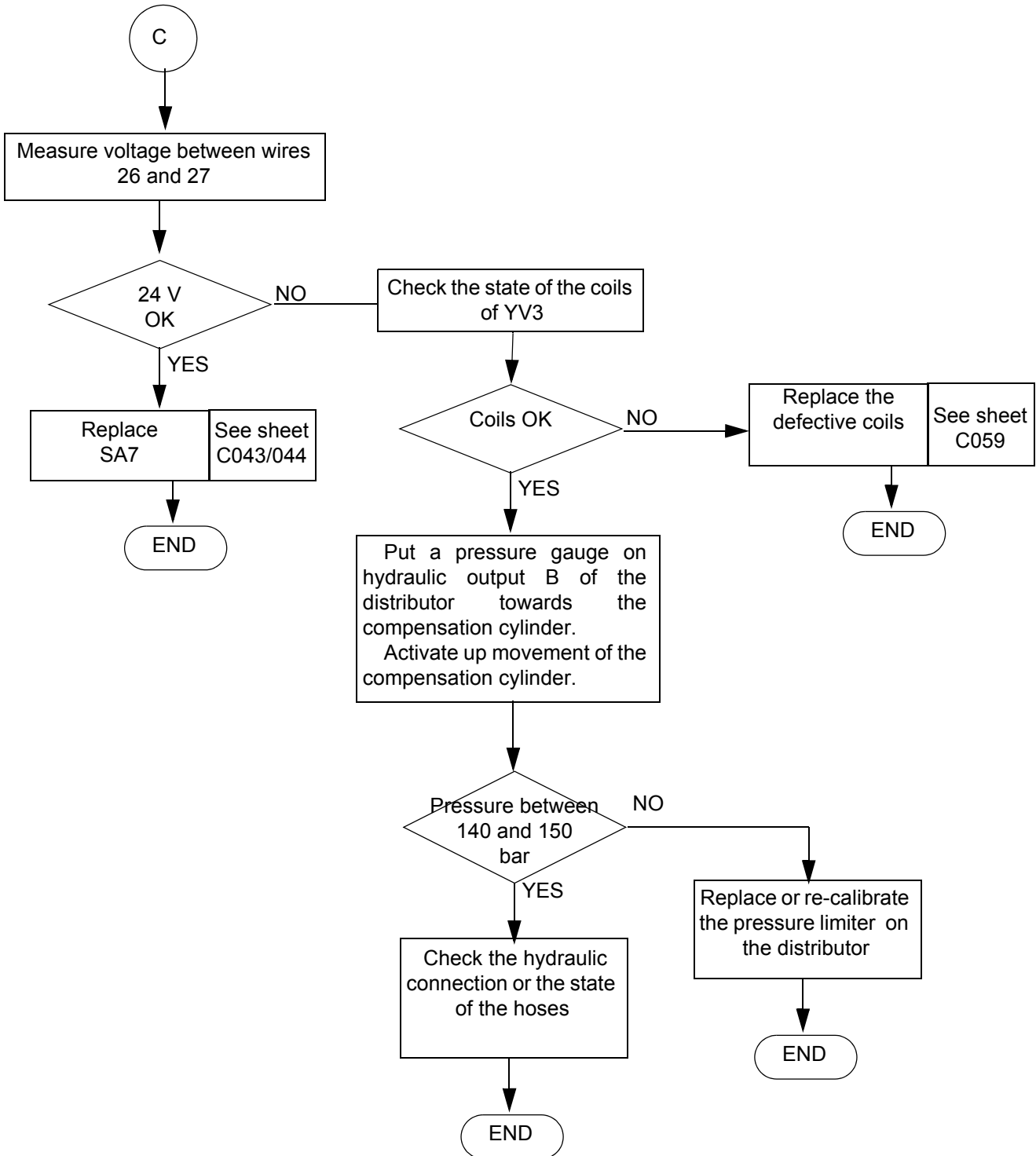

|             |  |           |
|-------------|--|-----------|
| Sheet DP139 | BREAKDOWN DETECTION FLOW CHART             | Folio 5/6 |
|             | NO COMPENSATION MOVEMENT FROM THE PLATFORM |           |

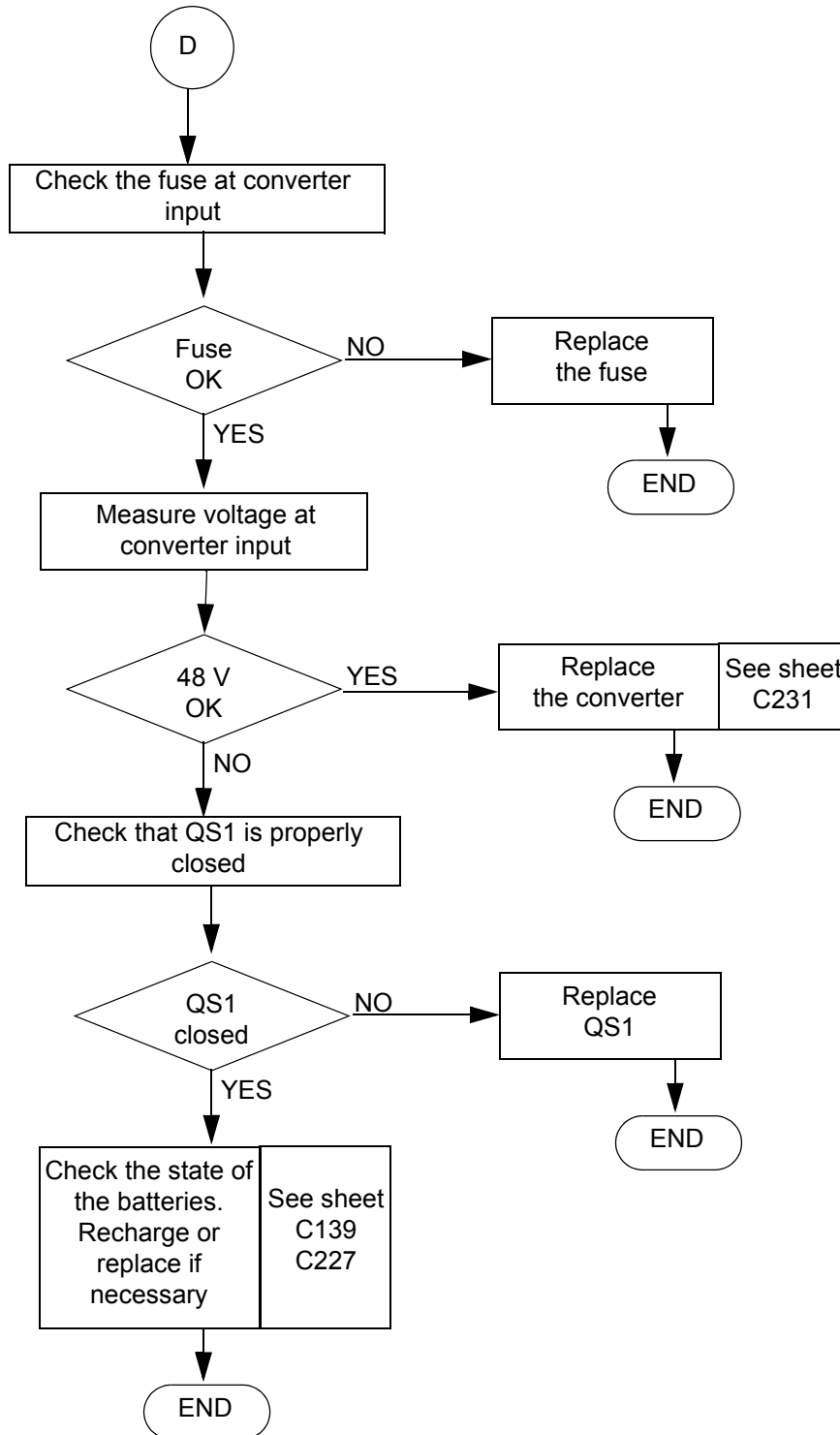

|             |   |           |
|-------------|---|-----------|
| Sheet DP139 | BREAKDOWN DETECTION FLOW CHART                | Folio 6/6 |
|             | NO COMPENSATION MOVEMENT<br>FROM THE PLATFORM |           |

|             |                                       |           |
|-------------|---------------------------------------|-----------|
| Sheet DP140 | BREAKDOWN DETECTION FLOW CHART        | Folio 1/6 |
|             | NO SLEWING MOVEMENT FROM THE PLATFORM |           |

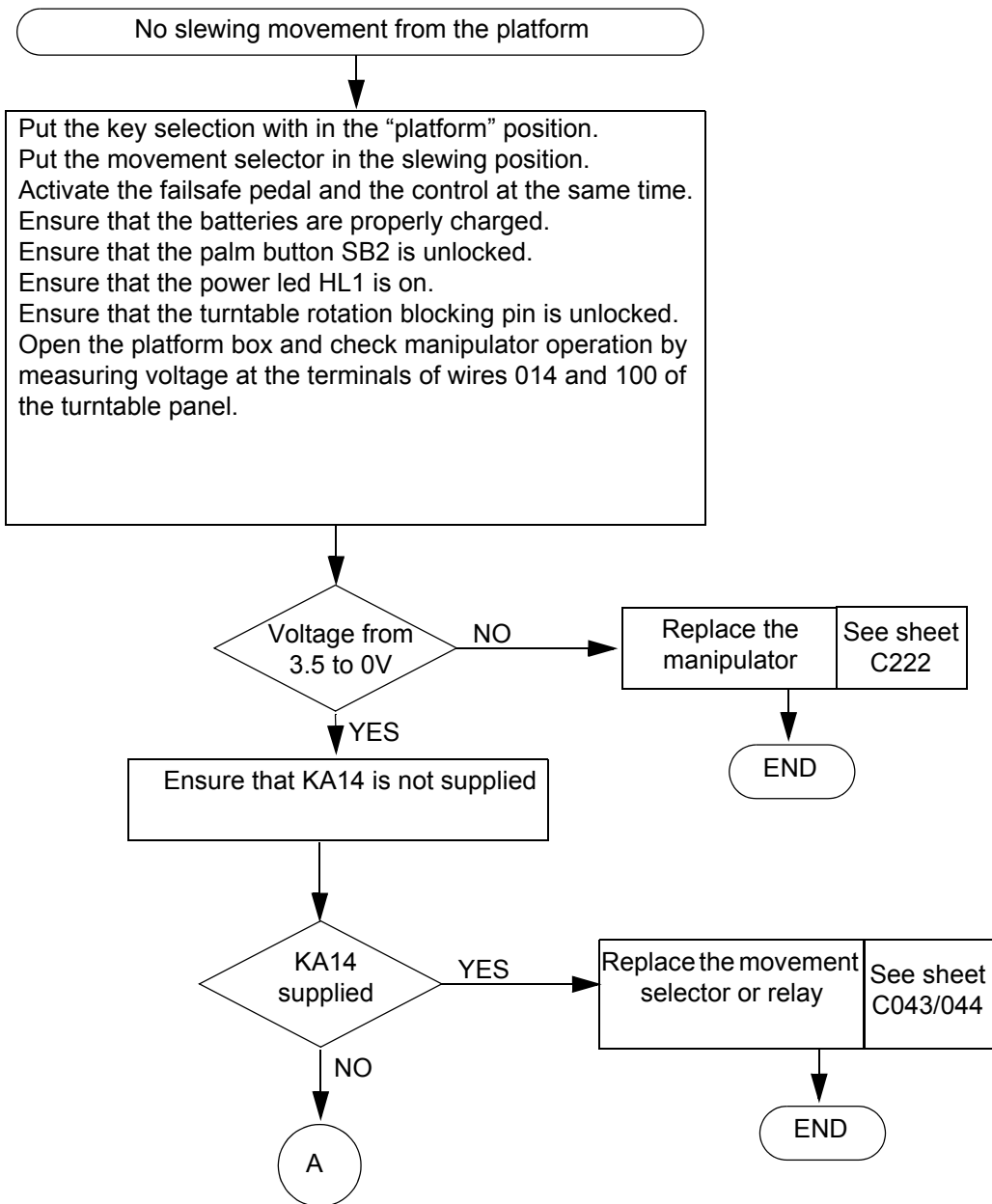

|             |                                       |           |
|-------------|---------------------------------------|-----------|
| Sheet DP140 | BREAKDOWN DETECTION FLOW CHART        | Folio 2/6 |
|             | NO SLEWING MOVEMENT FROM THE PLATFORM |           |

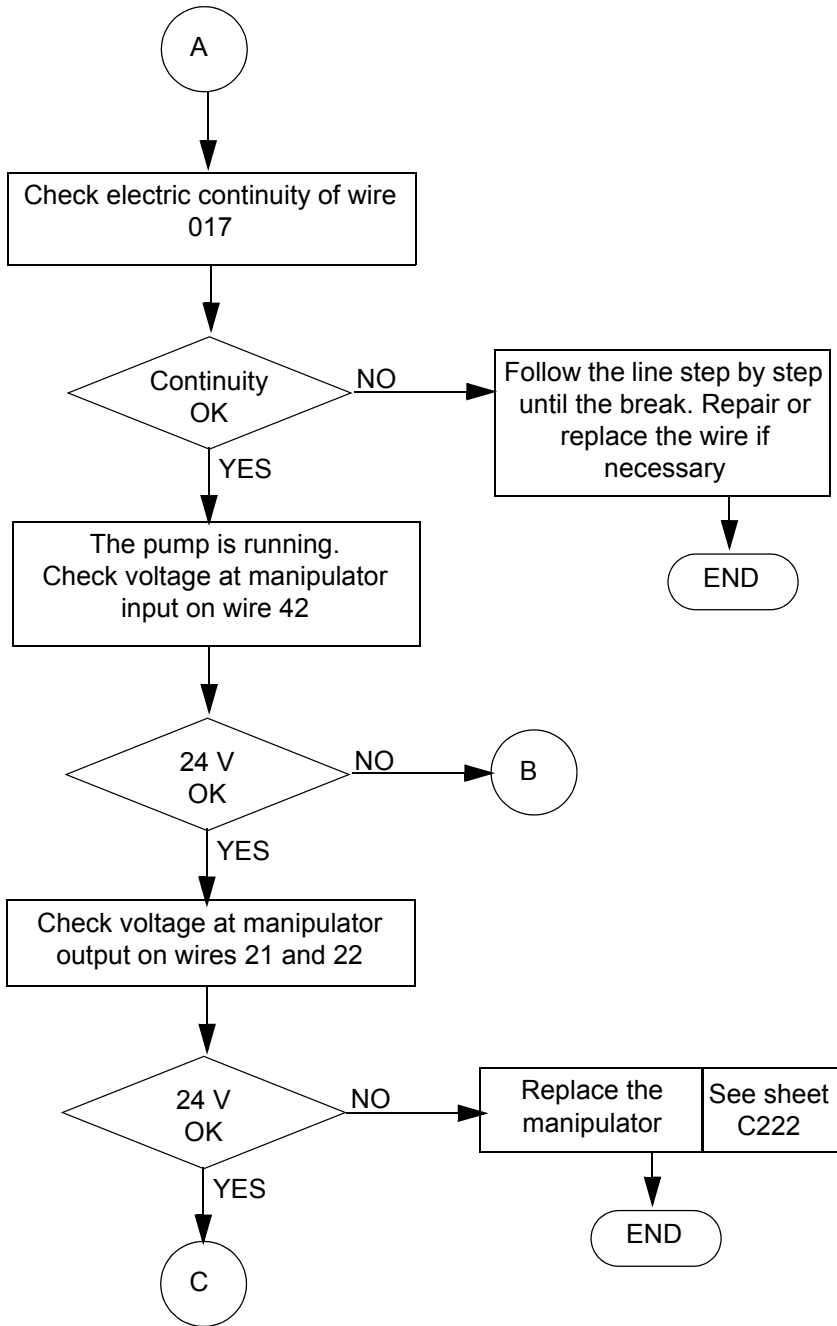

|             |                                       |           |
|-------------|---------------------------------------|-----------|
| Sheet DP140 | BREAKDOWN DETECTION FLOW CHART        | Folio 3/6 |
|             | NO SLEWING MOVEMENT FROM THE PLATFORM |           |

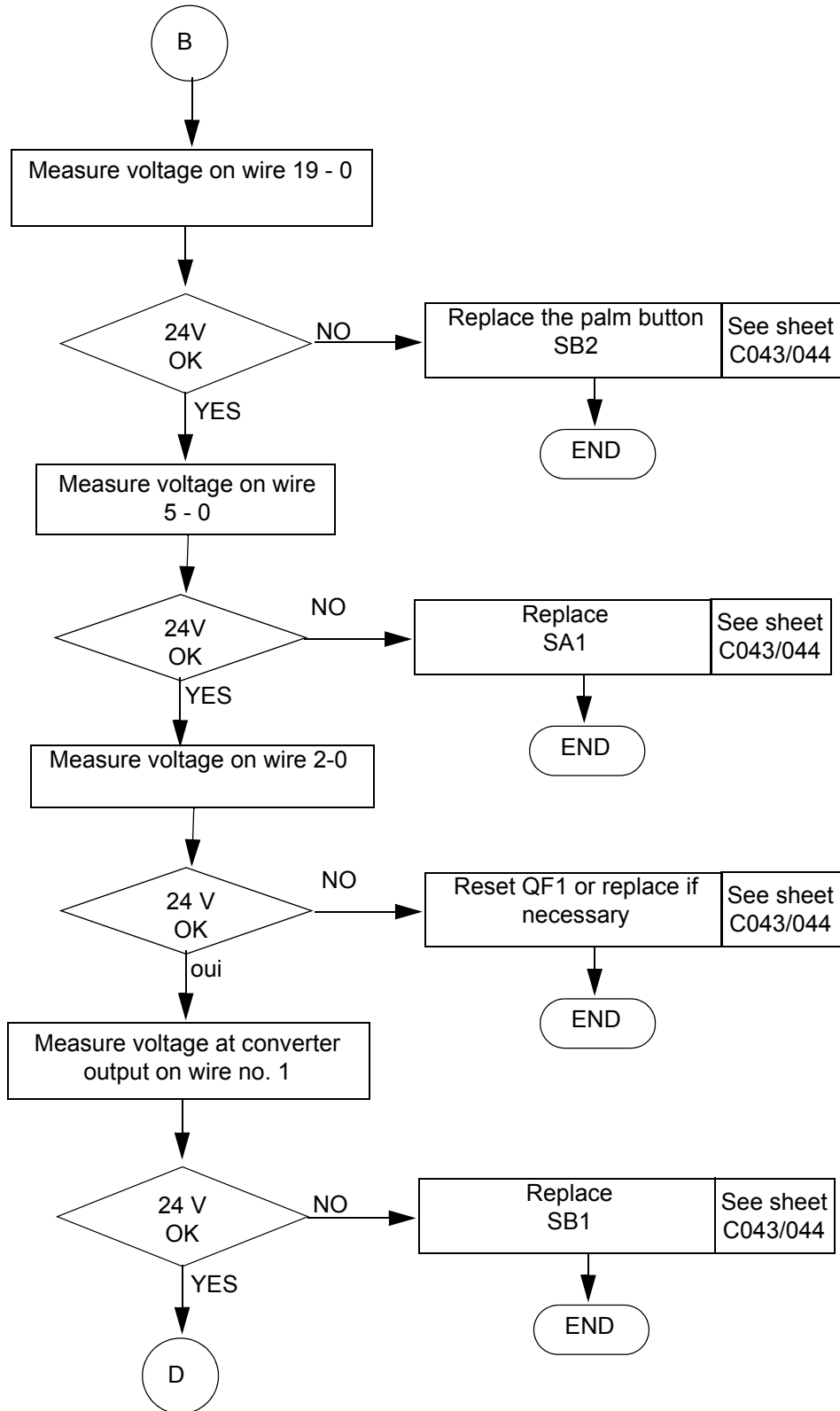

|             |                                       |           |
|-------------|---------------------------------------|-----------|
| Sheet DP140 | BREAKDOWN DETECTION FLOW CHART        | Folio 4/6 |
|             | NO SLEWING MOVEMENT FROM THE PLATFORM |           |

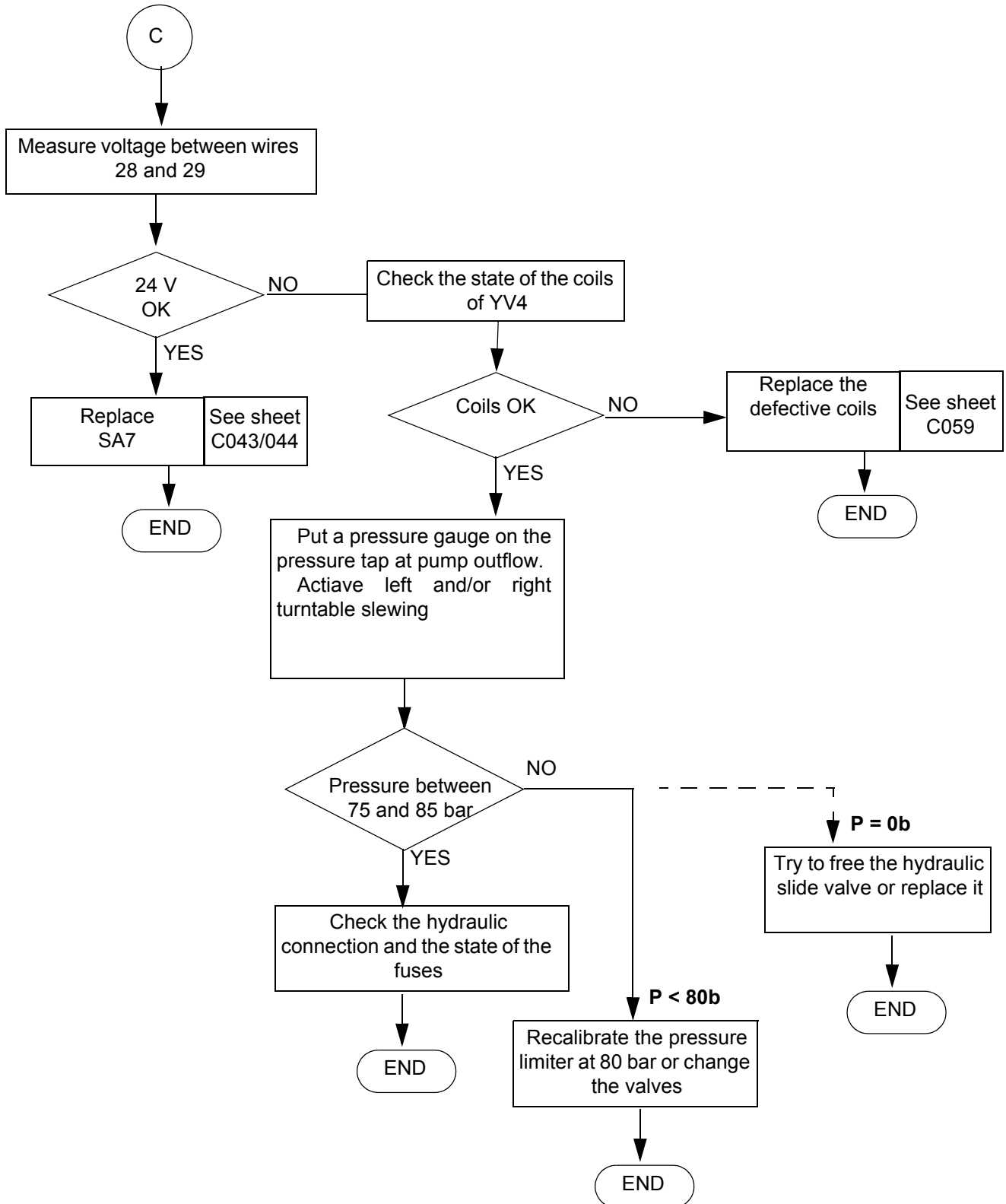

|             |                                       |           |
|-------------|---------------------------------------|-----------|
| Sheet DP140 | BREAKDOWN DETECTION FLOW CHART        | Folio 5/6 |
|             | NO SLEWING MOVEMENT FROM THE PLATFORM |           |

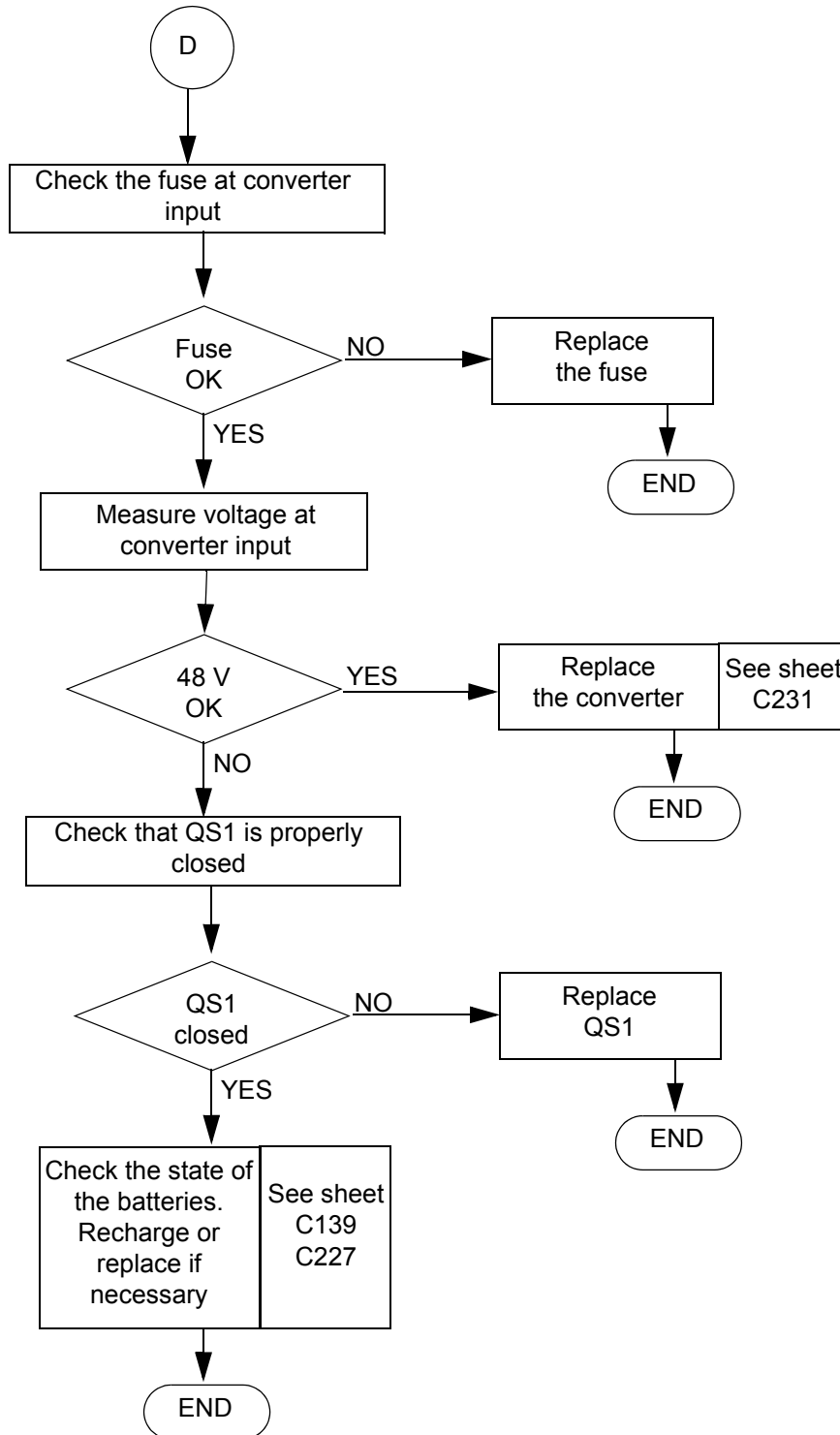

|             |  |           |
|-------------|--|-----------|
| Sheet DP140 | BREAKDOWN DETECTION FLOW CHART           | Folio 6/6 |
|             | NO SLEWING MOVEMENT<br>FROM THE PLATFORM |           |

|             |   |           |
|-------------|---|-----------|
| Sheet DP141 | BREAKDOWN DETECTION FLOW CHART            | Folio 1/6 |
|             | NO ARM LIFTING MOVEMENT FROM THE PLATFORM |           |

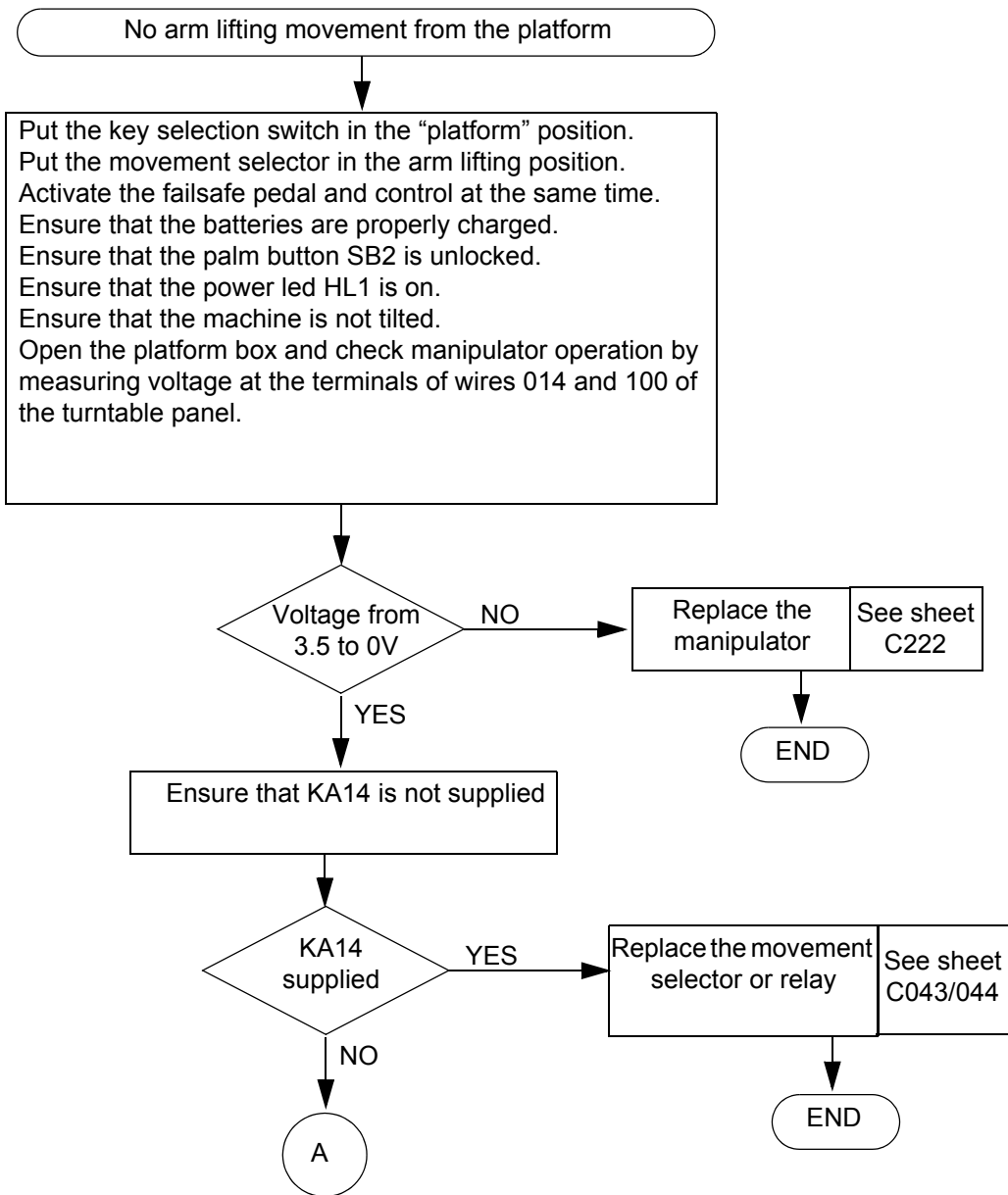

|             |   |           |
|-------------|---|-----------|
| Sheet DP141 | BREAKDOWN DETECTION FLOW CHART            | Folio 2/6 |
|             | NO ARM LIFTING MOVEMENT FROM THE PLATFORM |           |

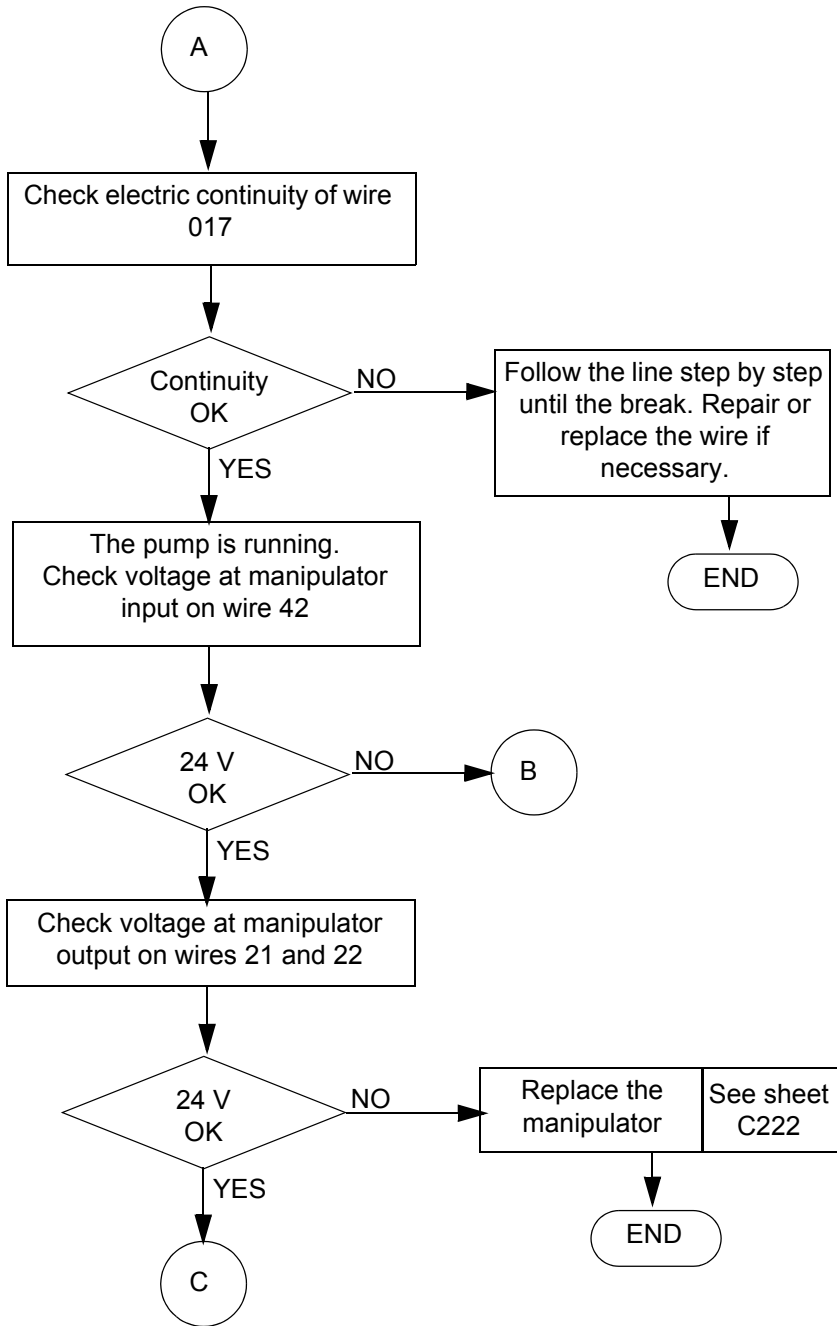

|             |   |           |
|-------------|---|-----------|
| Sheet DP141 | BREAKDOWN DETECTION FLOW CHART            | Folio 3/6 |
|             | NO ARM LIFTING MOVEMENT FROM THE PLATFORM |           |

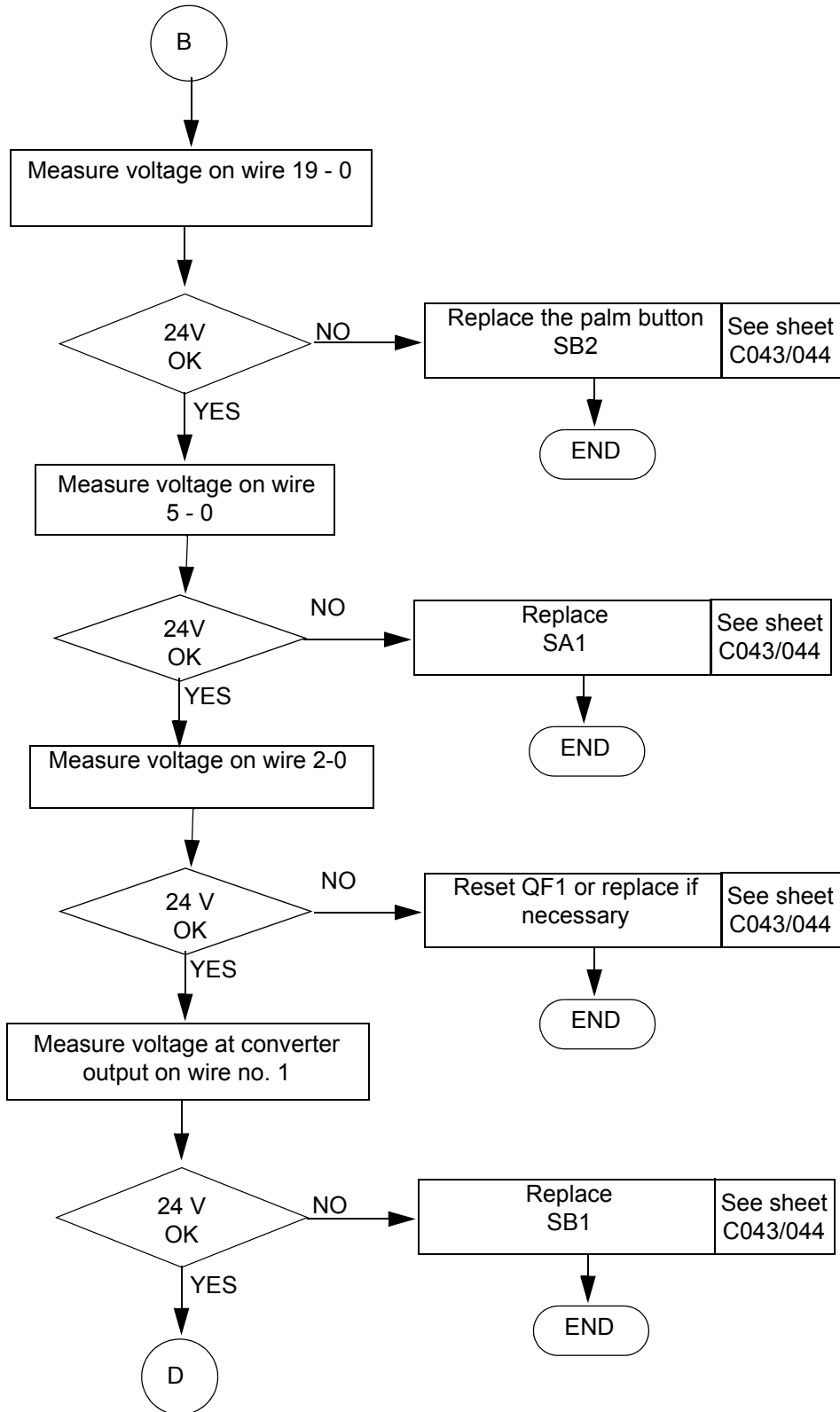

|             |   |           |
|-------------|---|-----------|
| Sheet DP141 | BREAKDOWN DETECTION FLOW CHART            | Folio 4/6 |
|             | NO ARM LIFTING MOVEMENT FROM THE PLATFORM |           |

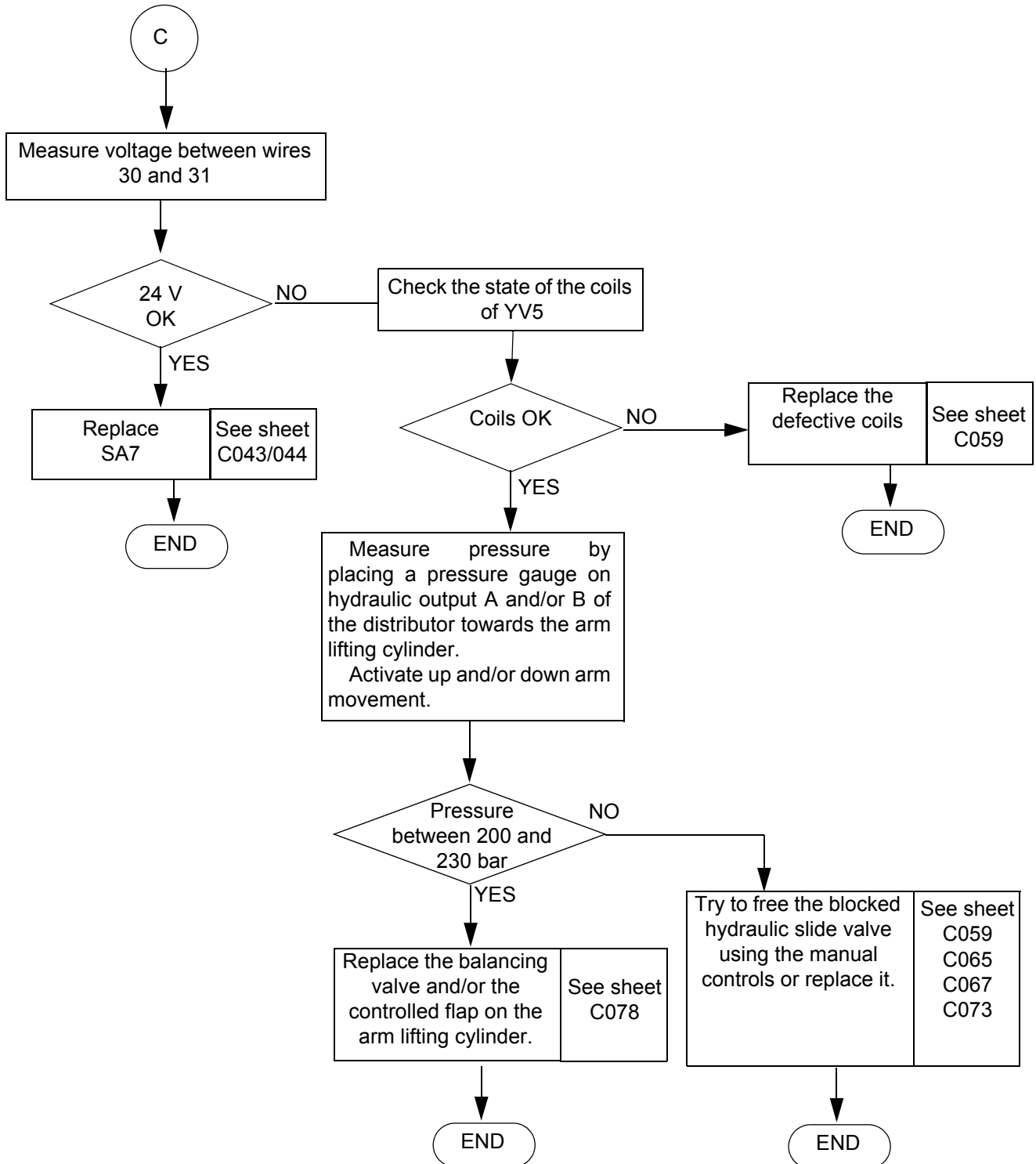

|             |   |           |
|-------------|---|-----------|
| Sheet DP141 | BREAKDOWN DETECTION FLOW CHART            | Folio 5/6 |
|             | NO ARM LIFTING MOVEMENT FROM THE PLATFORM |           |

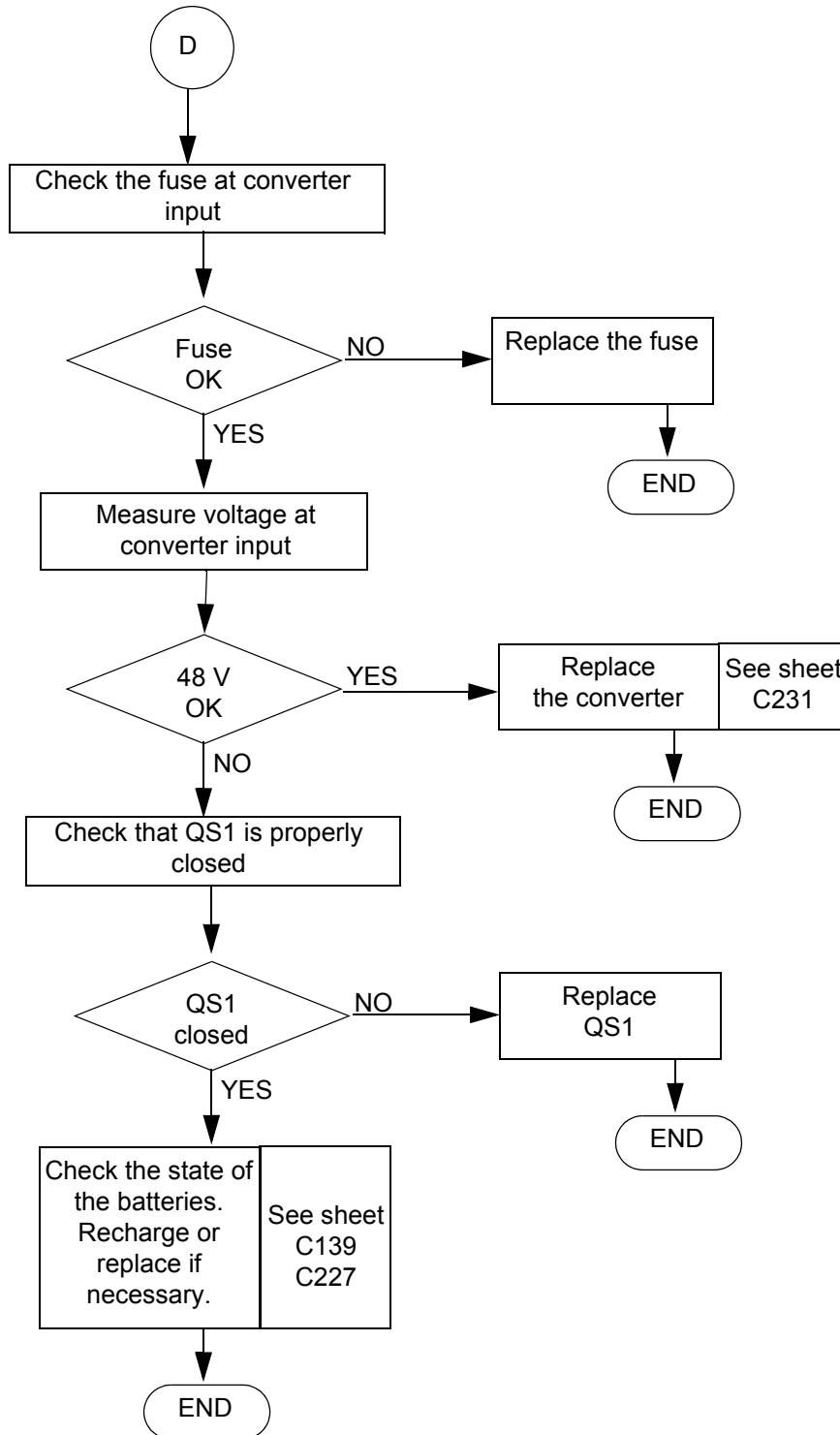

|             |  |           |
|-------------|--|-----------|
| Sheet DP141 | BREAKDOWN DETECTION FLOW CHART               | Folio 6/6 |
|             | NO ARM LIFTING MOVEMENT<br>FROM THE PLATFORM |           |

|             |  |           |
|-------------|--|-----------|
| Sheet DP142 | BREAKDOWN DETECTION FLOW CHART             | Folio 1/6 |
|             | NO BOOM LIFTING MOVEMENT FROM THE PLATFORM |           |

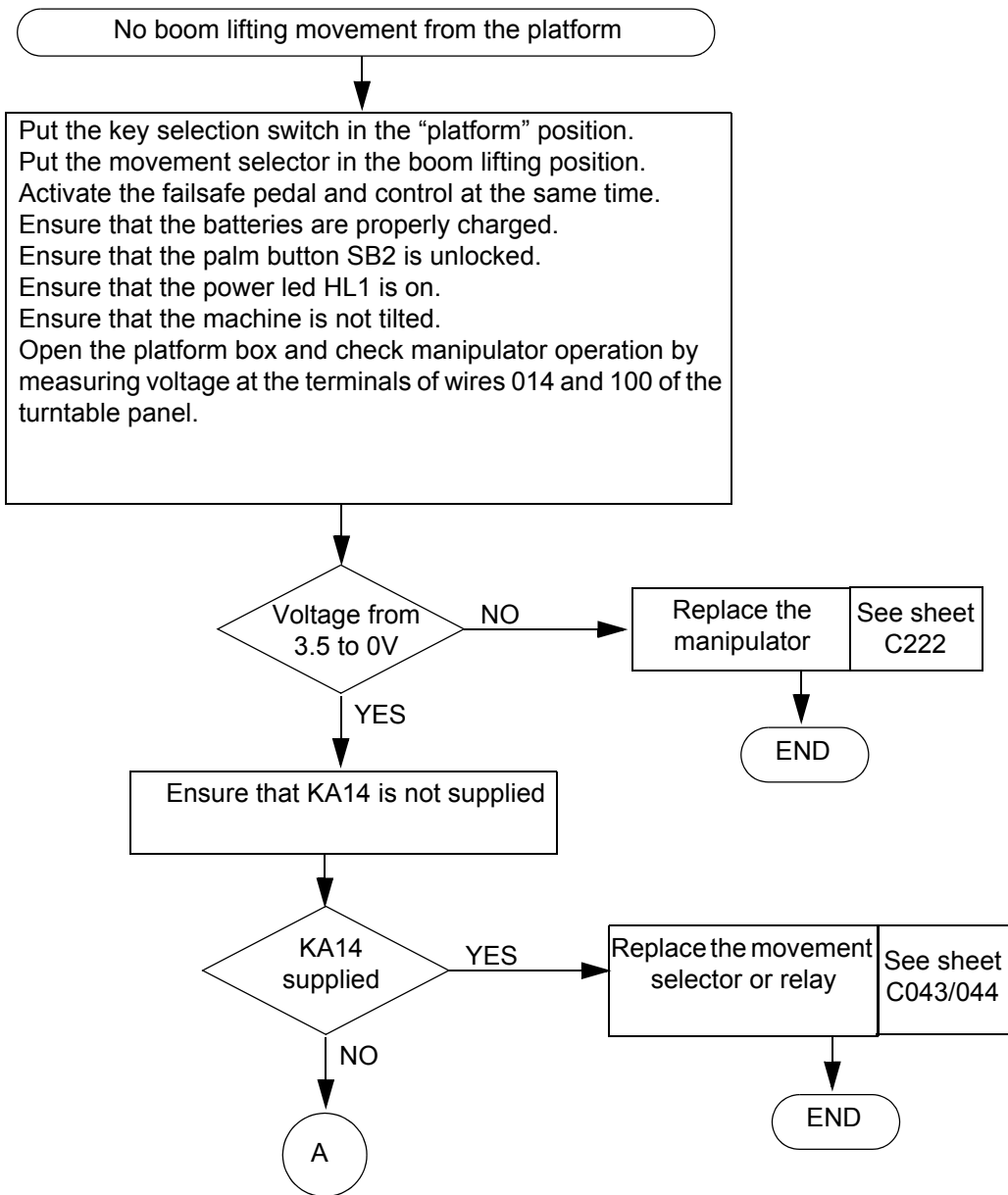

|             |  |           |
|-------------|--|-----------|
| Sheet DP142 | BREAKDOWN DETECTION FLOW CHART             | Folio 2/6 |
|             | NO BOOM LIFTING MOVEMENT FROM THE PLATFORM |           |

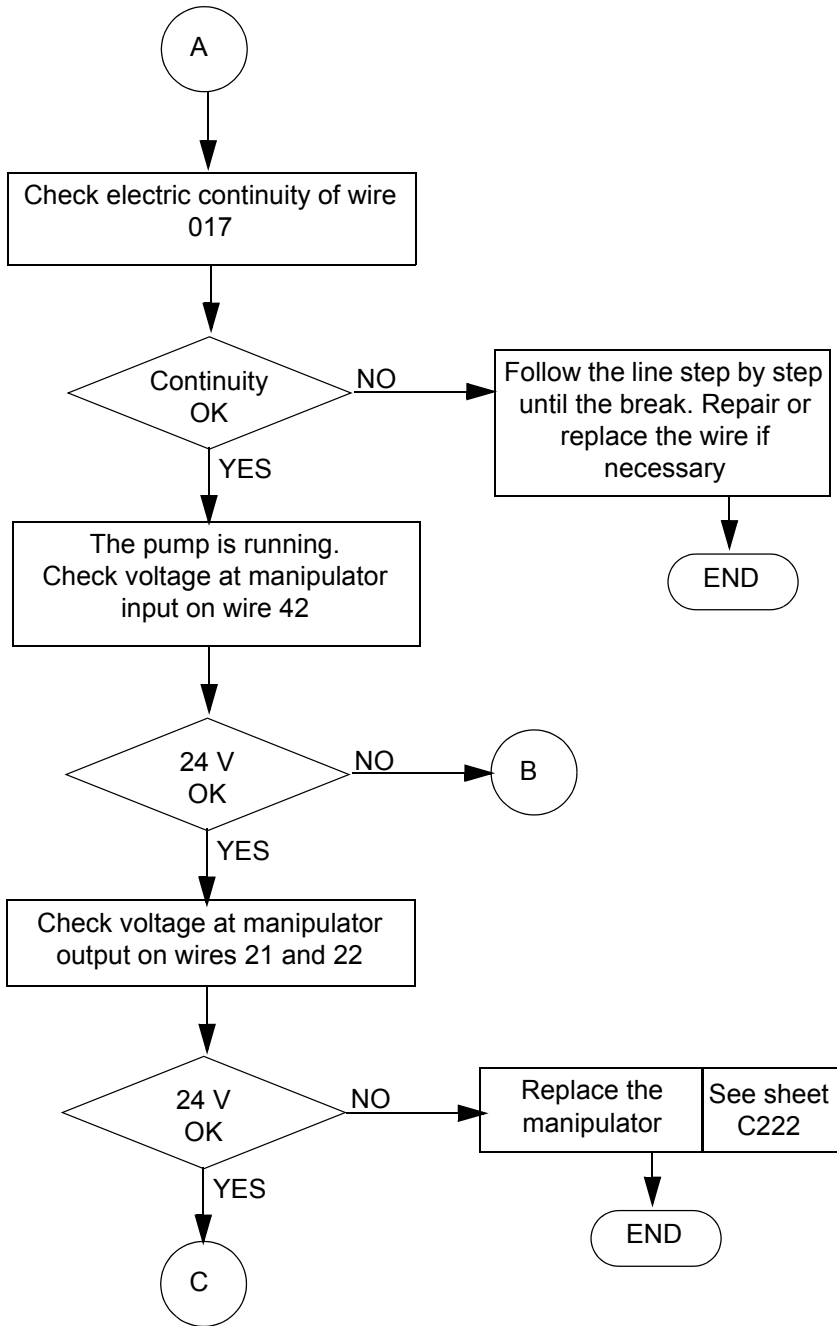

|             |  |           |
|-------------|--|-----------|
| Sheet DP142 | BREAKDOWN DETECTION FLOW CHART             | Folio 3/6 |
|             | NO BOOM LIFTING MOVEMENT FROM THE PLATFORM |           |

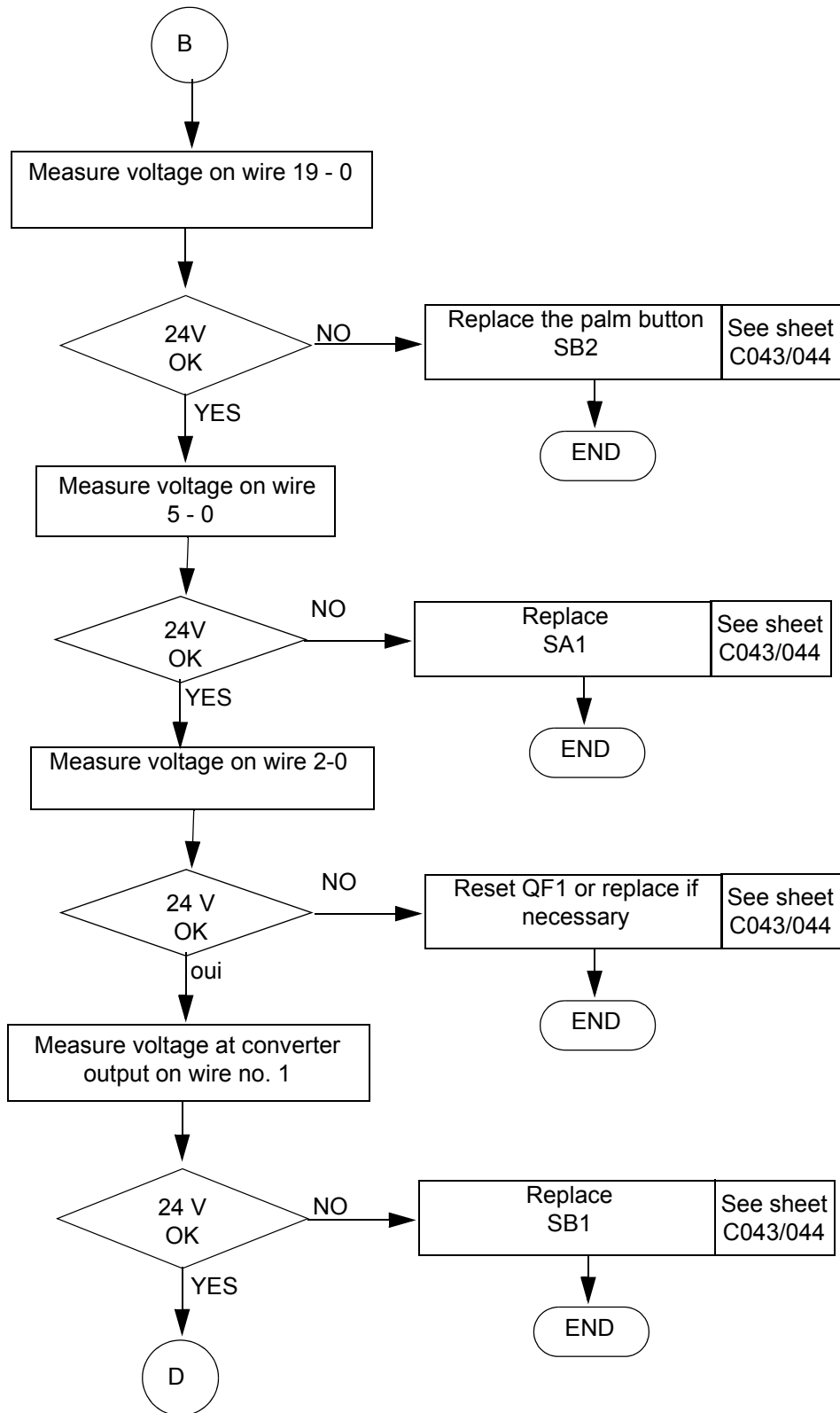

|             |  |           |
|-------------|--|-----------|
| Sheet DP142 | BREAKDOWN DETECTION FLOW CHART             | Folio 4/6 |
|             | NO BOOM LIFTING MOVEMENT FROM THE PLATFORM |           |

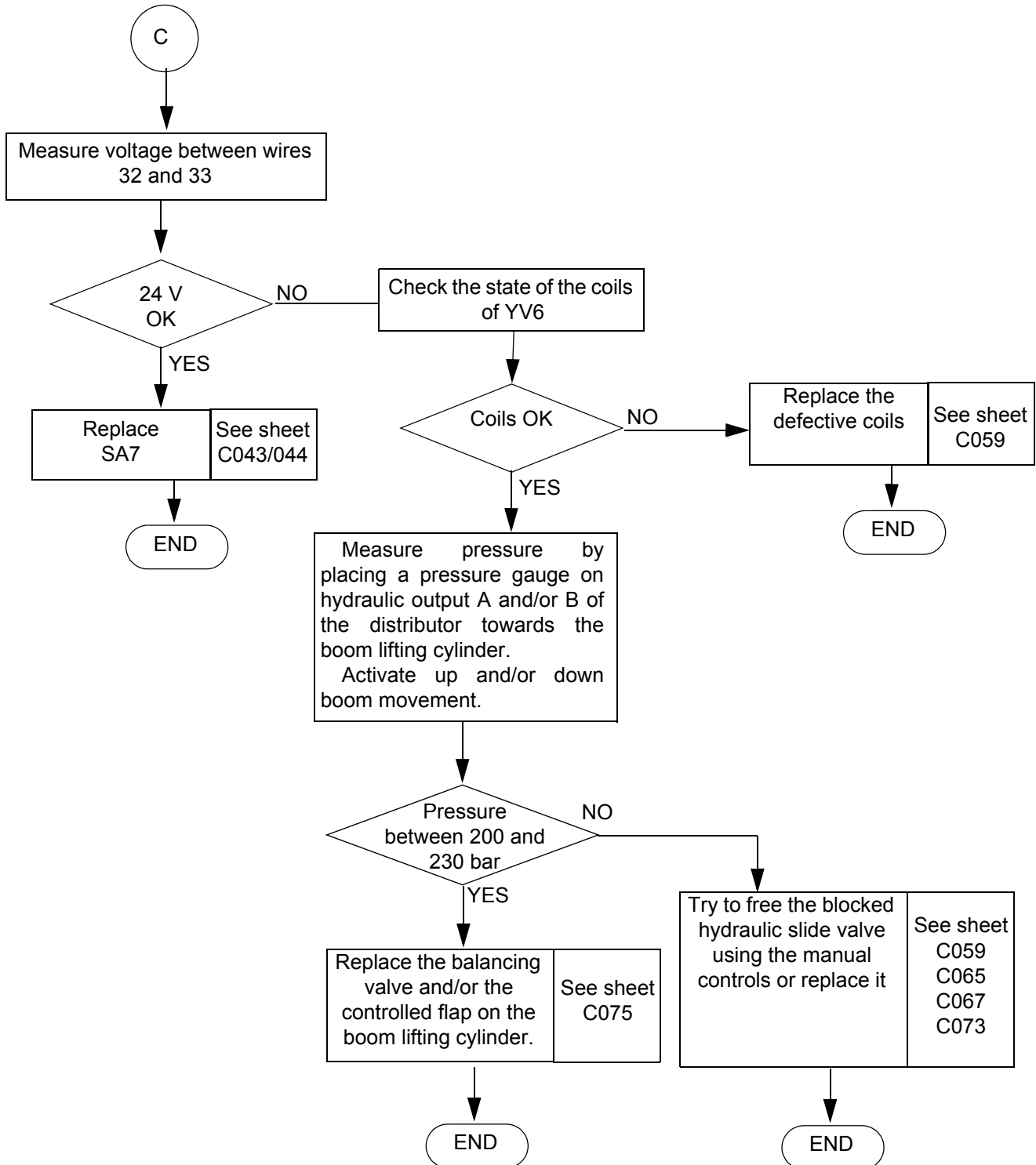

|             |  |           |
|-------------|--|-----------|
| Sheet DP142 | BREAKDOWN DETECTION FLOW CHART             | Folio 5/6 |
|             | NO BOOM LIFTING MOVEMENT FROM THE PLATFORM |           |

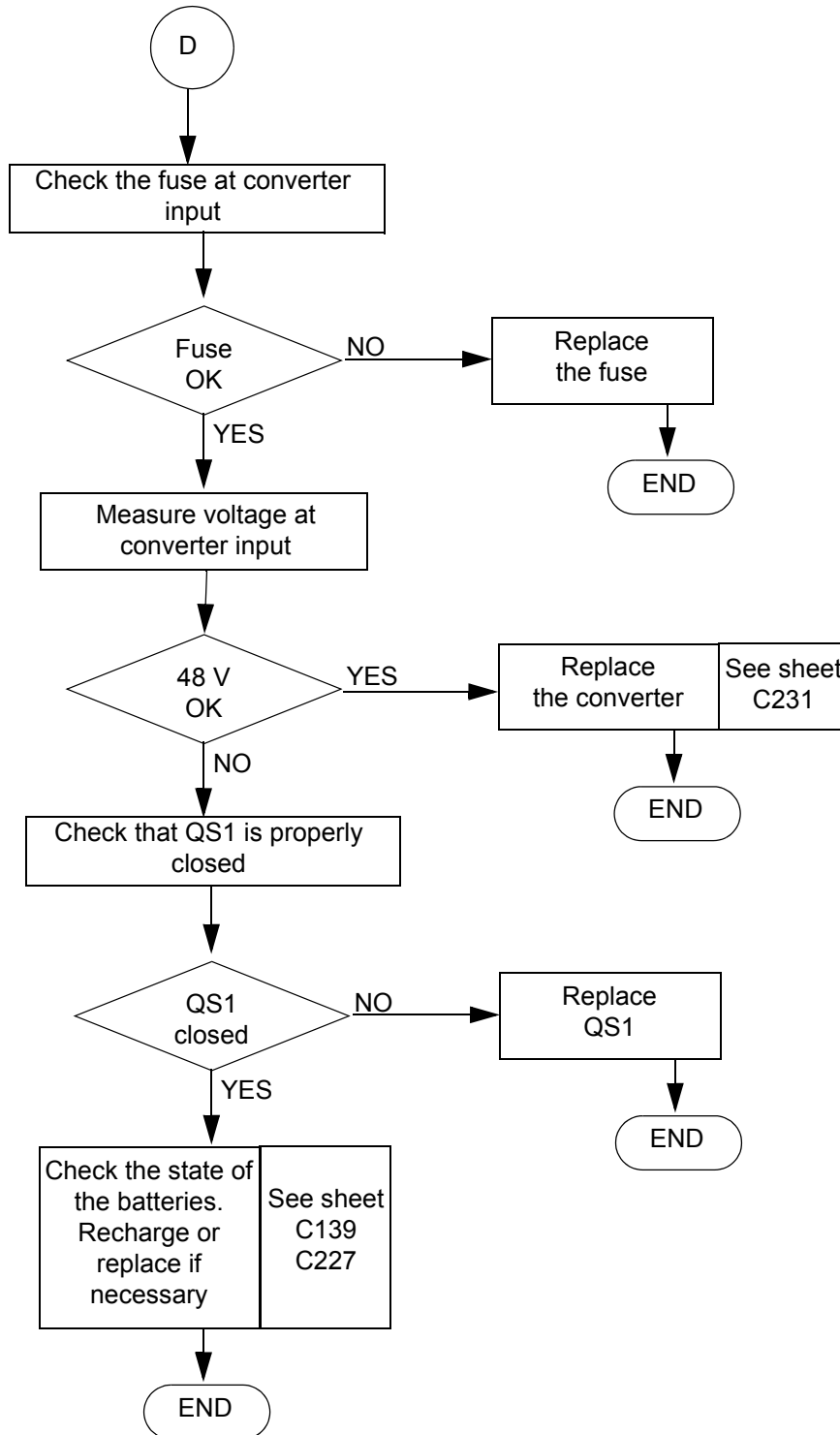

|             |   |           |
|-------------|---|-----------|
| Sheet DP142 | BREAKDOWN DETECTION FLOW CHART                | Folio 6/6 |
|             | NO BOOM LIFTING MOVEMENT<br>FROM THE PLATFORM |           |

|             |   |           |
|-------------|---|-----------|
| Sheet DP143 | BREAKDOWN DETECTION FLOW CHART            | Folio 1/6 |
|             | NO TELESCOPING MOVEMENT FROM THE PLATFORM |           |

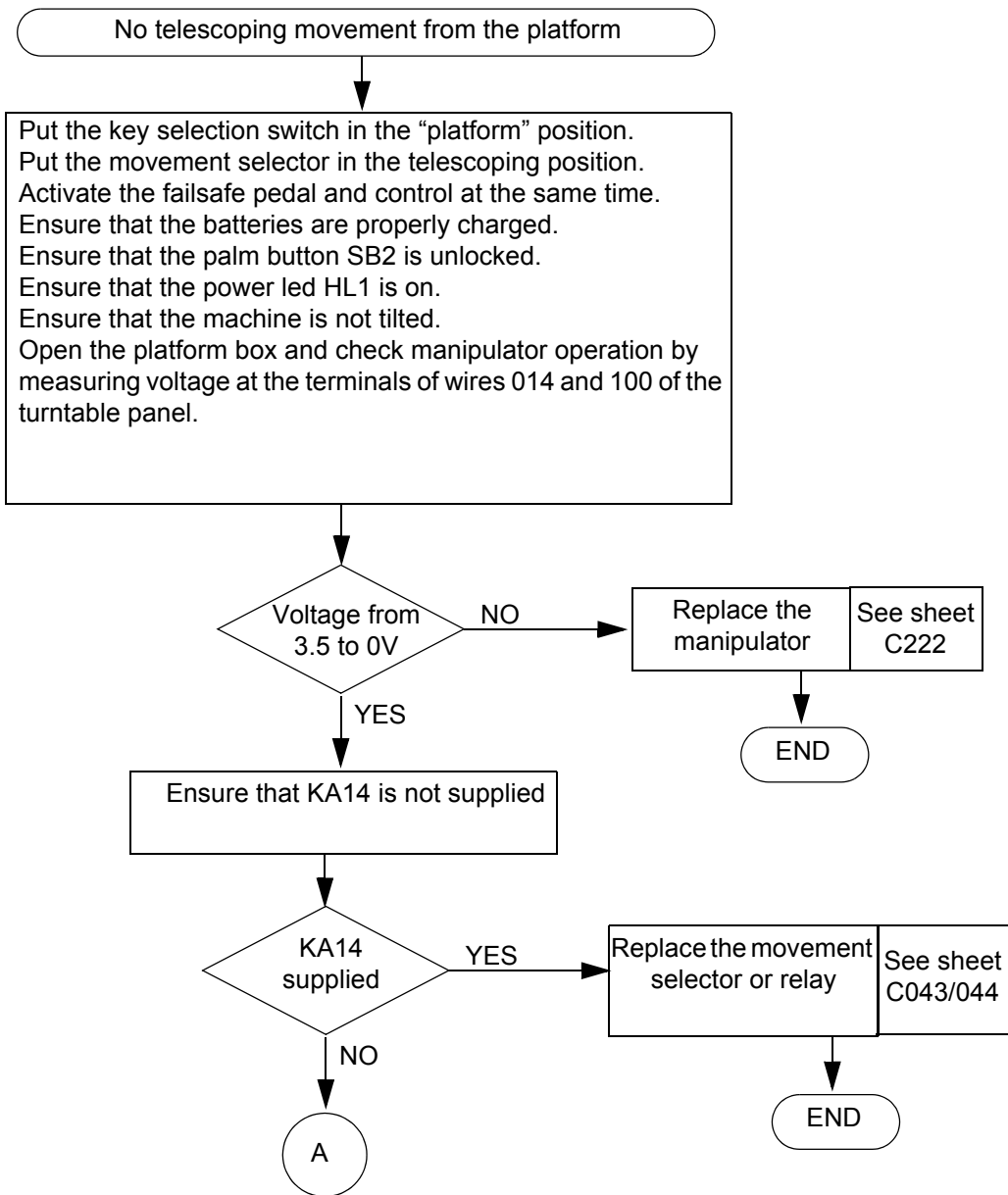

|             |   |           |
|-------------|---|-----------|
| Sheet DP143 | BREAKDOWN DETECTION FLOW CHART            | Folio 2/6 |
|             | NO TELESCOPING MOVEMENT FROM THE PLATFORM |           |

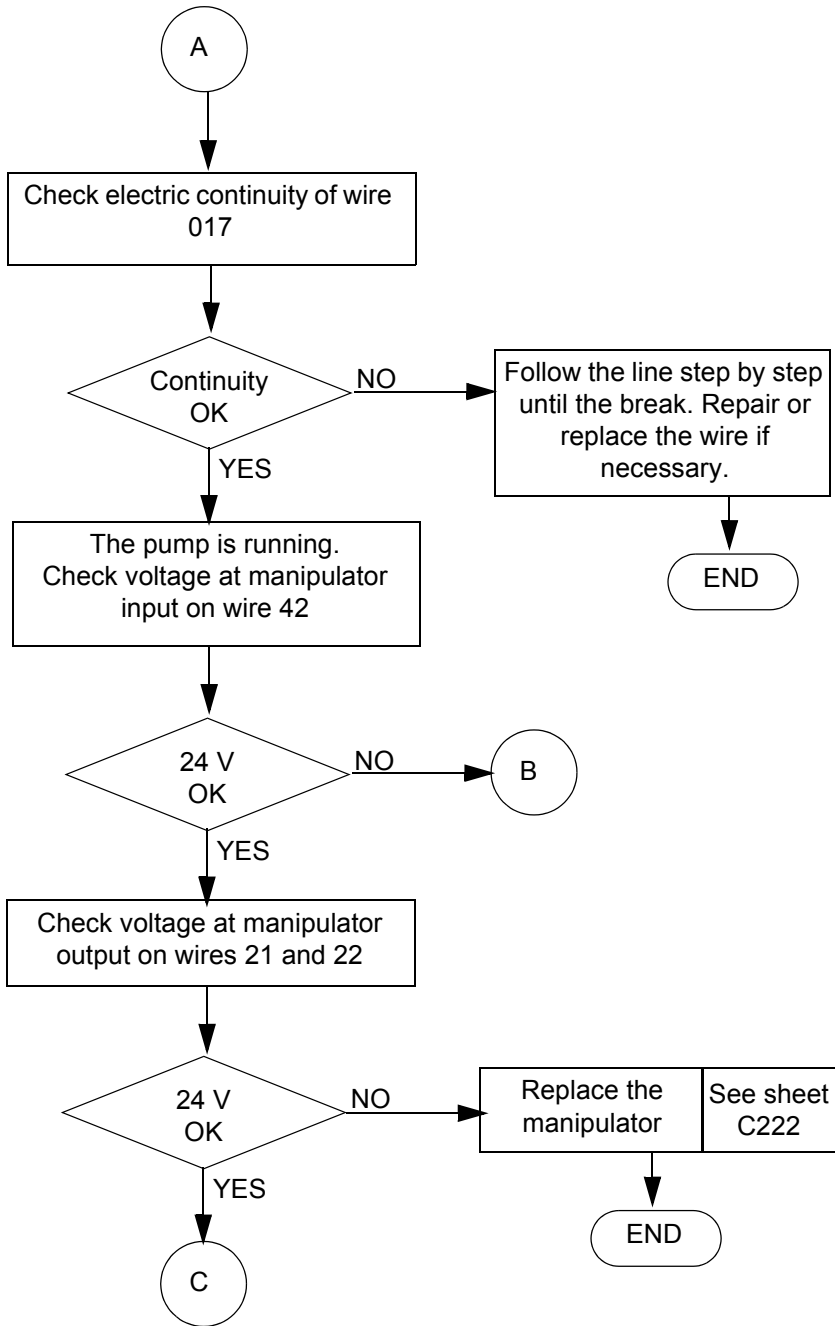

|             |   |           |
|-------------|---|-----------|
| Sheet DP143 | BREAKDOWN DETECTION FLOW CHART            | Folio 3/6 |
|             | NO TELESCOPING MOVEMENT FROM THE PLATFORM |           |

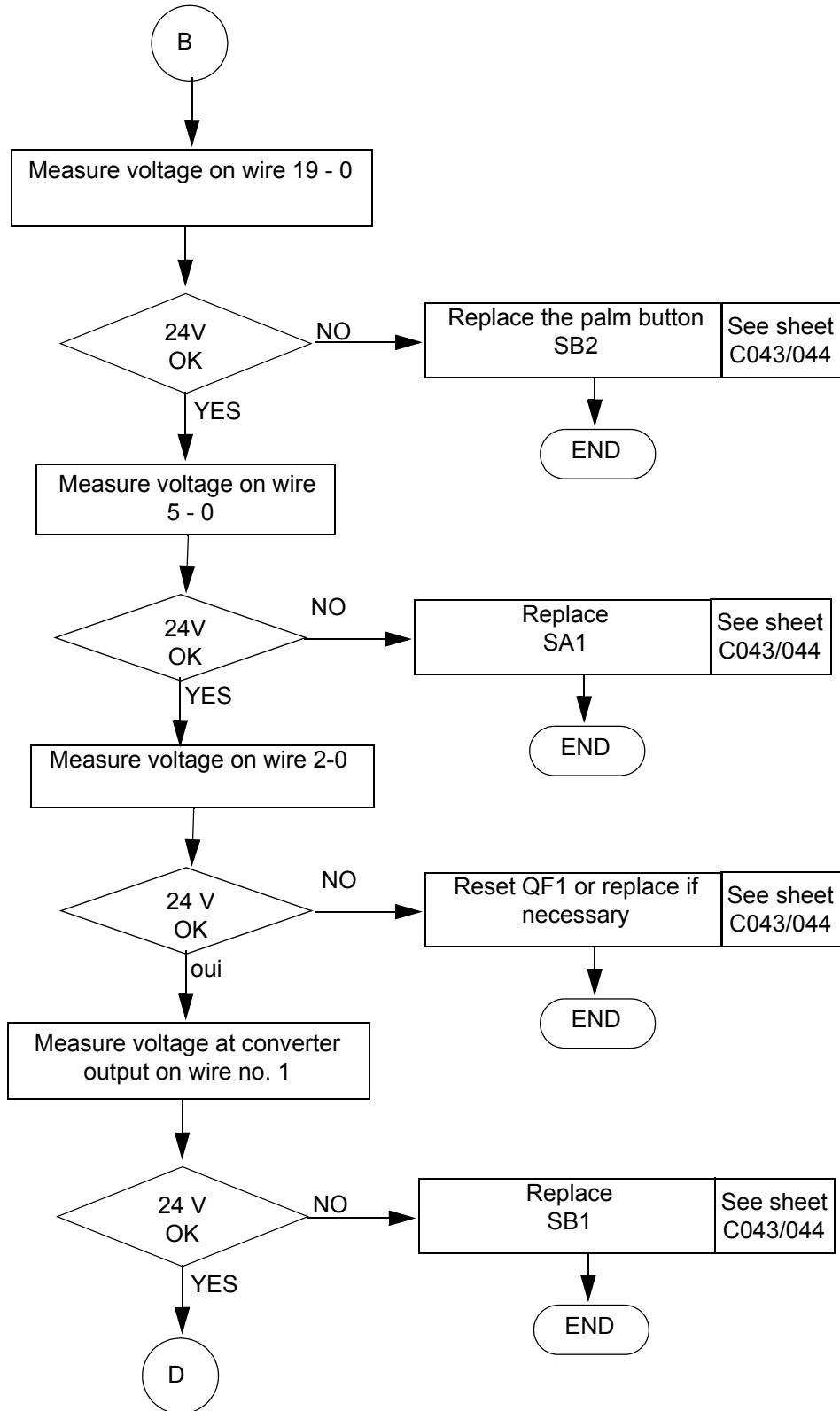

|             |   |           |
|-------------|---|-----------|
| Sheet DP143 | BREAKDOWN DETECTION FLOW CHART            | Folio 4/6 |
|             | NO TELESCOPING MOVEMENT FROM THE PLATFORM |           |

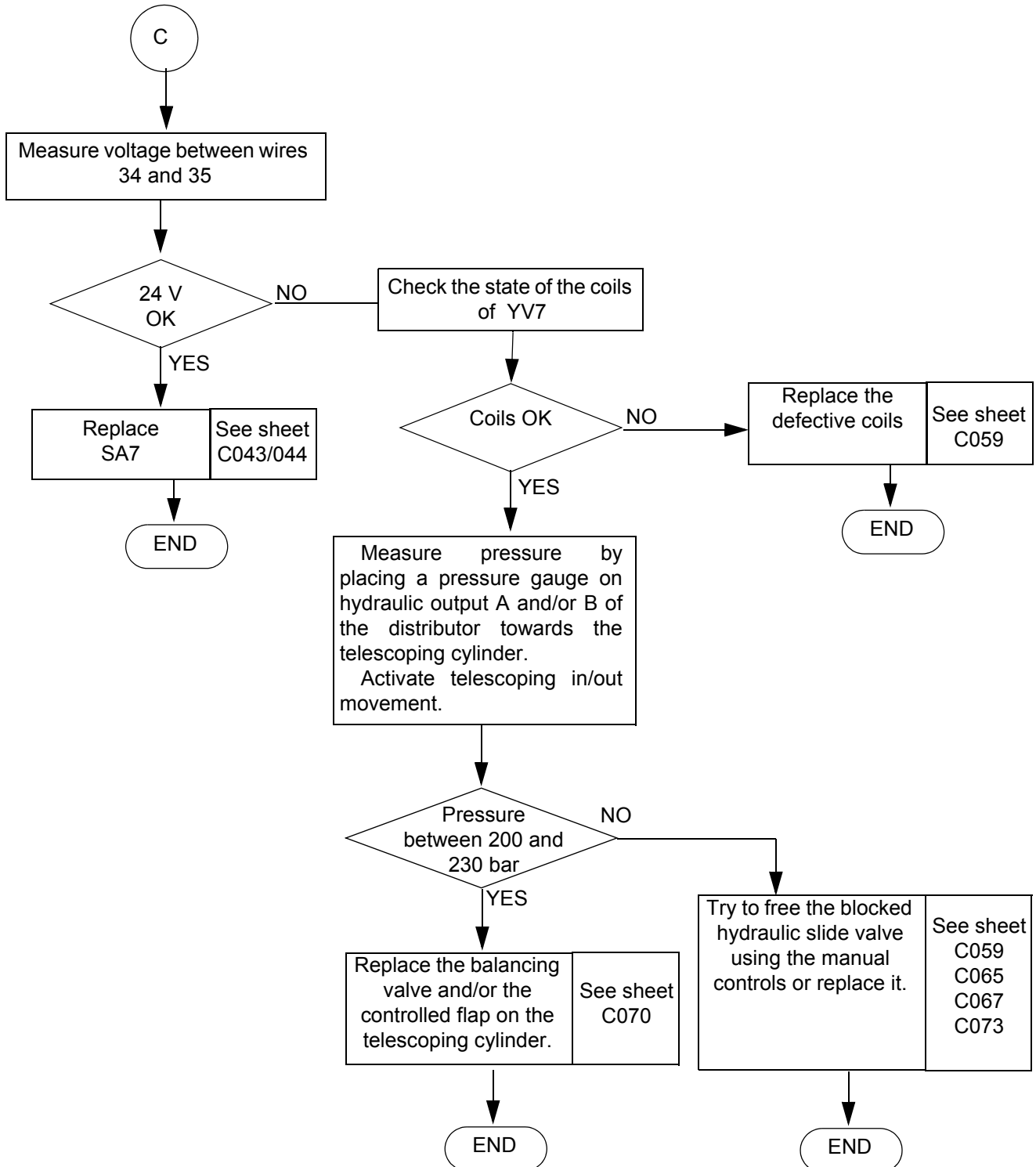

|             |   |           |
|-------------|---|-----------|
| Sheet DP143 | BREAKDOWN DETECTION FLOW CHART            | Folio 5/6 |
|             | NO TELESCOPING MOVEMENT FROM THE PLATFORM |           |

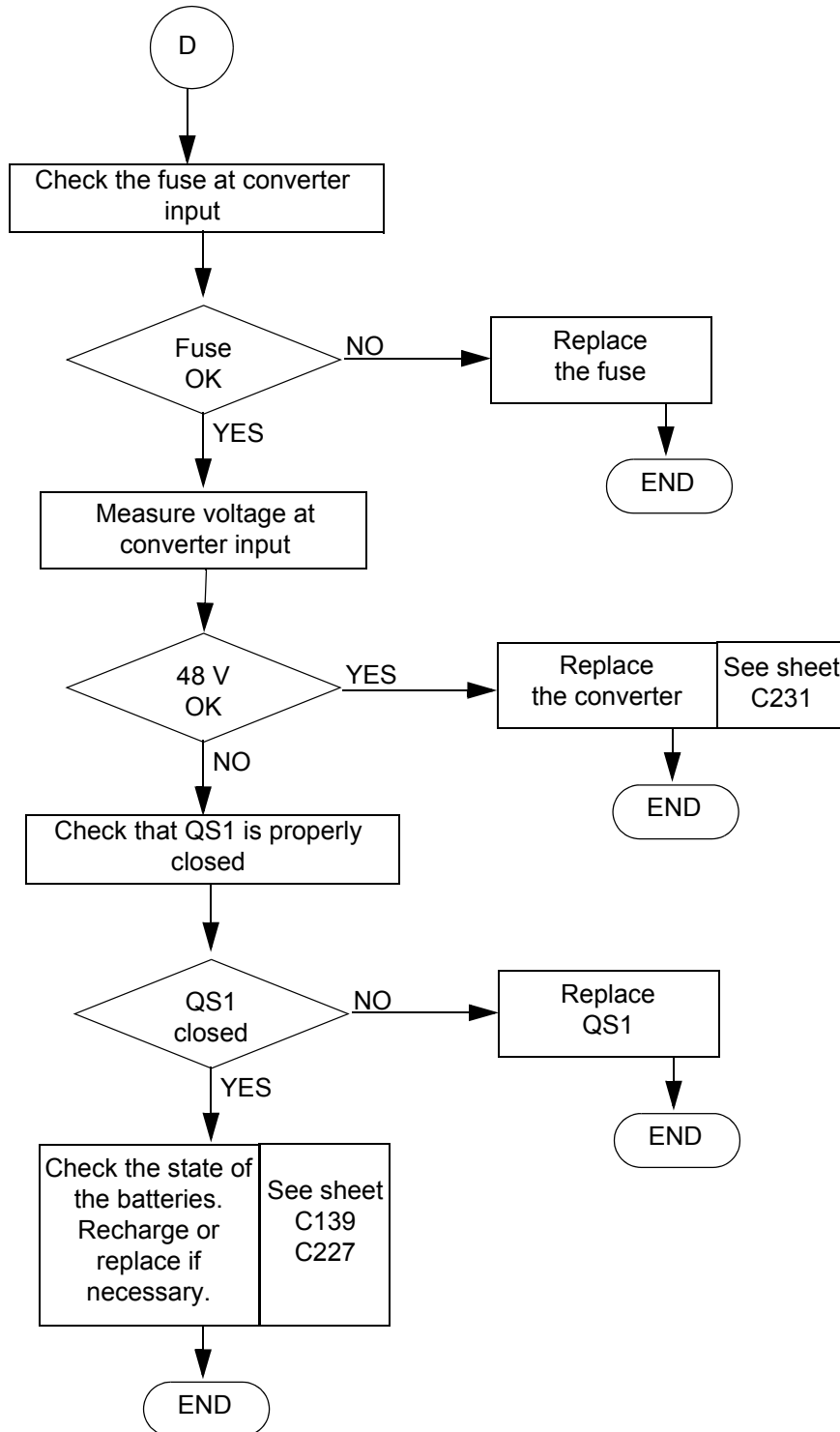

|             |  |           |
|-------------|--|-----------|
| Sheet DP143 | BREAKDOWN DETECTION FLOW CHART               | Folio 6/6 |
|             | NO TELESCOPING MOVEMENT<br>FROM THE PLATFORM |           |

|             |   |           |
|-------------|---|-----------|
| Sheet DP144 | BREAKDOWN DETECTION FLOW CHART                                  | Folio 1/2 |
|             | NO LOW SPEED FROM THE PLATFORM<br>IN EITHER DIRECTION FOR / REV |           |

No low speed available from the platform control panel. The machine remains in high speed.

Put the key selection switch in the platform position.  
Put the switch in the low speed position.  
Activate the travel manipulator while pressing the failsafe pedal.  
Ensure that the batteries are properly charged.

Measure voltage on wire 80

Voltage = 0V

NO

Replace SA2      See sheet C043

END

YES

Check the table of chopper operating incidents or replace the chopper.      See sheet C003

END

|             |   |           |
|-------------|---|-----------|
| Sheet DP144 | BREAKDOWN DETECTION FLOW CHART                                  | Folio 2/2 |
|             | NO LOW SPEED FROM THE PLATFORM<br>IN EITHER DIRECTION FOR / REV |           |

|             |   |           |
|-------------|---|-----------|
| Sheet DP145 | BREAKDOWN DETECTION FLOW CHART                                | Folio 1/6 |
|             | NO SLEWING MOVEMENT IN EITHER DIRECTION L/R FROM THE PLATFORM |           |

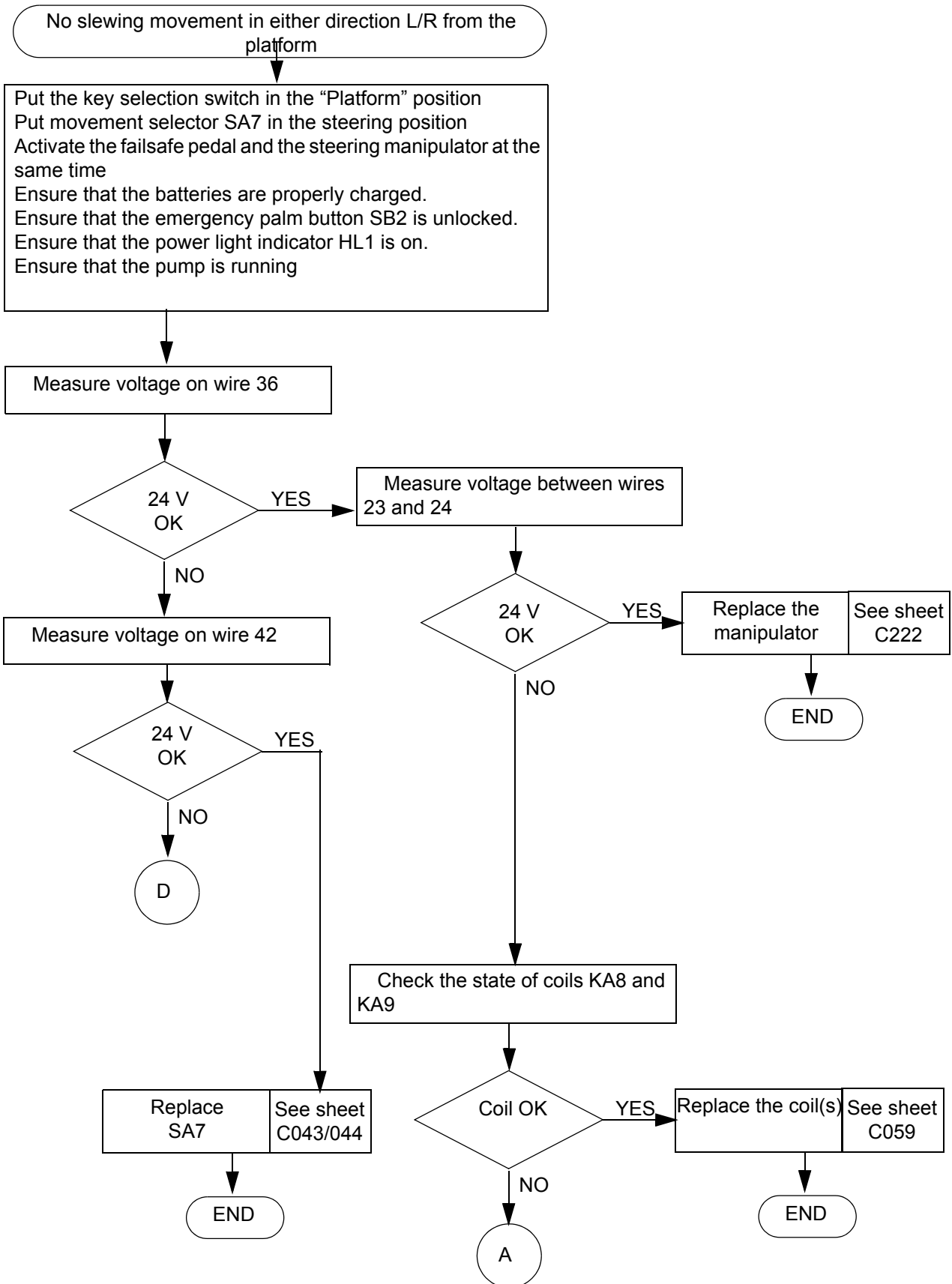

|             |  |           |
|-------------|--|-----------|
| Sheet DP145 | BREAKDOWN DETECTION FLOW CHART                                   | Folio 2/6 |
|             | NO SLEWING MOVEMENT IN EITHER DIRECTION<br>L/R FROM THE PLATFORM |           |

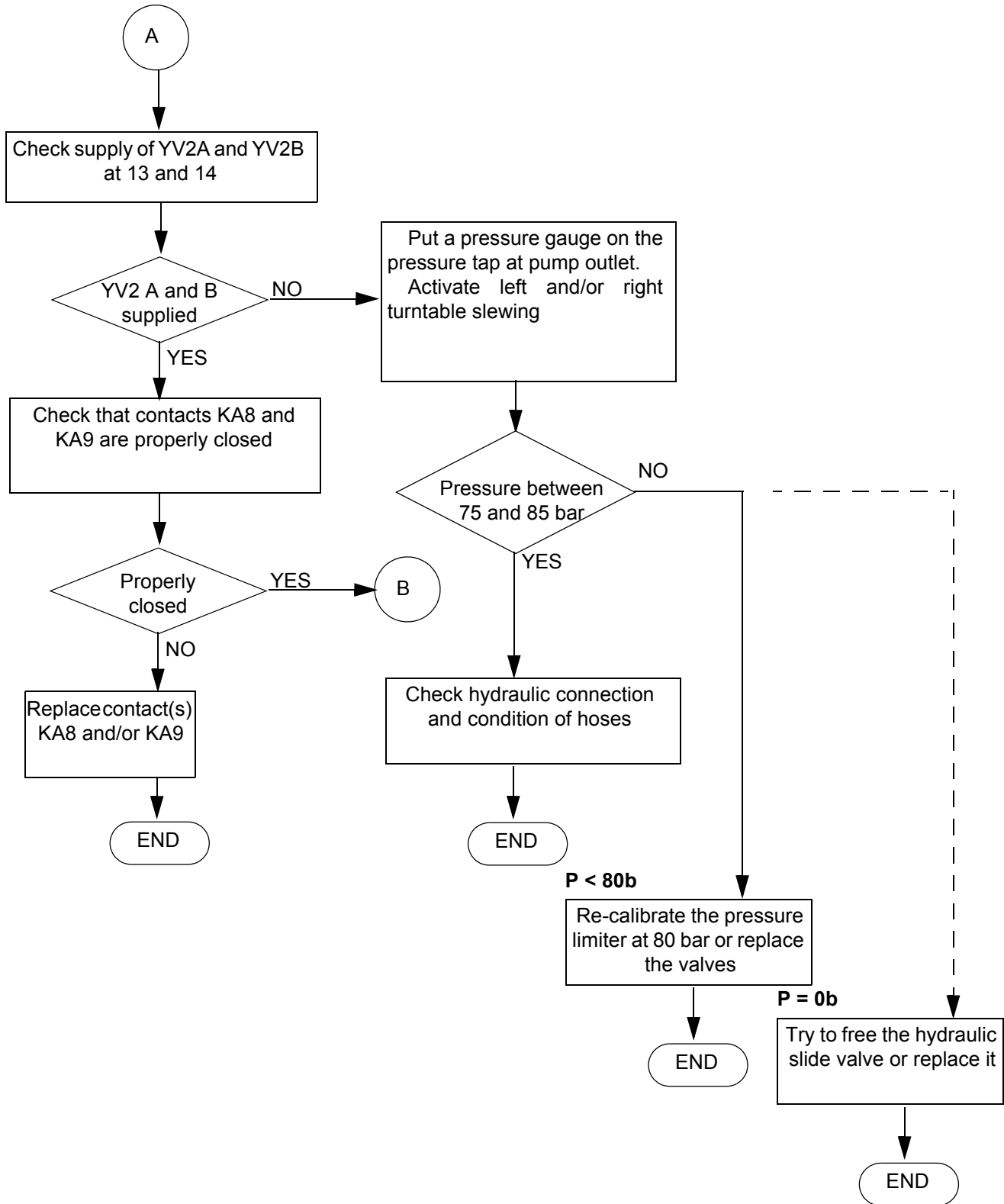

|             |  |           |
|-------------|--|-----------|
| Sheet DP145 | BREAKDOWN DETECTION FLOW CHART                                   | Folio 3/6 |
|             | NO SLEWING MOVEMENT IN EITHER DIRECTION<br>L/R FROM THE PLATFORM |           |

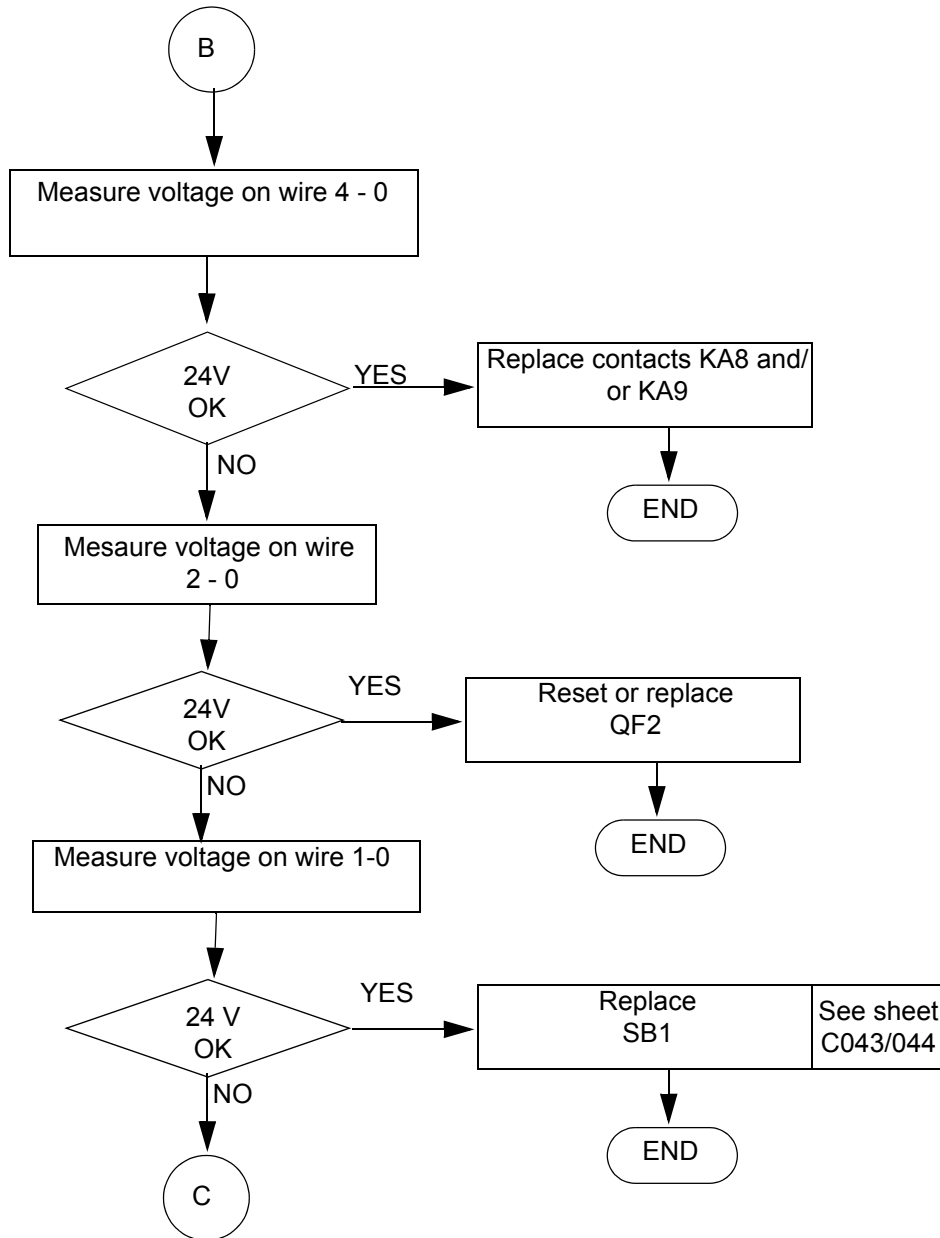

|             |  |           |
|-------------|--|-----------|
| Sheet DP145 | BREAKDOWN DETECTION FLOW CHART                                   | Folio 4/6 |
|             | NO SLEWING MOVEMENT IN EITHER DIRECTION<br>L/R FROM THE PLATFORM |           |

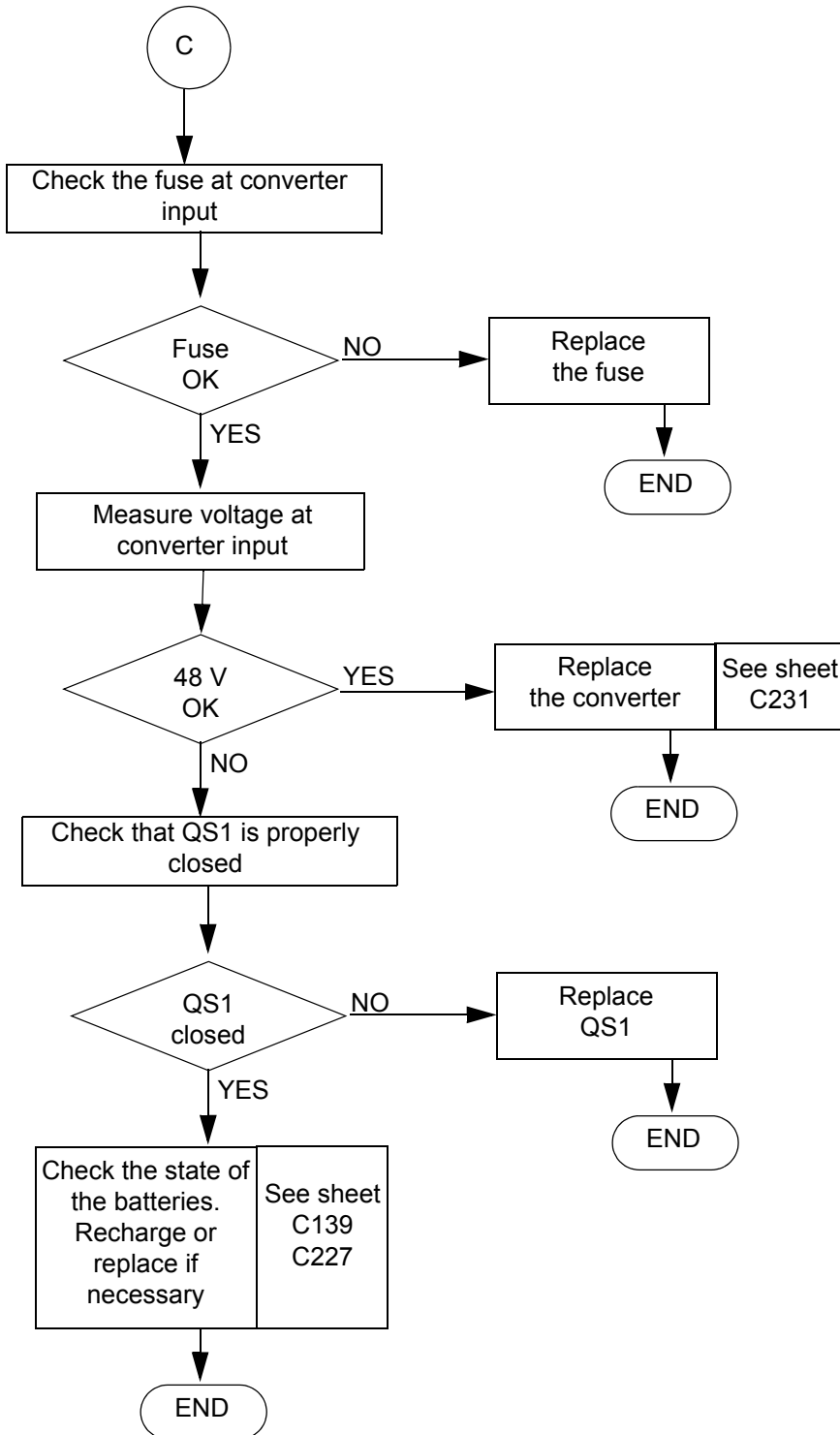

|             |  |           |
|-------------|--|-----------|
| Sheet DP145 | BREAKDOWN DETECTION FLOW CHART                                   | Folio 5/6 |
|             | NO SLEWING MOVEMENT IN EITHER DIRECTION<br>L/R FROM THE PLATFORM |           |

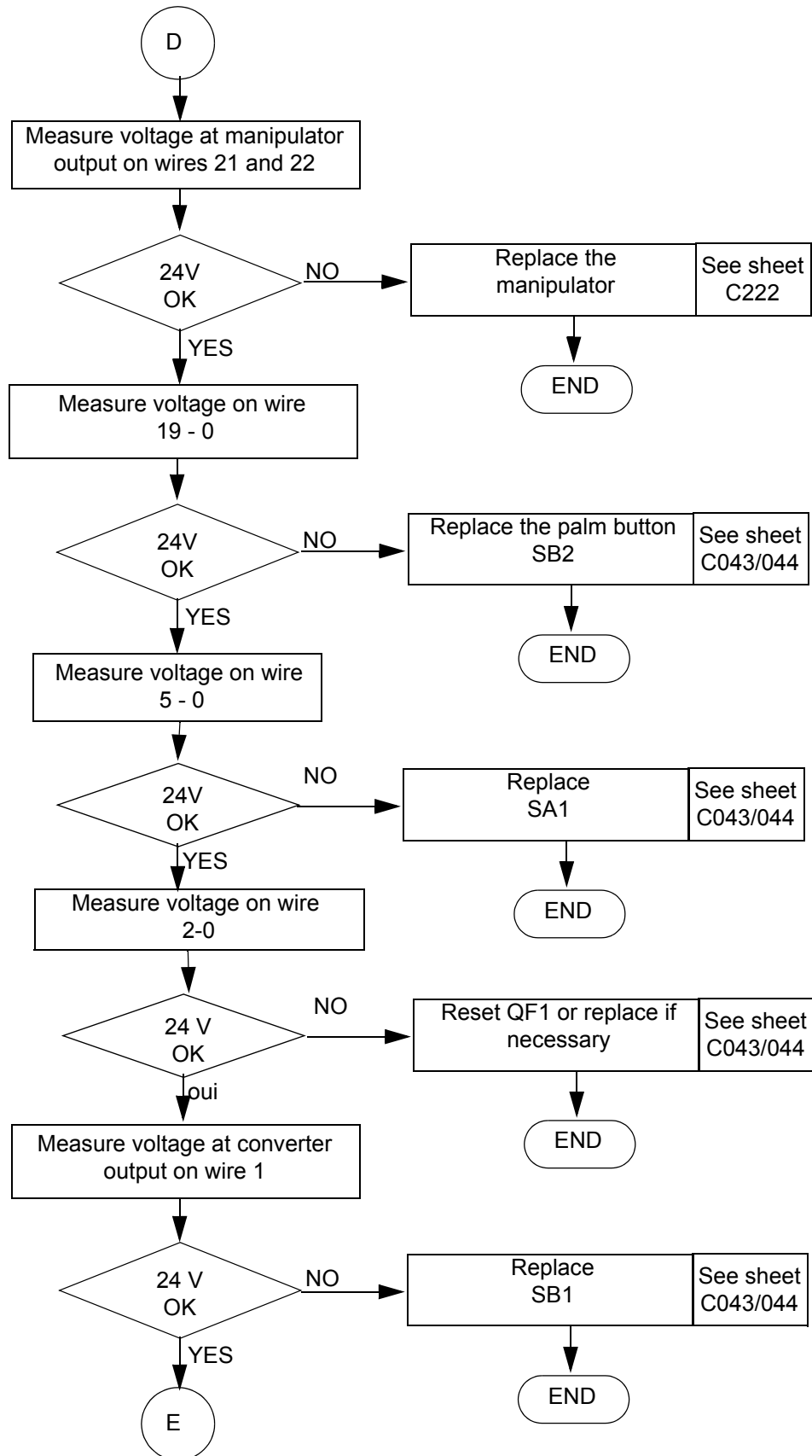

|             |  |           |
|-------------|--|-----------|
| Sheet DP145 | BREAKDOWN DETECTION FLOW CHART                                   | Folio 6/6 |
|             | NO SLEWING MOVEMENT IN EITHER DIRECTION<br>L/R FROM THE PLATFORM |           |

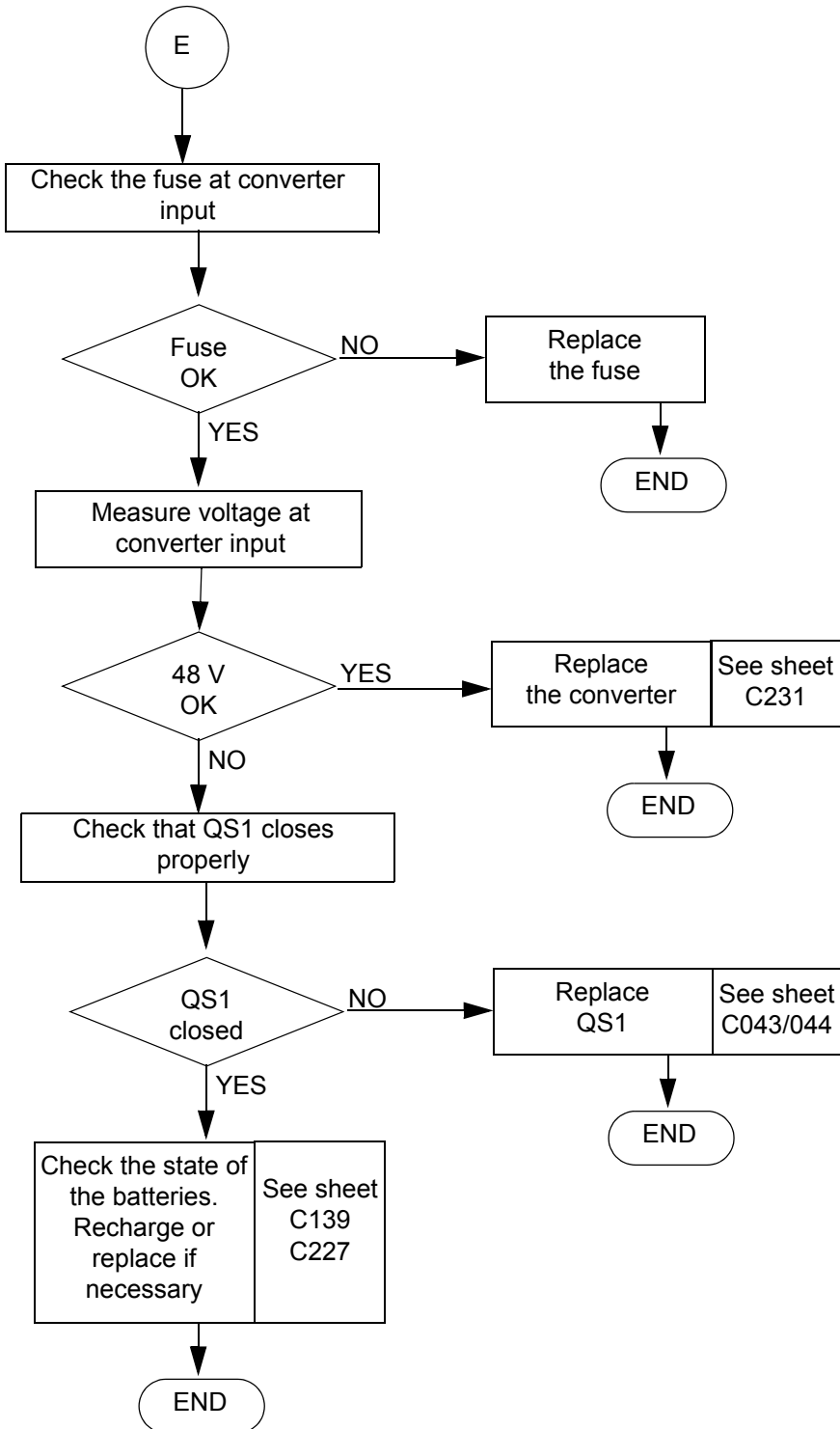

|             |   |           |
|-------------|---|-----------|
| Sheet DP146 | BREAKDOWN DETECTION FLOW CHART                  | Folio 1/6 |
|             | THE ELECTROPUMP DOES NOT WORK FROM THE PLATFORM |           |

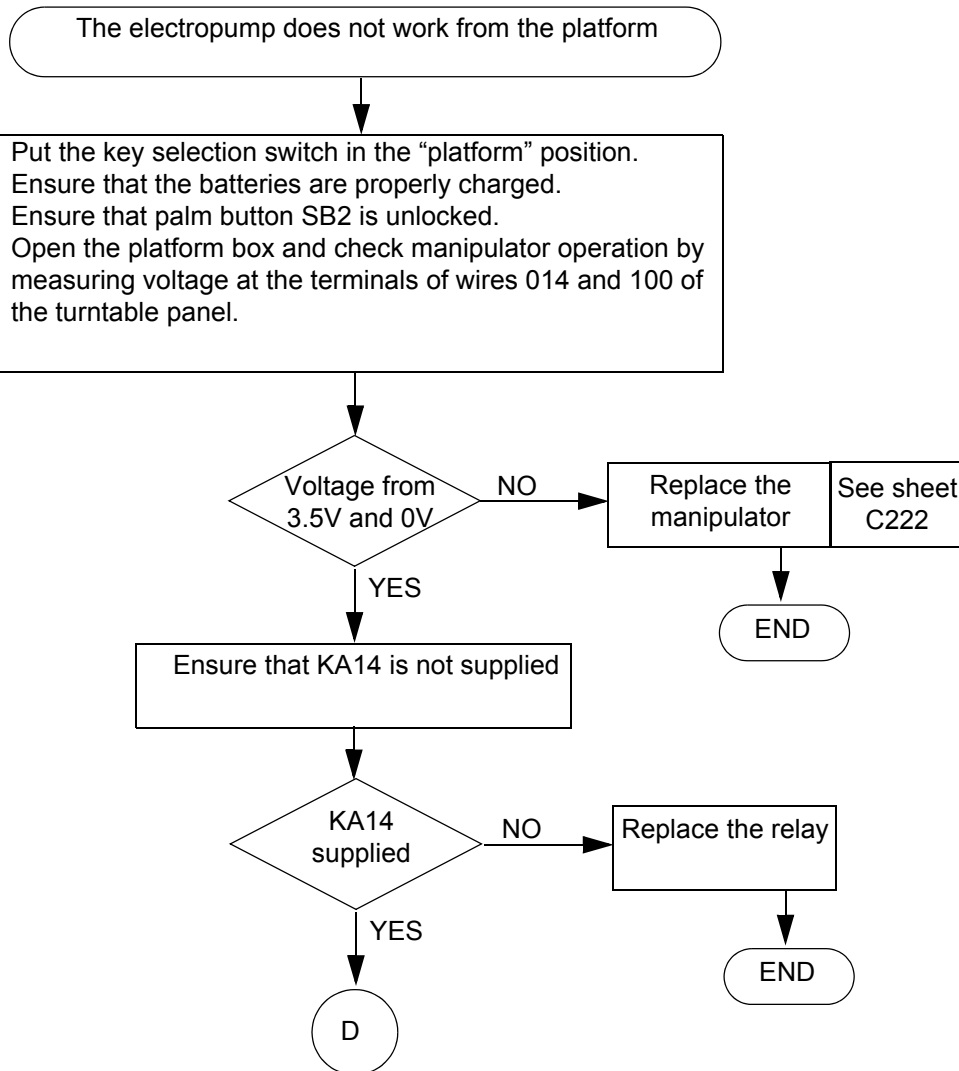

|             |   |           |
|-------------|---|-----------|
| Sheet DP146 | BREAKDOWN DETECTION FLOW CHART                  | Folio 2/6 |
|             | THE ELECTROPUMP DOES NOT WORK FROM THE PLATFORM |           |

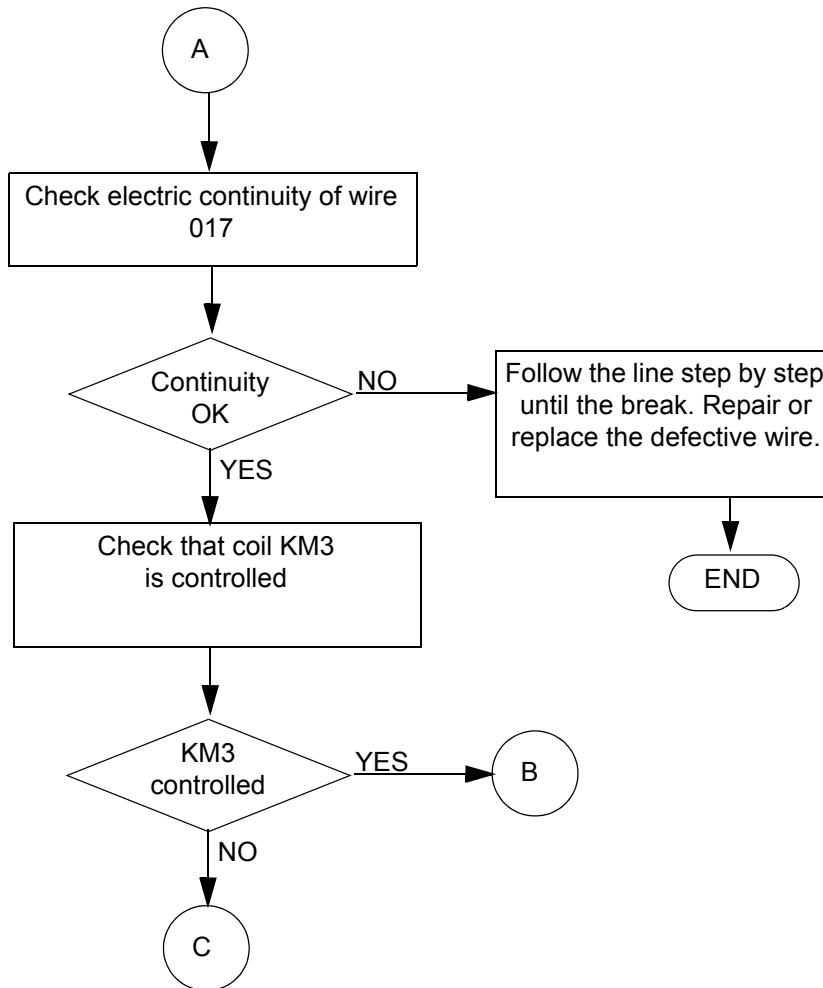

|             |   |           |
|-------------|---|-----------|
| Sheet DP146 | BREAKDOWN DETECTION FLOW CHART                  | Folio 3/6 |
|             | THE ELECTROPUMP DOES NOT WORK FROM THE PLATFORM |           |

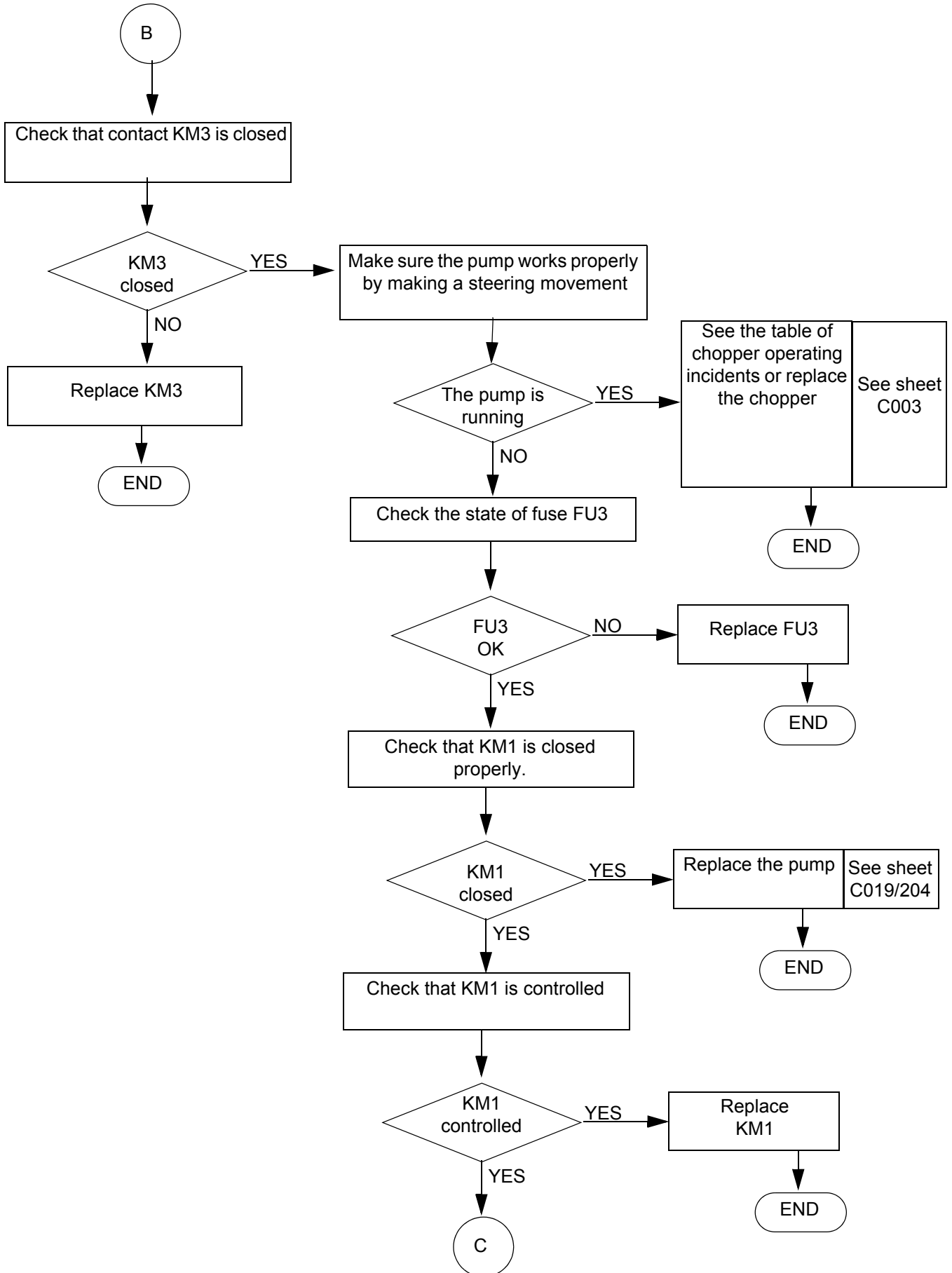

|             |   |           |
|-------------|---|-----------|
| Sheet DP146 | BREAKDOWN DETECTION FLOW CHART                  | Folio 4/6 |
|             | THE ELECTROPUMP DOES NOT WORK FROM THE PLATFORM |           |

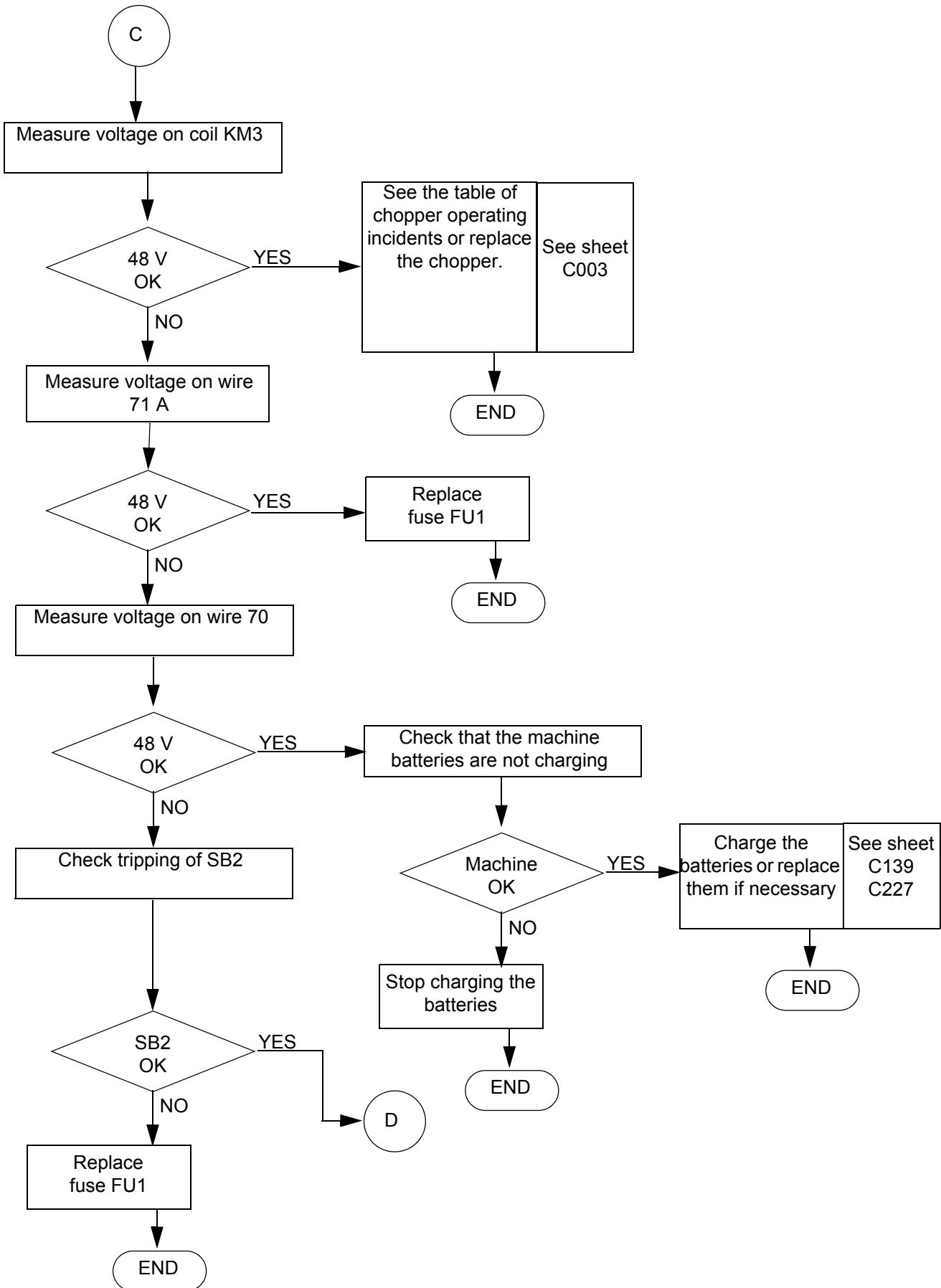

|             |   |           |
|-------------|---|-----------|
| Sheet DP146 | BREAKDOWN DETECTION FLOW CHART                  | Folio 5/6 |
|             | THE ELECTROPUMP DOES NOT WORK FROM THE PLATFORM |           |

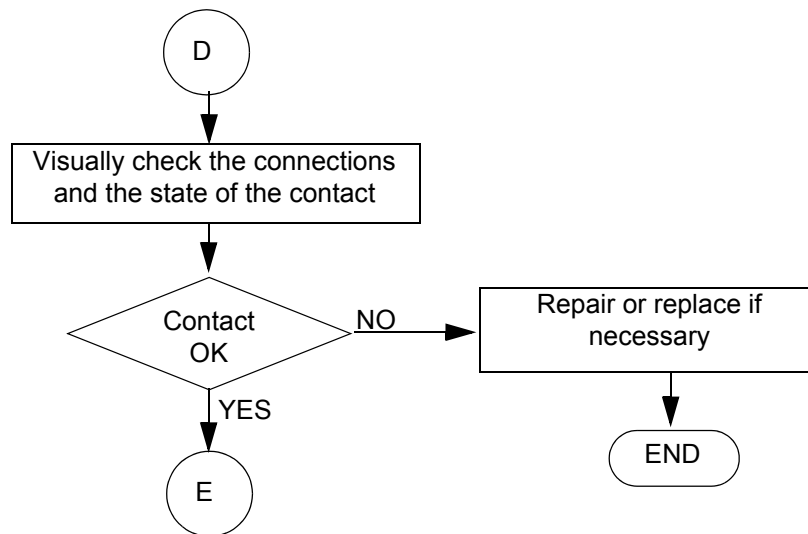

|             |   |           |
|-------------|---|-----------|
| Sheet DP146 | BREAKDOWN DETECTION FLOW CHART                  | Folio 6/6 |
|             | THE ELECTROPUMP DOES NOT WORK FROM THE PLATFORM |           |

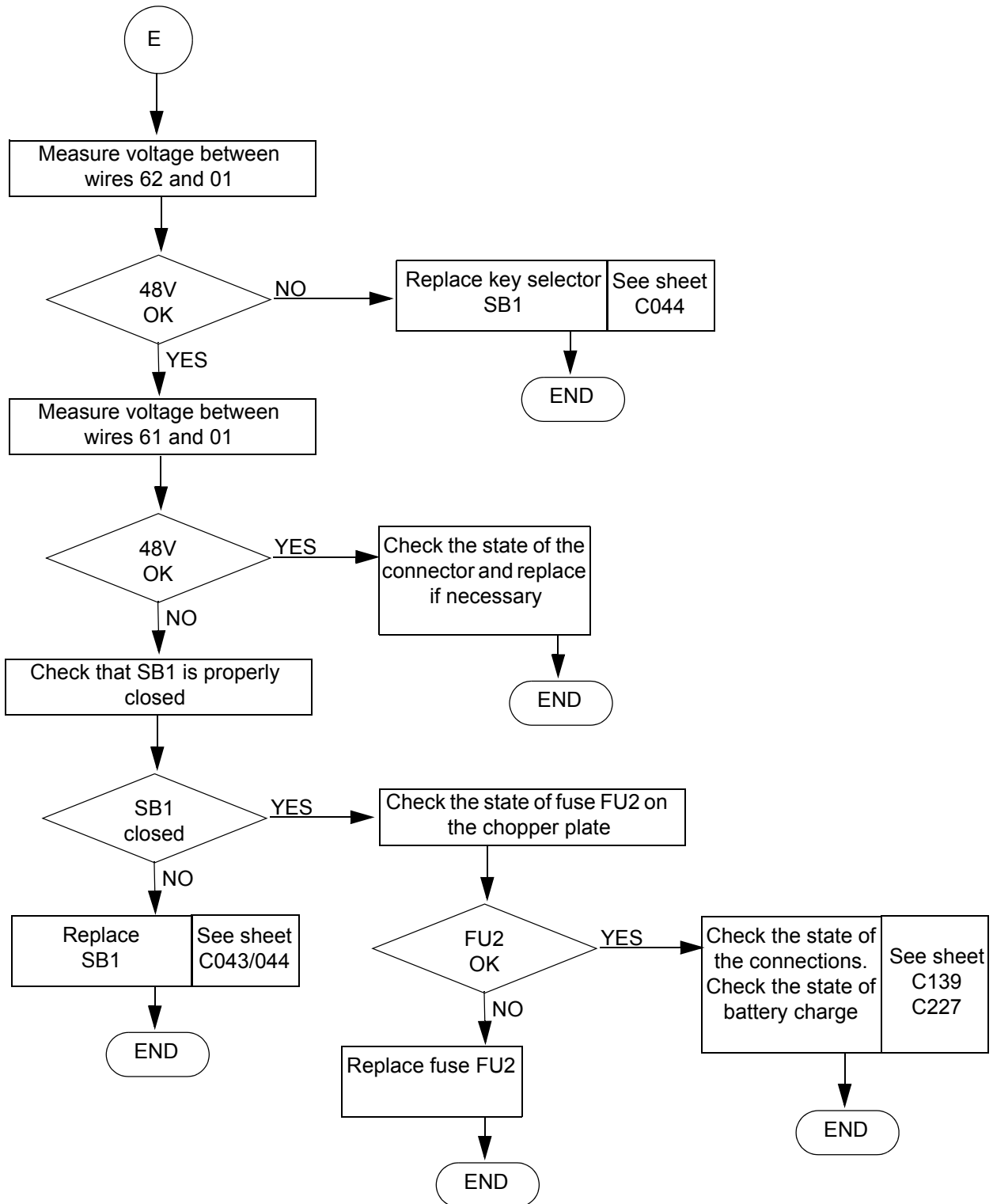

|             |  |           |
|-------------|--|-----------|
| Sheet DP147 | BREAKDOWN DETECTION FLOW CHART                           | Folio 1/4 |
|             | NO TELESCOPING MOVEMENT FROM THE TURNTABLE CONTROL PANEL |           |

No telescoping movement from the turntable control panel

Put the key selection switch in the "turntable" position.  
 Ensure that the batteries are properly charged.  
 Ensure that the palm button SB1 is unlocked.  
 Ensure that the machine is not tilted.  
 Activate the telescoping switch SA6.  
 Ensure that the electropump works properly by activating SB4.

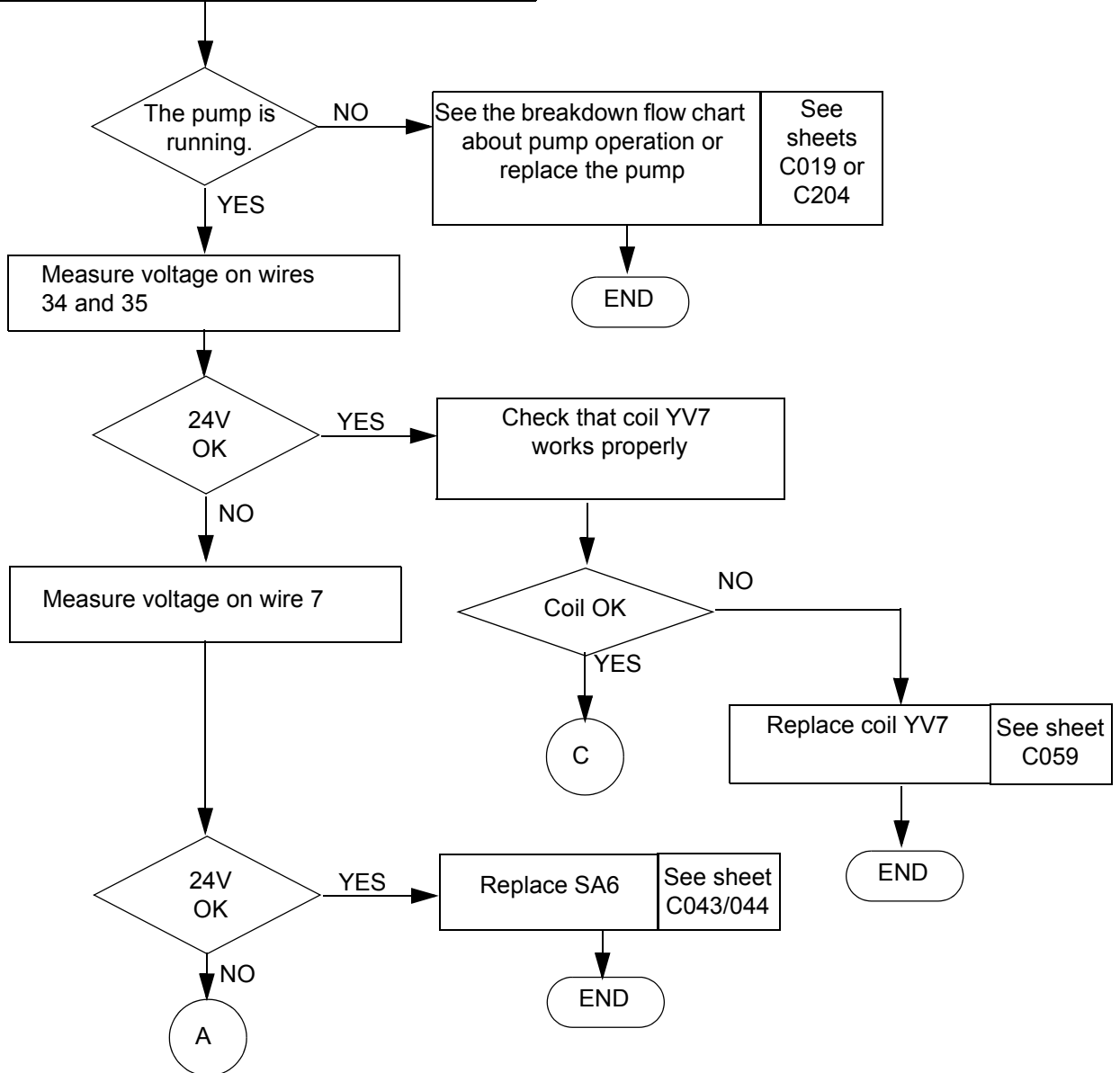

|             |   |           |
|-------------|---|-----------|
| Sheet DP147 | BREAKDOWN DETECTION FLOW CHART                              | Folio 2/4 |
|             | NO TELESCOPING MOVEMENT<br>FROM THE TURNTABLE CONTROL PANEL |           |

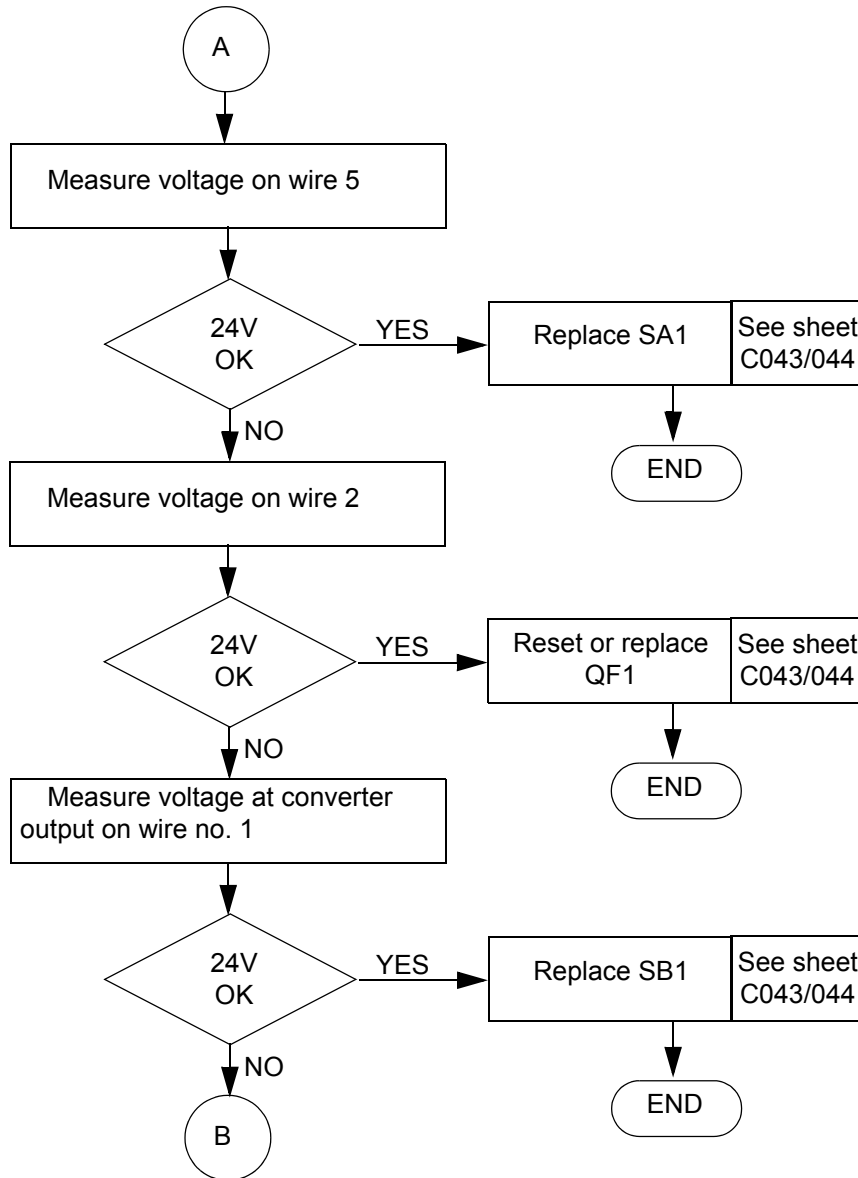

|             |  |           |
|-------------|--|-----------|
| Sheet DP147 | BREAKDOWN DETECTION FLOW CHART                           | Folio 3/4 |
|             | NO TELESCOPING MOVEMENT FROM THE TURNTABLE CONTROL PANEL |           |

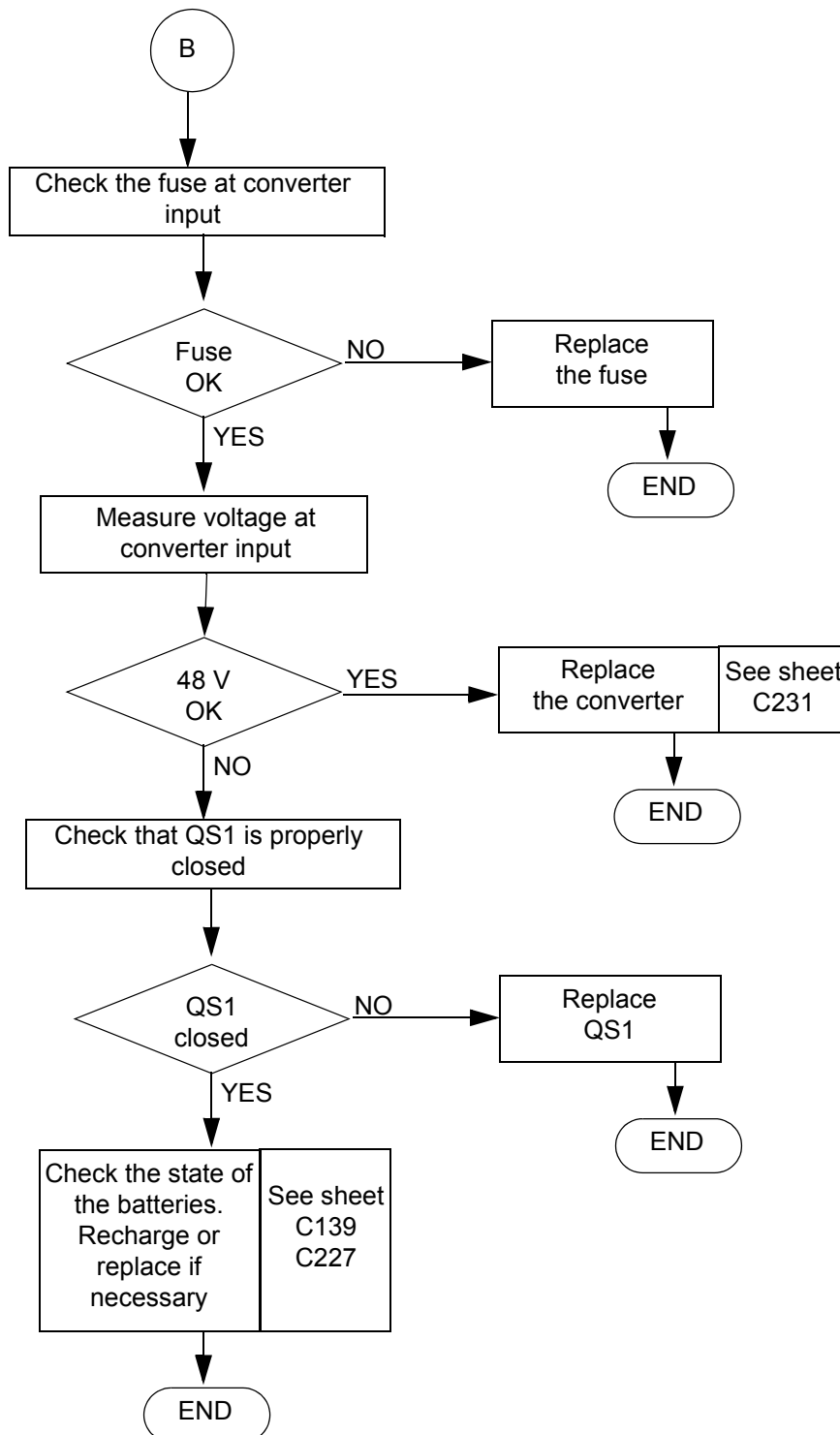

|             |   |           |
|-------------|---|-----------|
| Sheet DP147 | BREAKDOWN DETECTION FLOW CHART                              | Folio 4/4 |
|             | NO TELESCOPING MOVEMENT<br>FROM THE TURNTABLE CONTROL PANEL |           |

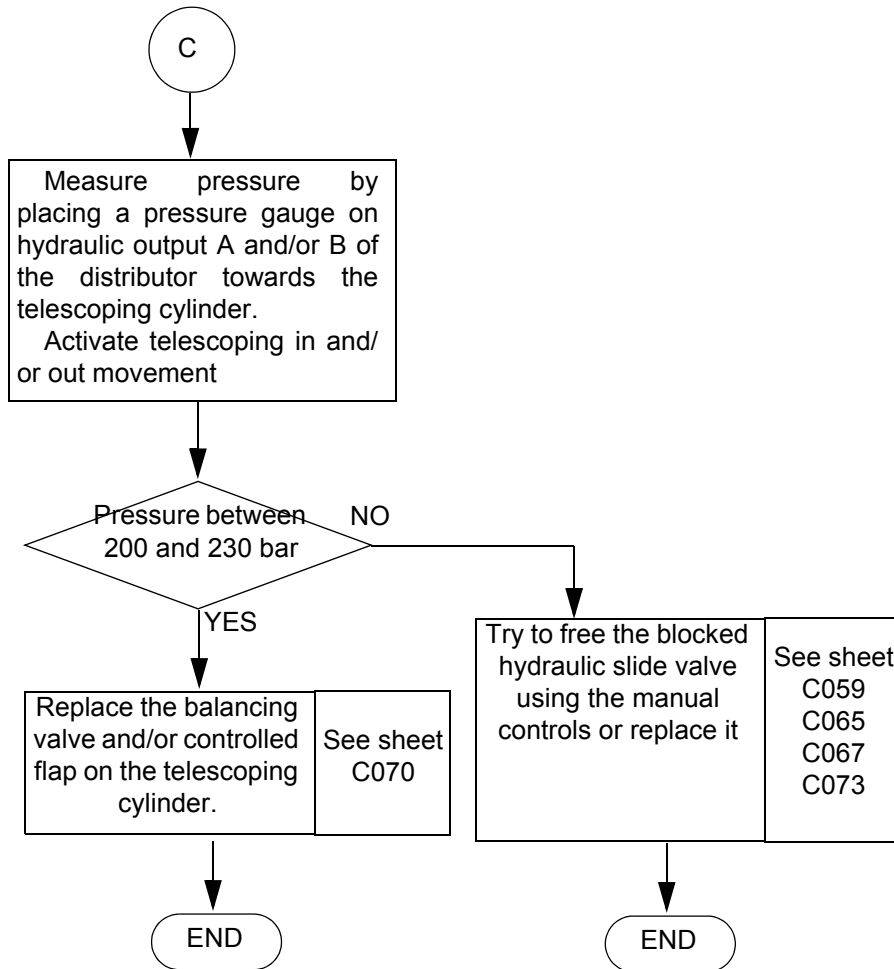

|             |   |           |
|-------------|---|-----------|
| Sheet DP148 | BREAKDOWN DETECTION FLOW CHART                            | Folio 1/4 |
|             | NO BOOM LIFTING MOVEMENT FROM THE TURNTABLE CONTROL PANEL |           |

No boom lifting movement from the turntable control panel

Put the key selection switch in the "turntable" position  
 Ensure that the batteries are properly charged.  
 Ensure that the palm button SB1 is unlocked.  
 Ensure that the machine is not tilted.  
 Activate the boom lifting switch SA5.  
 Ensure that the electropump is running by activating SB4.

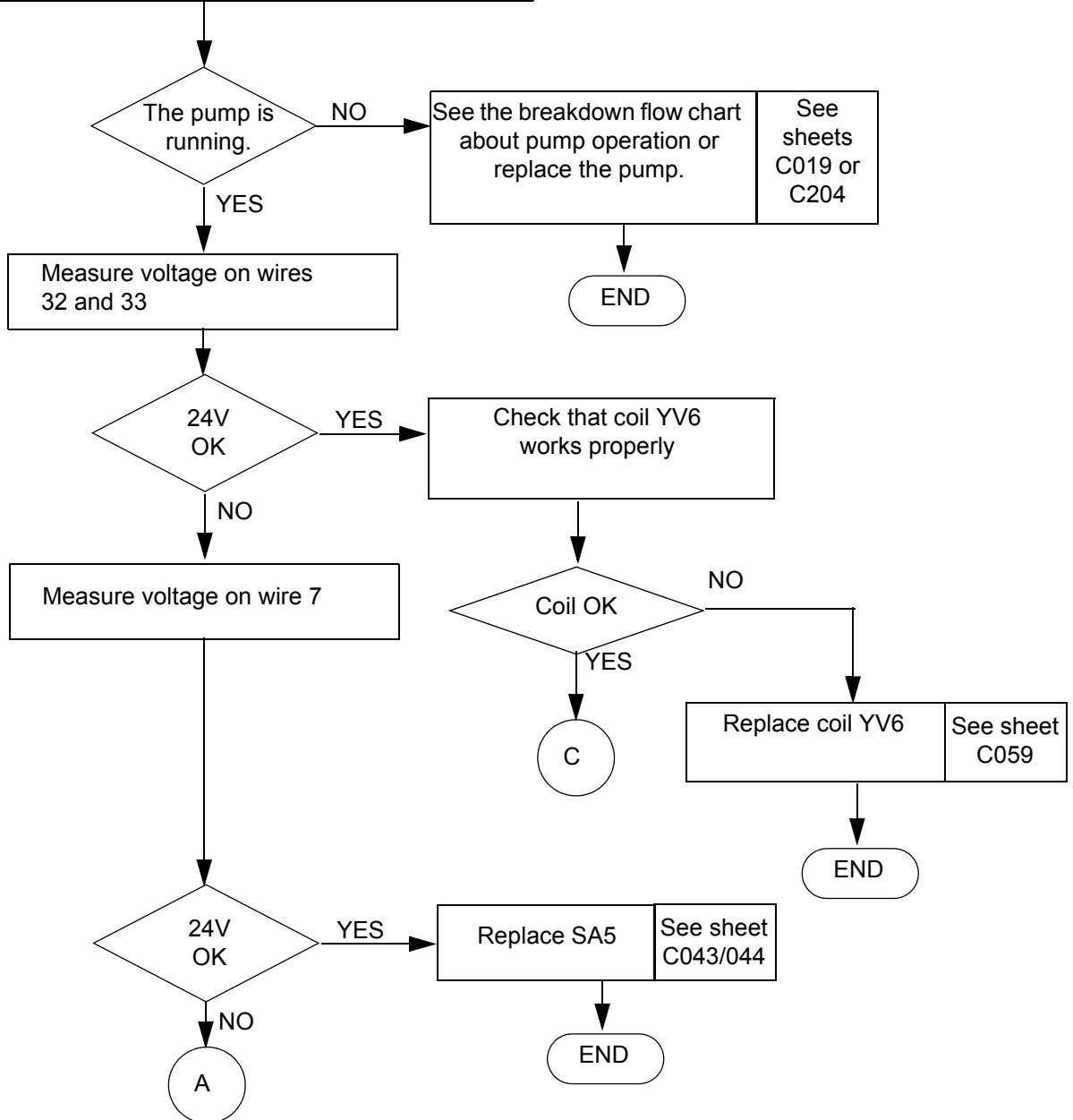

|             |   |           |
|-------------|---|-----------|
| Sheet DP148 | BREAKDOWN DETECTION FLOW CHART                            | Folio 2/4 |
|             | NO BOOM LIFTING MOVEMENT FROM THE TURNTABLE CONTROL PANEL |           |

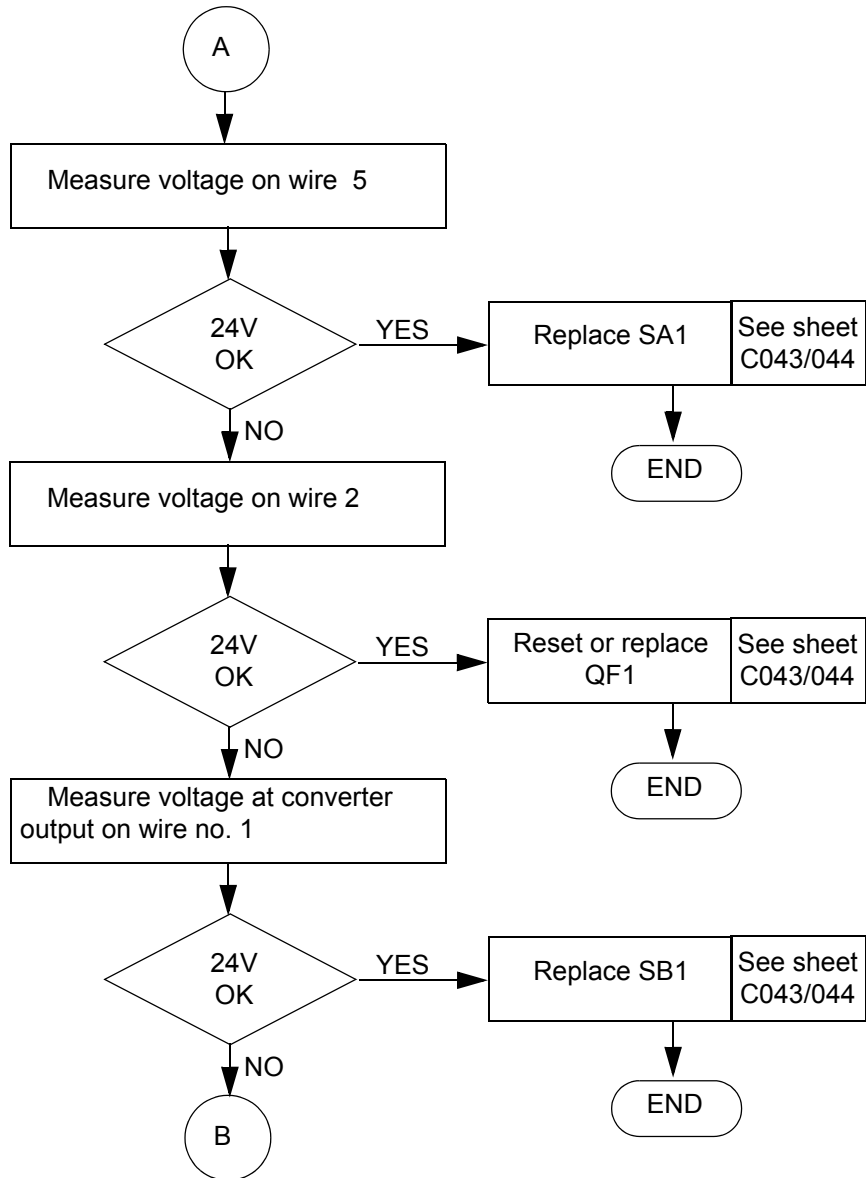

|             |   |           |
|-------------|---|-----------|
| Sheet DP148 | BREAKDOWN DETECTION FLOW CHART                            | Folio 3/4 |
|             | NO BOOM LIFTING MOVEMENT FROM THE TURNTABLE CONTROL PANEL |           |

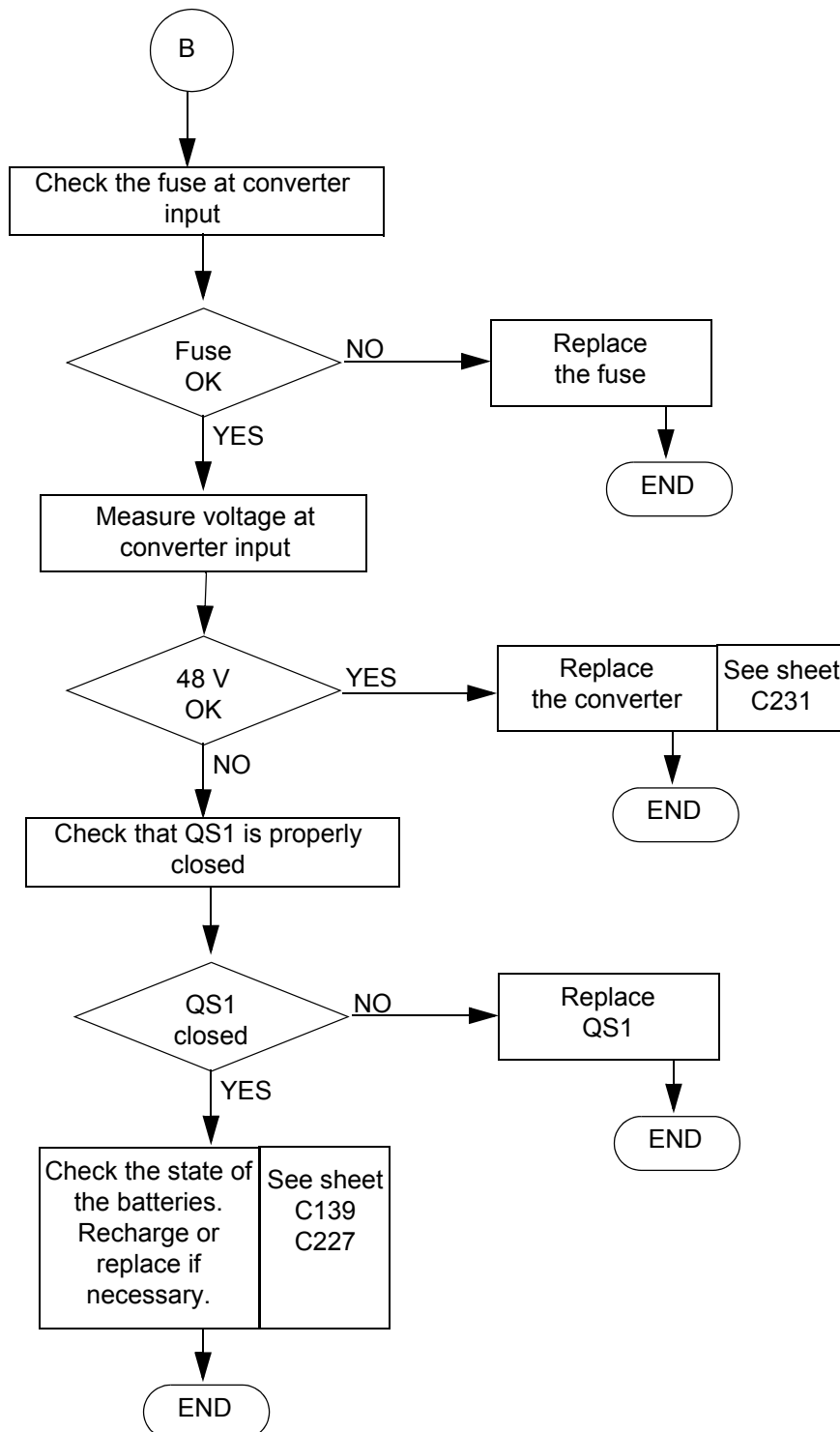

|             |  |           |
|-------------|--|-----------|
| Sheet DP148 | BREAKDOWN DETECTION FLOW CHART                               | Folio 4/4 |
|             | NO BOOM LIFTING MOVEMENT<br>FROM THE TURNTABLE CONTROL PANEL |           |

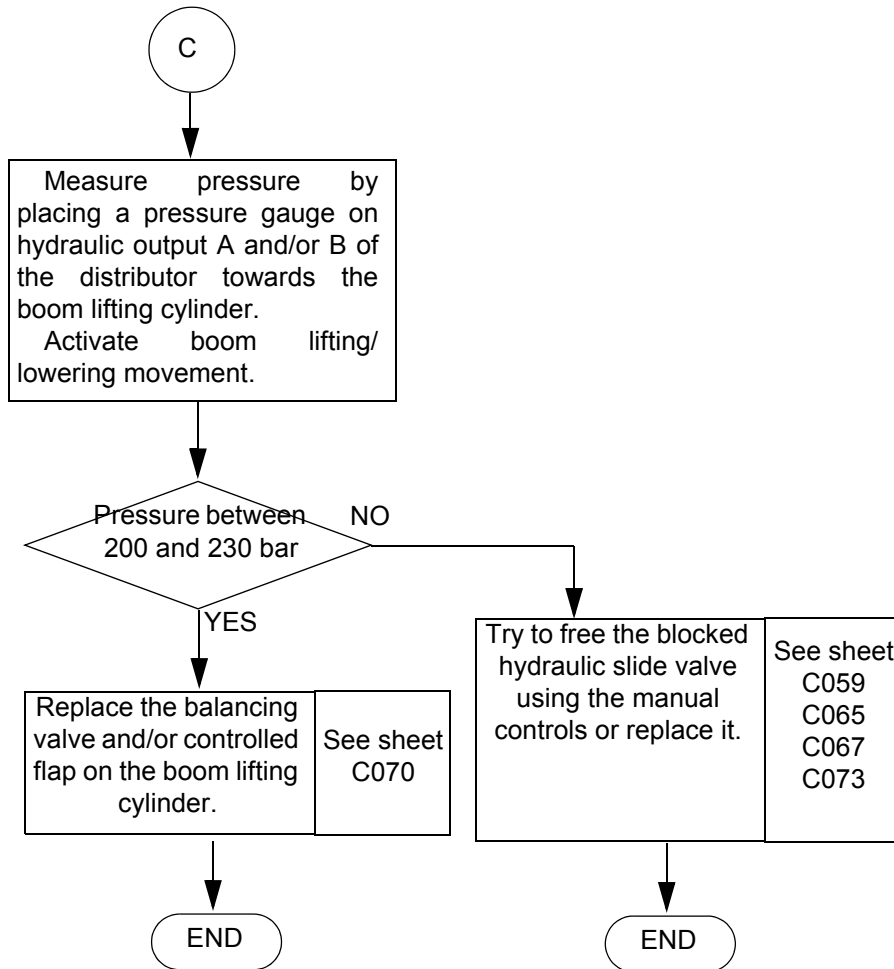

|             |  |           |
|-------------|--|-----------|
| Sheet DP149 | BREAKDOWN DETECTION FLOW CHART                           | Folio 1/4 |
|             | NO ARM LIFTING MOVEMENT FROM THE TURNTABLE CONTROL PANEL |           |

No arm lifting movement from the turntable control panel

Put the key selection switch in the "turntable" position.  
 Ensure that the batteries are properly charged.  
 Ensure that the palm button SB1 is unlocked.  
 Ensure that the machine is not tilted.  
 Activate the arm lifting switch SA4.  
 Ensure that the electropump is running by activating SB4.

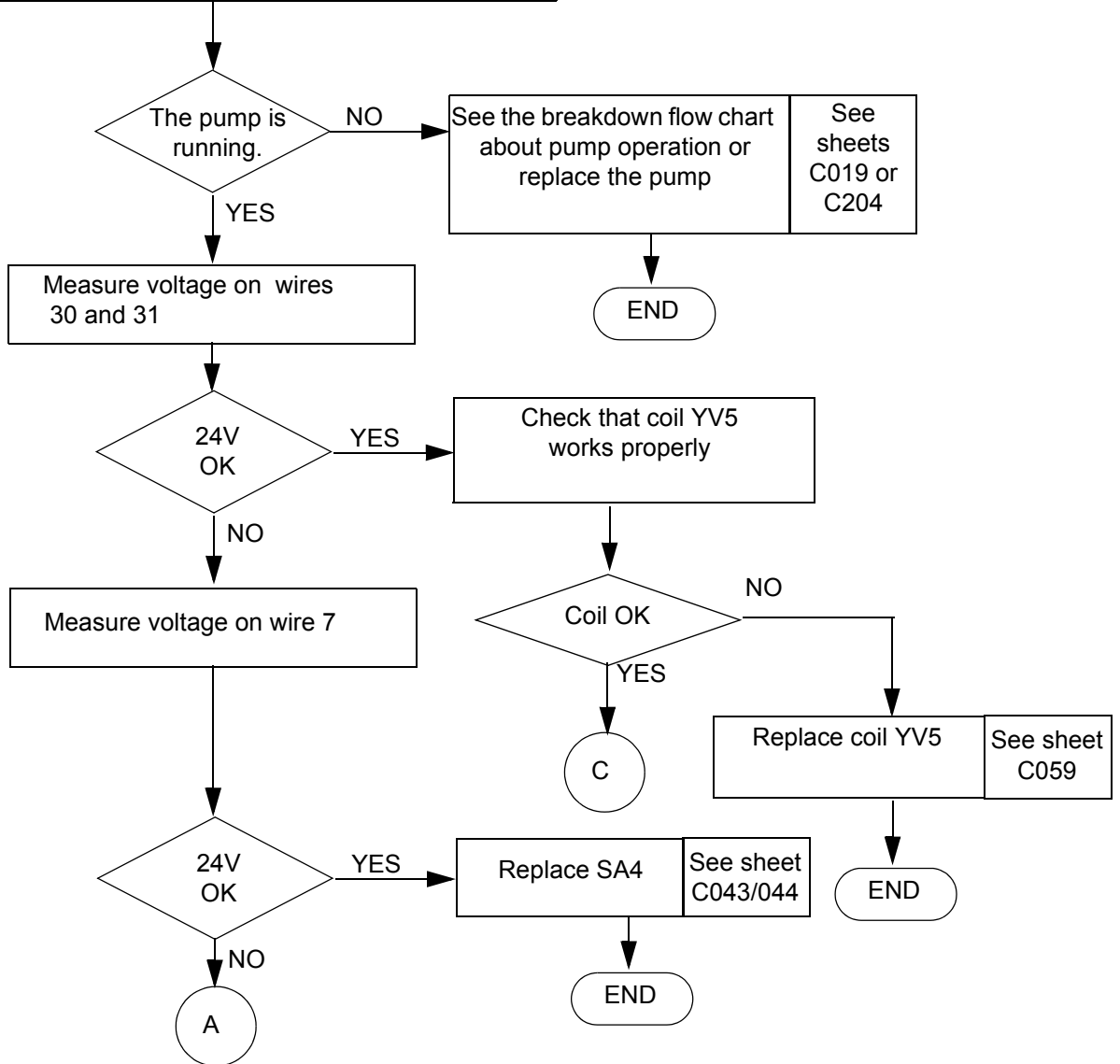

|             |  |           |
|-------------|--|-----------|
| Sheet DP149 | BREAKDOWN DETECTION FLOW CHART                           | Folio 2/4 |
|             | NO ARM LIFTING MOVEMENT FROM THE TURNTABLE CONTROL PANEL |           |

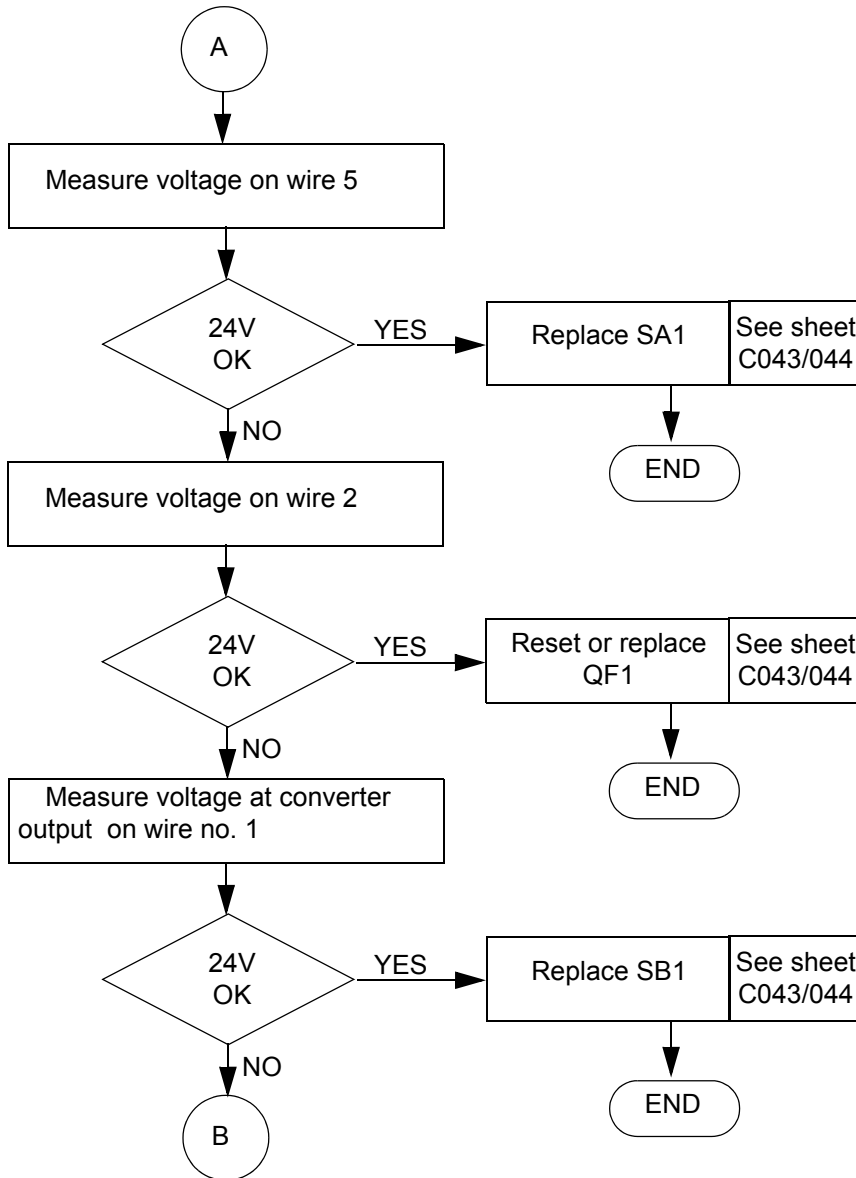

|             |  |           |
|-------------|--|-----------|
| Sheet DP149 | BREAKDOWN DETECTION FLOW CHART                           | Folio 3/4 |
|             | NO ARM LIFTING MOVEMENT FROM THE TURNTABLE CONTROL PANEL |           |

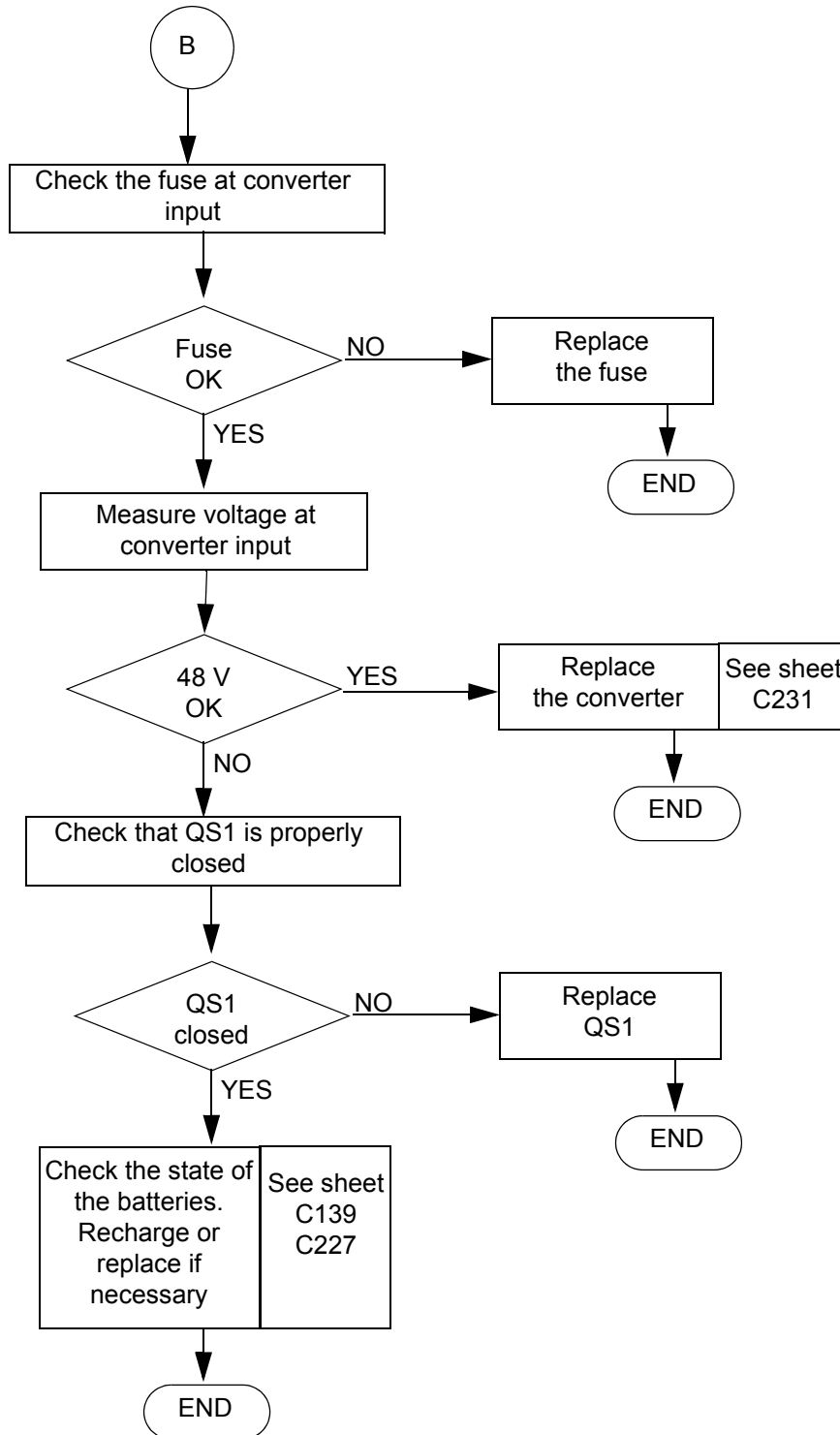

|             |   |           |
|-------------|---|-----------|
| Sheet DP149 | BREAKDOWN DETECTION FLOW CHART                              | Folio 4/4 |
|             | NO ARM LIFTING MOVEMENT<br>FROM THE TURNTABLE CONTROL PANEL |           |

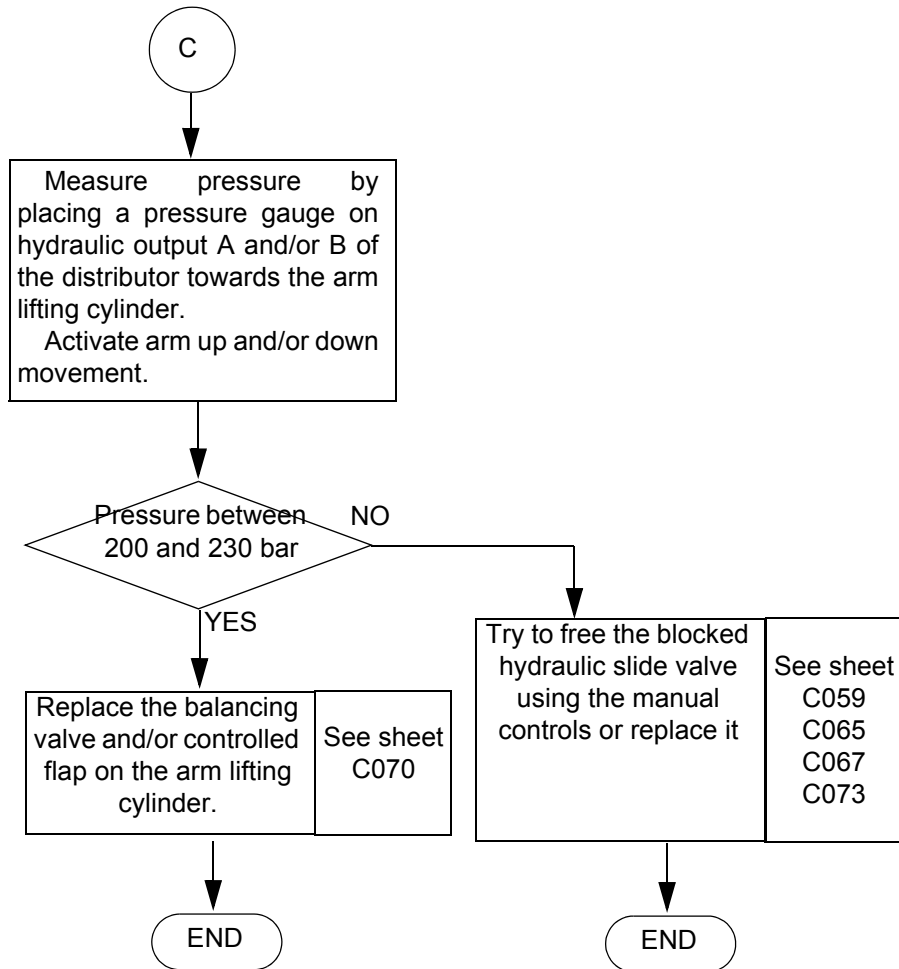

|             |  |           |
|-------------|--|-----------|
| Sheet DP150 | BREAKDOWN DETECTION FLOW CHART                           | Folio 1/4 |
|             | NO L/R SLEWING MOVEMENT FROM THE TURNTABLE CONTROL PANEL |           |

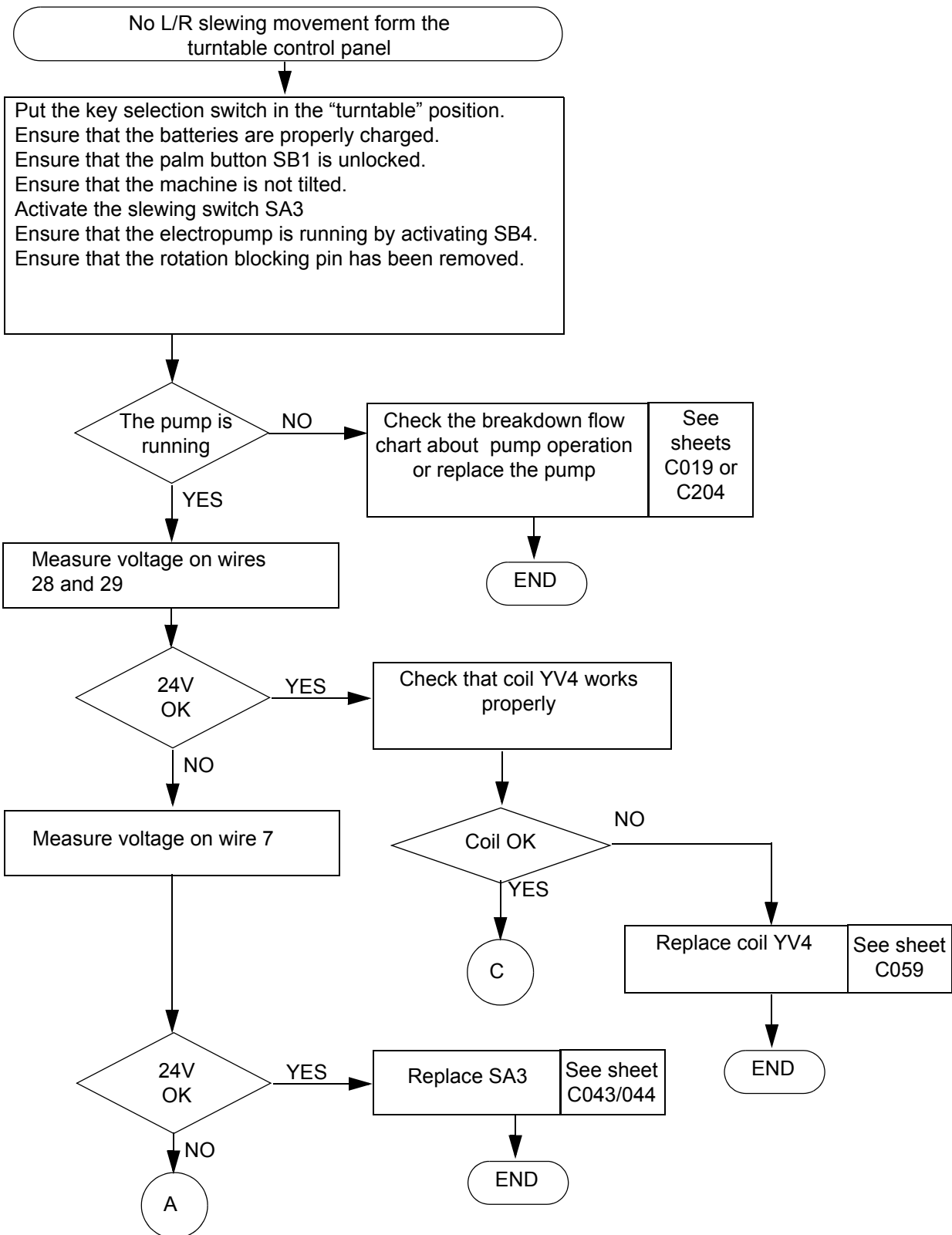

|             |  |           |
|-------------|--|-----------|
| Sheet DP150 | BREAKDOWN DETECTION FLOW CHART                           | Folio 2/4 |
|             | NO L/R SLEWING MOVEMENT FROM THE TURNTABLE CONTROL PANEL |           |

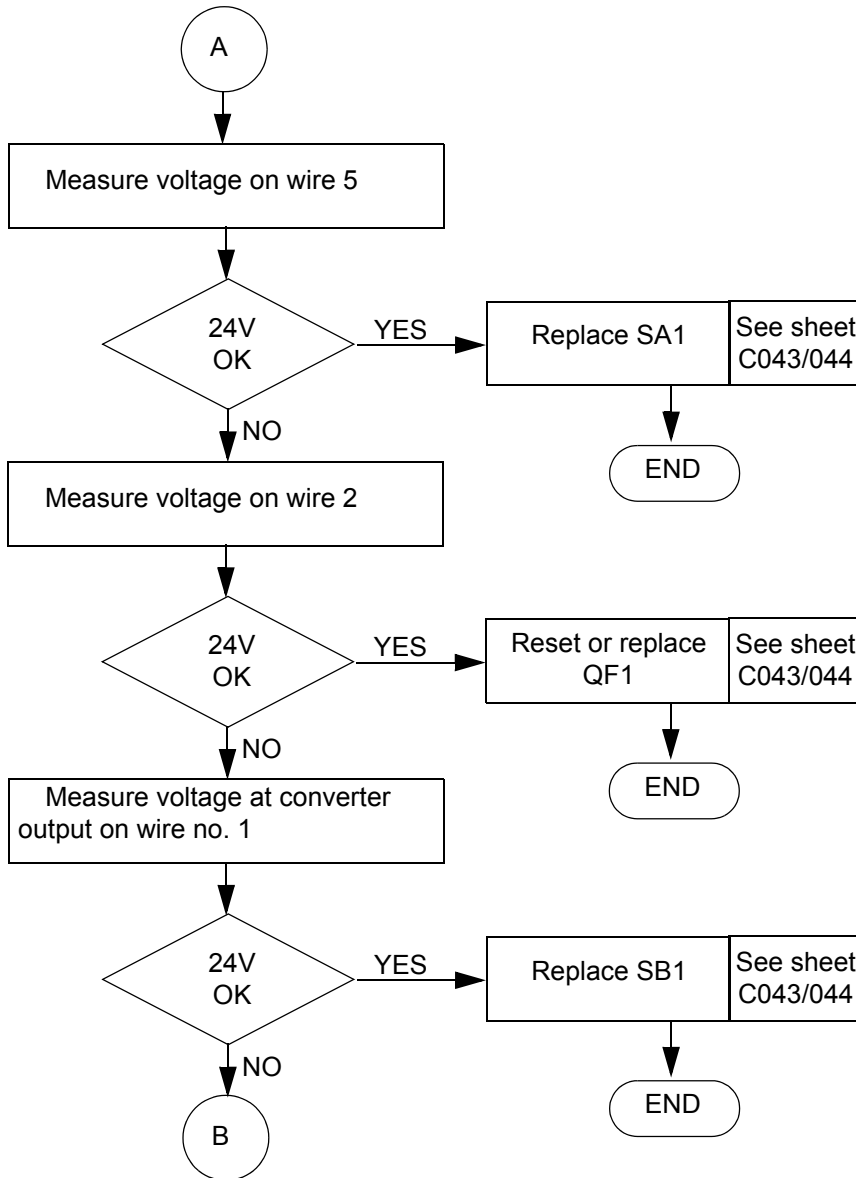

|             |  |           |
|-------------|--|-----------|
| Sheet DP150 | BREAKDOWN DETECTION FLOW CHART                           | Folio 3/4 |
|             | NO L/R SLEWING MOVEMENT FROM THE TURNTABLE CONTROL PANEL |           |

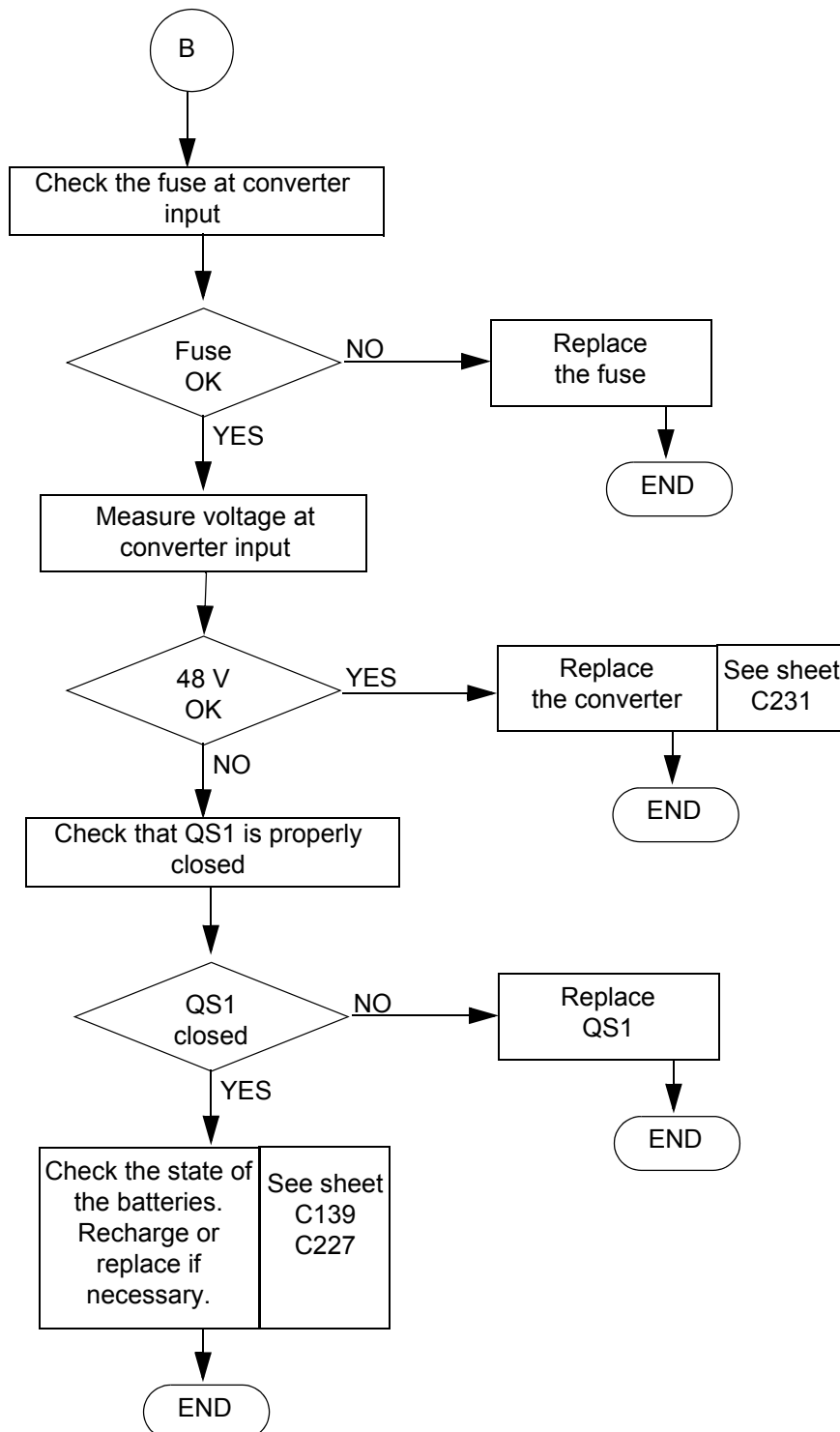

|             |   |           |
|-------------|---|-----------|
| Sheet DP150 | BREAKDOWN DETECTION FLOW CHART                              | Folio 4/4 |
|             | NO L/R SLEWING MOVEMENT<br>FROM THE TURNTABLE CONTROL PANEL |           |

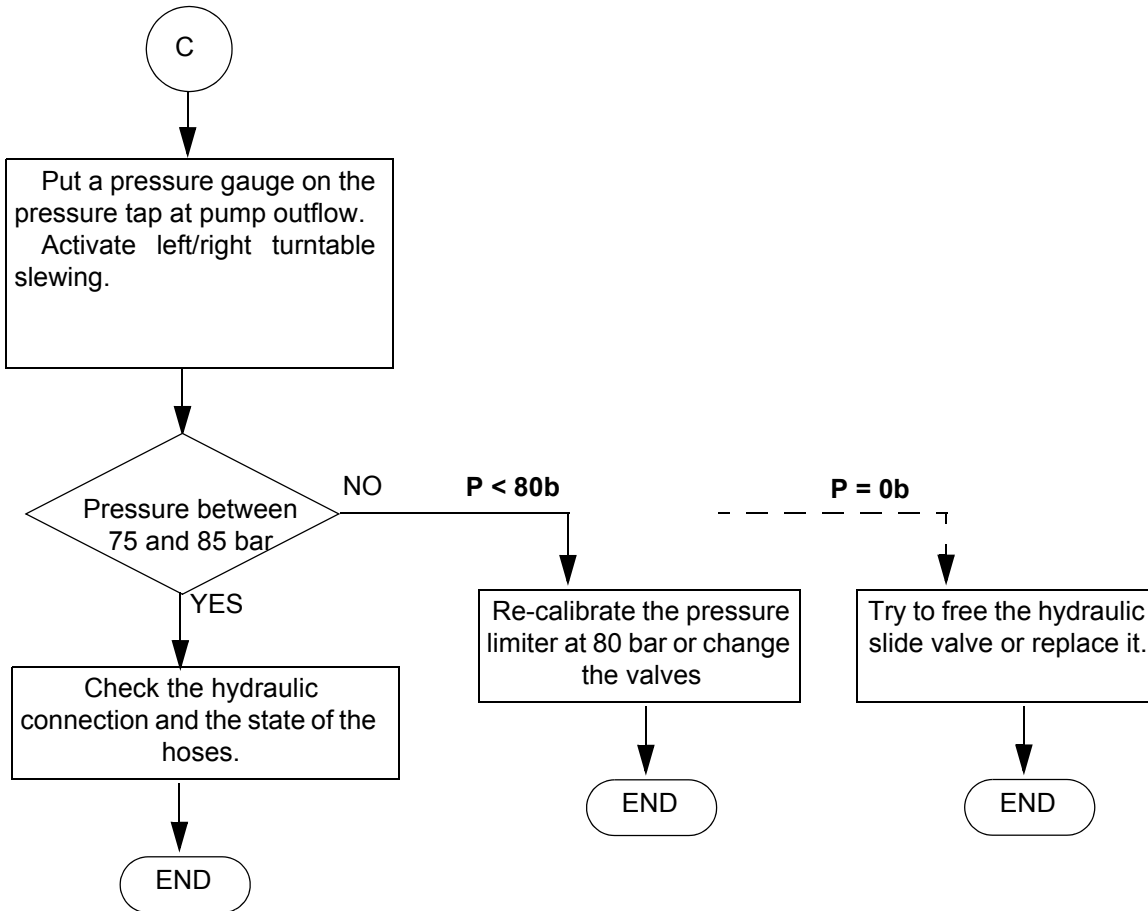

|             |  |           |
|-------------|--|-----------|
| Sheet DP151 | BREAKDOWN DETECTION FLOW CHART                                 | Folio 1/2 |
|             | THE ELECTROPUMP DOES NOT WORK FROM THE TURNTABLE CONTROL PANEL |           |

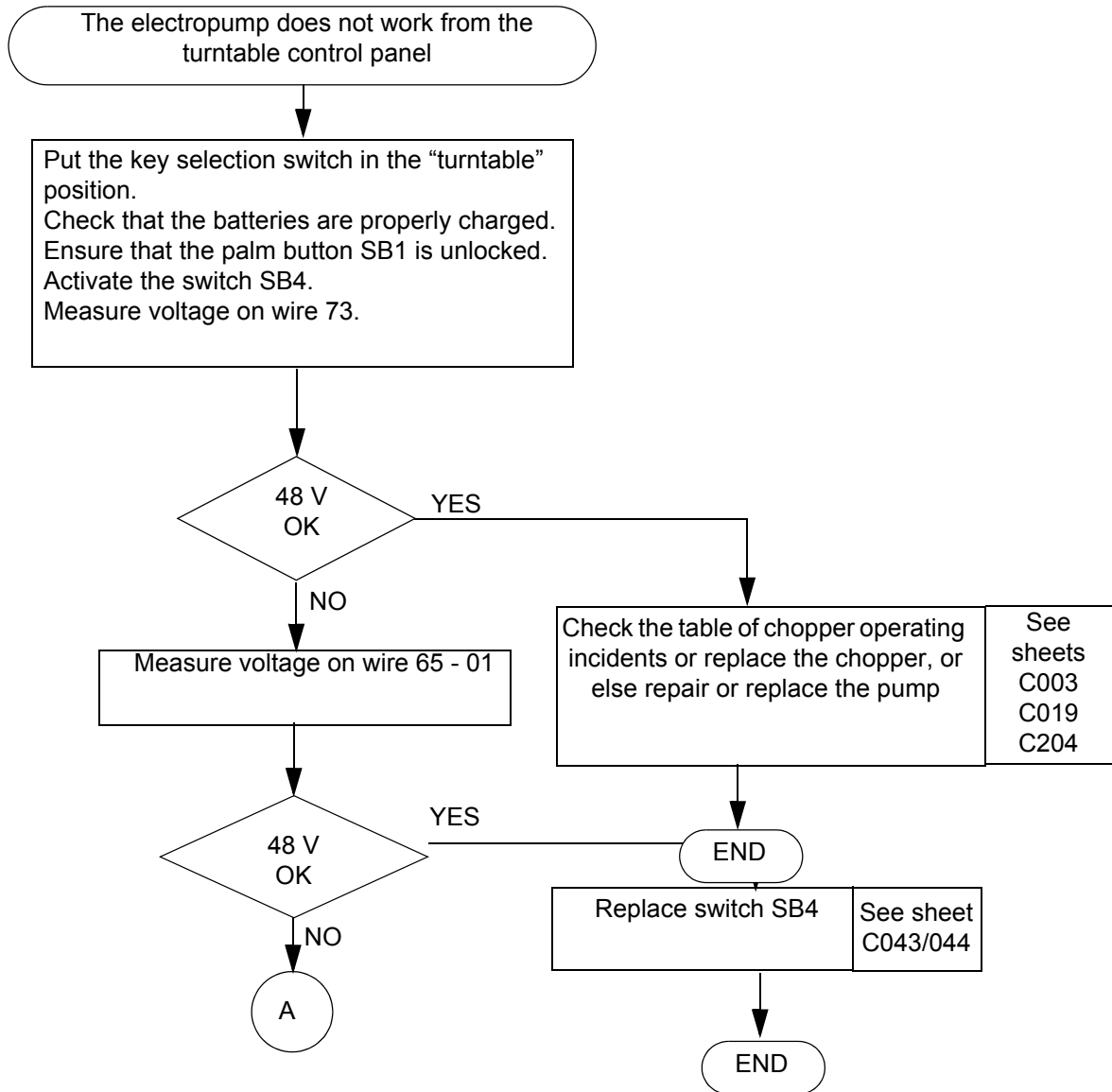

|             |  |           |
|-------------|--|-----------|
| Sheet DP151 | BREAKDOWN DETECTION FLOW CHART                                 | Folio 2/2 |
|             | THE ELECTROPUMP DOES NOT WORK FROM THE TURNTABLE CONTROL PANEL |           |

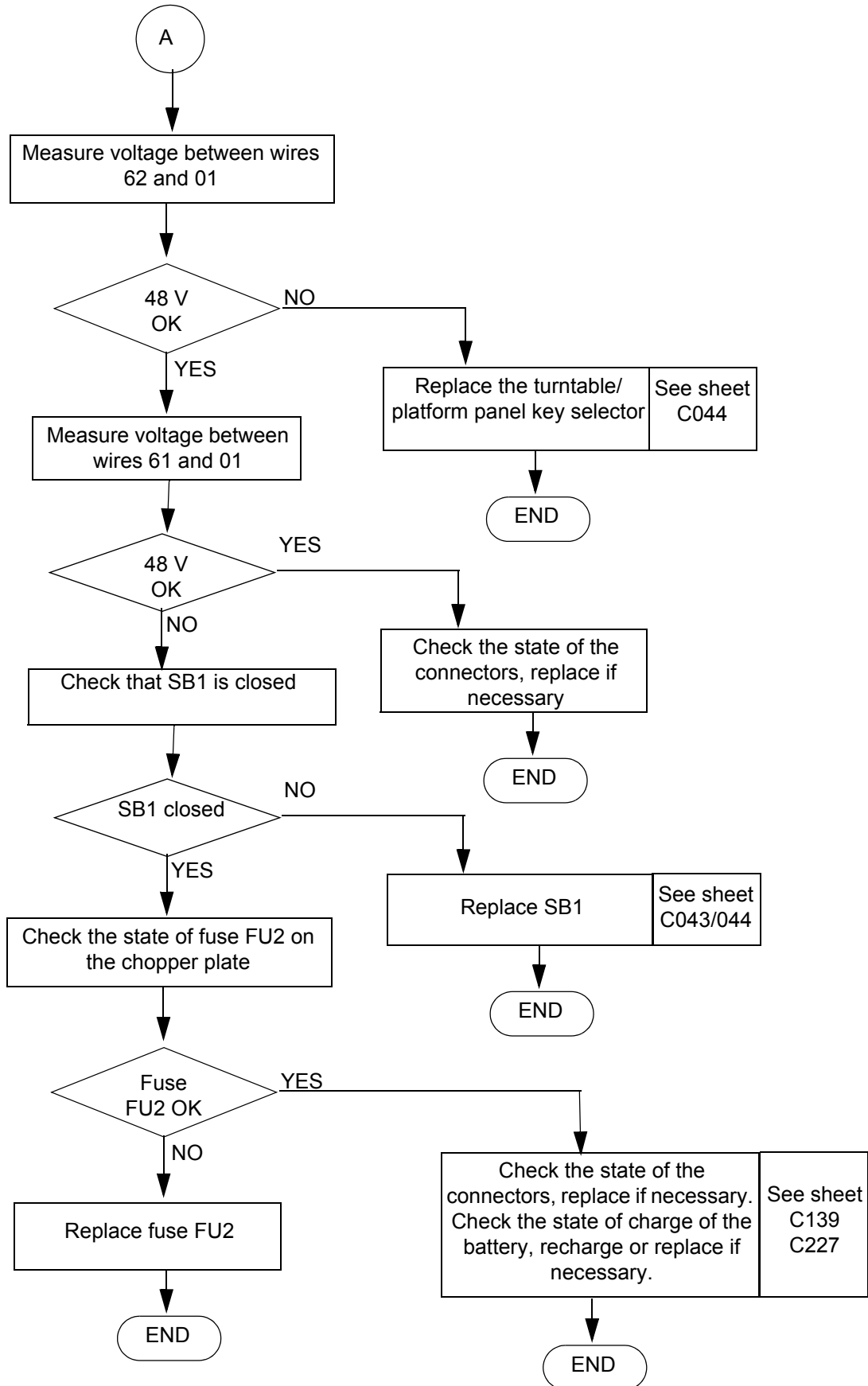

## 9 - CORRECTIVE MAINTENANCE PROCEDURES

List of corrective maintenance sheets:

| <i>Sheet no.</i> | <i>Description</i>  |
|------------------|---|
| SHEET C003       | Replacing the chopper   |
| SHEET C010       | Replacing a hose  |
| SHEET C019       | Replacing the motorpump unit                                      |
| SHEET C020       | Replacing a hydraulic block valve                                 |
| SHEET C039       | Replacing the tilt sensor   |
| SHEET C040       | Replacing the buzzer  |
| SHEET C041       | Replacing the tilt buzzer   |
| SHEET C043       | Changing an electric component on the top control panel           |
| SHEET C044       | Replacing an electric component on the bottom control panel       |
| SHEET C050       | Changing the turntable rotation hydraulic motor                   |
| SHEET C052       | Replacing the basket rotation hydraulic motor                     |
| SHEET C053       | Replacing the basket  |
| SHEET C054       | Replacing the weighing bearing                                    |
| SHEET C055       | Replacing the turntable rotation gearing                          |
| SHEET C056       | Replacing the hydraulic filter                                    |
| SHEET C059       | Relacing a coil   |
| SHEET C060       | Replacing the manual pump   |
| SHEET C063       | Replacing the printed circuit                                     |
| SHEET C064       | Replacing the fail-safe pedal                                     |
| SHEET C065       | Replacing a hydraulic unit (travel, steering or on/off movements) |
| SHEET C067       | Replacing an electrovalve   |
| SHEET C070       | Dismantling-reassembling the boom                                 |
| SHEET C071       | Dismantling-reassembling the lifting arm                          |
| SHEET C073       | Adjusting a pressure limiter                                      |
| SHEET C075       | Replacing the boom lifting cylinder                               |
| SHEET C078       | Replacing the arm lifting cylinder                                |
| SHEET C082       | Replacing a balancing valve - compensation function               |
| SHEET C139       | Charging traction batteries                                       |
| SHEET C204       | Replacing the hydraulic pump                                      |
| SHEET C208       | Replacing the turntable emergency stop button                     |
| SHEET C220       | Replacing the counterweight                                       |
| SHEET C221       | Replacing a cover   |
| SHEET C222       | Replacing a manipulator   |
| SHEET C223       | Replacing the steering cylinder                                   |

| <i>Sheet no.</i> | <i>Description</i>                             |
|------------------|--|
| SHEET C224       | Replacing a steering pivot                     |
| SHEET C226       | Replacing a travel reducer                     |
| SHEET C227       | Removing - reinstalling the traction batteries |
| SHEET C228       | Changing the turntable rotation gearing        |
| SHEET C229       | Replacing the slew ring                        |
| SHEET C230       | Replacing the accumulator                      |
| SHEET C231       | Changing the converter                         |
| SHEET C232       | Changing the pressure switches                 |

|            |                              |           |
|------------|------------------------------|-----------|
| SHEET C003 | CORRECTIVE MAINTENANCE SHEET | Sheet 1/2 |
|            | REPLACING THE SPEED VARIATOR |           |

**1 - Preliminary operations**

- Put the machine in the low position.
- Cut off the electric power supply (see § 6.3, page 26).
- Disconnect the + and - terminals of the batteries to isolate the electric circuit.

**2 - Removing the speed variator**

- Disconnect the speed variator's electric connections.
- Remove the speed variator (1).

**3 - Replacing the speed variator**

- Put the speed variator back into place and secure with the fixing screws.
- Reconnect the speed variator's electric connections.
- Reconnect the + and - terminals of the batteries.
- Put the machine back in the operational configuration.

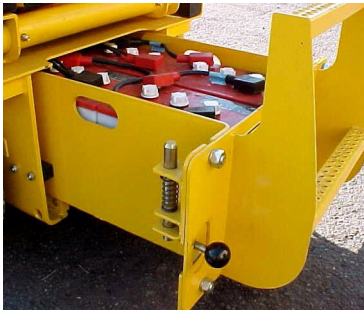

Compact



Optimum

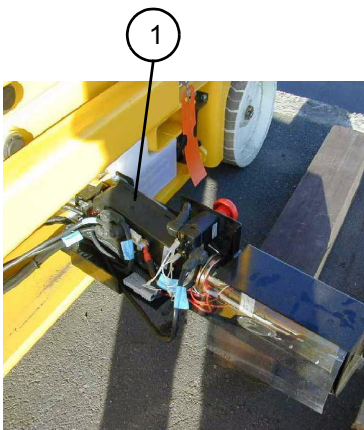

Compact

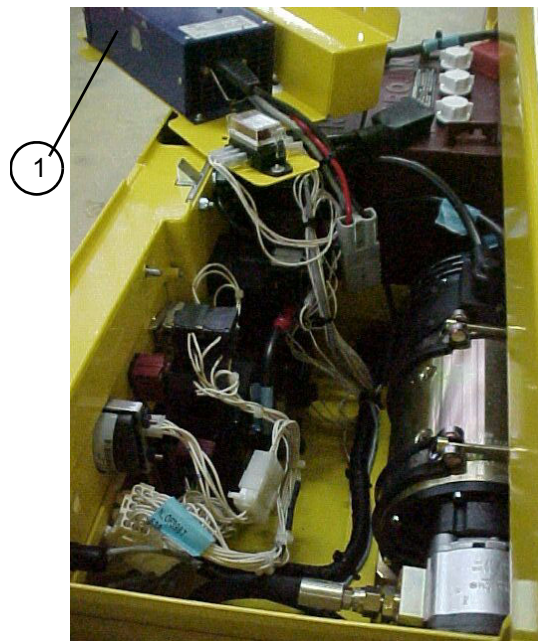

Optimum

|            |                              |           |
|------------|------------------------------|-----------|
| SHEET C003 | CORRECTIVE MAINTENANCE SHEET | Sheet 2/2 |
|            | REPLACING THE SPEED VARIATOR |           |



Star 22 J / Star 8

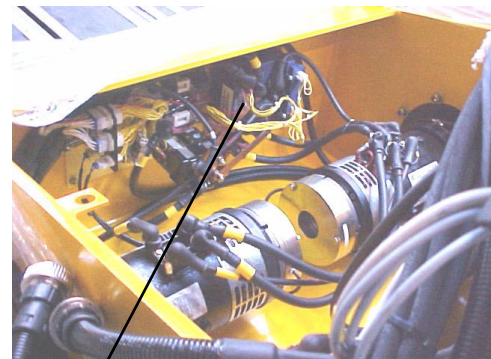
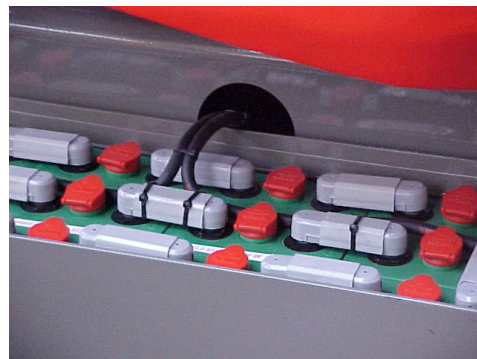

HA12IP / HA33JE

|            |                              |           |
|------------|------------------------------|-----------|
| Sheet C010 | CORRECTIVE MAINTENANCE SHEET | Folio 1/1 |
|            | REPLACING A HYDRAULIC HOSE   |           |

---

 **Caution!**  
**Ensure that the oil is not too hot.**

---



---

 **Caution!**  
**Use a container to collect the oil to avoid pollution of the environment.**

---

### 1 - Preliminary operations

- Put the machine in the maintenance configuration (see § 6.3, page 48).
- Switch off the electric power supply (see § 6.4, page 49).
- If necessary, close the shut-off valve or empty the hydraulic tank.

### 2 - Removing a hydraulic hose

- Disconnect the hose from the equipment to which it is connected.

*NB:*            *Unscrew the hose slowly to release residual hydraulic pressure.*

- Protect the equipment holes with caps.

### 3 - Remounting a hydraulic hose

- Reconnect a new hydraulic hose (§ 2.3.4 - Tightening torque of hydraulic hoses, page 16).
- Put the machine back in the operational configuration.
- Make a few movements implementing the hose in question to purge the hydraulic circuit.
- Check the level of the hydraulic oil tank.



|            |                              |           |
|------------|------------------------------|-----------|
| SHEET C019 | CORRECTIVE MAINTENANCE SHEET | Sheet 1/2 |
|            | REPLACING THE MOTOR PUMP SET |           |

### 1 - Preliminary operations

- Put the machine in the maintenance configuration (see § 6.2, page 25).
- Cut off the electric power supply (see § 6.3, page 26).

**Caution!**  
**Ensure that oil temperature is not too high.**

**NB:** *Lift the platform using a gantry crane or fork-lift truck*

### 2 - Removing the motor pump set

- Remove the upper inspection flap (for **Compact** machines).
- Mark and disconnect the motor's electric connections (1).
- Mark and disconnect the hydraulic pump's hoses (3).
- Fit caps to the hoses.
- Remove the fixing collars (2) from the motor pump set and remove the motor pump set.
- Remove the hydraulic pump's suction and backflow flanges (4).

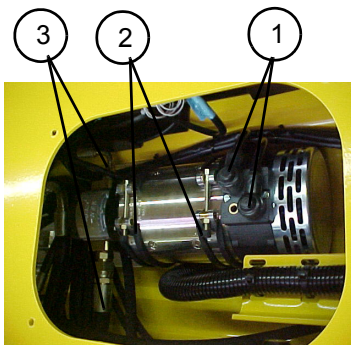

### 3 - Replacing the motor pump set

- Put the suction and backflow flanges equipped with new seals on a motor pump set.
- Put the motor pump set into place and secure with the collars.
- Reconnect the hydraulic hoses to the pump according to the marks made when dismantling.
- Reconnect the electric connections to the motor according to the marks made when dismantling.
- Close the inspection flap (for **Compact** machines).
- Put the machine back into the operational configuration.
- Perform several lifting cycles to purge the hydraulic circuit.
- Check the oil level in the hydraulic oil tank.

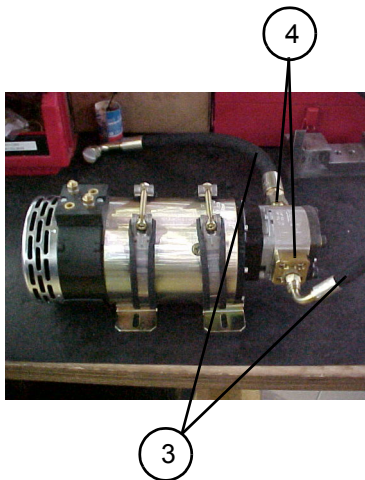

|  |                              |           |
|--|------------------------------|-----------|
|  | CORRECTIVE MAINTENANCE SHEET | Sheet 2/2 |
|  |                              |           |

|            |                                   |           |
|------------|-----------------------------------|-----------|
| SHEET C020 | CORRECTIVE MAINTENANCE SHEET      | Sheet 1/2 |
|            | REPLACING A HYDRAULIC BLOCK VALVE |           |

**1 - Preliminary operations**

- Put the machine in the maintenance configuration (see § 6.2, page 25).
- Cut off the electric power supply (see § 6.3, page 26).

**Caution!**  
*Ensure that oil temperature is not too high.*

**2 - Removing a valve from the hydraulic block**

- Unscrew the fixing screws (3) and take out the hydraulic block (4) if necessary to make access easier.
- Open the valve concerned.
- Unscrew the base (2) of the valve (1) and remove from the hydraulic block.
- Fit a cap to the hydraulic block hole to protect it.

**3 - Replacing a valve in the hydraulic block**

- Screw a new valve onto the hydraulic block.
- Put the valve back into its initial state.
- Fix the hydraulic block on with the fixing screws (3).
- Put the machine back into the operational configuration.
- Make several travel movements to purge the hydraulic circuit.

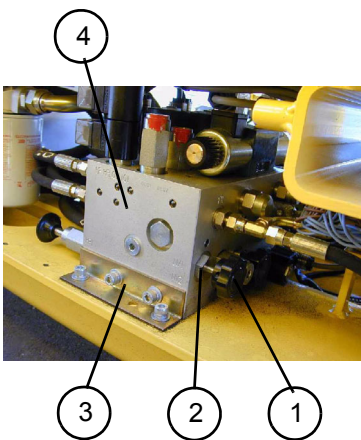

Compact

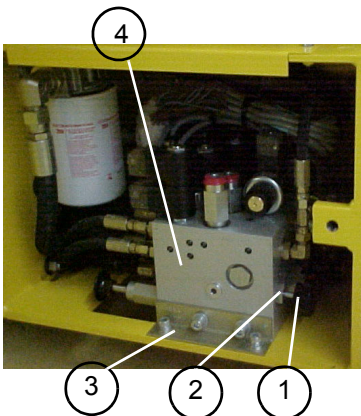

Optimum

|  |                              |           |
|--|------------------------------|-----------|
|  | CORRECTIVE MAINTENANCE SHEET | Sheet 2/2 |
|  |                              |           |

|            |                              |           |
|------------|------------------------------|-----------|
| Sheet C039 | CORRECTIVE MAINTENANCE SHEET | Folio 1/1 |
|            | CHANGING THE TILT SENSOR     |           |

 **Caution!**  
**Do not use the machine during maintenance operations.**

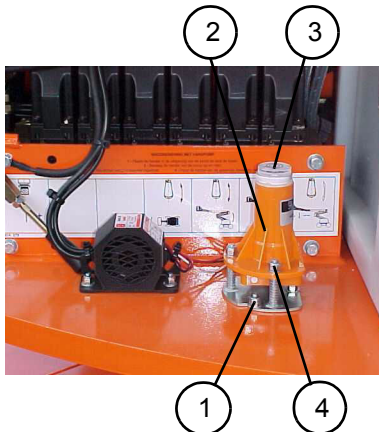

HA16/18PX - HA46/51 JRT

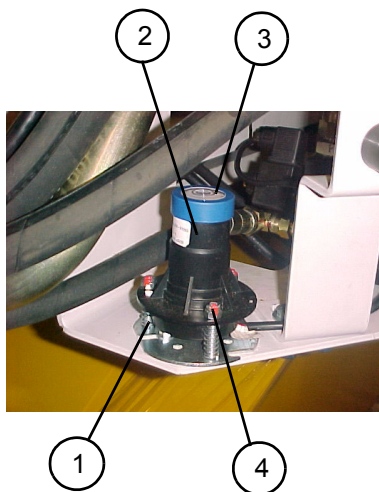

HA16/18PX New design  
 HA46/51JRT New Design

 **Caution!**  
**The buzzer should be audible from the basket.**

**1 - Preliminary operations**

- Put the machine on a flat surface with zero slope.
- Put the machine into the maintenance configuration (see corresponding paragraph).
- Switch off electric power (see corresponding paragraph).

**2 - Removing the tilt sensor**

- Mark and disconnect the electric connections of the tilt sensor.
- Remove the tilt sensor (2) by unscrewing the fixing bolts (1).

**3 - Installing the tilt sensor**

- Put a new tilt sensor into place and fix using the fixing bolts (1).
- Reconnect the electric connections according to the marks made during dismantling.
- Place a spirit level on the top surface of the tilt sensor and set the adjustment screws (4) so that the tilt sensor is level.

**NB:** *The spirit level (3) is built into certain tilt sensors.*

- Put the machine back into the operational configuration.

**4 - Tilt sensor operating test**

- Extend the machine.

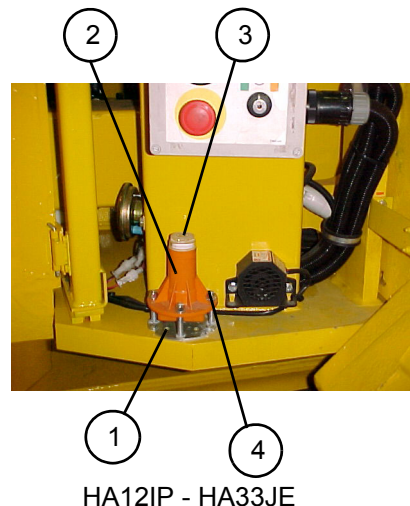

HA12IP - HA33JE



|            |                              |           |
|------------|------------------------------|-----------|
| Sheet C040 | CORRECTIVE MAINTENANCE SHEET | Sheet 1/1 |
|            | CHANGING THE HORN            |           |

 **Caution!**  
*Do not use the machine during maintenance operations.*

**1 - Preliminary operations**

- Switch off electric power (see corresponding paragraph).

**2 - Removing the horn**

- Mark and disconnect the electric connections from the horn (1).
- Remove the horn, by unscrewing the fixing bolts (2).

**3 - Installing the horn**

- Put the horn back into place and fix with the fixing bolt.
- Reconnect the electric connections according to the marks made during dismantling.

**4 - Test**

- Select the top control panel and switch on machine power.
- Put the machine back into the operational configuration.
- Activate the horn switch from the platform control panel and check that the horn sounds.

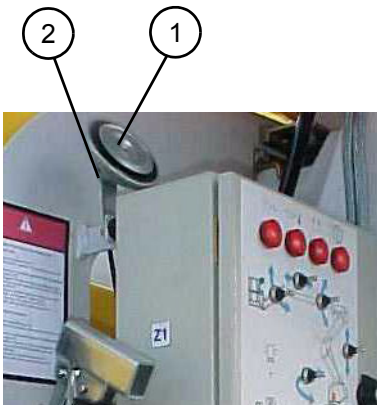

HA16 - PX / HA18 PX / HA 465 RT



Star 22J / Star 8

 **Caution!**  
*The horn should be audible from the basket.*

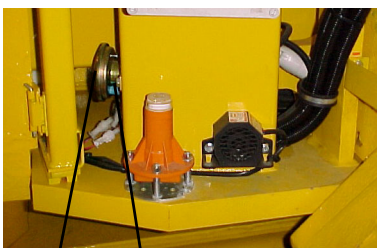

HA12IP - HA33JE

|  |                              |  |
|--|------------------------------|--|
|  | CORRECTIVE MAINTENANCE SHEET |  |
|  |                              |  |

|            |                                 |           |
|------------|---------------------------------|-----------|
| Sheet C041 | CORRECTIVE MAINTENANCE SHEET    | Folio 1/1 |
|            | CHANGING THE TILT SENSOR BUZZER |           |

 **Caution!**  
Do not use the machine during maintenance operations.

HA16/18PX - HA46/51JRT

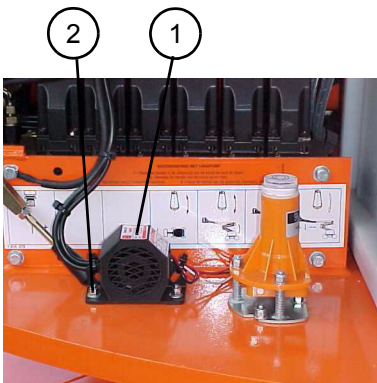

HA16/18PX New design  
HA46/51JRT New Design

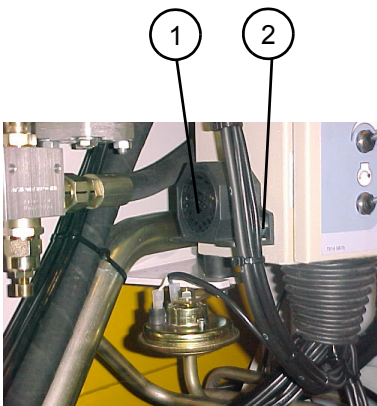

 **Caution!**  
The buzzer should be audible from the basket.

**1 - Preliminary operations**

- Switch off electric power (see corresponding paragraph).

**2 - Removing the buzzer**

- Mark and disconnect the buzzer's electric connections (1).
- Remove the buzzer by unscrewing the fixing bolts (2).

**3 - Installing the buzzer**

- Put the buzzer back into place and fix with the fixing bolts.
- Reconnect the electric connections according to the marks made during dismantling.

**4 - Test**

- Put the machine back into the operational configuration.
- Extend the machine, tilt the tilt sensor and check that the buzzer sounds.

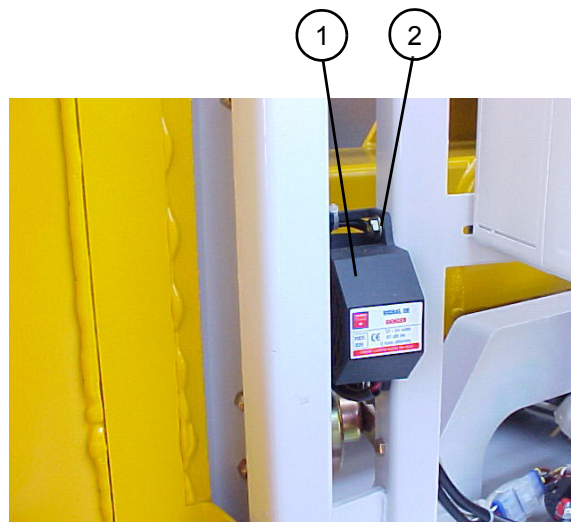

HA12IP - HA33JE

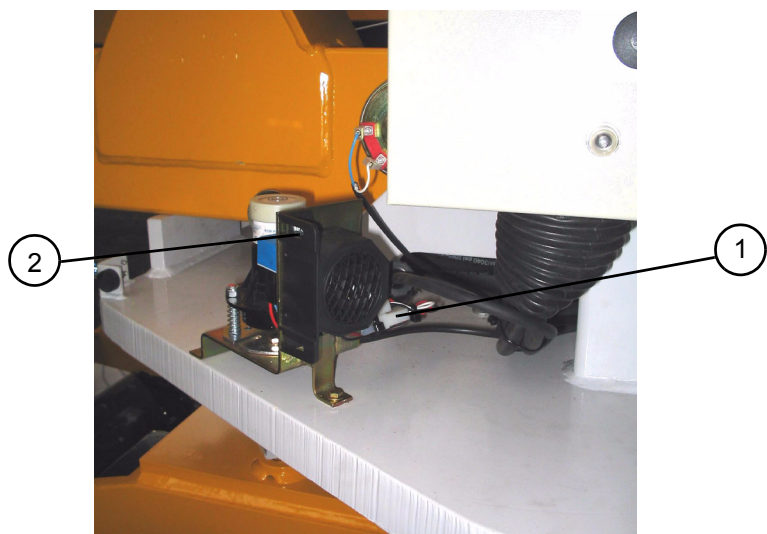

HA15I - HA43E



|            |   |           |
|------------|---|-----------|
| Sheet C043 | CORRECTIVE MAINTENANCE SHEET                            | Folio 1/1 |
|            | CHANGING AN ELECTRIC COMPONENT ON THE TOP CONTROL PANEL |           |

 **Caution!**  
**Do not use the machine during maintenance operations.**

### 1 - Preliminary operations

- Put the machine in the maintenance configuration (see corresponding paragraph).
- Switch off electric power (see corresponding paragraph).
- Disconnect the «-» then «+» terminals of the starter battery.

### 2 - Removing a component from the top control panel

- Remove the closing plate (1) by removing the four fixing screws (4).
- Mark and disconnect the electric connections (3) of the component to be replaced (2).
- Remove the component.

### 3 - Installing a component in the top control panel

- Put a new component and seal into place on the front panel of the top control panel.

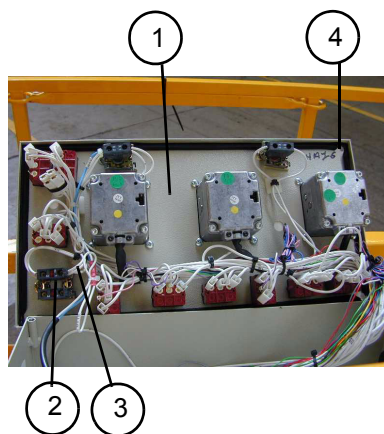

**NB:** *In the case of a lever switch, adjust the position of the fixing nut and counter-nut so that the switch lever's articulation pin is at the same level as the seal, to ensure tightness.*

- Reconnect the electric connections according to the marks made during dismantling.
- Fix the closing plate using the four fixing screws.
- Reconnect the « + » then « - » terminals of the battery.
- Put the machine back into the operational configuration.
- Perform the function corresponding to the replaced component to check that it works properly.

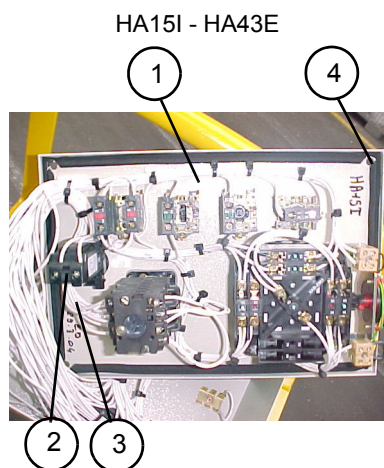



|            |  |           |
|------------|--|-----------|
| Sheet C044 | CORRECTIVE MAINTENANCE SHEET                               | Folio 1/1 |
|            | CHANGING AN ELECTRIC COMPONENT ON THE BOTTOM CONTROL PANEL |           |

 **Caution!**  
**Do not use the machine during maintenance operations.**

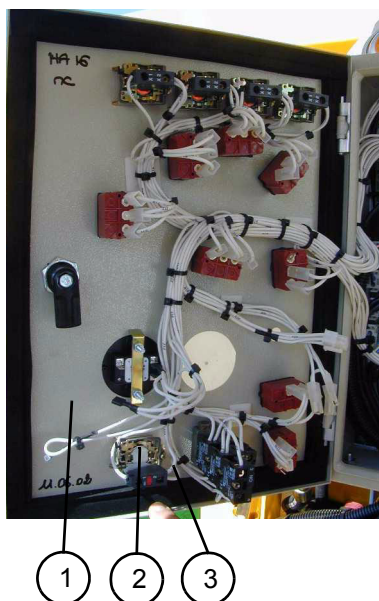

**1 - Preliminary operations**

- Put the machine in the maintenance configuration (see corresponding paragraph).
- Switch off electric power (see corresponding paragraph).
- Disconnect the «-» then «+» terminals to isolate the circuit.

**2 - Removing a component from the bottom control panel**

- Open the door of the bottom control panel (1).
- Mark and disconnect the electric connections (3) of the component to be replaced (2).
- Remove the component.

**3 - Installing a component in the bottom control panel**

- Put a new component and seal into place on the front panel of the bottom control panel.

*NB: In the case of a lever switch, adjust the position of the fixing nut and counter-nut so that the switch lever's articulation pin is at the same level as the seal, to ensure tightness.*

- Reconnect the electric connections according to the marks made during dismantling.
- Close the door of the bottom control panel.
- Reconnect the « + » then « - » terminals of the battery.

**4 - Test**

- Put the machine back into the operational configuration.
- Perform the function corresponding to the replaced component to check that it works properly.

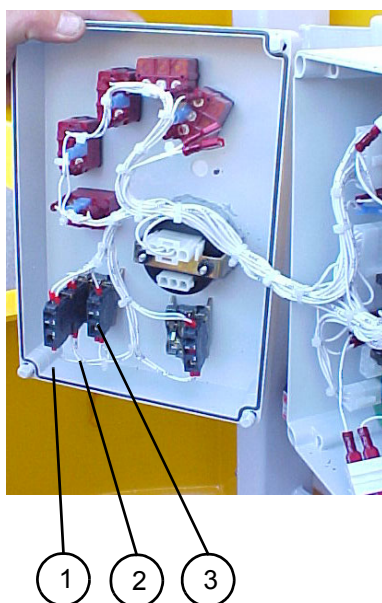

HA12IP - HA33JE

|            |   |  |
|------------|---|--|
| Sheet C044 | CORRECTIVE MAINTENANCE SHEET                                  |  |
|            | CHANGING AN ELECTRIC COMPONENT<br>ON THE BOTTOM CONTROL PANEL |  |

|            |   |           |
|------------|---|-----------|
| Sheet C050 | CORRECTIVE MAINTENANCE SHEET                    | Folio 1/1 |
|            | CHANGING THE TURNTABLE ROTATION HYDRAULIC MOTOR |           |



**Caution!**

**Ensure that the oil is not too hot.**



**Caution!**

**Put the turntable rotation blocking pin into place.**



**Caution!**

**Use a container to collect oil to prevent pollution of the environment.**



**Caution!**

**It is essential to put the component in slings before dismantling/re-assembling it.**

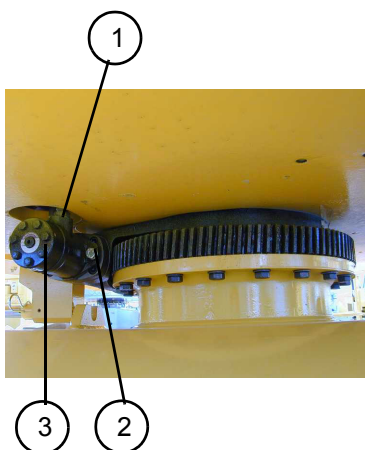

### 1 - Preliminary operations

- Put the machine in the maintenance configuration (see corresponding paragraph).
- Switch off electric power (see corresponding paragraph).

### 2 - Removing the hydraulic motor

- Mark and disconnect the hoses (1) of the hydraulic motor (3).

**NB:** *Unscrew the hoses slowly to release residual hydraulic pressure.*

- Fit caps to the hoses.
- Place a wedge under the hydraulic motor.
- Remove the hydraulic motor by removing its fixing bolts (2).

### 3 - Installing the hydraulic motor

- Put a new hydraulic motor into place.
- Fix the hydraulic motor using fixing bolts equipped with new spring washers.
- Re-connect the hydraulic hoses according to the marks made during dismantling.
- Put the machine back into the operational configuration.
- Remove the turntable rotation blocking pin.
- Make several turntable rotation movements to purge the hydraulic circuit.
- Check the level of the hydraulic oil tank.

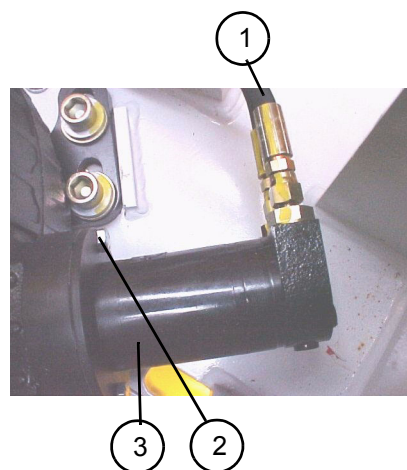

HA12IP - HA33JE

|  |                              |  |
|--|------------------------------|--|
|  | CORRECTIVE MAINTENANCE SHEET |  |
|  |                              |  |

|            |  |           |
|------------|--|-----------|
| Sheet C052 | CORRECTIVE MAINTENANCE SHEET                 | Folio 1/1 |
|            | CHANGING THE BASKET ROTATION HYDRAULIC MOTOR |           |

 **Caution!**  
**Ensure that the oil is not too hot.**

 **Caution!**  
**Use a container to collect oil to prevent pollution of the environment.**

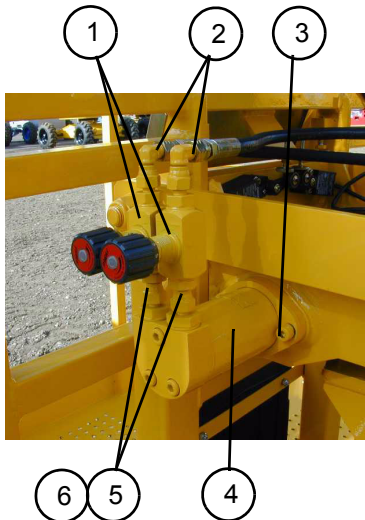

### 1 - Preliminary operations

- Put the machine in the maintenance configuration (see corresponding paragraph).
- Switch off electric power (see corresponding paragraph).

### 2 - Removing the hydraulic motor

- Mark and disconnect the hoses (2) from the hydraulic motor (4).

**NB:** *Unscrew the hoses slowly to release residual hydraulic pressure.*

- Fit caps to the hoses.
- Remove the flow limiters (1) by unscrewing the unions (5) and adapters (6).
- Remove the hydraulic motor by unscrewing its fixing screws (3).

### 3 - Installing the hydraulic motor

- Replace the flow limiters if necessary.
- Put a new hydraulic motor into place.
- Fix the hydraulic motor using fixing screws equipped with new grower washers.
- Screw the unions, adapters and flow limiters onto the motor (tightening torque 70 Nm or 52 lb.ft).
- Reconnect the hydraulic hoses according to the marks made during dismantling (tightening torque 70 Nm or 52 lb.ft).
- Put the machine back into the operational configuration.
- Make several platform rotation movements to purge the hydraulic circuit and adjust rotation speed using the flow limiter adjustment buttons (see Table of adjustment times).

**NEVER TO CLOSE THE FLOW LIMITERS.**

- Check the level of the hydraulic oil tank.



|            |                              |           |
|------------|------------------------------|-----------|
| Sheet C053 | CORRECTIVE MAINTENANCE SHEET | Folio 1/3 |
|            | CHANGING THE BASKET          |           |



**Caution!**

**It is essential to put the component in slings before dismantling/re-assembling it.**

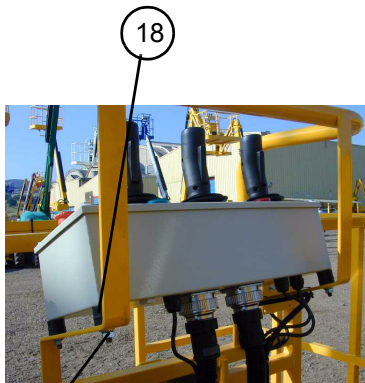

Standard control panel

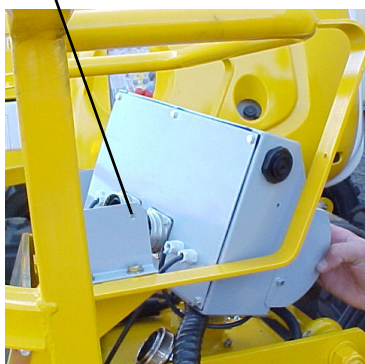

HA12IP/HA33JE control panel

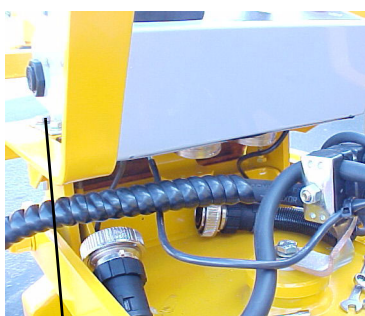

17

**1 - Preliminary operations**

- Put the machine in the maintenance configuration (see corresponding paragraph).
- Switch off electric power (see corresponding paragraph).
- Disconnect the « - » then « + » terminals of the starter battery.

**2 - Removing the platform**

- Disconnect the platform control panel electric wiring harness.
- Remove the control panel fixing screws (17).
- Remove the control panel and its silent blocks (18).
- Remove the platform's electric plug (19), if any, by unscrewing its fixing bolts.
- Put the platform in slings.
- Remove the pre-stressing stop by unscrewing the screw (1) and nut (2).

**Upper part**

- Remove the Nylstop nut (3) and its washer (4) on the platform side.
- Remove the stop pad (5) on the platform side.
- Remove the weighing articulation pin (6).

**Lower part**

- Remove the lower pivot pin (7) by removing its fixing screws (8) and washer (9).
- Remove the platform and retain the ball (10), the nylatron washer (11) and the stop (12).
- If necessary, unscrew the pre-stressing nut totally (13) as a safety measure, before performing any operation on the platform.

**3 - Installing the platform**

- Check the condition of the elastic parts and wearing parts, and replace if necessary (spring washers (14), collar rings (15), ring (16), nylatron washer (11), control panel silent blocks, circlips).

**Lower part**

- If necessary, adjust the pre-stressing system by tightening the pre-stressing nut (13), so that the washers are 108 mm (7 in) high (see figure 3).
- Put the platform into place, taking care to put the ball (10), nylatron washer (11) and stop (12) in the right places.
- Lubricate the bore and put the lower pivot (7) into place. Fix using the fixing screw (8) and washer (9).

**NB:** *Only use lubricants recommended by the manufacturer.*

**Upper part**

- Lubricate then put back the weighing articulation pin (6).
- Put back the stop tab (5).
- Install the Nylstop nut (3) and its washer (4).
- Adjust the stop for the pre-stressing system by tightening the screw (1) and the nut (2).
- Put the control panel into place on its silent blocks and fix using the screws equipped with new washers.
- Reconnect the control panel wiring harness.

|            |                              |           |
|------------|------------------------------|-----------|
| Sheet C053 | CORRECTIVE MAINTENANCE SHEET | Folio 2/3 |
|            | CHANGING THE BASKET          |           |



- If necessary, put the platform's electric plug back into place and fix using its fixing bolts equipped with new toothed washers.
- Reconnect the « + » then « - » terminals of the starter battery.
- Put the machine back into the operational configuration.
- Adjust the weighing contactors (see corresponding sheet).

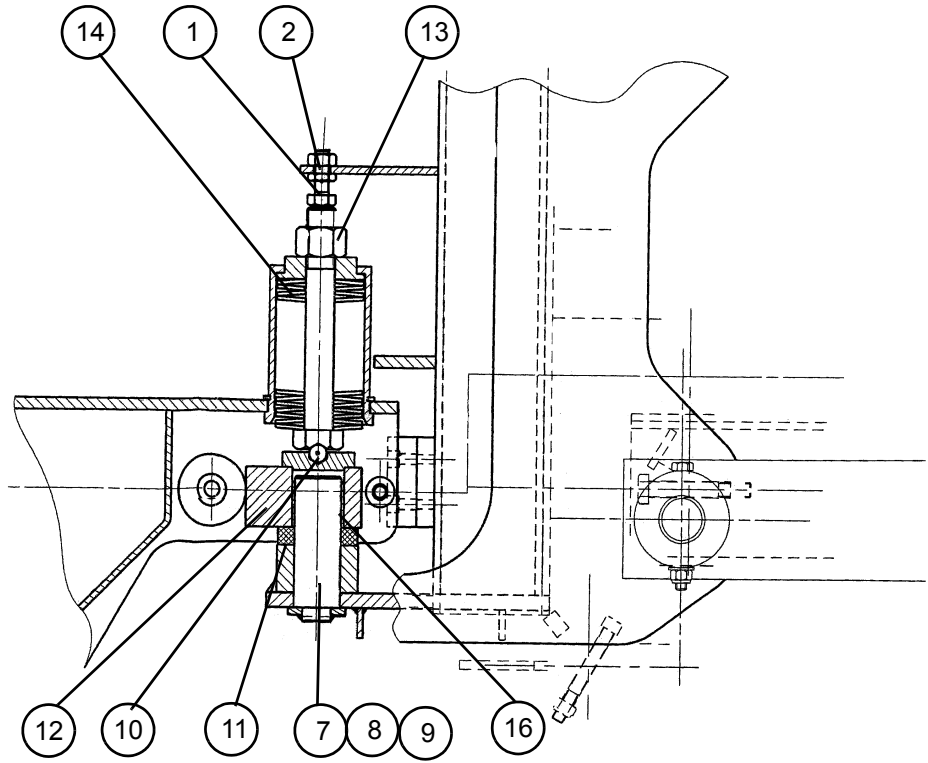
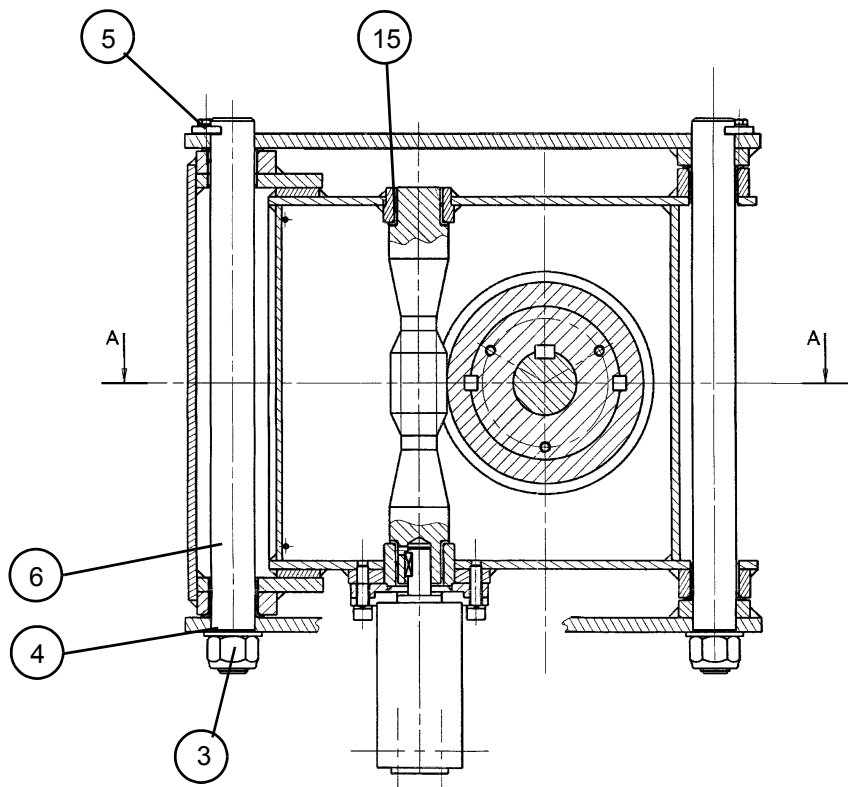
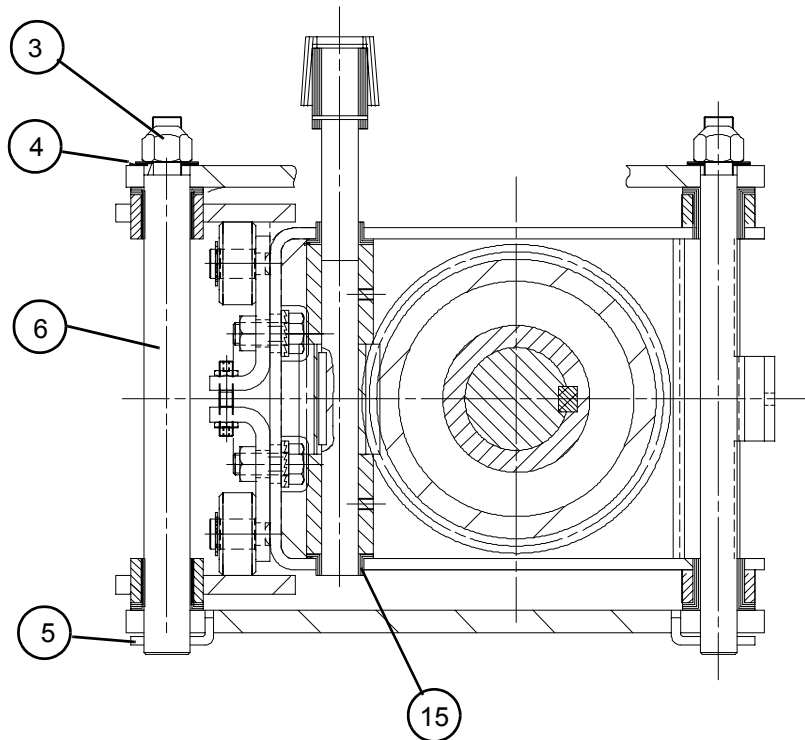

Figure 1



|            |                              |           |
|------------|------------------------------|-----------|
| Sheet C053 | CORRECTIVE MAINTENANCE SHEET | Folio 3/3 |
|            | CHANGING THE BASKET          |           |

Figure 3



X =

|                                   |                |
|-----------------------------------|----------------|
| HA16/18PX - HA46/51JRT =          | 108 mm / 4.3in |
| HA12IP - HA33JE =                 | 108 mm / 4.3in |
| H21T - HB62 =                     | 103 mm / 4.1in |
| H23T/TP - H25TP & HB68J - HB76J = | 108 mm / 4.3in |
| HA15I - HA43I =                   | 57 mm / 2.2in  |

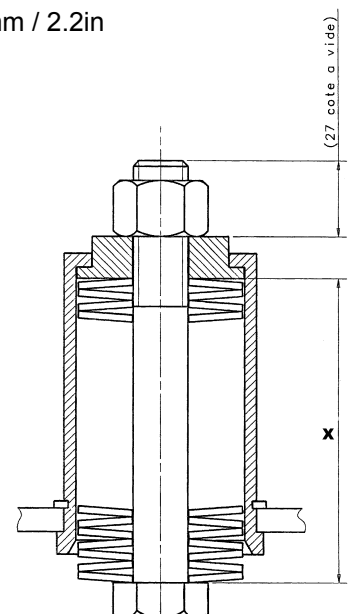

Figure 4



|            |  |           |
|------------|--|-----------|
| Sheet C054 | CORRECTIVE MAINTENANCE SHEET               | Folio 1/1 |
|            | CHANGING A WEIGHING SYSTEM ROLLING BEARING |           |

**1 - Preliminary operations**

- Put the machine in the maintenance configuration (see corresponding paragraph).
- Switch off electric power (see corresponding paragraph).
- Remove the basket (see corresponding sheet).

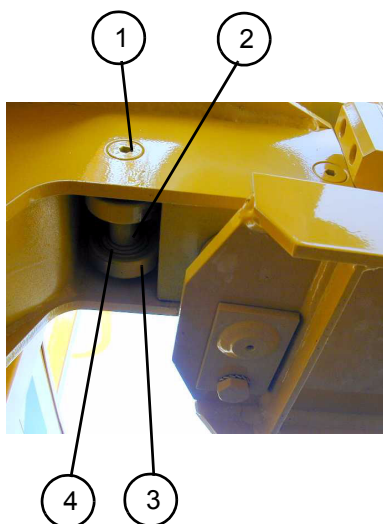

**2 - Removing the rolling bearing**

- Remove the screws (1) from the rolling bearing track.
- Remove the rolling bearing track (2).
- Remove the circlips (4), then the ball bearings (3).

**3 - Installing the rolling bearing**

- Put new rolling elements on the bearing track. Block in travel using the circlips.
- Lubricate the rolling bearings.

**NB:** *Only use lubricants recommended by the manufacturer.*

- Re-install the basket (see corresponding sheet).
- Put the machine back in the operational configuration.



|            |                               |           |
|------------|-------------------------------|-----------|
| Sheet C056 | CORRECTIVE MAINTENANCE SHEET  | Folio 1/1 |
|            | CHANGING THE HYDRAULIC FILTER |           |

 **Caution!**  
Ensure that the oil is not too hot.

 **Caution!**  
Use a container to collect oil to prevent pollution of the environment.

### 1 - Preliminary operations

- Put the machine in the maintenance configuration (see corresponding paragraph).
- Switch off electric power (see corresponding paragraph).
- Close the shut-off valve, if any. Otherwise, empty the hydraulic tank.

### 2 - Removing the hydraulic filter

- Disconnect the hydraulic filter hoses (1).

**NB:** *Unscrew the hoses slowly to release residual hydraulic pressure.*

- Fit caps to the hoses.
- Unscrew the fixing screws (2) and remove the hydraulic filter.
- Remove the two connectors (3) from the hydraulic filter.

### 3 - Installing the hydraulic filter

- Install the two connectors on a new hydraulic filter (see the table of tightening torque values).
- Put the equipped hydraulic filter back into place, respecting the oil flow direction and fix using the fixing screws.
- Reconnect the hydraulic hoses.
- Put the machine back into the operational configuration.
- Make several lifting cycles to purge the hydraulic circuit.



HA16/18PX - HA46/51JRT

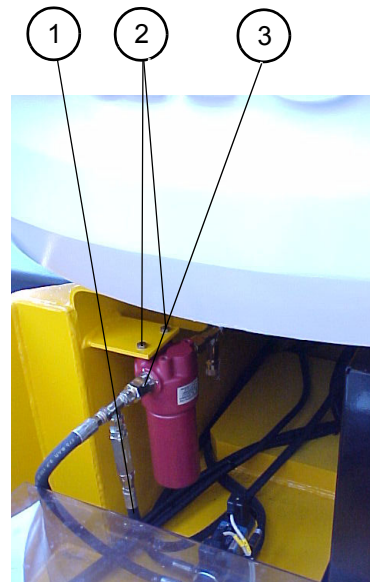

HA12IP - HA33JE



H14/16TPX - HB40/44J

|  |                              |           |
|--|------------------------------|-----------|
|  | CORRECTIVE MAINTENANCE SHEET | Folio 2/2 |
|  |                              |           |

|            |                              |           |
|------------|------------------------------|-----------|
| Sheet C059 | CORRECTIVE MAINTENANCE SHEET | Folio 1/1 |
|            | CHANGING A COIL              |           |

**1 - Preliminary operations**

- Put the machine in the maintenance configuration (see corresponding paragraph).
- Switch off electric power (see corresponding paragraph).

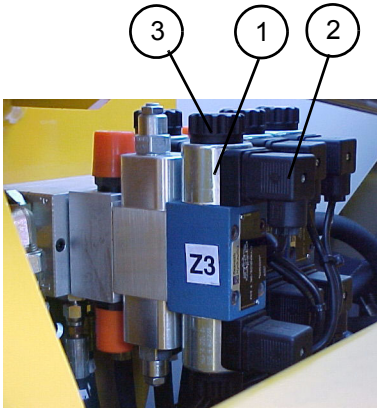

**2 - Removing a coil**

- Disconnect the electric connector (2) from the coil concerned.
- Unscrew the nut (3) and remove the coil (1).

**3 - Installing a coil**

- Put a new coil into place (1) and fix with the nut (3).
- Reconnect the electric connector (2) to the coil.
- Put the machine back into the operational configuration.
- Check proper operation by making the movement corresponding to the replaced coil.



|            |                              |           |
|------------|------------------------------|-----------|
| Sheet C060 | CORRECTIVE MAINTENANCE SHEET | Sheet 1/1 |
|            | CHANGING THE HAND PUMP       |           |

 **Caution!**  
 Use a container to collect oil  
 to prevent pollution of the  
 environment.

**1 - Preliminary operations**

- Put the machine in the maintenance configuration.

**2 - Removing the hand pump**

- Mark and disconnect the hydraulic hoses (2) from the hand pump (1).

*NB:* Unscrew the hoses slowly to release residual hydraulic pressure.

- Fit caps to the hoses.
- Remove the union pieces (3) from the hand pump.
- Remove the hand pump by removing its fixing bolts (5).

**3 - Installing the hand pump**

- Put a new hand pump into place and fix using the fixing bolts.
- Replace the non-return valve (6) if necessary.
- Install the union pieces on the pump.
- Reconnect the hydraulic hoses, according to the marks made during dismantling.
- Put the machine back into the operational configuration.
- Close the decompression valve (4).
- Perform an emergency operation to check that the hand pump works properly (see «Operation and Maintenance Instructions» manual).
- Open the decompression valve.



HA16 PX - HA18 PX / HA 465 RT



Star 22 J / Star 8

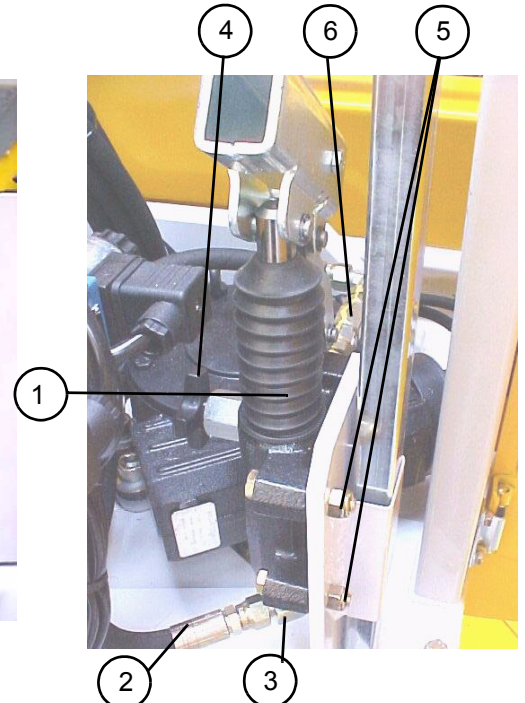

HA12IP / HA33JE

|  |                              |  |
|--|------------------------------|--|
|  | CORRECTIVE MAINTENANCE SHEET |  |
|  |                              |  |

|            |                              |           |
|------------|------------------------------|-----------|
| Sheet C063 | CORRECTIVE MAINTENANCE SHEET | Sheet 1/1 |
|            | CHANGING THE PRINTED CIRCUIT |           |

### 1 - Preliminary operations

- Put the machine in the maintenance configuration (see corresponding paragraph).
- Switch off electric power (see corresponding paragraph).
- Disconnect the « - » then « + » terminals of the starter battery.

### 2 - Removing the printed circuit

- Open the turntable electric box.
- Carefully mark and disconnect all the electric connections (1) of the printed circuit (2).
- Remove the U1 electronic module (4) (**except STAR, HA12IP and HA33JE**) (see corresponding sheet)
- Remove the bolts (3) fixing the board to the box and their sealing washers.
- Remove the printed circuit and silent-blocks equipping the fixing bolts.
- **STAR only** : disconnect the printed circuit's serial card.

### 3 - Installing the printed circuit

- Put a new printed circuit into place and fix using the bolts equipped with silent blocks, sealing rings and new toothed washers.
- **STAR only** : Install the printed circuit's serial card.
- Install the U1 electronic module (**except STAR, HA12IP and HA33JE**) (see corresponding sheet).
- Reconnect the electric connections according to the marks made during dismantling.
- Close the turntable box.
- Reconnect the « + » then « - » terminals of the starter battery.
- Put the machine back into the operational configuration.
- Test the printed circuit.

### 4 - Testing the printed circuit

- Perform the computer operating test (see «changing the U1 electronic module» sheet) (**except STAR, HA12IP and HA33JE**).

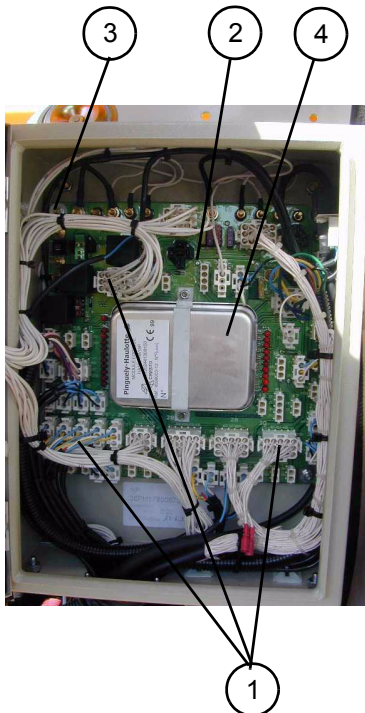

HA16 PX - HA18 PX / HA 465 RT

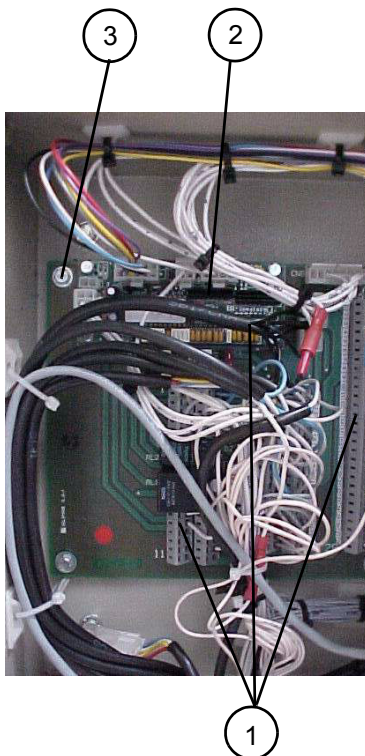

Star 22J / Star 8

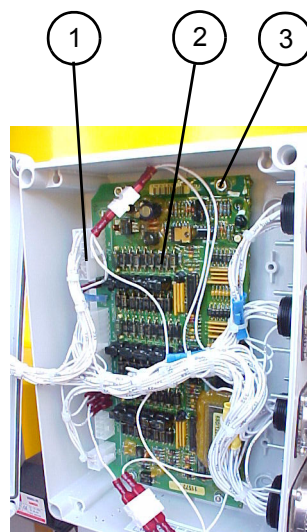

HA12IP-HA33JE

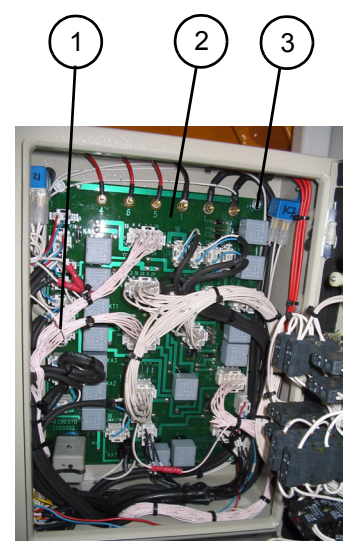

HA15I-HA43E

|  |                              |  |
|--|------------------------------|--|
|  | CORRECTIVE MAINTENANCE SHEET |  |
|  |                              |  |

|            |                              |           |
|------------|------------------------------|-----------|
| Sheet C064 | CORRECTIVE MAINTENANCE SHEET | Folio 1/1 |
|            | CHANGING THE FAIL-SAFE PEDAL |           |

**1 - Preliminary operations**

- Put the machine in the maintenance configuration (see corresponding paragraph).
- Switch off electric power (see corresponding paragraph).
- Disconnect the « - » then « + » terminals of the starter battery.



**2 - Removing the fail-safe pedal**

- Open the platform electric box.
- Mark and disconnect the electric connections (1) of the fail-safe pedal (2) in the box.
- Mark the pedal cabling path (1) along the vertical platform parts and then cut the fixing collars (3).
- Remove the pedal by removing the pedal's fixing bolts (4) and their washers.

**3 - Installing the fail-safe pedal**

- Put a new pedal into place and fix using the bolts and their washers.
- Reconnect the electric connections in the box, according to the marks made during dismantling.
- Close the platform box.
- Fix the electric cable to the vertical platform parts using collars.
- Reconnect the « + » then « - » terminals of the starter battery.
- Put the machine back into the operational configuration.
- Check that movements from the platform are possible only if the fail-safe pedal is pressed.



|            |  |           |
|------------|--|-----------|
| Sheet C065 | CORRECTIVE MAINTENANCE SHEET   | Folio 1/2 |
|            | CHANGING A HYDRAULIC BLOCK<br>(TRAVEL, STEERING OR ON/OFF MOVEMENTS) |           |

**Caution!**  
Ensure that the oil is not too hot.

**1 - Preliminary operations**

- Put the machine in the maintenance configuration (see corresponding paragraph).
- Switch off electric power (see corresponding paragraph).

**2 - Removing the hydraulic block**

- Mark and disconnect the hydraulic block's (1) electric connections (2).
- Mark and disconnect the hoses (4) of the hydraulic block.

**NB:** *Unscrew the hoses slowly to release residual hydraulic pressure.*

- Fit caps to the hoses.
- Place a wedge under the hydraulic block if necessary.
- Remove the hydraulic block by removing the fixing screws and washers (3).

**3 - Installing the hydraulic block**

- Put the hydraulic block into place and fix using screws equipped with new toothed washers.
- Reconnect the hydraulic hoses according to the marks made during dismantling.
- Reconnect the hydraulic block's electric connections, according to the marks made during dismantling.
- Put the machine back into the operational configuration.
- Make several movements using the hydraulic block concerned to purge the hydraulic circuit.
- Check the level in the hydraulic oil tank.

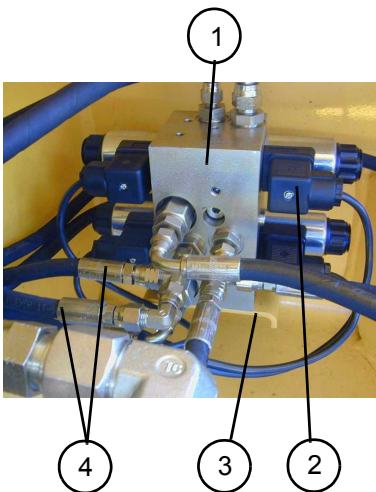

Steering block

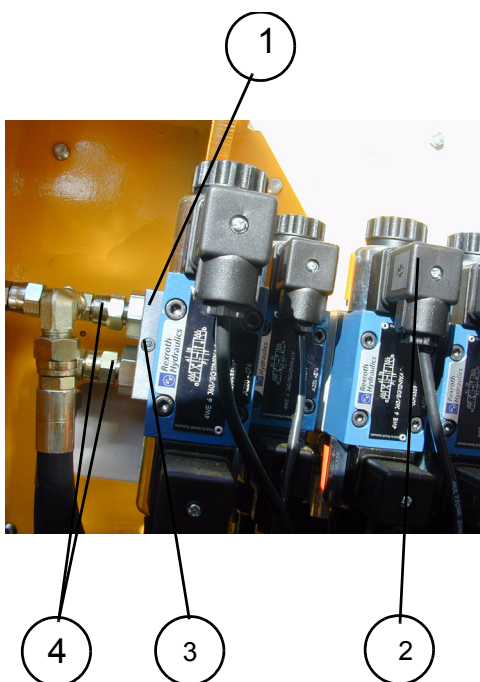

On/off movement block

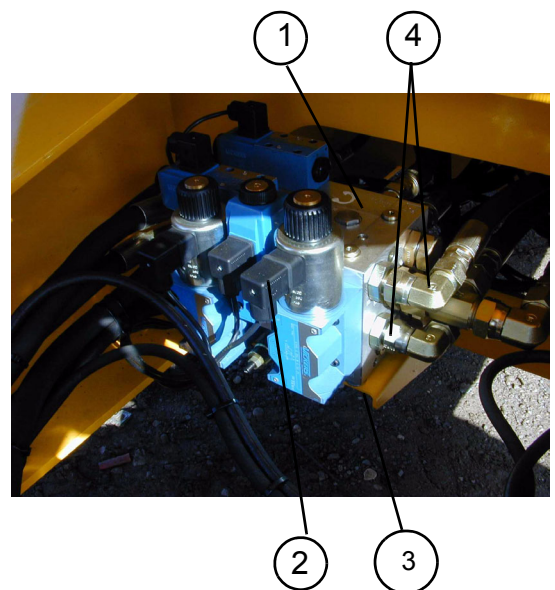

Travel block

|            |  |           |
|------------|--|-----------|
| Sheet C065 | CORRECTIVE MAINTENANCE SHEET   | Folio 2/2 |
|            | CHANGING A HYDRAULIC BLOCK<br>(TRAVEL, STEERING OR ON/OFF MOVEMENTS) |           |

|            |                              |           |
|------------|------------------------------|-----------|
| Sheet C067 | CORRECTIVE MAINTENANCE SHEET | Sheet 1/2 |
|            | CHANGING AN ELECTROVALVE     |           |

 **Caution!**  
Ensure that the oil is not too hot.

 **Caution!**  
Use a container to collect oil to prevent pollution of the environment.

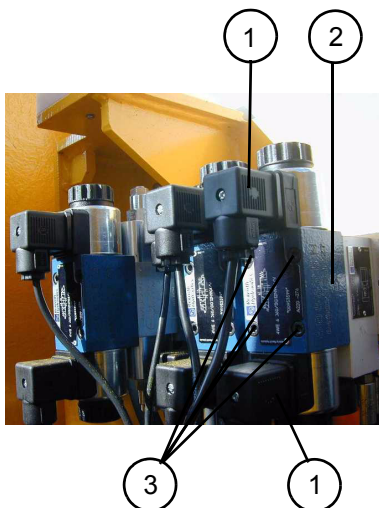

HA16 PX - HA18 PX / HA 465 RT

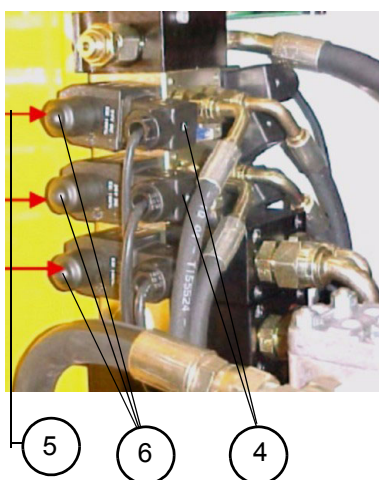

Star 22 J / Star 8

### 1 - Preliminary operations

- Put the machine in the maintenance configuration (see corresponding paragraph).
- Switch off electric power (see corresponding paragraph).

### 2 - Removing an electrovalve

- Mark and disconnect the electric connections(1) of the coils.
- Mark the installation position of the electrovalve on the block.
- Unscrew the four fixing screws (3) of the electrovalve (2) and remove.

### 3 - Installing an electrovalve

- Put a new electrovalve equipped with its seals into place and fix using the 4 screws, in the position of the electrovalve on the block. Tighten to the recommended torque (see corresponding paragraph).
- Reconnect the electrovalve's electric connections, according to the marks made during dismantling.
- Put the machine back into the operational configuration.
- Make several movement cycles using the replaced electrovalve to purge the hydraulic circuit.
- Check the level of the hydraulic oil tank.

### 4 - Dismantling/ reassembling an Oil Control coil

- Mark and disconnect the electric connections of the coils (4).
- Remove the protection (5) (plastic cap) from the end of the coil.
- Unscrew the nut (6) holding the coil and remove.
- Put a new coil into place.
- Put back the nut, protection and then reconnect the electric connections.

### 5 - Dismantling/reassembling an Oil Control slide valve

**The whole section (7) must be replaced, not just the slide valve (mark the defective sections in the stack).**

- Disconnect the wiring harnesses and the hydraulic hoses (plug them to prevent contamination).
- Remove the nuts (8) from the end of the three assembling tie rods (9).
- Remove the sections (7) one by one until the defective section is reached.
- Put a new section into place, then reassemble all sections.

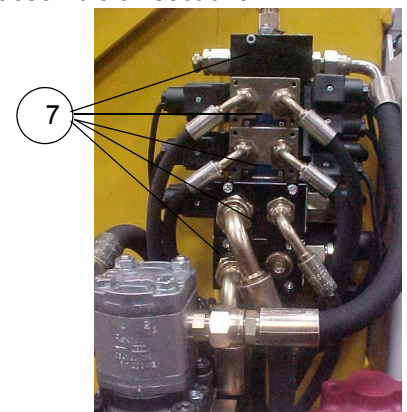
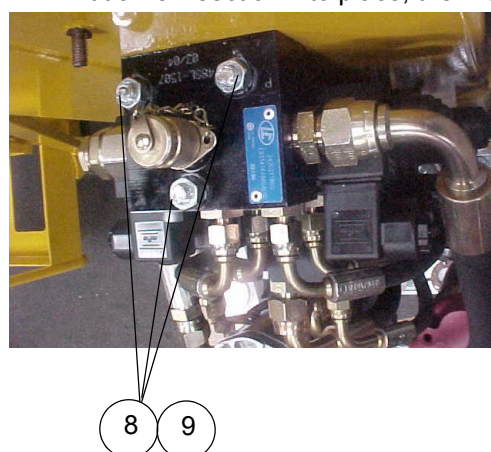

Star 8 / Star 22J

- Put the nuts back into place (tightening torque 20 / 21 N.m or 14.75 / 15.49 lb.ft).

**Throughout the dismantling/reassembly operation, take great care to preserve cleanliness and place the seals correctly at the interfaces between sections.**

|  |                              |  |
|--|------------------------------|--|
|  | CORRECTIVE MAINTENANCE SHEET |  |
|  |                              |  |

|            |                                      |           |
|------------|--------------------------------------|-----------|
| Sheet C070 | CORRECTIVE MAINTENANCE SHEET         | Folio 1/4 |
|            | DISMANTLING / RE-ASSEMBLING THE BOOM |           |

 **Caution!**  
Ensure that the oil is not too hot.

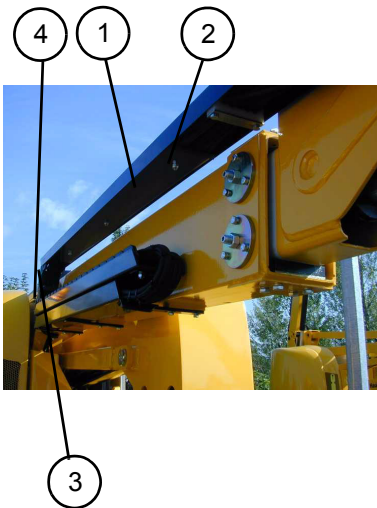

 **Caution!**  
Ensure that the lifting equipment is in good condition and of sufficient capacity.

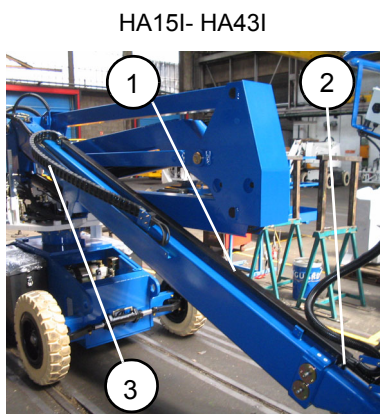

### 1 - Preliminary operations

- Lift the boom and arm sufficiently to enable access to the emitting compensation cylinder pin (12) and boom lifting cylinder pin (10).
- Place wedges under the arm to support it.
- Put the machine in the maintenance configuration (see corresponding paragraph).
- Switch off electric power (see corresponding paragraph).
- Put the boom in slings to prevent it tipping when the counterweight is removed.
- Remove the counterweight (see corresponding sheet).
- Remove the platform (see corresponding sheet).
- Remove the jib (see corresponding sheet). *(except HA15I-HA43E)*
- Remove the contactor SQ3 (see corresponding sheet).

### 2 - Removing the hoses

- Mark and disconnect the two hydraulic hoses from the emitting compensation cylinder (5), receiver compensation cylinder (6), telescoping cylinder and boom lifting cylinder (28).
- Fit caps to the hoses.
- Open the cable passage collars by removing their two fixing bolts.
- Remove the upper chain support (1) by removing its closing bolts and the closing pins (2).
- Remove the chain (3) by removing the two fixing bolts at each end.
- Remove the lower hose protection cover (4) by removing its fixing bolts. *(except HA15I-HA43E)*
- Remove all electric cables and hydraulic hoses passing along the length of the boom.

### 3 - Removing the receiver compensation cylinder

- Put the receiver compensation cylinder in slings (6).
- Remove the Mécanindus blocking pin (7) from the pin on the cylinder body side.
- Remove the cylinder pin (8), then remove the receiver compensation cylinder.

### 4 - Removing the boom

- Put the boom lifting cylinder (28) and emitting compensation cylinder (5) in slings.
- Remove the blocking clevis (9) from the boom lifting cylinder pin on the body side, then remove the pin (10).
- Remove the Mécanindus blocking pin (11) from the emitting compensation cylinder pin on the rod side, then remove the pin (12).
- Remove the blocking clevis from the boom articulation pin, then remove the pin (13).
- Remove the boom.

### 5 - Removing the telescope (14)

- Put the end of the telescope in slings.
- Remove the 6 pads (15) at the end of the boom drum (16).
- Remove the pin (17) from the telescoping cylinder (18) on the cylinder body side.
- Slide the telescope then put the telescope in slings to enable it to be removed.
- Remove the telescope (14).
- Remove the pin (19) from the telescoping cylinder pin on the rod side.
- Remove the pin (20), then remove the telescoping cylinder (18).

|            |                                      |           |
|------------|--------------------------------------|-----------|
| Sheet C070 | CORRECTIVE MAINTENANCE SHEET         | Folio 2/4 |
|            | DISMANTLING / RE-ASSEMBLING THE BOOM |           |

## 6 - Installing the telescope

*NB: Before re-assembling, check the condition of all the articulation pin rings and replace if necessary. Lubricate all bores before re-assembling the pins. Only use lubricants recommended by the manufacturer.*

- If necessary, replace the guide pads (21) on the telescoping cylinder, by removing their two fixing screws.
- If necessary, replace the four pads and adjustment wedges on the telescope. Remove the 4 screws for the upper and lower pads (22) and the two bolts for the side pads (23). Adjust the gap to 2 mm vertically and 1mm on each side laterally using the adjustment wedges (24) and (27).
- Put the telescoping cylinder in place inside the telescope.
- Install the telescoping cylinder pin and block using a new Mécanindus pin.
- Slide the telescope inside the boom drum, then install the telescoping cylinder pin on the body side.
- Replace the pads at the end of the boom drum if necessary and install. Adjust the gap using cup point screws (25) and tighten their counter-nuts (26).

*NB: If the gap between the telescope and the boom drum is greater than 7 mm (0ft 2in), insert a 5 mm (0ft 5in) wedge under the lower wedge, and change screw length.*

## 7 - Installing the boom

- Put the boom into place on the machine and fix to the boom support by re-installing the articulation pin.
- Install the fixing clevis and fix using the screw equipped with a new grower washer.
- Install the emitting compensation cylinder pin on the rod side and block using a new Mécanindus pin.
- Install the boom lifting cylinder pin on the body side.
- Put the pin blocking clevis into place and fix with its bolt.

*NB: Do not remove the sling from the boom to prevent tipping.*

## 8 - Installing the receiver compensation cylinder

- Put the receiver compensation cylinder into place.
- Put the articulation pin into place and block using a new Mécanindus pin.

## 9 - Installing the hoses

- Put all the electric cables and hydraulic hoses into place along the length of the boom. Pass them in the articulation chain.
- Put the lower hose protection cover into place and fix with the three fixing bolts.
- Install the chain and fix at either end using the 2 fixing bolts.
- Install the upper chain support and fix using its closing bolts and closing pins.
- Install the 4 cable and hose collars and fix with their 2 fixing bolts.
- Reconnect the 2 hydraulic hoses of the emitting compensation cylinder, receiver compensation cylinder, telescoping cylinder and boom lifting cylinder.

|            |                                      |           |
|------------|--------------------------------------|-----------|
| Sheet C070 | CORRECTIVE MAINTENANCE SHEET         | Folio 3/4 |
|            | DISMANTLING / RE-ASSEMBLING THE BOOM |           |

**10 - Additional operations**

- Re-install the contactor SQ3 (see corresponding sheet).
- Install the jib (see corresponding sheet).
- Install the platform (see corresponding sheet).
- Install the counterweight (see corresponding sheet).
- Put the machine back into the operational configuration.
- Remove the sling from the boom and the wedges under the arm.
- Extend the machine several times to test its operation and purge the hydraulic circuit.
- Check the level of the hydraulic circuit.

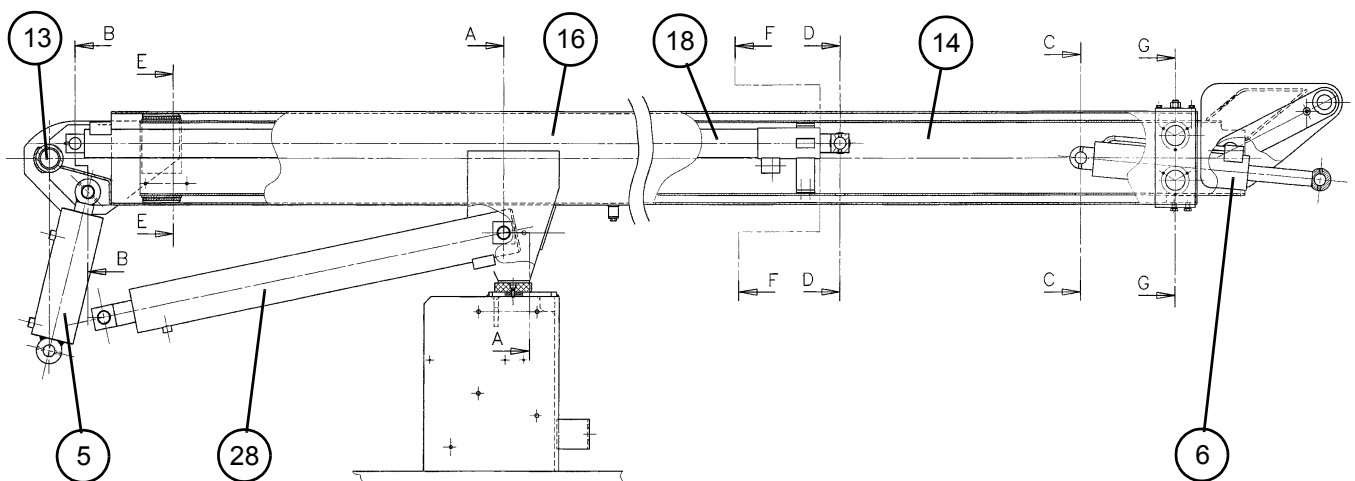

A - A

B - B

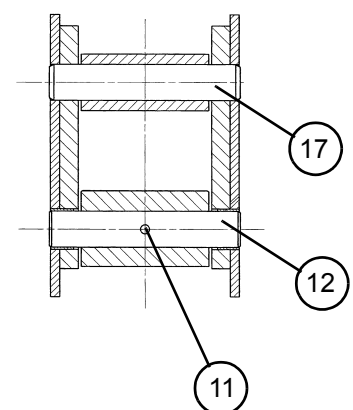
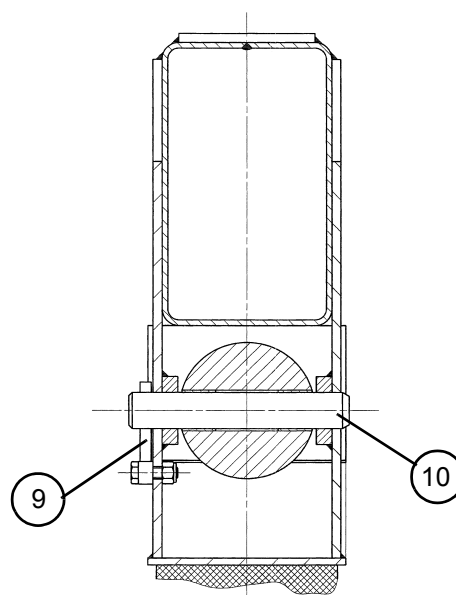

|            |                                      |           |
|------------|--------------------------------------|-----------|
| Sheet C070 | CORRECTIVE MAINTENANCE SHEET         | Folio 4/4 |
|            | DISMANTLING / RE-ASSEMBLING THE BOOM |           |

C - C

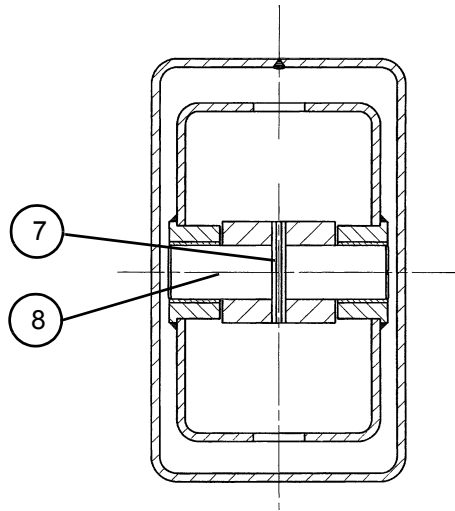

D - D

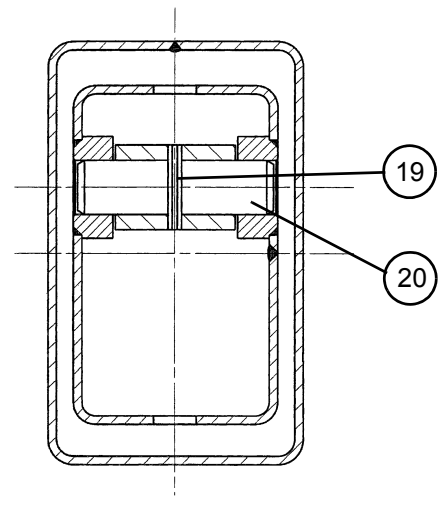

E - E

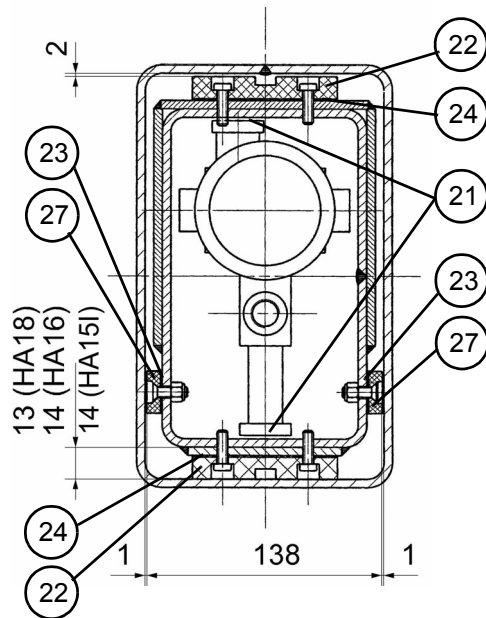

G - G

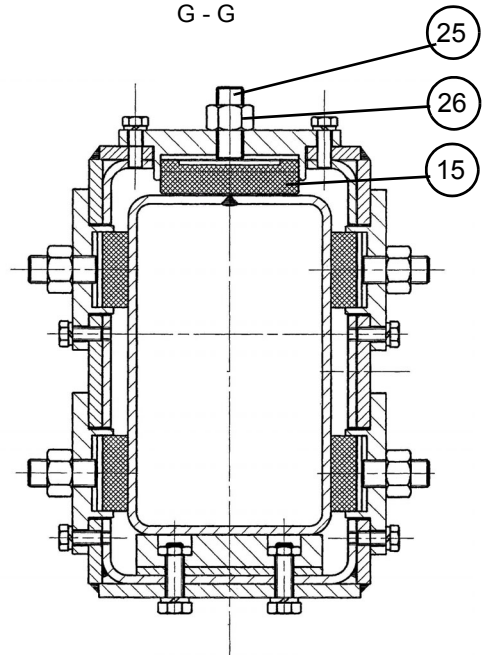

|            |   |           |
|------------|---|-----------|
| Sheet C071 | CORRECTIVE MAINTENANCE SHEET                | Folio 1/4 |
|            | DISMANTLING / RE-ASSEMBLING THE LIFTING ARM |           |

---

 **Caution!**  
**Check that the lifting equipment is in good condition and of sufficient capacity.**

---

### 1 - Preliminary operations

- Lift the arm sufficiently to enable access to the bottom tie rod/turntable pins (5) and the bottom arm /turntable pin (6), then place wedges under the arm to support it.
- Put the machine in the maintenance configuration (see corresponding paragraph).
- Switch off electric power (see corresponding paragraph).
- Put the boom in slings to prevent it tipping when the counterweight is removed.
- Remove the counterweight (see corresponding sheet).
- Remove the platform (see corresponding sheet).
- Remove the jib (see corresponding sheet).
- Remove the boom (see corresponding sheet).
- Remove the contactor SQ4 (see corresponding sheet).

### 2 - Removing the boom lifting cylinder and emitting compensation cylinder

*NB: After removing the boom, the boom lifting cylinder and emitting compensation cylinder are still linked to the lifting arm, which is why they must be removed.*

- Put the boom lifting cylinder and emitting compensation cylinder in slings.
- Remove the fixing screw and washer from the pin blocking clevis (1) of the boom lifting cylinder on the rod side, and remove the clevis.
- Remove the articulation pin (1) of the boom lifting cylinder and remove the cylinder.
- Remove the 2 stop washers from the pin (2) of the emitting compensation cylinder.
- Remove the pin blocking pin and then remove the pin (2).
- Remove the emitting compensation cylinder.

### 3 - Removing the lifting arm

- Mark and disconnect the two hydraulic hoses from the arm lifting cylinder (3).
- Fit caps to the hoses.
- Open the cable passage collar (4) by removing its two fixing bolts.
- Mark the path of the electric cables and hydraulic hoses passing along the arm and remove them.
- Put the arm in slings.
- Remove the pin stops of the 2 bottom tie rod/turntable pins (5) by removing their two fixing screws, then remove the 2 pins.
- Remove the pin stop from the turntable / bottom arm pin by removing its two fixing screws and then remove the pin (6).
- Remove the lifting arm.

### 4 - Dismantling the lifting arm

- Put the top tie rod (7), boom support (8) and intermediary support (9) into slings.
  - Remove the end piece washer, then remove the top tie rod / boom support articulation pin (10).
  - Remove the end piece washer, then remove the top tie rod / intermediary support articulation pin (11).
  - Remove the top tie rod (7).
  - Put the top arm into slings (12).
  - Remove the pin from the top arm/boom support pin (22), then remove the pin.
-

|            |   |           |
|------------|---|-----------|
| Sheet C071 | CORRECTIVE MAINTENANCE SHEET                | Folio 2/4 |
|            | DISMANTLING / RE-ASSEMBLING THE LIFTING ARM |           |

- Remove the boom support (8).
- Put the two bottom tie rods (13) and the top arm (12) into slings.
- Remove the two machined stops from the top arm/intermediary support/ bottom tie rod pin (14) by removing the four fixing screws, then remove the pin (14).
- Remove the two bottom tie rods (13).
- Put the arm lifting cylinder (3) in slings.
- Remove the male clevis blocking the pin (15) of the arm lifting cylinder on the rod side, by removing its fixing screw and washer, then remove the pin (15).
- Remove the top arm/connecting rod stop tab (16) by removing its two fixing screws and washers, then remove the pin (16).
- Remove the top arm (12).
- Remove the male clevis blocking the pin (17) of the arm lifting cylinder on the cylinder body side, by removing its fixing screw and washer, then remove the pin (17).
- Remove the arm lifting cylinder (3).
- Remove the bottom arm/connecting rod pin stop tab (18) by removing its two fixing screws and washers, then remove the pin (18).
- Remove the connecting rod (19).
- Remove the end piece washer, then remove the bottom arm / intermediary support articulation pin (20).
- Remove the intermediary support (9) from the bottom arm (21).

### 5 - Installing the lifting arm

**NB:** *Before re-assembling, check the condition of all the articulation pin rings and replace if necessary. Lubricate all bores before re-assembling the pins. Only use lubricants recommended by the manufacturer.*

- Put the intermediary support into place and fix on the bottom arm with the articulation pin
- Install the end piece washer fixed with its screw to block the pin.
- Put the connecting rod into place and fix on the bottom arm with the articulation pin.
- Install the pin stop tab and fix using its two fixing screws, equipped with new grower washers.
- Put the arm lifting cylinder into place and fix the body side of the cylinder to the bottom arm using the articulation pin.
- Install the male clevis blocking the cylinder pin and fix using its fixing screw, equipped with a new grower washer.
- Put the top arm into place and fix the arm lifting cylinder rod using the pin.
- Install the male clevis blocking the pin and fix using its fixing screw, equipped with a new grower washer.
- Fix the connecting rod to the top arm using the articulation pin.
- Install the top arm/connecting rod pin stop tab and fix using its two fixing screws equipped with new grower washers.
- Put the two bottom tie rods into place and fix the bottom tie rods, top arm and intermediary support using the pin.
- Install the two machined stops to block the pin with the four fixing screws.
- Put the boom support into place and fix to the top arm using the articulation pin. Block the pin using its pin.
- Put the top tie rod into place and fix to the intermediary support using the articulation pin.
- Place the end piece washer on the articulation pin and fix with its screw.
- Fix the top tie rod to the boom support using the articulation pin.
- Place the end piece washer on the articulation pin and fix using its screw.

|            |   |           |
|------------|---|-----------|
| Sheet C071 | CORRECTIVE MAINTENANCE SHEET                | Folio 3/4 |
|            | DISMANTLING / RE-ASSEMBLING THE LIFTING ARM |           |

### 6 - Installing the lifting arm

- Put the arm into place on the machine.
- Install the bottom arm / turntable pin and fix the pin stop with its two fixing screws to block it.
- Install the two bottom tie rod / turntable pins and fix the pin stops with their two fixing screws to block them.
- Put back into place all the electric cables and hydraulic hoses passing along the arm.
- Install the cable collars and fix with the two fixing bolts.
- Reconnect the two hydraulic hoses of the arm lifting cylinder.

### 7 - Installing the boom lifting cylinder and emitting compensation cylinder

*NB:* Install the boom lifting cylinder and the emitting compensation cylinder if you want to continue to re-assembly the boom.

- Put the emitting compensation cylinder into place and fix to the boom support with the articulation pin.
- Put in a new pin blocking pin.
- Install the two pin stop washers and fix with their fixing screws.
- Put in place the boom lifting cylinder and fix to the boom support using the articulation pin.
- Install the pin blockig clevis and fix using its fixing screw, equipped with a new grower washer.

### 8 - Additional operations

- Re-install the contactor SQ4 (see corresponding sheet).
  - Install the boom (see corresponding sheet).
  - Install the jib (see corresponding sheet).
  - Install the platform (see corresponding sheet).
  - Install the counterweight (see corresponding sheet).
  - Put the machine back into the operational configuration.
  - Remove the sling from the boom and the wedges under the arm.
  - Extend the machine several times to test its operation and purge the hydraulic circuit.
  - Check the level of the hydraulic circuit.
-

|            |   |           |
|------------|---|-----------|
| Sheet C071 | CORRECTIVE MAINTENANCE SHEET                | Folio 4/4 |
|            | DISMANTLING / RE-ASSEMBLING THE LIFTING ARM |           |

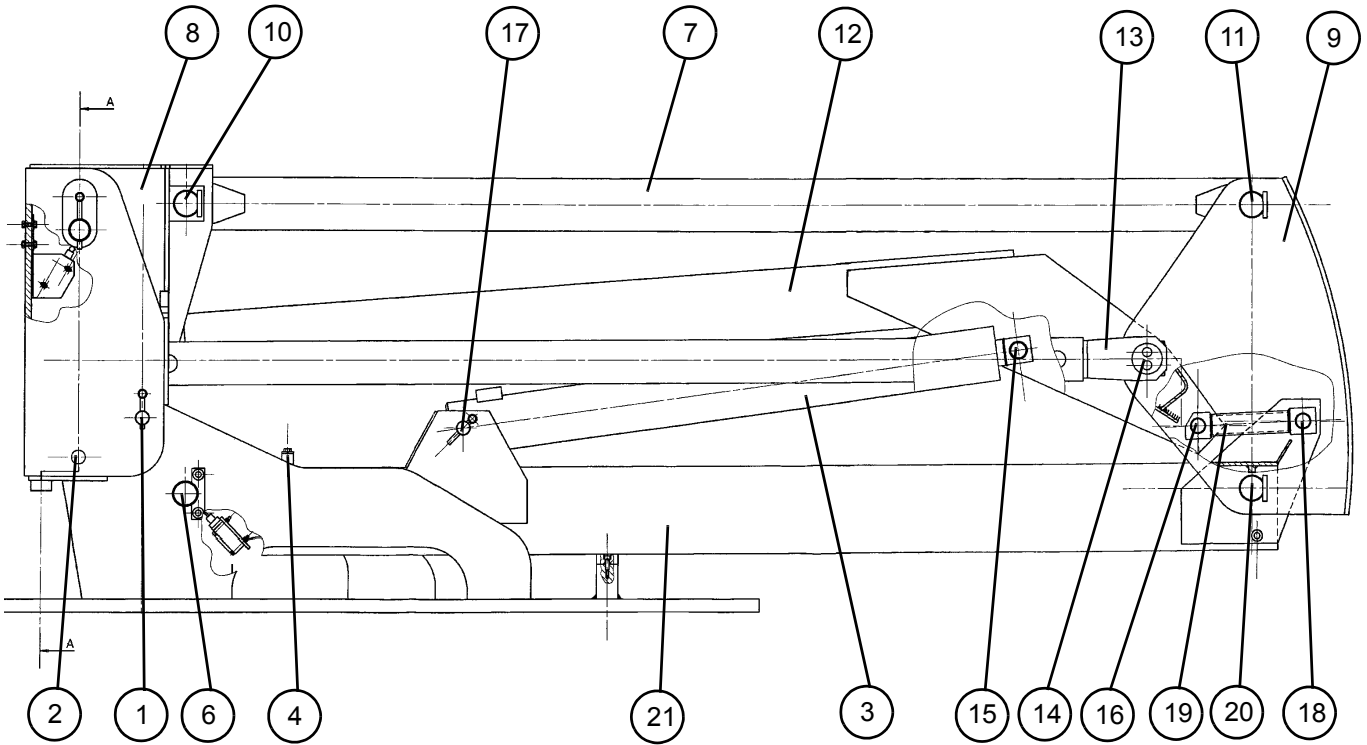

A - A

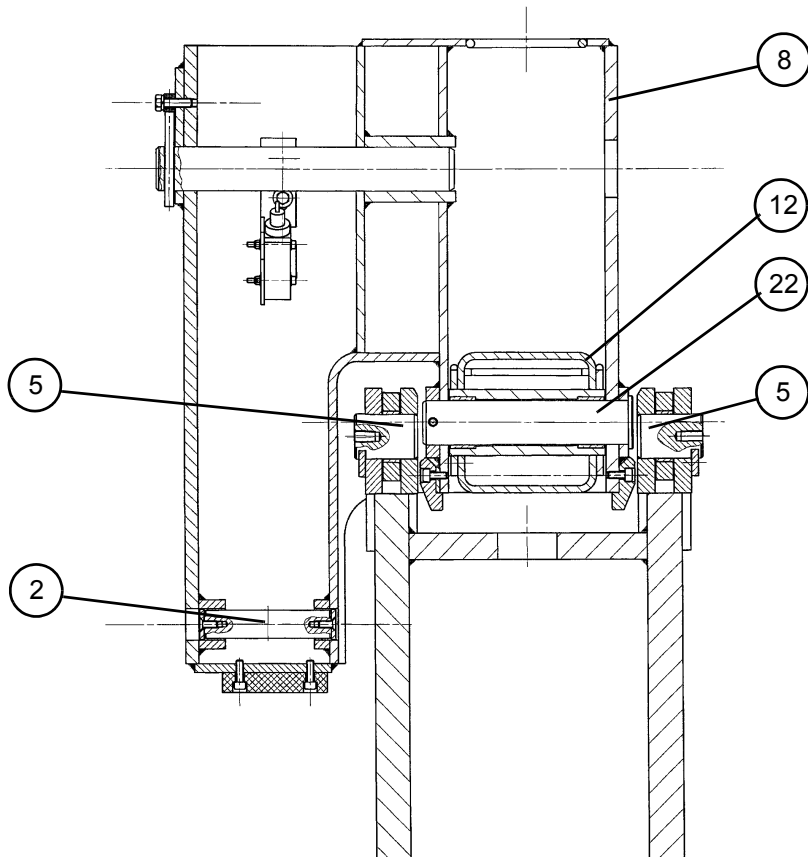

|            |                              |           |
|------------|------------------------------|-----------|
| Sheet C073 | CORRECTIVE MAINTENANCE SHEET | Folio 1/4 |
|            | ADJUSTING A PRESSURE LIMITER |           |

 **Caution!**  
Ensure that the oil is not too hot.

**NB:** Before any adjustment operation, operate the machine so that the oil in the tank is at a temperature of approximately 50°.

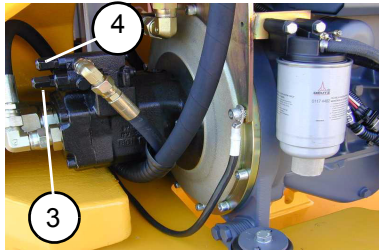

For HA15I - HA43E & HA12IP - HA33JE

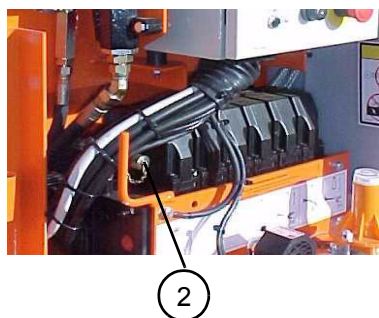
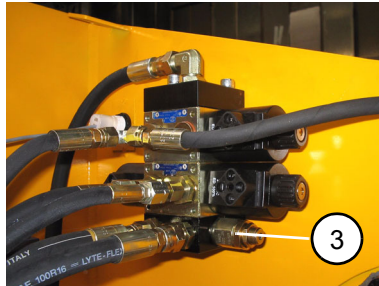

 **Caution!**  
Use a container to collect oil to prevent pollution of the environment.

### 1 - Adjusting the load sensing pressure (4)

- Put the machine in the maintenance configuration (see corresponding paragraph).
- Switch off electric power (see corresponding paragraph).
- Unscrew the cap of the minimess hydraulic pressure tapping (2) on the distribution block and connect a pressure gauge of at least 0/300 bars (0/4351 PSI).
- Switch electric power on again (see corresponding paragraph) and start the motor.
- Without activating a movement, measure pressure on the gauge.
- Adjust the hexagonal socket head screw on the pressure limiter (4) until the pressure indicated in the table below is shown on the pressure gauge.
- Put the machine in the maintenance configuration (see corresponding paragraph).
- Switch off electric power (see corresponding paragraph).
- Unscrew the pressure gauge and put the hydraulic pressure tapping cap back into place.
- Put the machine back in the operational configuration.
- Extend the machine several times to check operation.

### 2 - Adjusting the main pressure limiter (3)

- Put the machine in the maintenance configuration (see corresponding paragraph).
- Switch off electric power (see corresponding paragraph).
- Unscrew the cap of the minimess hydraulic pressure tapping (2) on the distribution block and connect a pressure gauge of at least 0/300 bars (0/4351 PSI).
- Switch electric power on again (see corresponding paragraph).
- Bring back the telescope cylinder fully (to its stop) to block the movement.
- Activate the bring back telescope and measure pressure on the gauge.
- Adjust the hexagonal socket head screw on the main pressure limiter (3) so that movements are disabled at the pressure indicated in the table below.
- Put the machine in the maintenance configuration (see corresponding paragraph).
- Switch off electric power (see corresponding paragraph).
- Unscrew the pressure gauge and put the hydraulic pressure tapping cap back into place.
- Put the machine back in the operational configuration.
- Make several boom lifting movements to check operation.

### 3 - Adjusting the telescope extension pressure limiter (1) (except HA15I-HA43E)

- Put the machine in the maintenance configuration (see corresponding paragraph).
- Switch off electric power (see corresponding paragraph).
- Unscrew the cap of the minimess hydraulic pressure tapping (2) on the distribution block and connect a pressure gauge of at least 0/300 bars (0/4351 PSI).
- Switch electric power on again (see corresponding paragraph).
- Extend the telescope cylinder fully (to its stop) to block the movement.
- Activate a telescoping movement and measure telescoping pressure on the gauge.
- Adjust the hexagonal socket head screw on the telescoping pressure limiter (1) so that movements are disabled at the pressure indicated in the table below.
- Put the machine in the maintenance configuration (see corresponding para-

|            |                              |           |
|------------|------------------------------|-----------|
| Sheet C073 | CORRECTIVE MAINTENANCE SHEET | Folio 2/4 |
|            | ADJUSTING A PRESSURE LIMITER |           |

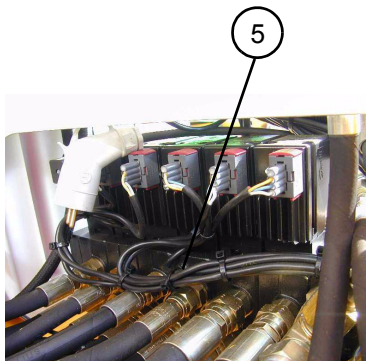

graph).

- Switch off electric power (see corresponding paragraph).
- Unscrew the pressure gauge and put the hydraulic pressure tapping cap back into place.
- Put the machine back in the operational configuration.
- Make several telescoping movements to check operation.

#### 4 - Checking the turntable rotation pressure limiter

**NB:** *Turntable rotation pressure is preset and may not be modified.*

- Put the machine in the maintenance configuration (see corresponding paragraph).
- Switch off electric power (see corresponding paragraph).
- Unscrew the cap of the minimess hydraulic pressure tapping (2) on the distribution block and connect a pressure gauge of at least 0/300 bars (0/4351 PSI).
- Switch electric power on again (see corresponding paragraph).
- Put the turntable rotation blocking pin in place to block movement.
- Activate turntable rotation and measure pressure on the gauge.

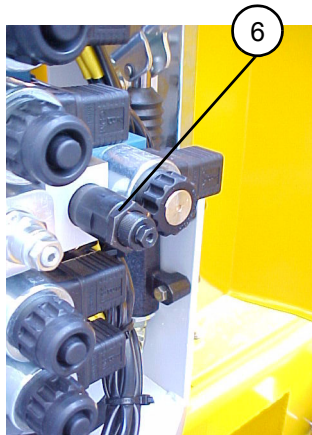

**NB:** *Check pressure in both rotation directions.*

- If the pressure measured is not conform to the value in the table, replace the pressure limiter concerned.
- Put the machine in the maintenance configuration (see corresponding paragraph).
- Switch off electric power (see corresponding paragraph).
- Unscrew the pressure gauge and put the hydraulic pressure tapping cap back into place.
- Put the machine back in the operational configuration.
- Make several turntable rotation movements to check operation.

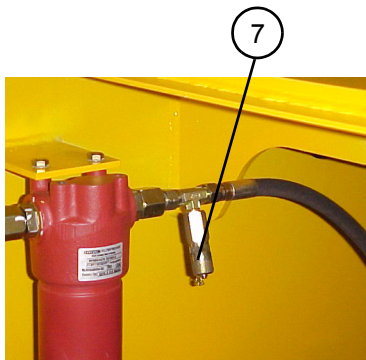

#### 5 - Adjusting the compensation pressure limiter (6)

- Put the machine in the maintenance configuration (see corresponding paragraph).
- Switch off electric power (see corresponding paragraph).
- Unscrew the cap of the minimess hydraulic pressure tapping (7) and connect a pressure gauge of at least 0/300 bars (0/4351PSI).
- Switch electric power on again (see corresponding paragraph).
- Extend the compensation cylinder fully (to its stop) to block the movement.
- Activate a compensayion movement and measure compensation pressure on the gauge.
- Adjust the hexagonal socket head screw on the compensation pressure limiter (6) so that movements are disabled at the pressure indicated in the table below.
- Put the machine in the maintenance configuration (see corresponding paragraph).
- Switch off electric power (see corresponding paragraph).
- Unscrew the pressure gauge and put the hydraulic pressure tapping cap back into place.
- Put the machine back in the operational configuration.
- Make several compensation movements to check operation.

|            |                              |           |
|------------|------------------------------|-----------|
| Sheet C073 | CORRECTIVE MAINTENANCE SHEET | Folio 3/4 |
|            | ADJUSTING A PRESSURE LIMITER |           |

**6 - Adjusting the pressure limiter (7) on the Oil Control block**

- Put the machine into the maintenance configuration (see relevant section).
- Put a manometer on the pressure tap at the bottom of the hydraulic block.
- Open the chassis cover to access the steering hydraulic block.
- Mark the pressure limiter on the P/T supply section.
- Unscrew the counter-nut on the limiter and use a hexagonal wrench to tighten to increase pressure or slacken to reduce pressure. Tighten the counter-nut.
- Pressure should be set at a value of 210 bar +/- 5 bar (3046 PSI +/- 72.5 PSI) [activate a telescope in movement (force to the stop) to make this pressure adjustment]

**6 - Pressure table (in psi)**

|  | Load sensing (stand by) | Main | Steering | Brake release | Right and left rotation | Lifting | Lowering | Boom lifting |
|--|-------------------------|------|----------|---------------|-------------------------|---------|----------|--------------|
| HA16-18PX<br>HA46/51JRT                  | 435                     | 3481 | 3481     | 3481          | 1450                    | 3481    | 3481     | 3481         |
| HA16-18PX NG<br>HA46/51JRT<br>New Design | 435                     | 3481 | 3481     | 3481          | 1450                    | 3481    | 3481     | 3481         |
| HA12IP<br>HA33JE                         | -----                   | 3045 | 3045     | 3045          | 1160                    | 3045    | 3045     | 3045         |
| HA15I<br>HA43E                           | -----                   | 3191 | 3191     | 3191          | 1160                    | 3191    | 3191     | 3191         |

|   | Boom lowering | Telescope out | Telescope in | Travel | Compensation | Jib lifting | Jib lowering | Standby unit |
|---|---------------|---------------|--------------|--------|--------------|-------------|--------------|--------------|
| HA16-18PX<br>HA46/51JRT                     | 3481          | 1595          | 3481         | 3481   | 3481         | 3481        | 3481         | manual       |
| HA16-18PX<br>NG<br>HA46/51JRT<br>New Design | 3481          | 1595          | 3481         | 3481   | 3481         | 3481        | 3481         | 3045         |
| HA12IP<br>HA33JE                            | 3045          | 3045          | 3045         | -----  | 2103         | 3045        | 3045         | manual       |
| HA15I<br>HA43E                              | 3191          | 3191          | 3191         | -----  | 3191         | 3191        | 3191         | manual       |

|            |                              |           |
|------------|------------------------------|-----------|
| Sheet C073 | CORRECTIVE MAINTENANCE SHEET | Folio 4/4 |
|            | ADJUSTING A PRESSURE LIMITER |           |

|            |                                    |           |
|------------|------------------------------------|-----------|
| Sheet C075 | CORRECTIVE MAINTENANCE SHEET       | Folio 1/2 |
|            | CHANGING THE BOOM LIFTING CYLINDER |           |

---

 **Caution!**  
**Ensure that the oil is not too hot.**

---

### 1 - Preliminary operations

- Position the elevating platform on a firm, horizontal surface.
- Put the turntable rotation blocking pin into place.
- Lift the boom to enable access to the arm lifting cylinder fixtures (1).
- Retract the telescope, lower the arm and put the jib in the low position.
- Switch off electric power (see corresponding paragraph).
- Put the boom into slings to take the weight of the boom while the cylinder is removed.

### 2 - Removing the boom lifting cylinder

- Put the boom lifting cylinder into slings.
- Mark and disconnect the two hydraulic hoses on the boom lifting cylinder.

**NB:** *Unscrew the hoses slowly to release residual hydraulic pressure.*

- Fit caps to the hoses.
- Remove the male clevis blocking the pin (3) of the boom lifting cylinder, on the cylinder body side, by removing its fixing screw and washer, then remove the pin (3).
- Remove the male clevis blocking the pin (2) of the boom lifting cylinder, on the cylinder rod side, by removing its fixing screw and washer, then remove the pin (2).
- Remove the boom lifting cylinder.

### 3 - Installing the boom lifting cylinder

**NB:** *Lubricate all bores before re-installing the pins. Only use lubricants recommended by the manufacturer.*

- Put the boom lifting cylinder into place and fix the rod side to the boom support with the articulation pin.
- Install the male clevis to block the cylinder pin and fix with its fixing screw equipped with a new grower washer.
- Fix the boom lifting cylinder on the body side of the cylinder using the pin.
- Install the male clevis to block the pin and fix with its fixing screw equipped with a new grower washer.
- Reconnect the 2 hydraulic hoses of the boom lifting cylinder.

### 4 - Additional operations

- Lower the boom.
  - Remove the sling from the boom.
  - Put the machine back into the operational configuration.
  - Make several boom lifting movements to check operation and purge the hydraulic circuit.
  - Check the level of the hydraulic circuit.
-

|            |                                    |           |
|------------|------------------------------------|-----------|
| Sheet C075 | CORRECTIVE MAINTENANCE SHEET       | Folio 2/2 |
|            | CHANGING THE BOOM LIFTING CYLINDER |           |

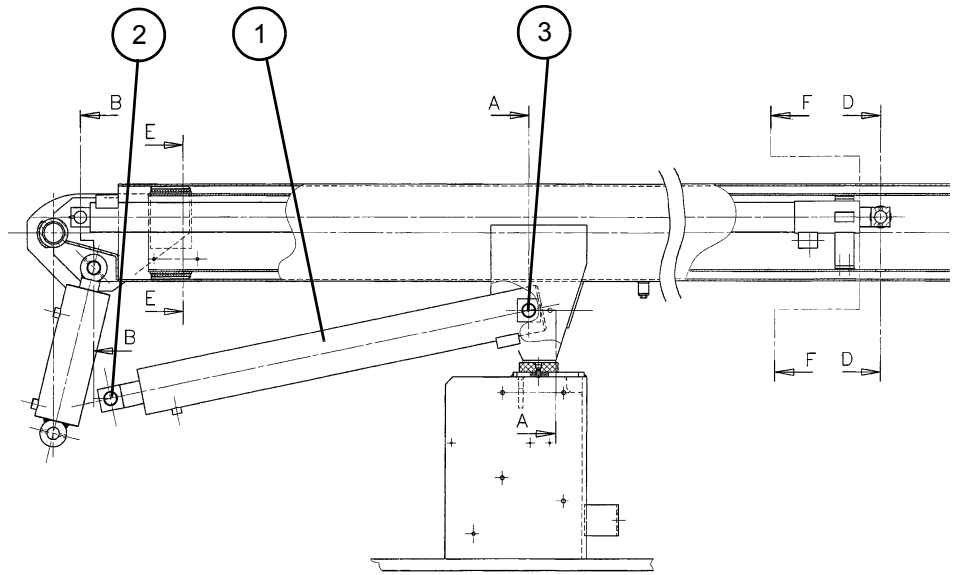

|            |                                   |           |
|------------|-----------------------------------|-----------|
| Sheet C078 | CORRECTIVE MAINTENANCE SHEET      | Folio 1/2 |
|            | CHANGING THE ARM LIFTING CYLINDER |           |



**Caution!**

**Ensure that the oil is not too hot.**

### 1 - Preliminary operations

- Position the elevator platform on a firm, horizontal surface.
- Put the turntable rotation blocking pin into place.
- Lift the arm to enable access to the arm lifting cylinder fixtures (1).
- Retract the telescope, lower the boom as far as possible and put the jib in the low position.
- Switch off electric power (see corresponding paragraph).
- Wedge the arm to take the weight of the boom while the arm lifting cylinder is removed.

### 2 - Removing the arm lifting cylinder

- Put the arm lifting cylinder in slings.
- Mark and disconnect the 2 hydraulic hoses of the arm lifting cylinder.

**NB:** *Unscrew the hoses slowly to release residual hydraulic pressure.*

- Fit caps to the hoses.
- Remove the male clevis blocking the pin (3) of the arm lifting cylinder on the rod side by removing its fixing screw and washer, then remove the pin (3).
- Remove the male clevis blocking the pin (2) of the arm lifting cylinder on the cylinder body side by removing its fixing screw and washer, then remove the pin (2).
- Remove the arm lifting cylinder.

### 3 - Installing the arm lifting cylinder

**NB:** *Lubricate all bores before re-installing the pins. Only use lubricants recommended by the manufacturer.*

- Put the arm lifting cylinder into place and fix the cylinder body side to the bottom arm using the articulation pin.
- Install the male clevis blocking the cylinder pin and fix using its fixing screw equipped with a new grower washer.
- 
- Fix the arm lifting cylinder rod to the top arm using the pin.
- Install the male clevis blocking the pin and fix using its fixing screw equipped with a new grower washer.
- Reconnect the two hydraulic hoses of the arm lifting cylinder.

### 4 - Additional operations

- Put the machine back into the operational configuration.
- Remove the wedges from the arm.
- Lower the arm.
- Make several arm lifting movements to test its operation and purge the hydraulic circuit.
- Check the level of the hydraulic circuit.

|            |                                   |           |
|------------|-----------------------------------|-----------|
| Sheet C078 | CORRECTIVE MAINTENANCE SHEET      | Folio 2/2 |
|            | CHANGING THE ARM LIFTING CYLINDER |           |

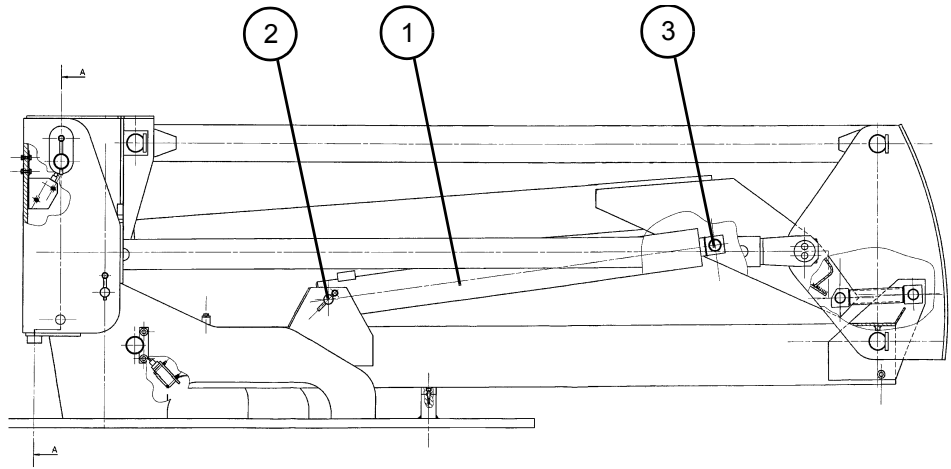

|            |  |           |
|------------|--|-----------|
| Sheet C082 | CORRECTIVE MAINTENANCE SHEET                             | Folio 1/1 |
|            | CHANGING A BALANCING VALVE FOR THE COMPENSATION FUNCTION |           |

 **Caution!**  
*Ensure that the oil is not too hot.*

 **Caution!**  
*Use a container to collect oil to prevent pollution of the environment.*

 **Caution!**  
*Balancing valves are safety elements. They are calibrated in the plant and must not be re-adjusted.*

**1 - Preliminary operations**

- Put the machine in the maintenance configuration (see corresponding paragraph).
- Switch off electric power (see corresponding paragraph).

**2 - Removing a balancing valve**

- Remove the balancing valve (1) by unscrewing it.

**3 - Installing a balancing valve**

- Screw a new balancing valve, whose characteristics correspond to the machine in question, into the hydraulic block. Tighten to a torque of 45 to 50 Nm (33 to 36.8 lb.ft).
- Put the machine back into the operational configuration.
- Make several movements using the replaced balancing valve to purge the circuit.
- Check that the corresponding movement is made correctly.

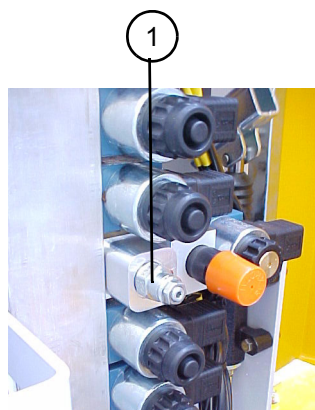
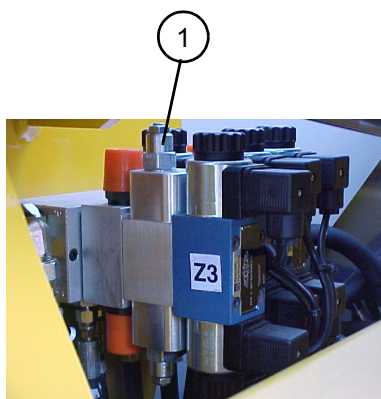

HA12IP - HA33JE



|            |                                 |           |
|------------|---------------------------------|-----------|
| Sheet C139 | CORRECTIVE MAINTENANCE SHEET    | Sheet 1/2 |
|            | CHARGING THE TRACTION BATTERIES |           |

 **Caution!**  
Do not use the machine during the charging process.

 **Caution!**  
Use the machine's on-board charger. Its charge output is suited to the machine.

 **Caution!**  
Safety precautions are required for battery servicing operations (wear gloves and protective goggles).

**1 - Preliminary operations**

- Ensure that the mains supply is suitable for the charger's consumption and voltage.
- Fill to the minimum electrolyte level if an element's level is below this minimum.
- Work in a clean, ventilated area, away from naked flames.

**2 - Charging the batteries**

**NB:** Charging starts automatically as soon as the mains supply is connected. For information: charging time for a battery discharged by 80% is approximately 15 hours.

- Connect the plug (2) to the mains (110V for USA).
- Check the charge state on the light (3) on the bottom control panel.
  - Red zone: machine charging
  - Yellow zone: 80% of charging complete
  - Green zone: batteries charged



1

Star 8 / Star 22J



2

Star 8 / Star 22J



3

|            |                                 |           |
|------------|---------------------------------|-----------|
| Sheet C139 | CORRECTIVE MAINTENANCE SHEET    | Sheet 2/2 |
|            | CHARGING THE TRACTION BATTERIES |           |

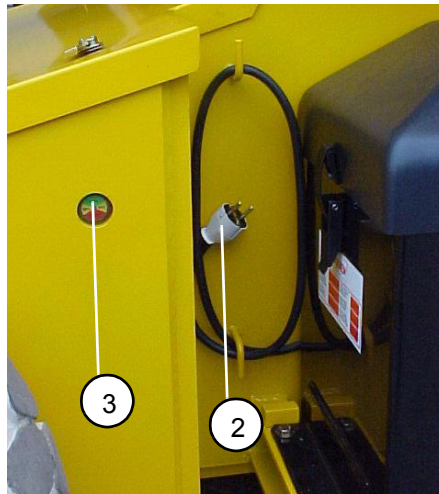

HA12IP - HA33JE

**3 - During charging**

- Do not remove or close the element caps.
- Ensure that element temperature does not exceed 45°C (be careful in summer or in rooms with high ambient temperature).

**4 - After charging**

- Top up the electrolyte level if necessary.

**4 - Additional operations**

- Put the machine back into the operational configuration.

|            |                              |           |
|------------|------------------------------|-----------|
| Sheet C204 | CORRECTIVE MAINTENANCE SHEET | Sheet 1/1 |
|            | REPLACING THE HYDRAULIC PUMP |           |

 **Caution!**  
*Ensure that the oil is not too hot.*

 **Caution!**  
*Use a container to collect the oil.*

 **Caution!**  
*It is essential to put the component into slings before dismantling and reassembling it.*

**1 - Preliminary operations**

- Put the machine into maintenance configuration (see relevant section).
- Switch off the electric power supply (see relevant section).

**2 - Removing the hydraulic pump**

- Remove the motorpump unit (see relevant sheet).
- Remove the screws fixing the pumps (2) to the motor and remove the pumps (1).

**3 - Reinstalling the hydraulic pump**

- Put new pumps, equipped with new seals, into place on the electric motor and secure with fixing screws.
- Put back the motorpump unit (see relevant sheet).
- Put the machine back into the operational configuration.
- Make several lifting cycles to purge the hydraulic circuit.
- Check the level of the hydraulic oil tank.



① ②  
 HA12IP - HA33JE



①

STAR 8 / STAR 22J

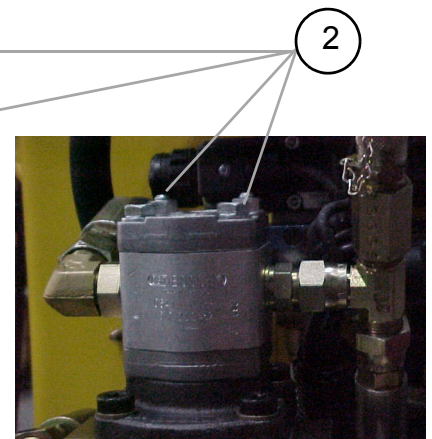

②

|  |                              |  |
|--|------------------------------|--|
|  | CORRECTIVE MAINTENANCE SHEET |  |
|  |                              |  |

|            |   |          |
|------------|---|----------|
| SHEET C208 | CORRECTIVE MAINTENANCE SHEET                  | Sheet1/1 |
|            | REPLACING THE TURNTABLE EMERGENCY STOP BUTTON |          |

**Caution!**  
*Do not use the machine during maintenance operations.*

**1 - Preliminary operations**

- Put the machine into the maintenance configuration (see relevant section).
- Switch off the electric power supply (see relevant section).
- Disconnect the “-” then “+” terminals of the batteries to isolate the electric circuit.

**2 - Removing the emergency stop button**

- Mark and disconnect the electric connections (1) of the emergency stop button.
- Remove the head of the emergency stop button (2) by unscrewing it, having blocked its pin by inserting a rod into the hole (3) provided.
- Remove the emergency stop button by unscrewing its two fixing screws (4).

**3 - Reinstalling the emergency stop button**

- Put a new emergency stop button into place.
- Reconnect the electric connections according to the marks made during dismantling.

**4 - Test**

- Reconnect the “+” then “-” terminals of the batteries.
- Put the machine back into the operational configuration.
- Check that the emergency stop button works properly.



STAR 8 / STAR 22 J

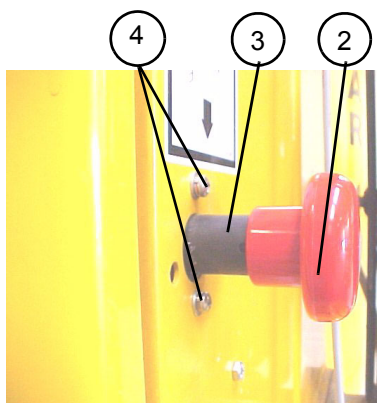

STAR 8 / STAR 22 J

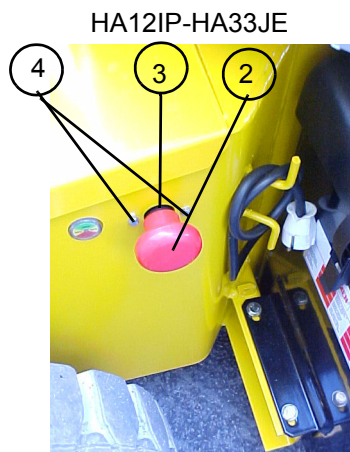

HA12IP-HA33JE

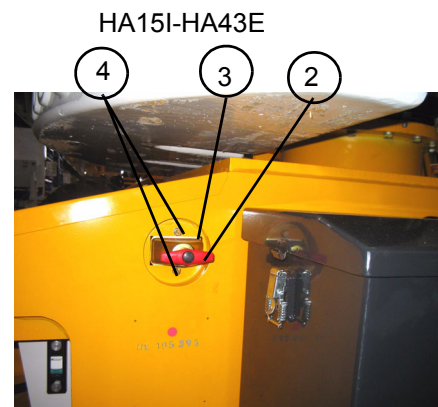

HA15I-HA43E

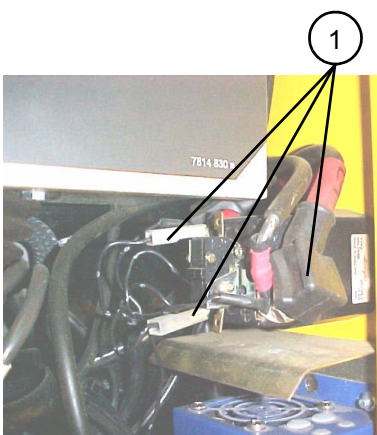

1

|  |                              |  |
|--|------------------------------|--|
|  | CORRECTIVE MAINTENANCE SHEET |  |
|  |                              |  |

|            |                              |           |
|------------|------------------------------|-----------|
| Sheet C220 | CORRECTIVE MAINTENANCE SHEET | Folio 1/1 |
|            | REPLACING THE COUNTERWEIGHTS |           |

**1 - Preliminary operations**

**PUT THE BOOM INTO SLINGS TO SECURE THE ARM, AND AVOID TIPPING OVER WHEN THE COUNTERWEIGHT IS REMOVED.**

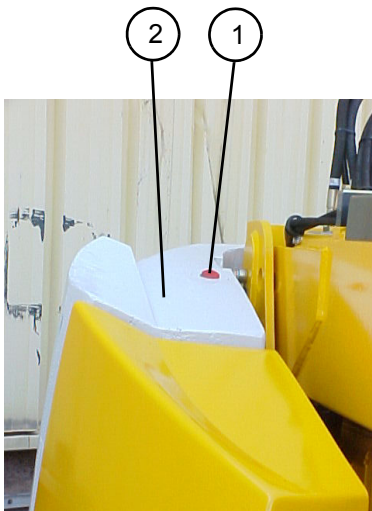

- Screw the lifting rings (1) onto the counterweight (2) and attach to a hoist.
- Secure a lifting crane to the hoist and apply tension to the lifting crane.
- Switch off the electric power supply (see relevant section).

**2 - Removing the counterweight**

- Remove the fixing screws and washer (3).
- Remove the counterweight (2)

**4 - Reinstalling the counterweight**

- Put the counterweight (2) into place against the stops on the turntable.
- Put back the fixing screws and washers (3).

**6 - Additional operations**

- Check that the counterweight is properly secured to the machine.
- Remove the counterweight lifting rings.
- Remove the slings from the boom.
- Put the machine back into the operational configuration.

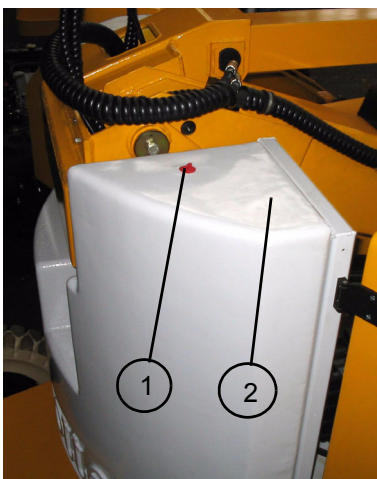

HA15I -HA43I

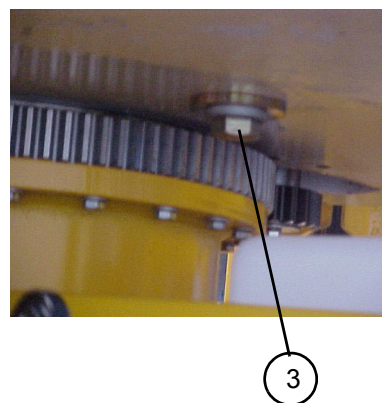
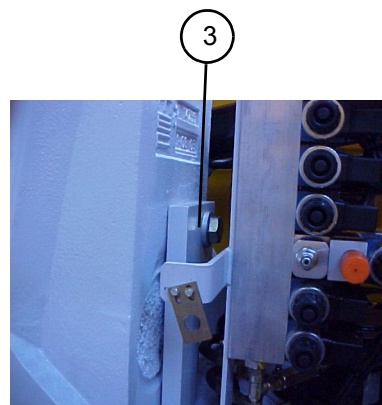

**Caution!**

**Make sure that the lifting means are in good condition and of sufficient capacity.**



**Caution!**

**The component must be put into slings before dismantling and reassembling it.**



**Caution!**

**Do not use the machine during maintenance operations.**

|            |                              |  |
|------------|------------------------------|--|
| Sheet C220 | CORRECTIVE MAINTENANCE SHEET |  |
|            | REPLACING THE COUNTERWEIGHTS |  |

|            |                               |           |
|------------|-------------------------------|-----------|
| SHEET C221 | CORRECTIVE MAINTENANCE SHEET  | Folio 1/1 |
|            | REMOVING-REPLACING THE COVERS |           |

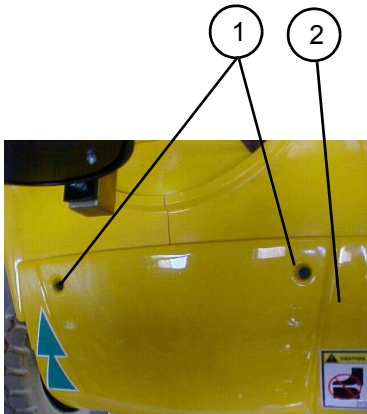

**1 - Preliminary operations**

- Put the machine into the maintenance configuration (see relevant section).
- Switch off the electric power (see relevant section).

**2 - Removing the motor cover (2)**

- Unscrew the fixing screws (1).
- Remove the cover (2)

**3 - Reinstalling the motor cover (2)**

- Put a new cover into place (2).
- Tighten the fixing screws (1).

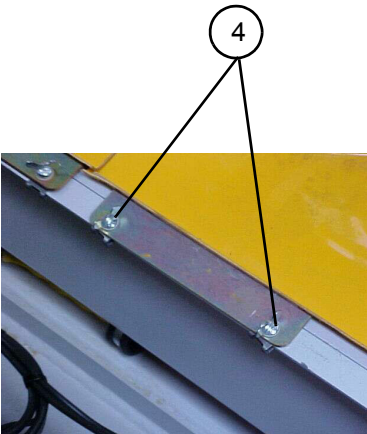

**4 - Removing a side cover (3)**

- Remove the motor cover first (2)
- Manually unscrew the fins (4).
- Unscrew the screws (5).
- Remove the cover (3).

**5 - Reinstalling a side cover (3)**

- Put a new side cover (3) into place.
- Tighten the screws (5) and fins (4).
- Reinstall the motor cover (2).

**6 - Removing a pivoting turntable cover (6)**

- Open the cover (6) and put into slings
- Remove the pins (7), take the cover off its hinges and remove (except HA15I - HA43E).
- Unscrew the hinge (8) (HA15I - HA43E)

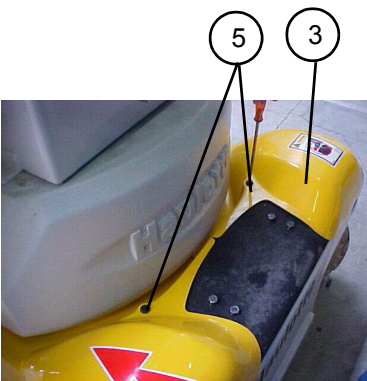

**7 - Reinstalling a pivoting turntable cover (6)**

- Put a new cover (6) into place.
- Remove the slings.

**8 - Additional operations**

- Check that the cover is properly secured to the machine.
- Put the machine back into the operational configuration.

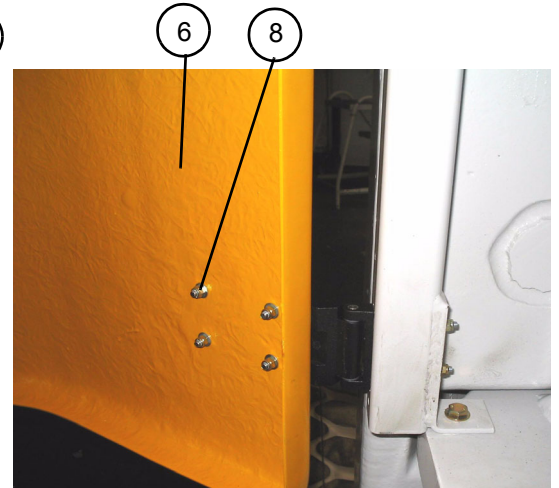

|  |                              |  |
|--|------------------------------|--|
|  | CORRECTIVE MAINTENANCE SHEET |  |
|  |                              |  |

|            |                              |           |
|------------|------------------------------|-----------|
| SHEET C222 | CORRECTIVE MAINTENANCE SHEET | Folio 1/1 |
|            | REPLACING THE MANIPULATOR    |           |

---

**Caution!**  
**Do not use the machine during maintenance operations.**

---

**1 - Preliminary operations**

- Put the machine into the maintenance configuration (see § 6.2, page 25).
- Switch off the electric power (see § 6.3, page 26).
- Consult sheet C219 for instructions on removing the panel closing plate (1)

**2 - Removing the manipulator (2)**

- Mark and disconnect the manipulator's electric connections.
- Remove the manipulator by taking out its fixing screws.

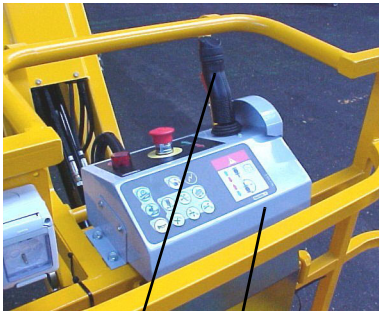

②    ①

**3 - Reinstalling the manipulator**

- Fix a manipulator, with new seals, on the platform control panel.
- Reconnect the electric connections according to the marks made during dismantling.
- Put the machine back into the operational configuration.
- Make a few lifting and lowering movements from the platform controls to make sure that the manipulator works properly.



②    ①

|  |                              |  |
|--|------------------------------|--|
|  | CORRECTIVE MAINTENANCE SHEET |  |
|  |                              |  |

|            |                                 |           |
|------------|---------------------------------|-----------|
| SHEET C223 | CORRECTIVE MAINTENANCE SHEET    | Folio 1/2 |
|            | REPLACING THE STEERING CYLINDER |           |

**Caution!**  
**Make sure that the oil is not too hot.**

**1 - Preliminary operations**

- Put the machine into the low configuration.
- Switch off the electric power (see § 6.3, page 26).
- Raise the machine using a jack or hoist.

**2 - Removing the steering cylinder**

- Mark and disconnect the two hoses (1) of the steering cylinder (2).



**NB:** *Unscrew the hoses slowly to eliminate residual hydraulic pressure.*

- Put caps on the hoses.
- Put the cylinder into slings.
- Remove the 4 screws (3) and elastic pin (5) fixing the cylinder to the chassis.
- Remove the 2 pins (4) fixing the cylinder to the steering rods.
- Remove the steering cylinder.



**3 - Reinstalling the steering cylinder**

- Put a new steering cylinder into place.
- Put the 4 screws (3) and elastic pin back into place.
- Put the 2 pins (4) back into place.
- Reconnect the hydraulic hoses according to the marks made during dismantling.
- Put the machine back into the operational configuration.
- Make several steering movements to purge the hydraulic circuit.
- Check the level of the hydraulic oil tank.

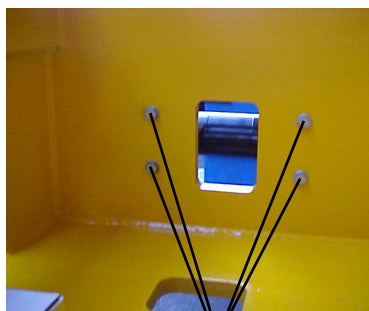

|            |                                 |           |
|------------|---------------------------------|-----------|
| SHEET C223 | CORRECTIVE MAINTENANCE SHEET    | Folio 2/2 |
|            | REPLACING THE STEERING CYLINDER |           |

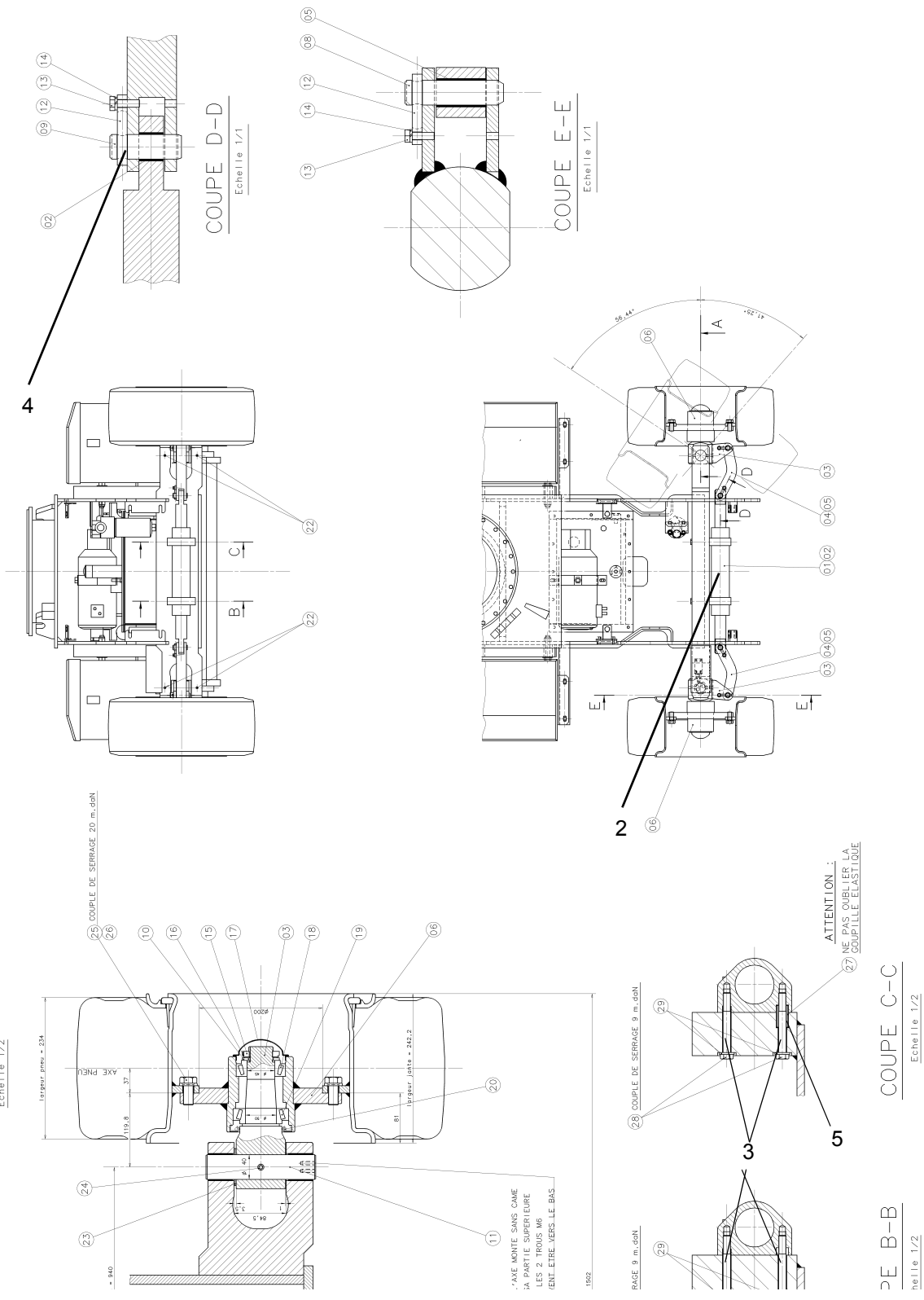

|            |                              |           |
|------------|------------------------------|-----------|
| Sheet C224 | CORRECTIVE MAINTENANCE SHEET | Folio 1/2 |
|            | REPLACING A STEERING PIVOT   |           |

**Caution!**

**Make sure that the oil is not too hot.**

**Caution!**

**Collect old oil to avoid pollution of the environment.**

**Caution!**

**The component must be put into slings before dismantling and reassembling it.**

**1 - Preliminary operations**

- Put the machine into the maintenance configuration (see relevant section).
- Switch off the electric power (see relevant section).
- Remove the wheel corresponding to the element to be replaced (see relevant sheet).
- Remove the motor and reducer corresponding to the pivot to be replaced (see corresponding sheet).

**2 - Removing a pivot**

- Place a wedge under the steering pivot (3).
- Remove the fixing screw (13).
- Remove the clevis pin (09).
- Put the pivot assembly (06) into slings.
- Take out the mecanindus pin (24), and remove the pin (11)
- Take out the pivot assembly.

**3 - Reinstalling a pivot**

- Ensure that the rings are in place on the new pivot.
- Fit new washers and pins.
- Perform the dismantling operations in reverse order to reassemble.

**NB:** *When reinstalling pins, take any precautions necessary to avoid damaging pins, rings and bores.*

**4 - Additional operations**

- Put back the motor and reducer (see relevant sheet).
- Put back the wheel (see relevant sheet).
- Put the machine back into the operational configuration.
- Make several travel movements to purge the hydraulic circuit.
- Check the level of oil in the wheel reducer (see relevant sheet).
- Check the level of the hydraulic oil tank.
- Grease the pins with greasers.

|            |                              |           |
|------------|------------------------------|-----------|
| Sheet C224 | CORRECTIVE MAINTENANCE SHEET | Folio 2/2 |
|            | REPLACING A STEERING PIVOT   |           |

COUPE A-A  
Echelle 1/2

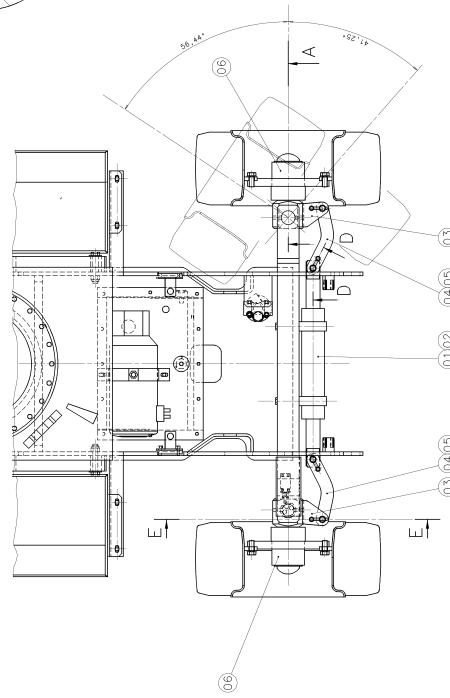
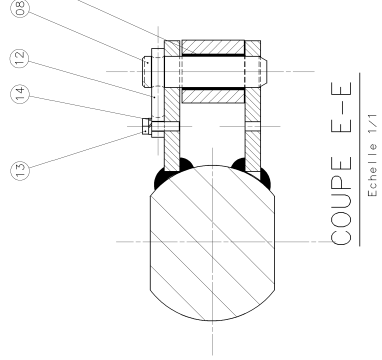
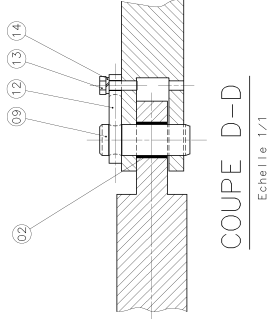
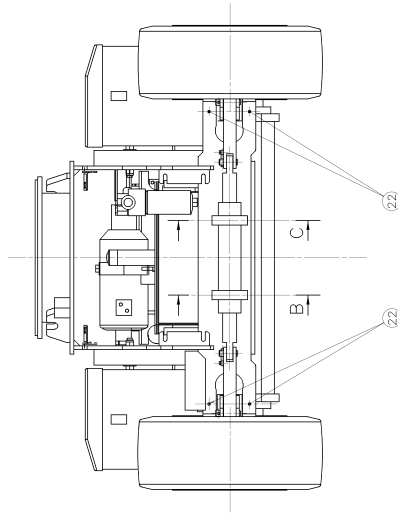
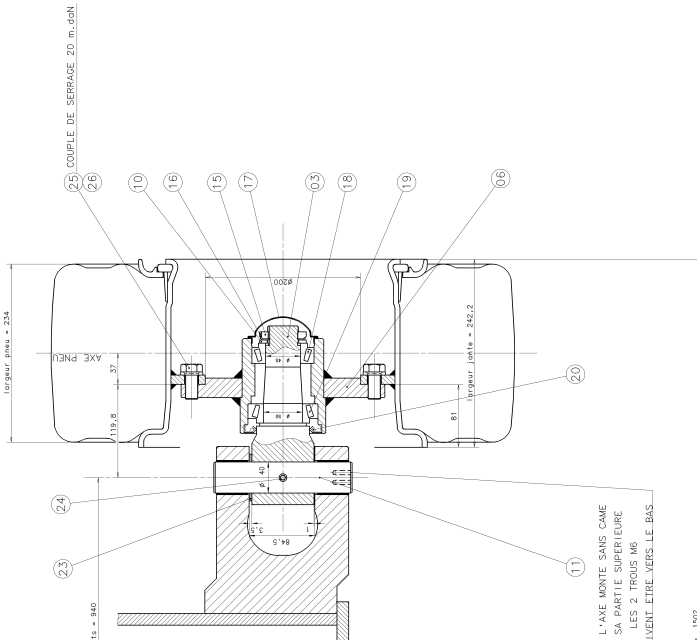

28 COUPLE DE SERRAGE 9 m.daN

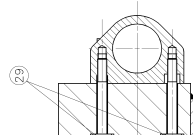

29 COUPLE DE SERRAGE 9 m.daN

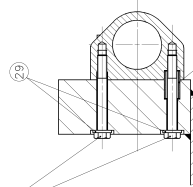

ATTENTION :  
NE PAS OUBLIER LA SOUFFLETTE ELASTIQUE

PE B-B  
Echelle 1/2

COUPE C-C  
Echelle 1/2

|            |                              |           |
|------------|------------------------------|-----------|
| Sheet C226 | CORRECTIVE MAINTENANCE SHEET | Folio 1/2 |
|            | REPLACING A TRAVEL REDUCER   |           |

 **Caution!**  
*Ensure that the oil is not too hot.*

 **Caution!**  
*Collect old oil to prevent pollution of the environment.*

 **Caution!**  
*The component must be put into slings before dismantling and reassembling it.*

 **Caution!**  
*Ensure that the lifting means are in good condition and of sufficient capacity.*

**1 - Preliminary operations**

- Put the machine into the maintenance configuration (see relevant section).
- Switch off the electric power (see relevant section).
- Raise the chassis with a jack or hoist.

**2 - Removing a travel reducer**

- Put the electric motor (1) into slings.
- Disconnect the electric wiring harnesses (2) (after marking them) from the travel motor (1).
- Disconnect the electric motor (1) from the travel reducer using the screws(3).
- Replace the defective travel reducer.
- Mark and disconnect the hoses (4) of the reducing gear (**For HA15I-HA43E**).

**3 - Reinstalling a travel reducer**

- Perform the dismantling operations in reverse order to reassemble.
- Reconnect the electric wiring harnesses according to the marks made during dismantling.
- Use new washers.
- Reconnect the hydraulic hoses to the reducing gear hose equipped with a new seal, according to the marks made when dismantling (**For HA15I-HA43E**).

**4 - Additional operations**

- Put the machine back into the operational configuration.

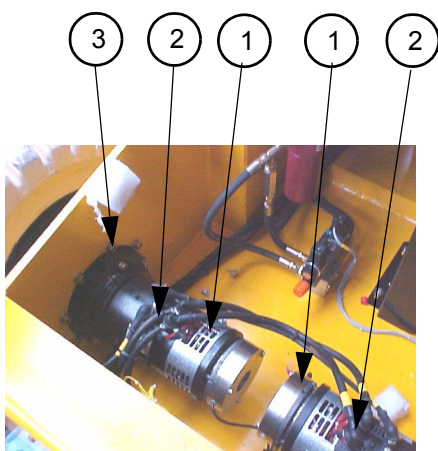

Photo 1

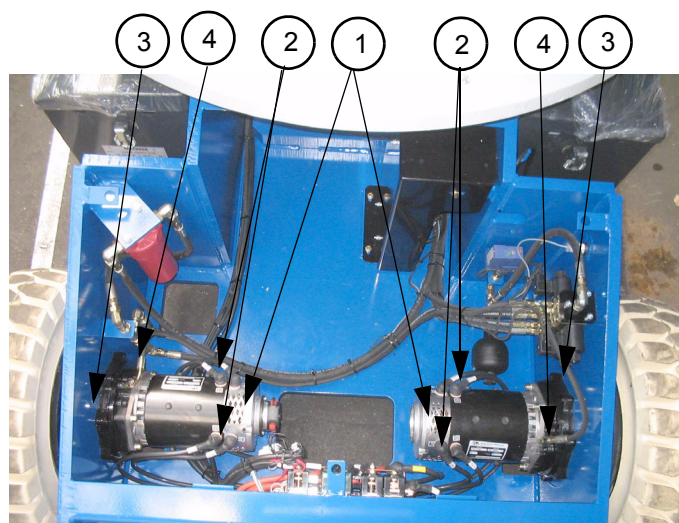

Photo 2 (HA15I-HA43E)

|            |                              |           |
|------------|------------------------------|-----------|
| Sheet C226 | CORRECTIVE MAINTENANCE SHEET | Folio 2/2 |
|            | REPLACING A TRAVEL REDUCER   |           |

|            |                                    |           |
|------------|------------------------------------|-----------|
| Sheet C227 | CORRECTIVE MAINTENANCE SHEET       | Folio 1/1 |
|            | REMOVING - REPLACING THE BATTERIES |           |

---

 **Caution!**  
**Battery servicing operations must be carried out with appropriate safety precautions (wear protective gloves and glasses).**

---

**1 - Preliminary operations**

- Put the machine into the maintenance configuration (see relevant section).
- Switch off electric power (see relevant section).
- Disconnect the “-” and then “+” terminals of the batteries.

**2 - Removing the battery (1)**

- Put the battery support into slings using the lifting rings (2).
- Unscrew both sets of 2 screws (3)
- Using a gantry crane, remove the battery.

**3 - Reinstalling the batteries**

- Perform the dismantling operations in reverse order to reassemble.

**4 - Additional operations**

- Reconnect the “+” then “-” terminals of the batteries.
- Put the machine back into the operational configuration.

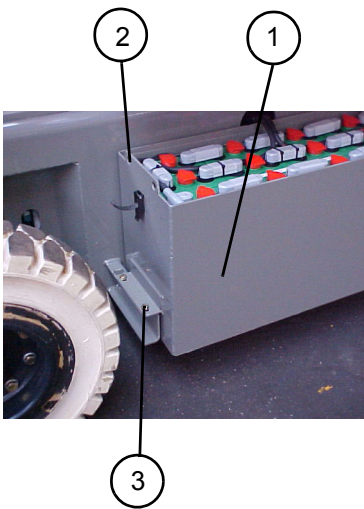

|  |                              |  |
|--|------------------------------|--|
|  | CORRECTIVE MAINTENANCE SHEET |  |
|  |                              |  |

|            |                                      |           |
|------------|--------------------------------------|-----------|
| Sheet C228 | CORRECTIVE MAINTENANCE SHEET         | Folio 1/2 |
|            | CHANGING THE BASKET ROTATION GEARING |           |

### 1 - Preliminary operations

- Put the machine in the maintenance configuration (see corresponding paragraph).
- Switch off electric power (see corresponding paragraph).
- Remove the basket (see corresponding sheet).

### 2 - Removing the gearing

- Remove the fixing screw (60).
- Remove the pin (9) and recover struts (19), the key (29), the endless screw (46) and adjustment washers (102,103,105,106), if any.
- Remove the fixing screw (21). Retain the toothed washer (63).
- Remove the cap (5), then the platform link part (3) and Nylatron washer (23).
- Remove the tangent wheel (46) and the key (28),



#### **Caution!**

***It is essential to put the component into slings before dismantling/re-assembling it.***

### 3 - Installing the gearing

- Replace rings, pads and keys if necessary.
- Put into place on the articulation pin (8), the key (28), tangent wheel (46).
- Put into place the Nylatron washer (23), platform link part (3) and cap (5).
- Fix the assembly using the screw (21) equipped with a new toothed washer(63).
- Install the endless screw (46) with the pin (9) and recover struts (19), the key (29) and adjustment washers (102,103,105,106) if necessary.
- Tighten screws of pressure (60).
- Install the basket (see corresponding sheet).
- Lubricate the gearing.

**NB:** *Only use lubricants recommended by the manufacturer.*

- Put the machine back into the operational configuration.

|            |                                      |           |
|------------|--------------------------------------|-----------|
| Sheet C228 | CORRECTIVE MAINTENANCE SHEET         | Folio 2/2 |
|            | CHANGING THE BASKET ROTATION GEARING |           |

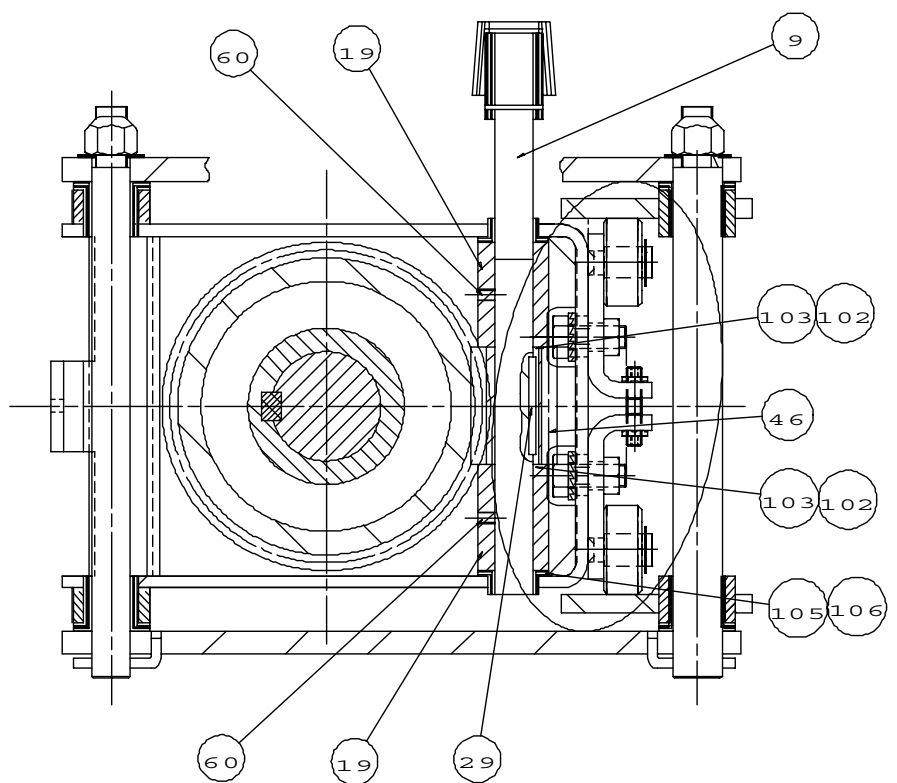
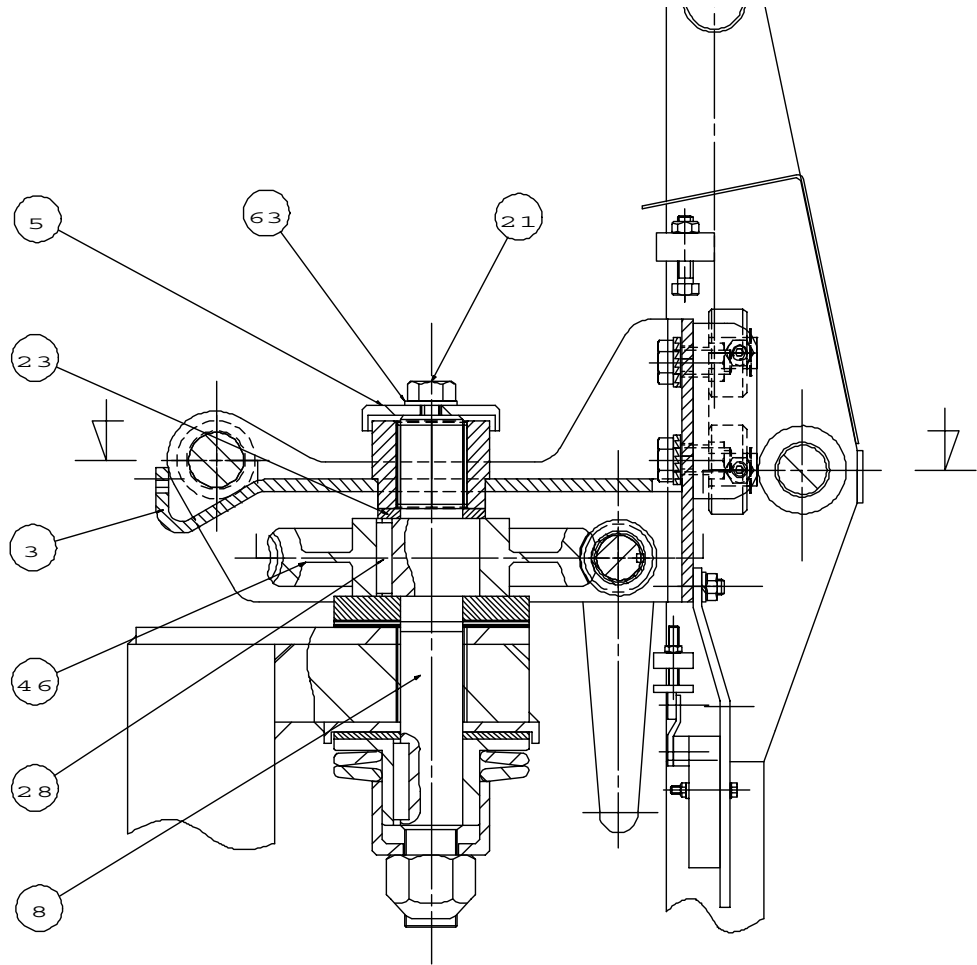

|            |                              |           |
|------------|------------------------------|-----------|
| Sheet C229 | CORRECTIVE MAINTENANCE SHEET | Folio 1/6 |
|            | REPLACING THE SLEW RING      |           |



**Caution!**

**Make sure that the oil is not too hot.**



**Caution!**

**Make sure the lifting means are in good condition and of sufficient capacity.**



**Caution!**

**Collect old oil to prevent pollution of the environment.**



**Caution!**

**The component must be put into slings before dismantling and reassembling it.**

**1 - Preliminary operations**

- Turn the turntable to the locking position.
- Put the machine in the maintenance configuration (see relevant section).
- Switch off electric power (see relevant section).
- Disconnect the battery (see relevant sheet).
- Remove the chassis covers (see relevant sheet).
- Remove the boom assembly (see relevant sheet).
- Remove the counterweight (see relevant sheet).
- Mark and disconnect the hoses (rep.1 Photo 1) (situated on the turret) of the block movement and put caps on the connectors.

**NB:** *Unscrew the hoses slowly to release residual hydraulic pressure.*

Photo 1

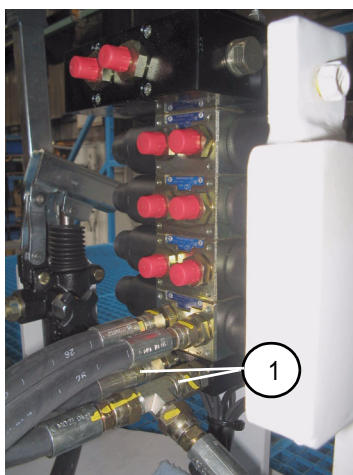

|            |                              |           |
|------------|------------------------------|-----------|
| Sheet C229 | CORRECTIVE MAINTENANCE SHEET | Folio 2/6 |
|            | REPLACING THE SLEW RING      |           |

Photo 2

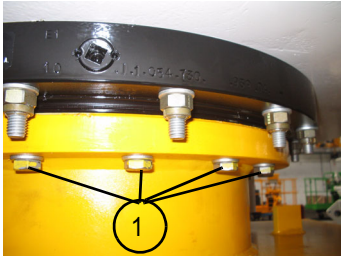

- Bring the electric wiring harnesses and hoses into the chassis or turntable.
- Put the turntable assembly into slings.
- Unscrew the screws and remove the flat washers fixing the slew ring on the chassis (see Photo 2).
- Remove the turntable assembly and place on suitable trestles (see Photo 5 and Photo 6).

Photo 5



Photo 6



Photo 3

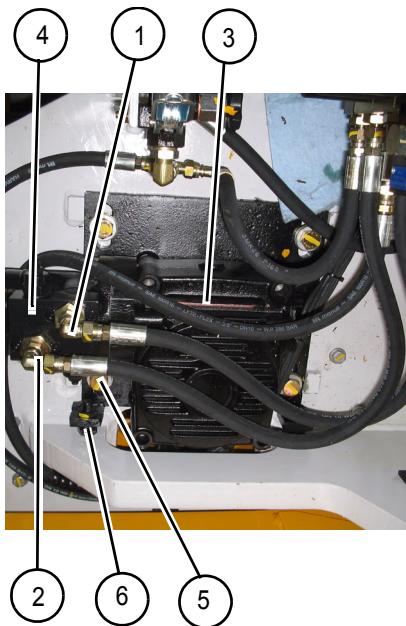
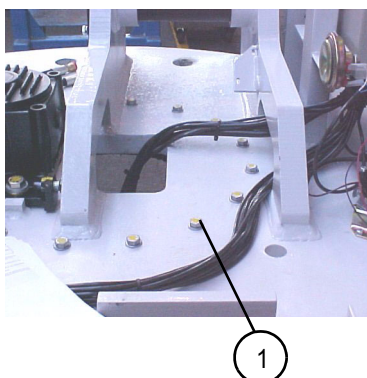

Photo 4



|            |                              |           |
|------------|------------------------------|-----------|
| Sheet C229 | CORRECTIVE MAINTENANCE SHEET | Folio 3/6 |
|            | REPLACING THE SLEW RING      |           |



**Caution!**

**For this operation, all the slew ring's fixing screws and washers must be replaced with new ones.**

**2 - Removing the ring**

- Mark, then disconnect the hoses (ref. 1 and 2 Photo 3) from the hydraulic motor (ref. 4 Photo 3) of the rotation reducer (ref. 3 Photo 3).
- Put caps on the connectors.

**NB:** *Unscrew the hoses slowly to release residual hydraulic pressure.*

- Unscrew the 4 screws (ref. 5 Photo 3) and washers fixing the reducer to the turntable.
- Unscrew the adjusting screws (ref. 6 Photo 3) on the reducer.
- Remove the reducer.
- Wedge on the ring onto the fork of a fork-lift truck and unscrew the screws and nuts (ref. 1 Photo 4) and washers holding the ring to the turntable.

Photo 9

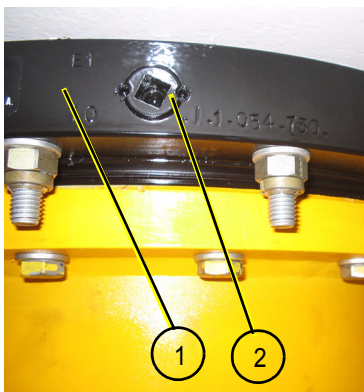

|            |                              |           |
|------------|------------------------------|-----------|
| Sheet C229 | CORRECTIVE MAINTENANCE SHEET | Folio 4/6 |
|            | REPLACING THE SLEW RING      |           |

### 3 - Reassembling a slew ring

- Position the ring on the turntable.
- Put the cap (ref. 2 Photo 9) in the zone not subject to the main loads (in the transversal axis of the turntable).
- Fix the ring with flat screws and washers (ref. 1 Photo 4).
- Tighten in a star pattern to a torque of 90 Nm.

*NB:* 4 Hm 12 100/30 screws are to be positioned in the spot facings under the rotation reducer).

- Re-position the rotation reducer without blocking it (if the pinion shows signs of wear, replace it).
- Remove the hydraulic motor (see relevant sheet) to enable ring rotation.
- Turn the reducer to position the teeth of the slew ring with coloured marks opposite the reducer pinion.

### 4 - Adjusting the clearance between the slew ring teeth and rotation reducer pinion

- The coloured mark corresponds to the most eccentric point of the ring. Adjust the gap between the teeth to 300 µm using a set of flakes.
- Adjust using the reducer's adjusting screws (ref. 6 Photo 3).
- When the gap is correct, block the 4 screws fixing the reducer to the turntable to a torque of 190 Nm.
- Tighten the counternuts of the reducer's adjusting screws.
- Turn the reducer to position the slew ring's tempering connection point marked with an S in the reducer axis.
- When placing the turntable on the chassis, make sure that the "S" point is in the zone not subject to the main loads (in the transversal axis of the chassis).

### 5 - Reassembling a slew ring (cont.)

- Mount the rotation reducer's hydraulic motor, and connect the hoses.
- Put the turntable into slings and position the assembly on the chassis (see Photo 2).

## **TAKE CARE NOT TO TRAP THE HYDRAULIC HOSES OR WIRING HARNESS DURING THIS OPERATION.**

- Fix the slew ring to the chassis with new flat washers and screws. Tighten to a torque of 90 Nm.
- Reconnect the hoses to the block movement (see Photo 1).
- Put back the counterweight (see relevant sheet).
- Put back the boom (see relevant sheet).
- Put back the covers (see relevant sheet).

|            |                              |           |
|------------|------------------------------|-----------|
| Sheet C229 | CORRECTIVE MAINTENANCE SHEET | Folio 5/6 |
|            | REPLACING THE SLEW RING      |           |

**6 - Additional operations**

- Reconnect the battery (see relevant sheet).
- Make turntable rotation, steering and travel movements, using all available speeds, to purge the hydraulic circuit.
- Top up with oil using the brand recommended by the manufacturer.
- Using greasers, grease the slew ring rolling path.
- Grease the teeth of the ring.

NB: *For the ring, only use the oil recommended by the manufacturer.*

---

|            |                              |           |
|------------|------------------------------|-----------|
| Sheet C229 | CORRECTIVE MAINTENANCE SHEET | Folio 6/6 |
|            | REPLACING THE SLEW RING      |           |

|            |   |           |
|------------|---|-----------|
| Sheet C230 | CORRECTIVE MAINTENANCE SHEET              | Folio 1/1 |
|            | REPLACING THE UNIT ACCU ON THE LOWER PART |           |



**Caution!**

Ensure that the oil is not too hot.



**Caution!**

Use a container to collect the oil to avoid pollution of the environment.

**1 - Preliminary operations**

- Ensure that the accumulator (1) is discharged or discharge it by activating the steering control in both directions, without pressing the pedal until the steering wheels are totally immobile
- Put the machine in the maintenance configuration (see relevant section).
- Switch off the electric power (see relevant section).

**2 - Removing the hydraulic accumulator**

- Unscrew the hydraulic accumulator (1).

*NB:* Unscrew slowly to release the residual hydraulic pressure.

- Put a cap on the connector (2).

**3 - Remounting the hydraulic accumulator**

- Put the hydraulic accumulator back into place.
- Put the machine back in the operational configuration.
- Make several steering cycles to purge the hydraulic circuit.

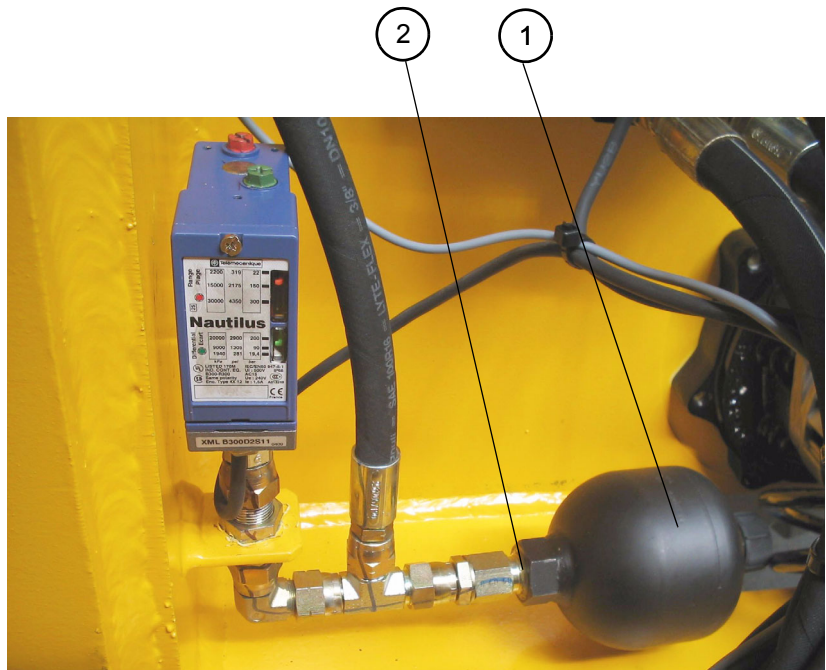



|            |                              |           |
|------------|------------------------------|-----------|
| SHEET C231 | CORRECTIVE MAINTENANCE SHEET | Folio 1/2 |
|            | REPLACING THE CONVERTER      |           |

**Caution!**  
*Safety gear must be used for all operations involving handling the batteries (protective gloves and goggles).*

**1 - Preliminary operations**

- Put the machine in the low configuration.
- Switch off the electric power (see relevant section).
- Disconnect the + and - terminals of the batteries to isolate the electric circuit (1).

**2 - Removing the converter**

- Mark and disconnect the converter's electric connections (2).
- Remove the converter (3&4).

**3 - Remounting the converter**

- Put the converter (4) into place and secure with fixing screws (3).
- Reconnect the converter's electric connections (2) according to the marks made during dismantling.
- Reconnect the + and - terminals of the batteries (1).
- Put the machine back in the operational configuration.

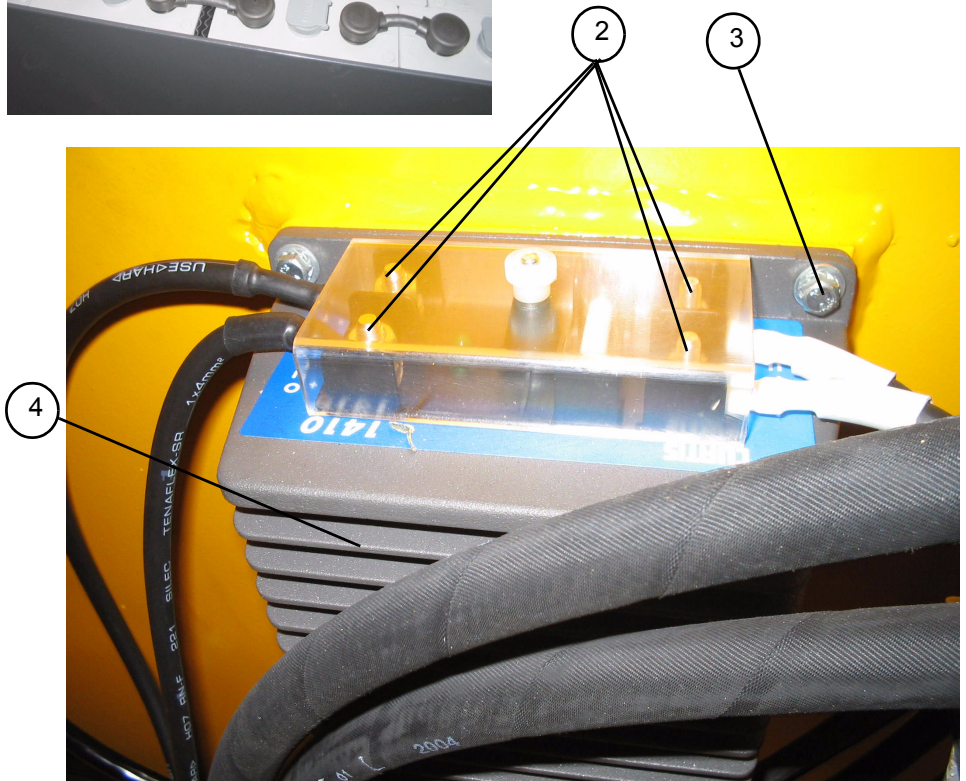



|            |                              |           |
|------------|------------------------------|-----------|
| SHEET C231 | CORRECTIVE MAINTENANCE SHEET | Folio 2/2 |
|            | REPLACING THE CONVERTER      |           |

|            |                               |           |
|------------|-------------------------------|-----------|
| Sheet C232 | CORRECTIVE MAINTENANCE SHEET  | Folio 1/1 |
|            | REPLACING THE PRESSURE SWITCH |           |



**Caution!**

Ensure that the oil is not too hot.



**Caution!**

Use a container to collect the oil to avoid pollution of the environment.



**Caution!**

Safety gear must be used for all operations requiring handling of the batteries (protective gloves and goggles).

**1 - Preliminary operations**

- Ensure that the accumulator (1) is discharged or discharge it by activating the steering control in both directions, without pressing the pedal until the steering wheels are totally immobile
- Put the machine in the maintenance configuration (see relevant section).
- Switch off the electric power (see relevant section).
- Disconnect the + and - terminals of the batteries to isolate the electric circuit (2).

**2 - Removing the pressure switch**

- Mark and disconnect the pressure switch's electric connections (3).
- Unscrew the pressure switch (4).

**NB:** *Unscrew slowly to release the residual hydraulic pressure.*

- Put a cap on the connector.

**3 - Remounting the pressure switch**

- Put the pressure switch back into place.
- Reconnect the pressure switch's electric connections (3) according to the marks made during dismantling
- Pressure switch settings (5): Max=150 & Min=90
- Reconnect the + and - terminals of the batteries (2).
- Put the machine back in the operational configuration.
- Make several steering cycles to purge the hydraulic circuit.

