

Part No.502003110002

Rev: A

Jul 2021

Maintenance Manual

1018RD/3369RD

1218RD/4069RD

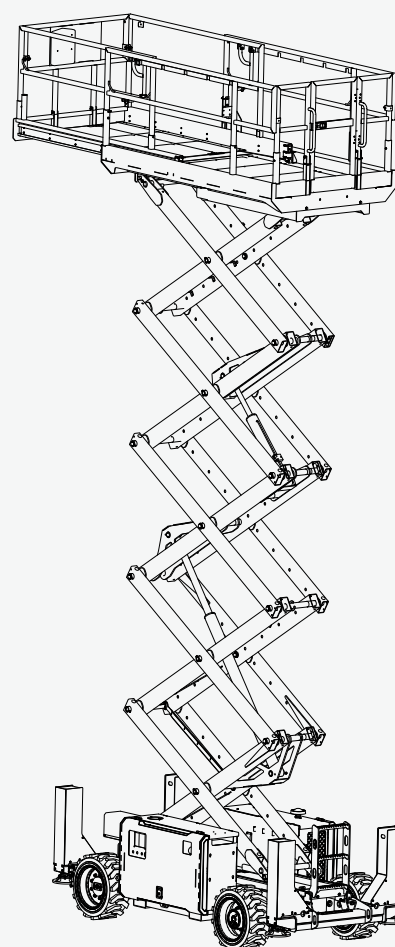

CE EAC **ANSI** 

SINOBOOM

 **WARNING**

Operating, servicing and maintaining this vehicle or equipment can expose you to chemicals including engine exhaust, carbon monoxide, phthalates, and lead, which are known to the State of California to cause cancer and birth defects or other reproductive harm. To minimize exposure, avoid breathing exhaust, do not idle the engine except as necessary, service your vehicle or equipment in a well-ventilated area and wear gloves or wash your hands frequently when servicing. For more information go to: www.P65warnings.ca.gov.

Manual revision history :

REV	DATE	DESCRIPTION	REMARK
A	Jul. 2021	Original issue	

Please contact us:

Website : www.sinoboom.com

E-mail : sales@sinoboom.com

Sales Tel : 0086-0731-87116222

Service Tel : 0086-0731-87116333

Address : No.128, East Jinzhou Avenue, Ningxiang High-tech Industrial Park, Changsha, Hunan, China

Zip Code : 410600

Copyright © Hunan Sinoboom Intelligent Equipment Co., Ltd. All Rights Reserved

The final interpretation right of this manual belongs to Hunan Sinoboom Intelligent Equipment Co., Ltd.

APPLICATION

Use the following table to identify the specific serial number for models included in this manual. Check the model of your machine before consulting the manual, and then use the correct manual according to the serial number of the model. See the nameplate on your machine to identify the model and serial number. (See *Decals/Nameplate Inspection* of the *Operation Manual* for details.)

Models	Trade Identification		Serial Numbers
	Metric	Imperial	
1018RD	1018RD	3369RD	0200300150 to present
1218RD	1218RD	4069RD	0200400200 to present

NOTE:

- Product model is applied in product nameplate for distinction of products of different main parameters.
- Product trade identification is applied in marketing and machine decals for distinction of products of different main parameters, and can be classified as metric type and imperial type: The metric type of trade identification is applicable to machines for countries/regions using metric system or as specially required by customers; The imperial type of trade identification is applicable to the machines for countries/regions using imperial system or as specially required by customers.

This Page Intentionally Left Blank

STATEMENTS

Hunan Sinoboom Intelligent Equipment Co., Ltd. (Hereinafter referred to as Sinoboom) will upload the latest product manual information to the website www.sinoboom.com as soon as possible. However, due to continuous product improvement, the information in this manual is subject to change without prior notice.

This manual covers the basic parts information of one or more products. Therefore, please use this manual according to your needs. If you find problems in the manual or have suggestions for improvement, feel free to share your feedback with Sinoboom, and we will address these issues as soon as possible.

Feel free to consult and download the *Operation Manual*, *Maintenance Manual* and *Parts Manual* of the products you need online at www.sinoboom.com.

Hunan Sinoboom Intelligent Equipment Co., Ltd. retains the right of final interpretation of the manual.

This Page Intentionally Left Blank

TABLE OF CONTENTS

Introduction	v	Safety Measures	3-1
1 Specifications	1-1	4 Service and Guidelines	4-1
Machine Specifications	1-1	Machine Preparation, Inspection and	
Engine Specifications	1-5	Maintenance	4-1
Power System Specifications	1-5	General	4-1
Hydraulic Hose and Fitting		Preparation, inspection and	
Specifications	1-6	maintenance	4-1
Hydraulic Hose Torque	1-6	Qualified Sinoboom equipment	
Hydraulic Fitting Torque	1-6	mechanic	4-1
Hydraulic Hose and Fitting Torque		Pre-operation inspection.....	4-1
Procedure	1-9	Pre-delivery inspection and	
Fastener Torque Specifications	1-9	frequent inspection	4-1
2 Safety	2-1	Annual machine inspection	4-1
Safety Definitions	2-1	Preventive maintenance	4-2
Reporting Accidents.....	2-1	Maintenance and Servicing	
Electrocution Hazards.....	2-1	Precautions	4-3
Tipping Hazards and Rated Load	2-2	General	4-3
Work Environment Hazards	2-4	Safety and workmanship	4-3
Unsafe Operation Hazards.....	2-5	Cleanliness	4-3
Fall Hazards.....	2-6	Component removal and installation	4-3
Collision Hazards	2-7	Component disassembly and	
Crush Hazards	2-8	assembly	4-4
Explosion and Fire Hazards	2-8	Pressure-fit parts	4-4
Damaged Machine Hazards	2-8	Bearings	4-4
Bodily Injury Hazards	2-8	Gaskets.....	4-4
Battery Hazards	2-9	Bolt usage and torque application ..	4-4
Hydraulic Systems Hazard.....	2-10	Hydraulic lines and electrical wiring	4-4
Welding and Polishing Requirements	2-10	Hydraulic system	4-4
After Using the Machine.....	2-11	Lubrication.....	4-4
3 System Descriptions	3-1	Battery	4-5
Power System.....	3-1	Pins and composite bearing.....	4-5
Hydraulic System	3-1	Application of Insulating Silicone	
Electrical System.....	3-1	Grease to Electrical Connections	4-5
Machine Control.....	3-1	5 Maintenance	5-1
		Conducting a Pre-delivery Inspection .	5-1

Following a Maintenance Schedule ...	5-2
Completing a Repair & Inspection Report.....	5-2
Checklist A Procedures	5-5
A-1 Inspect All Manuals.....	5-5
A-2 Inspect All Decals	5-5
A-3 Inspect Damaged, Loose or Lost Parts	5-5
A-4 Inspect Hydraulic Oil Level	5-6
A-5 Inspect Hydraulic Leakage	5-6
A-6 Inspect Fuel Level	5-6
A-7 Inspect Fuel Leakage	5-7
A-8 Inspect Engine Oil Level.....	5-8
A-9 Inspect Coolant Level	5-9
A-10 Inspect Engine Intake System	5-9
A-11 Inspect Engine Belt.....	5-10
A-12 Inspect Fuel Filter	5-10
A-13 Inspect Cooling Fan.....	5-11
A-14 Functional Tests.....	5-11
A-15 Perform Maintenance after 30 Days	5-13
Checklist B Procedures	5-13
B-1 Inspect Electrical Wiring.....	5-13
B-2 Inspect Rim, Tire and Fasteners	5-13
B-3 Inspect Hydraulic Oil	5-13
B-4 Inspect Cooling System	5-14
B-5 Replace Fuel filter Element.....	5-14
B-6 Inspect Air filter of Hydraulic Tank	5-14
B-7 Replace High-Pressure Filter Element	5-15
B-8 Replace Engine Air Filter Element	5-15
B-9 Inspect the Battery	5-16
B-10 Inspect Engine Exhaust System.....	5-16
B-11 Inspect Drive Reducer Oil Level.....	5-16

B-12 Test Oscillate Outriggers	5-17
B-13 Test Drive Speed.....	5-17
B-14 Test Tilt Protection System...	5-18
B-15 Test Brake Distance.....	5-18
Checklist C Procedures	5-19
C-1 Replace Fuel Filter Element...	5-19
C-2 Replace Engine Oil.....	5-19
C-3 Replace Engine Oil Filter.....	5-20
C-4 Test Weighing System.....	5-20
C-5 Test Secondary Lowering	5-21
Checklist D Procedures	5-21
D-1 Replace Drive Reducer Gear Oil.....	5-21
D-2 Inspect Scissor Arm Sliders ...	5-22
D-3 Replace Hydraulic Oil	5-22
D-4 Replace Hydraulic Tank Suction Filter.....	5-23
D-5 Inspect Scissor Arm Bearings.	5-23
6 Repair.....	6-1
Platform Components	6-1
Platform Controller.....	6-1
Platform Assembly.....	6-1
Extension Platform	6-2
Scissor Components	6-2
Scissor Assembly.....	6-2
Lift Cylinder	6-3
Chassis Components	6-3
Tires and Rims.....	6-3
Reducer and Rear Drive Motor	6-5
Front Drive Motor	6-5
Steer Cylinder	6-6
Steer Linkage	6-6
Oscillate Cylinder	6-6
Ground Controller.....	6-7
Hydraulic System	6-8
Layout of Hydraulic Elements.....	6-8
Hydraulic Tank.....	6-9
Hydraulic Pump.....	6-9
Function Valves.....	6-10

Hydraulic Symbols.....6-18
Hydraulic Schematic.....6-19
Electrical System.....6-21
Fault Code Description6-21
Use and Maintenance of Battery...6-23
Electrical Symbols6-23
Electrical Schematic6-25

Appendix 1: Prepare the Work

Record Before Delivery A-1

Appendix 2: Repair & Inspection

Report A-3

INTRODUCTION

Thank you for choosing and using the machinery of Hunan Sinoboom Intelligent Equipment Co., Ltd. Always read, understand and become familiar with the operation requirements of the machine and its associated safety procedures before operating, maintaining and repairing the machine. Operating the machine without becoming familiar with its specific operation requirements and safety procedures poses serious risks. Operators who follow safety rules and operate the machine carefully and effectively will prevent personal injury, property loss and accidents.

Use this machine only to transport tools to work locations and for performing tasks on the work platform. Operators must be competent and must obtain training to carefully use the machine and follow safety procedures. Only trained and authorized personnel may operate the machine.

This manual guides the operator and authorized personnel in maintaining the machine. The operator is responsible for reading, understanding and implementing the maintenance and safety procedures in this manual and for following the manufacturer's instructions before beginning any work. Read, understand and follow all safety rules and operating instructions. The operator must also consider the machine's uses and limitations and the conditions at the jobsite before using this machine. Strictly following all safety requirements in this manual is critical.

Consider this manual a part of the machine, along with *Operation Manual* and *Parts Manual*, and always keep the manuals with the machine. The owner or administrator of the machine shall offer all manuals and other necessary information provided by the machine manufacturer regarding the daily inspection and maintenance to each of the renters. If the machine is sold, the owner or administrator must pass along the manuals and other necessary information to the purchaser. The owner or administrator of the machine shall also provide the manufacturer's maintenance information to the person responsible for maintaining the machine.

If you have any questions, contact Hunan Sinoboom Intelligent Equipment Co., Ltd..

This Page Intentionally Left Blank

1 SPECIFICATIONS

MACHINE SPECIFICATIONS

Table 1-1 1018RD specifications

MEASURE	1018RD (METRIC)	3369RD (IMPERIAL)
DIMENSION		
Max platform height	10 m	32ft 9.7in
Max working height	12 m	39ft 4.4in
Max horizontal reach	1.5 m	4ft 11.1in
Overall length (stowed, with/without outriggers)	3.8 m/3.19 m	12ft 5.6in/10ft 5.6in
Overall width (stowed)	1.78 m	5ft 10in
Overall height (stowed with rails folded)	1.94 m	6ft 4.4in
Overall height (stowed with rails not folded)	2.56 m	8ft 4.8in
Wheelbase	2.28 m	7ft 5.8in
Ground clearance	0.22 m	8.66in
Tire size (spec/type)	26×12-16.5/solid or foam-filled	
Platform dimension (L × W × H)	2.8×1.6×1.1 m	9.2×5.2×3.6 ft
PERFORMANCE		
Rated platform capacity	450 kg	992 lb
Max capacity of extension platform	140 kg	309 lb
Max. platform occupancy(indoor/ outdoor)	4P/2P	
Drive speed (stowed)	0 ~ 5.6 km/h	0 ~ 3.5 mph
Drive speed (raised)	0 ~ 0.48 km/h	0 ~ 0.3 mph
Up time (no-load)	34 ~ 44 s	
Down time (no-load)	40 ~ 45 s	
Gradeability	35% (19°)	
Max. allowable inclination (front-to-back)	3°	
Max allowable inclination (side-to-side, outrigger retracted/extended))	2°/0.8°	
Max outrigger leveling (front-to-back)	5.3° (front)/4.2° (back)	

MEASURE	1018RD (METRIC)	3369RD (IMPERIAL)
Max outrigger leveling (side-to-side)	11.7°	
Turning radius (inside)	2.11 m	6ft 11.1in
Turning radius (outside)	4.6 m	15ft 1.1in
Max allowable side force (indoor/outdoor)	400 N	90 lbf
Max operating noise	82 dB	
POWER		
Drive mode (drive×steer)	4WD×2WS	
Engine specs (rated power, rpm)	18.5 kW , 3000 rpm (Kubota)	
Fuel tank capacity-diesel	48 L	10.6 gal (UK)/12.7 gal (US)
Hydraulic tank capacity	72 L	15.8 gal (UK)/19 gal (US)
Hydraulic system capacity (-including tank)	90 L	19.8 gal (UK)/23.8 gal (US)
Hydraulic system pressure	21 MPa	3045 Psi
Battery specs (quantity × voltage, capacity)	1×12V, 60Ah	
System voltage	12 VDC	
Control voltage	12 VDC	
GROUND BEARING DATA		
Max tire load	2400 kg	5291 lb
Tire contact pressure	630 KPa	91 Psi
Max outrigger load	2300 kg	7055 lb
Outrigger contact pressure	460 KPa	91 Psi
ENVIRONMENT		
Max allowable wind speed (indoor/outdoor)	0m/s (indoor)/12.5m/s (outdoor)	0 mph (indoor)/28 mph (outdoor)
Max allowable altitude	1000m	3280.8ft
Allowable ambient temperature (lead-acid batteries)	-10°C ~ 40°C	14°F ~ 104°F
Allowable ambient temperature (-lithium batteries)	-20°C ~ 40°C	-4°F ~ 104°F
Max allowable RH	90%	
Storage condition	Stored at -20°C to 50°C(-4°F to 122°F) in a well-ventilated environment with 90% relative humidity (20°C [68°F]), and away from rain, sun, corrosive gas and inflammable explosive.	
WEIGHT		
Gross weight (with/without outriggers)	4110 kg/3650 kg	9061 lb/8046 lb

Table 1-2 1218RD specifications

MEASURE	1218RD (METRIC)	4069RD (IMPERIAL)
DIMENSION		
Max platform height	12.2 m	40ft 0.3in
Max working height	14.2 m	46ft 10.7in
Max horizontal reach	1.5 m	4ft 11.1in
Overall length (stowed, with/without outriggers)	3.8 m/3.19 m	12ft 5.6in/10ft 5.6in
Overall width (stowed)	1.78 m	5ft 10in
Overall height (stowed with rails folded)	2.1 m	6ft 10.7in
Overall height (stowed with rails not folded)	2.73 m	8ft 11.5in
Wheelbase	2.28 m	7ft 5.8in
Ground clearance	0.22 m	8.66in
Tire size (spec/type)	26×12-16.5/solid or foam-filled	
Platform dimension (L × W × H)	2.8×1.6×1.1 m	9.2×5.2×3.6 ft
PERFORMANCE		
Rated platform capacity	365 kg	805 lb
Max capacity of extension platform	140 kg	309 lb
Max. platform occupancy(indoor/outdoor)	3P/2P	
Drive speed (stowed)	0 ~ 5.6 km/h	0 ~ 3.5 mph
Drive speed (raised)	0 ~ 0.48 km/h	0 ~ 0.3 mph
Up time (no-load)	55 ~ 65 s	
Down time (no-load)	40 ~ 50 s	
Gradeability	35% (19°)	
Max. allowable inclination (front-to-back)	3°	
Max allowable inclination (side-to-side, outrigger retracted/extended))	2°/0.8°	
Max outrigger leveling (front-to-back)	5.3° (front)/4.2° (back)	
Max outrigger leveling (side-to-side)	11.7°	
Turning radius (inside)	2.11 m	6ft 11.1in
Turning radius (outside)	4.6 m	15ft 1.1in
Max allowable side force (indoor/outdoor)	400 N	90 lbf
Max operating noise	82 dB	

MEASURE	1218RD (METRIC)	4069RD (IMPERIAL)
POWER		
Drive mode (drive×steer)	4WD×2WS	
Engine specs (rated power, rpm)	18.5 kW , 3000 rpm (Kubota)	
Fuel tank capacity-diesel	48 L	10.6 gal (UK)/12.7 gal (US)
Hydraulic tank capacity	72 L	15.8 gal (UK)/19 gal (US)
Hydraulic system capacity (including tank)	95 L	20.9 gal (UK)/25.1 gal (US)
Hydraulic system pressure	21 MPa	3045 Psi
Battery specs (quantity × voltage, capacity)	1×12V, 60Ah	
System voltage	12 VDC	
Control voltage	12 VDC	
GROUND BEARING DATA		
Max tire load	2400 kg	5291 lb
Tire contact pressure	630 KPa	91 Psi
Max outrigger load	2300 kg	7055 lb
Outrigger contact pressure	460 KPa	91 Psi
ENVIRONMENT		
Max allowable wind speed (indoor/ outdoor)	0m/s (indoor)/12.5m/s (outdoor)	0 mph (indoor)/28 mph (outdoor)
Max allowable altitude	1000m	3280.8ft
Allowable ambient temperature (lead-acid batteries)	-10°C ~ 40°C	14°F ~ 104°F
Allowable ambient temperature (- lithium batteries)	-20°C ~ 40°C	-4°F ~ 104°F
Max allowable RH	90%	
Storage condition	Stored at -20°C to 50°C(-4°F to 122°F) in a well-ventilated environment with 90% relative humidity (20°C [68°F]), and away from rain, sun, corrosive gas and inflammable explosive.	
WEIGHT		
Gross weight (with/without outriggers)	5180kg/4720kg	11420 lb/10406 lb

Note :

- a) The working height adds 2m (6ft 7in) of human height to platform height.
- b) In different areas, hydraulic oil, engine oil, coolant, fuel and lubrication should be added in accordance with the environmental temperature.
- c) In cold weather, auxiliary devices are needed to start the machines.
- d) The ground bearing data is approximate values not considering different options and only used when it is safe enough.
- e) The loads of persons, accessories, tools and materials are factored into the rated platform capacity.

ENGINE SPECIFICATIONS

Table 1-3 Kubota D1105-E4B-EU-X1

Type	Inline, water-cooled, 4-stroke
Number of Cylinders	3
Bore	78mm (3.1 in)
Stroke	78.4mm (3.1 in)
Total Displacement	1.123L 0.25 gal (Imperial) 0.3 gal (US)

Compression Ratio	24 : 1
Firing Order	1-2-3
Output	18.5kw@3000rpm
Torque	71.5Nm (52.7 ft-lb) @2200rpm
Low idle	850rpm
Alternator	12V-40A

POWER SYSTEM SPECIFICATIONS

Table 1-4

ITEM	SPECIFICATION
Hydraulic oil	
Normal temperature region (0°C~40°C [32°F~104°F])	L-HM46
Cold temperature region (-25°C~25°C [-13°F~77°F])	L-HV32
High temperature region (> 40°C [104°F])	L-HM68
Extremely cold temperature region (< -30°C [-22°F])	Special program to be determined
Hydraulic Pump	
Type	Gear pump
Displacement	16 cc/r
Max drive pressure	28 MPa (4061 Psi)
Drive motor	
Front drive motor type	Cyloidal motor
Front drive motor displacement	275 cc/r
Rear drive motor type	Variable-displacement plunger motor
Rear drive motor displacement	9.5/25 cc/r
Function Manifold	
System relief valve pressure	21 MPa (2046 Psi)
Lift relief valve pressure	19.7 MPa (2857 Psi)
Steer relief valve pressure	21 MPa (2046 Psi)
Drive relief valve pressure	21 MPa (2046 Psi)
Drive brake engage pressure	3.5 MPa (508 Psi)

ITEM	SPECIFICATION
Return Filter	
Return filter bypass pressure	0.25 MPa (36.3 Psi)

NOTICE

The factory-filled hydraulic oil can be selected to suit the customer's demand. Do not intermix different types of hydraulic oil.

HYDRAULIC HOSE AND FITTING SPECIFICATIONS

HYDRAULIC HOSE TORQUE

Hydraulic hoses must be torqued to the following specifications.

Table 1-5 Hydraulic Hose Torque

METRIC THREAD	L (LIGHT-DUTY)	S (HEAVY-DUTY)
M12 × 1.5	19 ± 1 Nm (14 ± 1 ft-lb)	
M14 × 1.5	26 ± 2 Nm (19 ± 2 ft-lb)	
M16 × 1.5	40 ± 3 Nm (30 ± 2 ft-lb)	
M18 × 1.5	50 ± 4 Nm (37 ± 3 ft-lb)	
M20 × 1.5	-	60 ± 4 Nm (44 ± 3 ft-lb)
M22 × 1.5	70 ± 5 Nm (52 ± 4 ft-lb)	-
M24 × 1.5	-	85 ± 6 Nm (63 ± 4 ft-lb)
M26 × 1.5	90 ± 6 Nm (66 ± 4 ft-lb)	-
M30 × 2	120 ± 8 Nm (89 ± 6 ft-lb)	140 ± 10 Nm (103 ± 7 ft-lb)
M36 × 2	150 ± 12 Nm (111 ± 9 ft-lb)	180 ± 12 Nm (133 ± 9 ft-lb)
M42 × 2	-	260 ± 16 Nm (192 ± 12 ft-lb)
M45 × 2	240 ± 15 Nm (177 ± 11 ft-lb)	-
M52 × 2	250 ± 16 Nm (184 ± 12 ft-lb)	280 ± 18 Nm (207 ± 13 ft-lb)

HYDRAULIC FITTING TORQUE

Hydraulic fittings with metric thread must be torqued to the following specifications.

Table 1-6 Hydraulic Fitting Torque – Metric

THREAD SIZE	INSTALLED INTO ALUMINUM	INSTALLED INTO STEEL	
	ED, O-RING + CIRCLIP	ED, O-RING + CIRCLIP	O-RING
L (LIGHT-DUTY)			
M10×1	18 ± 1 Nm (13 ± 1 ft-lb)	20 ± 2 Nm (15 ± 2 ft-lb)	18 ± 1 Nm (13 ± 1 ft-lb)
M12×1.5	30 ± 2 Nm (22 ± 2 ft-lb)	35 ± 2 Nm (26 ± 2 ft-lb)	30 ± 2 Nm (22 ± 2 ft-lb)
M14×1.5	42 ± 3 Nm (31 ± 2 ft-lb)	48 ± 4 Nm (35 ± 3 ft-lb)	35 ± 2 Nm (26 ± 2 ft-lb)
M16×1.5	55 ± 4 Nm (41 ± 3 ft-lb)	60 ± 4 Nm (44 ± 3 ft-lb)	40 ± 3 Nm (30 ± 3 ft-lb)
M18×1.5	75 ± 5 Nm (55 ± 4 ft-lb)	75 ± 5 Nm (55 ± 4 ft-lb)	45 ± 3 Nm (33 ± 4 ft-lb)
M22×1.5	90 ± 6 Nm (66 ± 4 ft-lb)	130 ± 8 Nm (96 ± 6 ft-lb)	60 ± 4 Nm(44 ± 3 ft-lb)
M27×2	120 ± 8 Nm (89 ± 6 ft-lb)	185 ± 12 Nm (136 ± 9 ft-lb)	100 ± 7 Nm (74 ± 5 ft-lb)
M30×2	140 ± 8 Nm (103 ± 6 ft-lb)	245 ± 15 Nm (181 ± 11 ft-lb)	135 ± 8 Nm (100 ± 6 ft-lb)
M33×2	180 ± 10 Nm (133 ± 7 ft-lb)	320 ± 20 Nm (236 ± 15 ft-lb)	160 ± 10 Nm(118 ± 7 ft-lb)
M42×2	240 ± 15 Nm (177 ± 11 ft-lb)	450 ± 25 Nm (332 ± 18 ft-lb)	210 ± 13 Nm (155 ± 10 ft-lb)
M48×2	280 ± 20 Nm (207 ± 15 ft-lb)	540 ± 30 Nm (398 ± 22 ft-lb)	260 ± 15 Nm (192 ± 11 ft-lb)
S (HEAVY-DUTY)			
M12×1.5	33 ± 2 Nm (24 ± 2 ft-lb)	43 ± 3 Nm (32 ± 2 ft-lb)	35 ± 2 Nm (26 ± 2 ft-lb)
M14×1.5	42 ± 3 Nm (31 ± 2 ft-lb)	50 ± 4 Nm (37 ± 3 ft-lb)	45 ± 3 Nm (33 ± 2 ft-lb)
M16×1.5	55 ± 4 Nm (41 ± 3 ft-lb)	75 ± 5 Nm (55 ± 4 ft-lb)	55 ± 4 Nm (41 ± 3 ft-lb)
M18×1.5	75 ± 5 Nm (55 ± 4 ft-lb)	95 ± 6 Nm (70 ± 4 ft-lb)	70 ± 5 Nm (52 ± 4 ft-lb)
M22×1.5	90 ± 6 Nm (66 ± 4 ft-lb)	140 ± 8 Nm(103 ± 6 ft-lb)	100 ± 10 Nm (74 ± 7 ft-lb)
M27×2	120 ± 8 Nm (89 ± 6 ft-lb)	185 ± 12 Nm (136 ± 9 ft-lb)	160 ± 10 Nm (118 ± 7 ft-lb)
M30×2	140 ± 8 Nm (103 ± 6 ft-lb)	245 ± 15 Nm (181 ± 11 ft-lb)	210 ± 13 Nm (155 ± 10 ft-lb)
M33×2	180 ± 10 Nm (133 ± 7 ft-lb)	320 ± 20 Nm (236 ± 15 ft-lb)	260 ± 15 Nm (192 ± 11 ft-lb)
M42×2	240 ± 15 Nm (177 ± 11 ft-lb)	450 ± 25 Nm (332 ± 18 ft-lb)	330 ± 20 Nm (243 ± 15 ft-lb)
M48×2	280 ± 20 Nm (207 ± 15 ft-lb)	540 ± 30 Nm (398 ± 22 ft-lb)	420 ± 25 Nm (310 ± 18 ft-lb)

Hydraulic fittings with inch thread (British Standard Pipe [BSP]) must be torqued to the following specifications.

Table 1-7 Hydraulic Fitting Torque – British Standard Pipe (BSP)

THREAD SIZE	INSTALLED INTO ALUMINUM	INSTALLED INTO STEEL	
	ED, O-RING + CIRCLIP	ED, O-RING + CIRCLIP	O-RING
L (LIGHT-DUTY)			
G1/8A	20 ± 1 Nm (15 ± 1 ft-lb)	20 ± 1 Nm (15 ± 1 ft-lb)	-

THREAD SIZE	INSTALLED INTO ALUMINUM	INSTALLED INTO STEEL	
	ED, O-RING + CIRCLIP	ED, O-RING + CIRCLIP	O-RING
G1/4A	35 ± 2 Nm (26 ± 2 ft-lb)	40 ± 2 Nm (30 ± 2 ft-lb)	-
G3/8A	50 ± 3 Nm (37 ± 2 ft-lb)	75 ± 5 Nm (55 ± 2 ft-lb)	-
G1/2A	75 ± 5 Nm (55 ± 2 ft-lb)	95 ± 6 Nm (70 ± 4 ft-lb)	-
G3/4A	120 ± 8 Nm (89 ± 6 ft-lb)	185 ± 12 Nm (136 ± 9 ft-lb)	-
G1A	180 ± 10 Nm (133 ± 7 ft-lb)	320 ± 20 Nm (236 ± 15 ft-lb)	-
G1-1/4A	240 ± 15 Nm (177 ± 11 ft-lb)	450 ± 25 Nm (332 ± 18 ft-lb)	-
G1-1/2A	280 ± 20 Nm (207 ± 15 ft-lb)	540 ± 30 Nm (398 ± 22 ft-lb)	-
S (HEAVY-DUTY)			
G1/4A	40 ± 3 Nm (30 ± 2 ft-lb)	43 ± 3 Nm (32 ± 2 ft-lb)	-
G3/8A	55 ± 3 Nm (41 ± 2 ft-lb)	85 ± 5 Nm (63 ± 4 ft-lb)	-
G1/2A	80 ± 5 Nm (59 ± 4 ft-lb)	120 ± 8 Nm (89 ± 6 ft-lb)	-
G3/4A	120 ± 8 Nm (89 ± 6 ft-lb)	185 ± 12 Nm (136 ± 9 ft-lb)	-
G1A	180 ± 10 Nm (133 ± 7 ft-lb)	320 ± 20 Nm (236 ± 15 ft-lb)	-
G1-1/4A	240 ± 15 Nm (177 ± 11 ft-lb)	450 ± 25 Nm (332 ± 18 ft-lb)	-
G1-1/2A	280 ± 20 Nm (207 ± 15 ft-lb)	540 ± 30 Nm (398 ± 22 ft-lb)	-

Hydraulic fittings with Unified Thread Standard (UNC/UNF) must be torqued to the following specifications.

Table 1-8 Hydraulic Fitting Torque – Unified Thread Standard (UNC/UNF)

THREAD SIZE	INSTALLED INTO ALUMINUM	INSTALLED INTO STEEL
	O-RING	O-RING
L (LIGHT-DUTY)		
7/16-20	21 ± 2 Nm (15 ± 2 ft-lb)	21 ± 2 Nm (15 ± 2 ft-lb)
9/16-18	34 ± 2 Nm (25 ± 2 ft-lb)	35 ± 2 Nm (26 ± 2 ft-lb)
11/16-12	40 ± 3 Nm (30 ± 2 ft-lb)	50 ± 4 Nm (37 ± 3 ft-lb)
3/4-16	50 ± 3 Nm (37 ± 2 ft-lb)	65 ± 4 Nm (48 ± 3 ft-lb)
7/8-14	75 ± 5 Nm (55 ± 4 ft-lb)	110 ± 8 Nm (81 ± 6 ft-lb)
1-1/16-12	110 ± 8 Nm (81 ± 6 ft-lb)	140 ± 10 Nm (103 ± 7 ft-lb)
1-5/16-12	160 ± 10 Nm (118 ± 7 ft-lb)	210 ± 15 Nm (155 ± 11 ft-lb)
S (HEAVY-DUTY)		
7/16-20	21 ± 2 Nm (15 ± 2 ft-lb)	23 ± 2 Nm (17 ± 2 ft-lb)
9/16-18	34 ± 2 Nm (25 ± 2 ft-lb)	40 ± 3 Nm (30 ± 2 ft-lb)

THREAD SIZE	INSTALLED INTO ALUMINUM	INSTALLED INTO STEEL
	O-RING	O-RING
11/16-12	40 ± 3 Nm (30 ± 2 ft-lb)	65 ± 4 Nm (48 ± 3 ft-lb)
3/4-16	50 ± 3 Nm (37 ± 2 ft-lb)	80 ± 6 Nm (59 ± 4 ft-lb)
7/8-14	75 ± 5 Nm(55 ± 4 ft-lb)	125 ± 10 Nm (92 ± 7 ft-lb)
1-1/16-12	110 ± 8 Nm (81 ± 6 ft-lb)	185 ± 15 Nm (136 ± 11 ft-lb)
1-5/16-12	160 ± 10 Nm (118 ± 7 ft-lb)	280 ± 20 Nm (207 ± 15 ft-lb)

HYDRAULIC HOSE AND FITTING TORQUE PROCEDURE

The hydraulic hose and fitting must be torqued to the following requirements when they are installed.

1. Replace the O-ring if damaged. The O-ring cannot be reused if the fitting or hose end has been tightened beyond finger tight.
2. Lubricate the O-ring before installation.
3. Properly seat the O-ring.
4. Position the tube and nut squarely on the fitting. Then tighten the nut as required.
5. Tighten the nut or fitting to the torque specified in the appropriate table.
6. Operate all machine functions and inspect the hose, fittings and related components to confirm there are no leaks.

FASTENER TORQUE SPECIFICATIONS

Unless special torque requirements are stated in this manual or other instructions, torque metric bolts to the values listed in the table below.

Table 1-9 Fastener Torque Specifications – Metric

NOMINAL DIAMETER (MM)	PITCH (MM)	CLASS 8.8	CLASS 10.9	CLASS 12.9
5	0.8	7 Nm (5 ft-lb)	9 Nm (7 ft-lb)	10 Nm (7 ft-lb)
6	1	12 Nm (9 ft-lb)	15 Nm (11 ft-lb)	18 Nm (13 ft-lb)
8	1.25	30 Nm (22 ft-lb)	35 Nm (26 ft-lb)	42 Nm (31 ft-lb)
	1	30 Nm (22 ft-lb)	37 Nm (27 ft-lb)	45 Nm (33 ft-lb)
10	1.5	55 Nm (41 ft-lb)	75 Nm (55 ft-lb)	85 Nm (63 ft-lb)
	1.25	56 Nm (41 ft-lb)	77 Nm (57 ft-lb)	87 Nm (64 ft-lb)
	1	60 Nm (44 ft-lb)	80 Nm (59 ft-lb)	92 Nm (68 ft-lb)
12	1.75	95 Nm (70 ft-lb)	125 Nm (92 ft-lb)	150 Nm (111 ft-lb)
	1.5	100 Nm (74 ft-lb)	130 Nm (96 ft-lb)	155 Nm (114 ft-lb)
	1.25	105 Nm (77 ft-lb)	135 Nm (100 ft-lb)	160 Nm (118 ft-lb)
14	2	150 Nm (110 ft-lb)	200 Nm (148 ft-lb)	230 Nm (170 ft-lb)
	1.5	165 Nm (122 ft-lb)	210 Nm (155 ft-lb)	250 Nm (184 ft-lb)

NOMINAL DIAMETER (MM)	PITCH (MM)	CLASS 8.8	CLASS 10.9	CLASS 12.9
16	2	230 Nm (170 ft-lb)	300 Nm (221 ft-lb)	360 Nm (266 ft-lb)
	1.5	250 Nm (184 ft-lb)	320 Nm (236 ft-lb)	380 Nm (280 ft-lb)
18	2.5	320 Nm (236 ft-lb)	420 Nm (310 ft-lb)	500 Nm (369 ft-lb)
	1.5	360 Nm (266 ft-lb)	470 Nm (345 ft-lb)	550 Nm (406 ft-lb)
20	2.5	450 Nm (332 ft-lb)	600 Nm (443 ft-lb)	700 Nm (516 ft-lb)
	1.5	500 Nm (369 ft-lb)	650 Nm (479 ft-lb)	770 Nm (568 ft-lb)
22	2.5	600 Nm (443 ft-lb)	800 Nm (590 ft-lb)	980 Nm (723 ft-lb)
	2	650 Nm (479 ft-lb)	850 Nm (627 ft-lb)	1050 Nm (774 ft-lb)
24	3	750 Nm (553 ft-lb)	1050 Nm (774 ft-lb)	1250 Nm (923 ft-lb)
	2	800 Nm (590 ft-lb)	1100 Nm (811 ft-lb)	1300 Nm (959 ft-lb)
27	3	1150 Nm (848 ft-lb)	1500 Nm (1106 ft-lb)	1800 Nm (1327 ft-lb)
30	3.5	1500 Nm (1106 ft-lb)	2000 Nm (1475 ft-lb)	2400 Nm (1770 ft-lb)

Unless special torque requirements are listed in this manual or other instructions, torque Unified Thread Standard bolts (label: UNC) to the values listed in the table below.

Table 1-10 Bolt Torque Specifications Unified – Thread Standard (UNC)

NOMINAL DIAMETER (IN)	OPPOSITE NUT SIZE (S)	CLASS 5	CLASS 8
1/4-20	7/16"	10 Nm (7 ft-lb)	14 Nm (10 ft-lb)
5/16-18	1/2"	21 Nm (15 ft-lb)	29 Nm (21 ft-lb)
3/8-16	9/16"	37 Nm (27 ft-lb)	51 Nm (38 ft-lb)
7/16-14	5/8"	60 Nm (44 ft-lb)	82 Nm (60 ft-lb)
1/2-13	3/4"	90 Nm (66 ft-lb)	130 Nm (96 ft-lb)
9/16-12	13/16"	130 Nm (96 ft-lb)	180 Nm (133 ft-lb)
5/8-11	15/16"	178 Nm (131 ft-lb)	250 Nm (184 ft-lb)
3/4-10	1-1/8"	315 Nm (232 ft-lb)	445 Nm (328 ft-lb)
7/8-9	-	509 Nm (375 ft-lb)	715 Nm (527 ft-lb)

Unless special torque requirements are listed in this manual or other instructions, torque Unified Thread Standard bolts (label: UNF) to the values listed in the table below.

Table 1-11 Bolt Torque Specifications – Thread Standard (UNF)

NOMINAL DIAMETER (IN)	OPPOSITE NUT SIZE (S)	CLASS 5	CLASS 8
1/4-28	7/16"	11.5 Nm (8 ft-lb)	16 Nm (11 ft-lb)
5/16-24	1/2"	23 Nm (17 ft-lb)	32 Nm (24 ft-lb)
3/8-24	9/16"	41 Nm (30 ft-lb)	58 Nm (43 ft-lb)
7/16-20	5/8"	65 Nm (48 ft-lb)	92 Nm (68 ft-lb)
1/2-20	3/4"	100 Nm (74 ft-lb)	145 Nm (107 ft-lb)
9/16-18	13/16"	145 Nm (107 ft-lb)	200 Nm (148 ft-lb)
5/8-18	15/16"	200 Nm (148 ft-lb)	280 Nm (207 ft-lb)
3/4-16	1-1/8"	350 Nm (258 ft-lb)	495 Nm (365 ft-lb)
7/8-14	-	560 Nm (413 ft-lb)	780 Nm (575 ft-lb)

This Page Intentionally Left Blank

2 SAFETY

Read, understand and comply with the safety rules and regulations of your workplace and your government.

Before using the machine, obtain proper training on safe machine operation and make sure you can safely control and operate the machine.

Understand that as the operator you have the responsibility and right to shut down the machine in case of failure with the machine or other emergency at your workplace.

NOTICE

People suffering from heart disease, hypertension, epilepsy and other diseases and people who fear heights must never operate or use this machine. Also, people who have alcohol or drugs in their system, or experience excessive fatigue or depression, are prohibited from operating or using this machine.

SAFETY DEFINITIONS



This safety alert symbol appears with most safety statements. It means attention, become alert, your safety is involved! Please read and abide by the message that follows the safety alert symbol.

DANGER

Indicates a hazardous situation that, if not avoided, **will** result in death or serious injury.

WARNING

Indicates a hazardous situation that, if not avoided, **could** result in death or serious injury.

CAUTION

Indicates a hazardous situation that, if not avoided, **could** result in minor or moderate injury.

NOTICE

Indicates a situation that can cause damage to the engine, personal property and/or the environment, or cause the equipment to operate improperly.

NOTE: Indicates a procedure, practice or condition that should be followed in order for the engine or component to function in the manner intended.

REPORTING ACCIDENTS

In case of any accident involving the machinery of Hunan Sinoboom Intelligent Equipment Co., Ltd., notify Hunan Sinoboom Intelligent Equipment Co., Ltd. Immediately, even if no personal injury or property damage occurs during the accident. Contact Hunan Sinoboom Intelligent Equipment Co., Ltd. by telephone and provide all necessary details. Failure to notify the manufacturer within 48 hours of the incident involving the machinery of Hunan Sinoboom Intelligent Equipment Co., Ltd. may void the product's warranty.





NOTICE

Thoroughly inspect the machine and all its functions after any accident, being sure to test first from the ground controller and then from the platform controller. Ensure the machine's lifting height does not exceed 3 m (9.8 ft) until all damage has been repaired and all controllers operate properly.

ELECTROCUTION HAZARDS

NOTE: This machine is not insulated and does not have an electric shock protection function.

All operators and managers shall comply with national or local regulations regarding the minimum safe distance of live conductors above the ground. In the absence of such requirements, operators and managers should follow the minimum safety distance requirements in [Table 2-1](#), [page 2-2](#).

 WARNING	
ELECTRICAL SHOCK HAZARDS	
  	<ul style="list-style-type: none"> • Always maintain a safe distance from power lines and electrical equipment in accordance with applicable government regulations and see Table 2-1 , page 2-2. • Consider platform movement, wire swinging or drooping, beware of strong winds or gusts, and do not operate the machine when there is lightning or heavy rain. • If the machine comes into contact with live wires, keep away from the machine. Personnel on the ground or on the platform must not touch or operate the machine until the power is switched off. • Do not use the machine as a ground wire during welding and polishing operations.

1218RD	
Platform retracted	365 kg(805 lb)
Platform extended - extension deck only	140 kg(309 lb)

Table 2-1

Voltage (Phase to Phase, kV)	Minimum Safe Distance (m/ft)
0-50	3.05 (10)
50-200	4.60 (15)
200-350	6.10 (20)
350 -500	7.62 (25)
500 -750	10.67 (35)
750 -1000	13.725 (45)

TIPPING HAZARDS AND RATED LOAD

Max platform capacity (rated load):

Table 2-2

1018RD	
Platform retracted	450 kg(992 lb)
Platform extended - extension deck only	140 kg(309 lb)

⚠ WARNING



TIPPING HAZARDS

- Personnel, equipment and materials on the platform must not exceed the maximum platform capacity.
- Only raise or extend the platform when the machine is on solid, level ground.
- Do not use the tilt alarm as a level indicator. The tilt alarm on the platform will sound only if the machine is heavily tilted. If the tilt alarm sounds:
 - Be very careful to lower the platform. Transfer the machine to solid, level ground. Do not change the level or limit switch.
- Do not drive faster than 0.48 km/h (0.3 mph) when the platform is raised.
- When the platform is raised, the machine cannot travel on uneven terrain, unstable surfaces or in other dangerous conditions.
- Do not operate the machine during strong winds or gusts, and do not increase the surface area of the platform or load. Increasing the area exposed to the wind will reduce the stability of the machine.
- When the machine is on rough ground, with gravel or other uneven surfaces, or near holes and steep slopes, use caution and reduce the speed.
- Do not push and pull objects outside of the platform. The maximum side force allowed is 400 N(90 lbf).
- Do not change any machine parts that may affect safety and stability.
- Do not replace key parts that affect machine stability with different weights or specifications.
- Do not modify or change moving aerial platforms without the manufacturer's prior written permission.

⚠ WARNING





TIPPING HAZARDS

- On the platform, do not attach an additional device for placing tools or other materials to the guardrail. This will increase the platform weight, surface area and load.
- Do not place on, or fasten to, any overhanging load to any part of this machine.
- Do not place ladders or scaffolding on the platform or any parts of the machine.
- Do not use the machine on a moving or active surface or on a vehicle. Ensure all tires are in good condition, the slotted nuts tightened and the cotter pins complete.
- Do not use a platform to propel machines or other objects.
- Do not let the platform touch nearby objects.
- Do not tie off the platform with rope or other binding materials to nearby objects.
- Do not put a load outside the platform.
- Do not operate the machine when the chassis doors are open.
- When the platform is caught or stuck or when other objects in the vicinity impede its normal movement, do not use the platform controller to lower the platform. If you intend to lower the platform with a ground controller, you must operate it only after all personnel have left the platform.

WORK ENVIRONMENT HAZARDS

 **WARNING**

UNSAFE JOBSITE HAZARDS

- Do not operate the machine on surfaces, edges or potholes that cannot bear the weight of the machine. Raise or extend the platform only when the machine is on firm, flat ground.
- Do not use the tilt alarm as a horizontal indicator. The tilt alarm on the platform will sound only when the machine is heavily tilted.
- If the tilt alarm sounds while lifting the platform, be very careful when lowering the platform. Do not change the level or limit switch.
- Drive speed should not exceed 0.48 km/h (0.3 mph) when the platform rises.
- If the machine can be used outdoors, never operate it during strong winds or gusts. Do not lift the platform when the wind speed

 **WARNING**

UNSAFE JOBSITE HAZARDS



exceeds 12.5 m/s (18 mph). If the wind speed exceeds 12.5 m/s (18 mph) after the platform is lifted, fold the platform and do not continue to operate the machine.

- Never travel on uneven terrain or unstable surfaces or in other dangerous conditions when raising the platform.
- When the machine retracts, be careful and slow down when the machine is moving on uneven terrain, crushed stone, unstable or smooth surfaces, steep slopes and near cave entrances.
- Do not drive or lift the machine on slopes, steps or vaulted surfaces that exceed the maximum climbing capacity of the machine.

Before or during machine operation, check the potential hazards on the jobsite and beware of the environmental limitations, including potentially flammable and explosive gas/dust.

Table 2-3

BEAUFORT NUMBER	METERS/ SECOND	MILE/ HOUR	DESCRIPTION	GROUND CONDITION
0	0 ~ 0.2	0 ~ 0.5	Calm	Calm. Smoke rises vertically.
1	0.3 ~ 1.5	1 ~ 3	Light air	Wind motion visible in smoke.
2	1.6 ~ 3.3	4 ~ 7	Light breeze	Wind felt on exposed skin. Leaves rustle.
3	3.4 ~ 5.4	8 ~ 12	Gentle breeze	Leaves and smaller twigs in constant motion.
4	5.5 ~ 7.9	13 ~ 18	Moderate breeze	Dust and loose paper rise. Small branches begin to move.
5	8.0 ~ 10.7	19 ~ 24	Fresh breeze	Smaller trees sway.
6	10.8 ~ 13.8	25 ~ 31	Strong breeze	Large branches in motion. Flags waving near horizontal. Umbrella use becomes difficult.
7	13.9 ~ 17.1	32 ~ 38	Near gale/moderate gale	Whole trees in motion. Effort needed to walk against the wind.

BEAUFORT NUMBER	METERS/ SECOND	MILE/ HOUR	DESCRIPTION	GROUND CONDITION
8	17.2 ~ 20.7	39 ~ 46	Fresh gale	Twigs broken from trees. Cars veer on road.
9	20.8 ~ 24.4	47 ~ 54	Strong gale	Light structure damage.

NOTICE

Maximum gradeability is suitable for machines with platform retracted.

Gradeability:

1018RD : 35% (19°)

1218RD : 35% (19°)

Gradeability means the maximum allowable tilt angle of the machine when it is on solid ground and the platform is only capable of carrying one person. As the weight of the machine's platform increases, the machine's climbing capacity reduces.

UNSAFE OPERATION HAZARDS

At a minimum, operators must operate and maintain the machine as stated in this manual and in the *Maintenance Manual* in addition to following more stringent industry regulations and workplace rules. Never engage in unsafe machine operation.

⚠ WARNING

UNSAFE OPERATION HAZARDS



- Do not push any object outside the platform. The maximum side force allowed is 400 N(90 lbf).
- Do not change any machine parts that may affect safety and stability.
- Do not replace key parts that affect machine stability with different weights or specifications.
- Do not change or modify moving aerial platforms without the manufacturer's written permission.
- On the platform, do not attach an additional device for placing tools or other materials to the guardrail. This will increase the platform weight, surface area and load.
- Do not put ladders or scaffolding on the platform or any part of this machine.
- Do not use the machine on any mobile or movable surface or vehicle. Ensure all tires are in good condition, the slotted nuts tightened and the cotter pins complete.
- Do not place or attach any suspended load onto any part of the machine.
- Do not use the machine as a crane.
- Do not use the platform to push the machine or other objects.
- Do not allow the platform to touch nearby objects.
- Do not tie the platform onto nearby objects.
- Do not put the load outside the platform.
- When the platform is caught or stuck or when other objects in the vicinity impede its normal movement, do not use the platform controller to lower the platform. If you intend to lower the platform with a ground controller, you must operate it

⚠ WARNING

UNSAFE OPERATION HAZARDS

- only after all personnel have left the platform.
- Do not operate the machine when the chassis door box is open.
- When one or more of the machine's tires are off the ground, evacuate all personnel before attempting to stabilize the equipment. Use a crane, forklift or other suitable apparatus to stabilize the equipment.

FALL HAZARDS

At a minimum, operators must operate and maintain the machine as stated in *Operation Manual* and in the *Maintenance Manual* in addition to following more stringent industry regulations and workplace rules.

⚠ WARNING

FALL HAZARDS











- Each person on the platform must wear harnesses or use safety equipment consistent with government regulations. Fasten the cable to the fixed point of the platform. Never fasten the cable of more than one person to a fixed point on the platform.
- Do not sit, stand or crawl on the guardrails. When on the platform always remain standing on the platform floor.
- Do not climb down from the platform when the platform is elevated.
- Keep the platform floor free of obstacles.
- Do not enter or exit the platform unless the machine is fully in place.
- Close the platform entrance door before operating the machine.
- Do not operate the machine if the handrails are not properly installed and the platform entry door is not closed.

COLLISION HAZARDS

At a minimum, operators must operate and maintain the machine as stated in this manual and in the *Maintenance Manual* in addition to following more stringent industry regulations and workplace rules.

⚠ WARNING

COLLISION HAZARDS

- Pay attention to the field of sight and the presence of blind spots when moving or operating the machine.
- Pay attention to the extended platform when moving the machine.
- Check the work area to avoid ground and overhead obstructions or other possible risks.
- Be sure to exercise caution when using the platform controller and chassis controller. Color-marked directional arrows show the function of travel, lift and steering.
- Users must comply with user, workplace and government rules regarding the use of personal protective equipment (hard hats, safety belts and gloves, etc.).
- Place the machine on level ground or in a secured position before releasing the brakes.
- Only lower the platform when there are no people or obstructions in the area beneath it.
- Limit the speed of travel according to ground conditions, crowding, gradients, the presence and location of personnel and any other factors that may cause collisions.
- Do not operate the machine on any crane or overhead traveling device unless the crane control is locked or precautions have been taken to prevent any potential collision.
- Do not place your hands and arms where they may become crushed or trapped.
- Do not work in or under the platform or near the scissor arms when the safety lever is not in place.
- Maintain good judgment and planning when using the controller on the ground to operate the machine. Maintain proper distance between operator, machine and fixed object.

⚠ WARNING**COLLISION HAZARDS**

- Never operate a machine dangerously or for fun.

CRUSH HAZARDS

A potential crush hazard exists during movement of the machine. Always keep body parts and clothing a safe distance from the machine during machine operation.

⚠ WARNING**CRUSH HAZARDS**

- Do not place your hands and arms where they may become crushed or trapped.
- Do not work in or under the platform or near the scissor arms when the safety lever is not in place.
- Maintain good judgment and planning when using the controller on the ground to operate the machine. Maintain proper distance between operator, machine and fixed object.

EXPLOSION AND FIRE HAZARDS**⚠ WARNING****EXPLOSION AND FIRE HAZARDS**

- Do not use the machine or charge the battery in hazardous or potentially flammable or explosive atmosphere.
- Do not add fuel while the engine is running.
- Do not spray ether onto the engine equipped with glow plug.

DAMAGED MACHINE HAZARDS**NOTICE**

To avoid machine damage, follow all operation and maintenance requirements in this manual and the Maintenance Manual.

⚠ WARNING**UNSAFE OPERATION HAZARDS**

- Do not use the machine if it is damaged or not in proper operating condition.
- Thoroughly inspect and test for all functions of the machine before use. Immediately mark and stop damaged or faulty machines.
- Ensure that all maintenance operations have been performed in accordance with this manual and the corresponding *Maintenance Manual*.
- Make sure all labels are in place and are legible.
- Ensure that the *Operation Manual* and *Maintenance Manual* are sound, easy to read and stored in the storage compartment on the platform.

BODILY INJURY HAZARDS

Always follow all operation and maintenance requirements in this manual and the .

⚠ WARNING**UNSAFE OPERATION HAZARD**



Do not operate the machine when there are oil spills/leaks. Oil spills or leaks in hydraulic fluids may penetrate and burn the skin.

NOTE: The operator must carry out maintenance during the pre-operation inspection only. During operation, keep the left and right doors of the chassis closed and locked. Only trained service personnel can open the left and right doors to repair the machine.

BATTERY HAZARDS

⚠ WARNING

FIRE AND EXPLOSION HAZARD

- Batteries contain sulfuric acid and generate explosive mixtures of hydrogen and oxygen gases. Keep any device that may cause sparks or flames (including cigarettes/smoking materials) away from the battery to prevent explosion.
- Do not touch the battery terminals or cable clips with tools that may cause sparks.

⚠ WARNING

BATTERY HAZARD



- Be sure to read and follow the recommendations given by the battery manufacturer regarding how to correctly use and maintain the battery.
- Always wear protective glasses or goggles and protective clothing when working with batteries. Remove all rings, watches and other accessories.

⚠ WARNING

CHEMICAL BURN HAZARD



Avoid spilling or contacting battery acid with unprotected skin. Seek medical attention immediately if battery acid contacts skin.

⚠ WARNING

BATTERY HAZARD



- Only the properly trained personnel authorized by the workplace are allowed to remove the battery from the machine.
- Before replacing the battery, be sure to identify the appropriate number of personnel and the lifting method.
- During the assembling or disassembling process, never use the battery in a forcible manner, and never allow the battery to fall off.
- Never directly short-circuit the battery outputs with electrical cords.
- Should the battery acid spill out, use bicarbonate (baking soda) mixed with water to neutralize the acid.
- Never store the battery in water or humid atmosphere.
- Daily check the battery cable for damage, and replace any damaged parts before operating the machine.

⚠ WARNING**LITHIUM BATTERY HAZARD**

- Only use the dedicated charger to charge the battery.
- Do not allow lens, needles or other sharp objects to contact with the battery, otherwise the battery membrane will easily get damaged.
- Do not immerse the battery into the sea or water for an extended period of time.
- Do not use the machine with the battery close to a heat source (- fire, heater, etc).
- Do not use the battery with the positive or negative terminals installed inversely.
- Do not directly connect the battery to a power outlet .
- Do not throw the battery into a fire or heater,

NOTICE

After charging the battery, be sure that:

- *The battery cable connections are free of corrosion.*
- *The battery hold-down and cable connections are secured.*

Adding terminal protection and anti-corrosion sealants will help reduce corrosion of the battery terminals and cables.

HYDRAULIC SYSTEMS HAZARD**⚠ WARNING****BURN AND HIGH PRESSURE HAZARD**

- Hydraulic systems are hot. **DO NOT TOUCH!** Serious personal injury may result from hot hydraulic fluid.
- When work on the hydraulic system is completed, thoroughly clean any spilled oil from the machine. Do not spill any hydraulic fluid on the ground. Clean any hydraulic fluid from your skin as soon as you have completed performing maintenance and repairs. Dispose of used fluid as required by law.
- Never inspect for hydraulic leaks with bare hands or other exposed body parts. As a minimum, wear leather gloves and use cardboard or wood to inspect for leaks. If leaks are present, relieve pressure to allow system to cool prior to servicing. If injured by escaping hydraulic fluid, contact a physician immediately. Serious complications may arise if not treated immediately.

WELDING AND POLISHING REQUIREMENTS

Before welding, grinding and polishing operations, always ensure you read and understand all operation and maintenance requirements in this manual and the *Maintenance Manual*.

⚠ WARNING**WELDING HAZARDS**

- Comply with the welder manufacturer's recommendations for procedures concerning proper use of the welder.
- Welding leads or cables may only be connected after turning off the power unit.
- Carry out welding operations only after the welding cable has been correctly connected.
- Do not use the machine as a ground wire during welding operation.
- At all times, make sure that the power tools are completely stored in the working platform. Do not hang the power tools on the railing of the working platform or the work area outside the working platform, or hang the power tools directly by the wire.

Before performing welding, grinding and polishing work, welders must seek permission of the responsible department at the workplace.

AFTER USING THE MACHINE

1. Choose a safe parking location that is on sturdy, level ground and that is free of obstructions. Avoid areas with heavy traffic.
2. Lower the platform.
3. Turn the emergency stop switch of the ground controller to the "OFF" position
4. Turn the key switch to the "OFF" position and remove the key to avoid unauthorized use of the machine.
5. Block the wheels with the wheel wedges.
6. Charge the battery.

NOTICE

After using the machine, the power off switch must be disconnected.

This Page Intentionally Left Blank

3 SYSTEM DESCRIPTIONS

POWER SYSTEM

The machine is powered by a diesel engine (Kubota D1105-E4B-EU-X1), which drives a gear pump (16cc/r) splined with the output shaft of the engine to provide power for the system.

HYDRAULIC SYSTEM

All functions of the machine are driven by hydraulic system. The entire hydraulic system can be divided into two sections: one for such functions as lift/lower, steer, outrigger extend/retract/oscillate, the other for the drive function.

When the engine operates, the hydraulic pump diverts the pressure oil to each function manifold, on which is installed with directional valves and flow regulator valves for completing various functions and regulating the speed. Relief valve is also fitted on the manifold to prevent the system from getting overloaded.

ELECTRICAL SYSTEM

The system incorporates a 12V lead-acid battery to start the engine, and to serve as a power source for the entire electrical system. The battery is charged by the engine-driven DC generator. Circuit breakers are used to protect the control system.

MACHINE CONTROL

The machine functions are controlled by two controllers, one installed on the left side of turntable to control the boom functions, the other on the platform to control the machine drive and platform lift/lower functions. The controller communicates signals through a high-speed data bus.

SAFETY MEASURES

A wide range of angle sensors and limit switches are used to provide signals for the controller. The level sensor measures the chassis inclination in X and Y

axes. When the inclined angle exceeds 2° in X axis or 3° in Y axis, the alarm will sound and such functions as lift, drive and steer are restricted.

The travel switches for outriggers are intended to determine whether the outriggers are extended in place. In the event of the outrigger cylinder coming in contact with the ground, the automatic leveling function will be activated to keep the machine level.

The oscillate travel switch is intended to detect the outrigger oscillating function. When the travel switch is not working properly, the alarm will be triggered.

The weighing system is intended to ensure the load on the platform is within its limits. When the load on the platform exceeds the platform capacity (see [Machine Specifications, page 1-1](#)), or the platform elevated height is greater than 1m or 10% of the max platform height (whichever is larger), the overload LED will light and the alarm will sound, the platform is restricted from further movement, and allows no operation until the excessive weight is removed from the platform.

This Page Intentionally Left Blank

4 SERVICE AND GUIDELINES

MACHINE PREPARATION, INSPECTION AND MAINTENANCE

GENERAL

This section provides safety and necessary information for the machine operators. For maximum service life and safe operation, ensure that all necessary inspections and maintenance have been completed before placing the machine into service.

Machine positions

Operating/raised position :

The machine comes in operating/raised position when the platform is raised until the down limit switch disengages.

Platform heights at which the down limit switch disengages (height from ground to platform floor) :

1018RD : 2.7 ~ 3.3m (8.6ft ~ 10.8ft)

1218RD : 2.7 ~ 3.3m (8.6ft ~ 10.8ft)

Stowed position :

The machine comes in stowed position when fully retracted.

PREPARATION, INSPECTION AND MAINTENANCE

It is important to establish and conform to a comprehensive inspection and preventive maintenance program. This manual outlines the scheduled machine inspections and maintenance recommended by Hunan Sinoboom Intelligent Co., Ltd., Consult your national, regional or local regulations for aerial work platforms. The frequency of inspections and maintenance must be increased as environment, severity and frequency of usage requires.

QUALIFIED SINOBOOM EQUIPMENT MECHANIC

Qualified Sinoboom equipment mechanic is a person recognized by Sinoboom as one who, by possession of a recognized degree, certificate, training, has successfully demonstrated the ability and proficiency to service, repair and maintain the subject Sinoboom product model.

PRE-OPERATION INSPECTION

Prior to daily use or work shift of operators, the user or operator should perform a pre-operation inspection. Refer to the *Operation Manual* for the complete procedure for the pre-operation inspection. The *Operation Manual* must be entirely read and understood before performing the pre-operation inspection.

PRE-DELIVERY INSPECTION AND FREQUENT INSPECTION

The pre-delivery inspection shall be performed by qualified Sinoboom equipment mechanic. The pre-delivery inspection and the frequent inspection are performed in the same manner, but at different times. The pre-delivery inspection shall be performed before each sale, lease or rental delivery. The frequent inspection shall be accomplished for each machine in service for 3 months or 150 hours (whichever comes first); out of service for a period of more than 3 months; or when purchased used. The frequency of this inspection must be increased as environment, severity and frequency of usage requires.

Reference the *Prepare the Work Record before Delivery* and *Repair & Inspection Report* for items requiring inspection. Reference the *Inspection Procedures* in appropriate areas of this manual to perform the inspection and maintenance procedures.

ANNUAL MACHINE INSPECTION

The annual machine inspection must be performed on an annual basis, no later than 13 months from the date of the prior annual machine inspection. Hunan Sinoboom Intelligent Equipment Co., Ltd. recommends this task be performed by a factory-trained service technician, a person recognized by Sinoboom as one who, by possession of a recognized degree, certificate, training, has successfully demonstrated the ability and proficiency to service, repair and maintain the subject Sinoboom product model.

Reference the *Repair & Inspection Report* for items requiring inspection. Reference the *Inspection Procedures* in appropriate areas of this manual to perform the inspection and maintenance procedures.

For the purpose of receiving the safety-related bulletins, it is important that Hunan Sinoboom Intelligent Equipment Co., Ltd. has updated ownership information for each machine. When performing each

annual machine inspection, notify Hunan Sinoboom Intelligent Equipment Co., Ltd. of the current machine ownership information.

PREVENTIVE MAINTENANCE

The preventive maintenance must be performed by a qualified Sinoboom equipment mechanic.

Reference the *Repair & Inspection Report* and *Maintenance Schedule* in this manual for the inspection items and intervals. Reference the *Inspection Procedures* in appropriate areas of this manual to perform the inspection and maintenance procedures.

Table 4-1

Type	Frequency	Primary Responsibility	Service Qualification	Reference
Pre-operation Inspection	Prior to use each day; or at each operator change.	User or operator	User or operator	Operation Manual
Pre-delivery Inspection	Prior to each sale, lease or rental delivery.	Owner, dealer or user	Qualified Sinoboom mechanic	Maintenance Manual, Pre-delivery Preparation Form, and Maintenance Inspection Report
Frequent Inspection	In service for 3 months or 150 hours, whichever comes first; or out of service for a period of more than 3 months; or purchased used.	Owner, dealer or user	Qualified Sinoboom mechanic	Maintenance Manual and Maintenance Inspection Report
Annual Machine Inspection	Annually, no later than 13 months from the date of the prior annual inspection.	Owner, dealer or user	Factory-trained service technician	Maintenance Manual, Pre-delivery Preparation Form, and Maintenance Inspection Report
Preventive Maintenance	At intervals as specified in the Maintenance Manual.	Owner, dealer or user	Qualified Sinoboom mechanic	Maintenance Manual, Maintenance Inspection Report, and Maintenance Schedule

MAINTENANCE AND SERVICING PRECAUTIONS

GENERAL

This section assists you in the use and application of the maintenance and servicing procedures contained in this manual.

SAFETY AND WORKMANSHIP

Your safety, and that of others, is the first consideration when engaging in the maintenance of equipment. Never attempt to move heavy parts without the aid of a mechanical device. Do not allow heavy objects to rest in an unstable position. When raising a portion of the equipment, ensure that adequate support is provided.

CLEANLINESS

1. The most important single item in preserving the service life of a machine is to keep dirt and foreign materials out of the vital components. Precautions have been taken to safeguard against this. Shields,

covers, seals and filters are provided to keep air, fuel and oil supplies clean; however, these items must be maintained on a scheduled basis to function properly.

2. When air, fuel or oil lines are disconnected, clean the adjacent areas as well as the openings and fittings. As soon as a component or line is disconnected, cap or cover all openings to prevent entry of foreign matter.
3. Clean and inspect all parts during servicing and maintenance, and assure that all passages and openings are unobstructed. Cover all parts to keep them clean. Be sure all parts are clean before they are installed. New parts should remain in their containers until they are ready to be used.

COMPONENT REMOVAL AND INSTALLATION

1. Use adjustable lifting devices, whenever possible, if mechanical assistance is required. All slings (- chains, cables, etc.) should be parallel to each other and as near perpendicular as possible to top of part being lifted.
2. Should it be necessary to remove a component on an angle, keep in mind that the capacity of an eyebolt or similar bracket lessens, as the angle

between the supporting structure and the component becomes less than 90 degrees.

3. If a part resists removal, check to see whether all nuts, bolts, cables, brackets, wiring, etc, have been removed and that no adjacent parts are interfacing.

COMPONENT DISASSEMBLY AND ASSEMBLY

When disassembling or reassembling a component, complete the procedural steps in sequence. Do not partially disassemble or assemble one part, then start on another. Always recheck your work to assure that nothing has been overlooked. Do not make any adjustments, other than those recommended, without obtaining proper approval.

PRESSURE-FIT PARTS

When assembling pressure-fit part, use a molybdenum disulfide base compound or equivalent to lubricate the mating surface.

BEARINGS

1. When a bearing is removed, cover it to keep out dirt and abrasives. Clean bearings in nonflammable cleaning solvent and allow to drip dry. Compressed air can be used but do not spin the bearing.
2. Discard bearings if the races and balls (or rollers) are pitted, scored, or burned.
3. If bearing is found to be serviceable, apply a light coat of oil and wrap it in clean (waxed) paper. Do not unwrap reusable or new bearings until they are ready to install.
4. Lubricate new or used serviceable bearings before installation. When pressing a bearing into a retainer or bore, apply pressure to the outer race. If the bearing is to be installed on a shaft, apply pressure to the inner race.

GASKETS

Check that holes in gaskets align with openings in the mating parts. If it becomes necessary to hand-fabricate a gasket, use gasket material or stock of equivalent material and thickness. Be sure to cut holes in the right location, as blank gaskets can cause serious system damage.

BOLT USAGE AND TORQUE APPLICATION

NOTICE

Self-locking fasteners, such as nylon insert and thread deforming locknuts, are not intended to be reinstalled after removal.

1. Always use new replacement hardware when installing locking fasteners. Use bolts of proper length. A bolt which is too long will bottom before the head is tight against its related part. If a bolt is too short, there will not be enough thread area to engage and hold the part properly. When replacing parts, use only those having the same specifications of the original, or one which is equivalent.
2. Unless specific torque requirements are given within the text, standard torque values should be used on heat-treated bolts, studs, and steel nuts, in accordance with recommended shop practices. (See [Fastener Torque Specifications, page 1-9](#))

HYDRAULIC LINES AND ELECTRICAL WIRING

Clearly mark or tag hydraulic lines and electrical wiring, as well as as their receptacles, when disconnecting or removing them from the unit. This will assure that they are correctly reinstalled.

HYDRAULIC SYSTEM

1. The primary enemy of a hydraulic system is contamination. Contaminants enter the system by various means, e.g., using inadequate hydraulic oil, allowing moisture, grease, filings, sealing components, sand, etc., to enter when performing maintenance.
2. Keep the system clean. If evidence of metal or rubber particles are found in the hydraulic system, drain and flush the entire system.
3. Disassemble or reassemble parts on clean work surface. Clean all metal parts with non-flammable cleaning solvent. Lubricate components, as required, to aid assembly.

LUBRICATION

Service applicable components with the amount, type, and grade of lubricant recommended in this manual, at the specified intervals. When recommended lubricants are not available, consult your local supplier for an

equivalent that meets or exceeds the specifications listed.

BATTERY

Clean battery, using a non-metallic brush and a solution of baking soda and water. Rinse with clean water. After cleaning, thoroughly dry battery and coat terminals with an anti-corrosion compound.

PINS AND COMPOSITE BEARING

1. Pinned joints should be disassembled and inspected if the following occurs :
 - Excessive sloppiness in joints.
 - Noise originating from the joint during operation.
2. The composite bearing should be replaced if the following occurs :
 - Frayed or separated fibers on the liner surface.
 - Cracked or damaged liner backing.
 - Bearing that have moved or spun in their housing.
 - Debris embedded in liner surface.
3. Pins should be replaced if any of the following is observed (pin should be properly cleaned prior to inspection) :
 - Detectable wear in the bearing area.
 - Flaking, peeling, scoring, or scratches on the pin surface.
 - Rusting of the pin in the bearing area.
4. Reassembly of pins and composite bearing:
 - Housing should be blown out to remove all dirt and debris. Bearings and bearing housings must be free of all contamination.
 - Bearing/pins should be cleaned with a solvent to remove all grease and oil. The composite bearing is a dry joint and needs no lubricating.
 - Pins should be inspected to ensure it is free of burrs, nicks, and scratches which would damage the bearing during installation and operation.

APPLICATION OF INSULATING SILICONE GREASE TO ELECTRICAL CONNECTIONS

Insulating silicone grease should be applied to all electrical connections for the purpose of :

- Avoiding oxidization of the mechanical joints between the male pins and female pins.
- Avoiding electrical failure due to low conductivity between the pins in humid environment.

The following procedure should be observed to apply the insulating silicone grease to the electrical connections. The procedure applies to all plugged connections outside of the power distribution box. The silicone grease is not suitable for the connectors with enclosed outer surface.

1. Prior to the machine assembling, apply silicone grease around the male pins and female pins inside the connectors to prevent oxidization. An injector may be used for the convenience of operation.

NOTICE

The oxidization exceeding a certain period will increase the resistance of the connector and eventually lead to electrical failure.

2. Silicone grease should be applied to each electrical cord that is exposed at the outside of the connector to prevent short circuit. Besides, the joint between the male and female connectors should also be applied with silicone grease. Other joints that may allow entry of water into the connectors, like the area around the anti-pull buckle, should be properly sealed as well.

NOTICE

Since the electrical conductivity of cleaning solvent is superior to that of water, it is mostly likely that this will occur when using pressure cleaning method to clean the machine.

3. Silicone grease should be applied to each contact of the connectors for battery case and charger.

NOTICE

The setting type sealant can be used to avoid short circuit and keep the connections tidy, but it will make the future removal of pins more difficult.

This Page Intentionally Left Blank

5 MAINTENANCE

This section provides detailed procedures for regular maintenance inspections.

 **WARNING**

UNSAFE OPERATION HAZARD



Failure to follow the proper maintenance may result in death, serious injury or damage to the machine.

Follow these general rules:

- Professionally trained, qualified personnel must conduct routine maintenance inspections on this machine.
- Daily routine maintenance inspections must occur during normal operation of the machine. Maintenance inspectors must carry out inspection and maintenance according to the repair & inspection report and must complete the repair & inspection report.
- Regular maintenance inspections must occur by operators and at quarterly, biannual and annual intervals by qualified, trained personnel. Qualified, trained personnel must check and maintain the machine according to the repair & inspection report and must complete the repair & inspection report.
- Immediately remove a damaged or malfunctioning machine, mark it and stop using it.
- Repair any damaged or malfunctioning machine before operating it.
- Keep all machine inspection records for at least 10 years or until the machine is no longer in use or as required by machine owner/company/custodian.
- Conduct a quarterly inspection on machines that have been out of service for a period lasting longer than three months.
- While maintaining the machine, replace any parts on the machine using the same parts or the same parts of the original machine.
- Unless otherwise specified, perform all maintenance procedures according to the following terms and conditions:
 - Park the machine on flat, level, firm ground.
 - Keep the machine in the stowed position.

- Ensure the key switch of the ground controller is in the OFF position and remove the key to prevent unauthorized use of the machine.
- Place the red emergency stop button on the platform control box and ground controller in the OFF position to avoid accidental start-up of the operating system.
- Disconnect main power switch.
- Disconnect all DC power from the machine.
- Lock all wheels to prevent movement of the machine.
- Before releasing or removing the hydraulic components, release the hydraulic oil pressure in the hydraulic pipeline.

CONDUCTING A PRE-DELIVERY INSPECTION

When the machine owner/company changes, in addition to conducting a pre-delivery inspection, the corresponding inspection shall be carried out according to the maintenance schedule requirement and repair & inspection report. When conducting a pre-delivery inspection, comply with the following requirements:

1. It is the responsibility of the machine owner/company to perform a pre-delivery inspection.
2. Follow this procedure each time before delivery. Performing a pre-delivery inspection could reveal potential problems with the machine before you begin putting the machine into service.
3. Never use a damaged or malfunctioning machine. Tag the machine and do not use it.
4. Only professionally trained, qualified personnel may repair the machine and must follow the procedures as stated in *operation manual* and *maintenance manual*.
5. A competent operator must conduct daily maintenance on this machine as stated in *operation manual* and *maintenance manual*.

Before delivering the machine, complete the following record using these instructions:

1. Prepare the machine before delivery, which includes performing a pre-delivery inspection, following maintenance procedures and performing functional inspections.

- Use the following table to note the results. After each section is complete, mark the appropriate box.
- Record the inspection results. If any inspection results are "NO", the machine must be stopped and

re-inspected after repair is completed and marked in the box marked "inspection".

Table 5-1

PREPARE THE WORK RECORD BEFORE DELIVERY			
Model			
Serial No.			
Inspection Item	YES/Machine is in Good Condition	NO/Machine Has Damage or Malfunction	REPAIRED/Machine Has Been Repaired
Pre-operational Inspection			
Maintenance Procedure			
Functional Inspection			
Machine Buyer/ Renter			
Inspector Signature			
Inspector Title			
Inspector Company			

FOLLOWING A MAINTENANCE SCHEDULE

Regular maintenance inspections must occur daily, quarterly, biannually (every 6 months) and annually. Use the table to help you adhere to a routine maintenance schedule.

Table 5-2

INSPECTION INTERVAL	INSPECTION PROCEDURES
Every day or every 8 hours	A
Every quarter or every 250 hours	A+B
Every half a year or every 500 hours	A+B+C
Every year or every 1000 hours	A+B+C+D

COMPLETING A REPAIR & INSPECTION REPORT

- Divide the Repair & Inspection Report into four sections (A, B, C and D) according to the time requirements of the maintenance schedule and the maintenance procedure requirements.
- The Repair & Inspection Report shall include the inspection table of each regular inspection.
- Duplicate the Repair & Inspection Report for each inspection. Store the completed tables for 10 years or until the machine is no longer in use or as required by machine owner/company/custodian.
- Use the following table to note the results. After each section is complete, mark the appropriate box.
- Record the inspection results. If any inspection results are "NO", the machine must be stopped and re-inspected after repair is completed and marked in the box marked "inspection". Select the appropriate inspection procedure based on the inspection type.

REPAIR & INSPECTION REPORT	
Model	
Serial No.	

REPAIR & INSPECTION REPORT				
Checklist A Procedures				
Items	YES/Machine is in Good Condition	NO/Machine Has Damage or Malfunction	REPAIRED/ Machine Has Been Repaired	Problem Description
A-1 Inspect All Manuals				
A-2 Inspect All Decals				
A-3 Inspect Damaged, Loose or Lost Parts				
A-4 Inspect Hydraulic Oil Level				
A-5 Inspect Hydraulic Oil Leakage				
A-6 Inspect Fuel Level				
A-7 Inspect Fuel Leakage				
A-8 Inspect Engine Oil Level				
A-9 Inspect Coolant Level				
A-10 Inspect Engine Intake System				
A-11 Inspect Engine Belt				
A-12 Inspect Fuel Filter				
A-13 Inspect Cooling Fan				
A-14 Functional Tests				
A-15 Perform Maintenance after 30 Days				
Checklist B Procedures				
Items	YES/Machine is in Good Condition	NO/Machine Has Damage or Malfunction	REPAIRED/ Machine Has Been Repaired	Problem Description
B-1 Inspect Electrical Wiring				
B-2 Inspect Rim ,Tire and Fasteners				
B-3 Inspect Hydraulic Oil				
B-4 Inspect Cooling System				
B-5 Replace Fuel filter				

REPAIR & INSPECTION REPORT				
B-6 Inspect Air filter of Hydraulic Tank				
B-7 Replace High-Pressure Filter Element				
B-8 Replace Engine Air Filter Element				
B-9 Inspect the Battery				
B-10 Inspect Engine Exhaust System				
B-11 Inspect Drive Reducer Oil Level				
B-12 Test Oscillate Outriggers				
B-13 Test Drive Speed				
B-14 Test Tilt Protection System				
B-15 Test Brake Distance				
Checklist C Procedures				
Items	YES/Machine is in Good Condition	NO/Machine Has Damage or Malfunction	REPAIRED/ Machine Has Been Repaired	Problem Description
C-1 Replace Fuel Filter Element				
C-2 Replace Engine Oil				
C-3 Replace Engine Oil Filter				
C-4 Test Weighing System				
C-5 Test Secondary Lowering				
Checklist D Procedures				
Items	YES/Machine is in Good Condition	NO/Machine Has Damage or Malfunction	REPAIRED/ Machine Has Been Repaired	Problem Description
D-1 Replace Drive Reducer Gear Oil				
D-2 Inspect Scissor Arm Sliders				
D-3 Replace Hydraulic Oil				
D-4 Replace Hydraulic Tank Suction Filter				

REPAIR & INSPECTION REPORT				
D-5 Inspect Scissor Arm Bearing				
User				
Inspector Signature				
Inspector Date				
Inspector Title				
Inspector Company				

CHECKLIST A PROCEDURES

A-1 Inspect All Manuals

Storing the *Operation Manual* and the *Maintenance Manual* in the appropriate place is important for the safe operation of the machine. The manuals must be stored in the manual storage container on the platform. Illegible or damaged manuals cannot provide necessary safety and operation information for safe operation.

- Inspect and confirm that the manual storage container is placed on the appropriate position of the platform.
- Inspect and confirm that the *Operation Manual* and the *Maintenance Manual* are stored in the manual storage container on the platform.
- Inspect the pages of the manuals and confirm that they are legible and intact.
- Inspect the pages of the manuals and confirm that they are legible and intact.

NOTICE
<i>If needing to replace the manuals, contact Hunan Sino-boom Intelligent Equipment Co., Ltd..</i>

A-2 Inspect All Decals

Ensuring that all labels are in good condition is essential for safe operation of the machine. Decals warn operators of the dangers they may encounter during operations, and they provide users with operational and maintenance information. Illegible decals do not properly guide operators, which can lead to unsafe operations.

- Refer to the decal instructions in the *Operation Manual* and use the decals list and graphic to determine the correct placement of the decal.
- Check whether all decals are legible and damaged. Replace damaged and illegible decals before operating the machine.

NOTICE
<i>If needing to replace the decals, contact Hunan Sino-boom Intelligent Equipment Co., Ltd..</i>

A-3 Inspect Damaged, Loose or Lost Parts

Check the machine for any damaged, improperly installed, loose or missing parts and unauthorized changes:

- Electrical components, wiring and cables
- Hydraulic hoses, fittings, cylinders and counterbalance valves
- Drive motors
- Wear pads
- Tires and wheels
- Limit switches, alarms and horn
- Beacons and indicator lights (if equipped)
- Bolts, nuts and other fasteners
- Brake releasing
- Safety arm
- Platform extension
- Scissor arm pins and fasteners
- Platform extension
- Scissor arm pins and fasteners

- Platform joystick
- Outriggers (if equipped)
- Fuel tank, hydraulic tank
- Engine and associated parts
- Platform entry gate
- Generator (if equipped)

Table 5-3

CUSTOMER REQUIREMENTS	HYDRAULIC OIL MARK
Normal-temperature region 0°C to 40°C (32°F to 104°F)	L-HM46
Cold region -25°C to 25°C (-13°F to 77°F)	L-HV32
High-temperature region greater than 40°C (104°F)	L-HM68
Extremely cold region less than -30°C (-22°F)	Special programmes need to be identified.

NOTICE

If any part is found damaged, missing, or improperly installed, please immediately replace with a new one and install correctly; if any fastener is found detached or loose, please tighten immediately.

A-4 Inspect Hydraulic Oil Level

Ensuring appropriate hydraulic oil level is vital to proper operation of the machine. If too high, the oil will spill out from the oil tank during machine operation, if too low, the oil pump will suction air and damage hydraulic components. Performing daily inspection of the hydraulic oil level will help you determine if a problem exists in the hydraulic system.

Perform the following procedure with the platform retracted:

1. Visually inspect on the hydraulic tank side to be sure the hydraulic oil level is within the marking range of sight gauge.

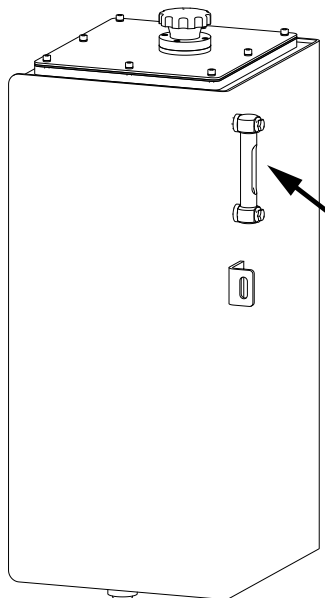

Figure 5-1

2. Ensure the tank body and ports are free of leakage.
3. Add hydraulic oil as needed. Never overfill the tank.

NOTICE

Different hydraulic oils can be added according to customer requirements upon factory delivery, but cannot be mixed.

A-5 Inspect Hydraulic Leakage

Preventing the hydraulic oil from leaking is vital to safe and normal machine operation. If the hydraulic leaks fail to be discovered, it will lead to hazardous situations, reduce the machine performance and damage components.

Inspect the area on or around the following components for hydraulic spillage, dripping or residues:

- Hydraulic tank, filters, hoses and fittings
- Power unit
- Hydraulic cylinders
- Engine
- Hydraulic valves and pumps
- Hydraulic motors
- Areas around the machine

A-6 Inspect Fuel Level

NOTICE

Be sure to shut down the engine before inspection.

Keeping the diesel fuel at an appropriate level is vital to maintaining the engine performance and extending service life. An inappropriate fuel level will bring damage to the engine parts and lead to improper functioning of the machine.

1. Open the rear left door of chassis, and locate the fuel tank.
2. Inspect the fuel level to ensure it is within the marking range of sight gauge.

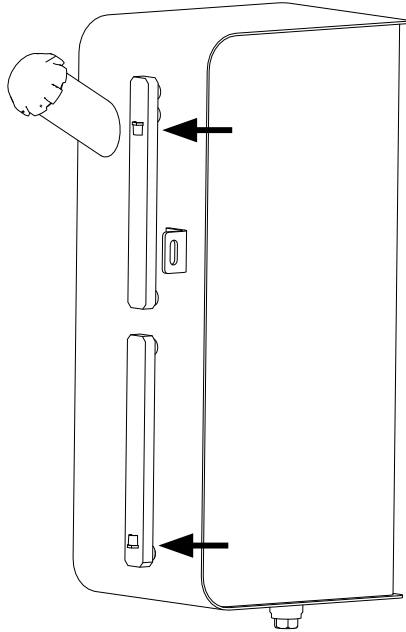

Figure 5-2

3. If the fuel level is below the MIN position, add fuel before work continues.
4. Be sure the fuel tank body and ports are free of leakage.
5. The engine must be off when adding fuel.
6. Open the cap of feul tank, add fuel as need. Never overfill the tank, it is recommended to add 50%–100% of the tank capacity.

Table 5-4

DIESEL GRADE	RECOMMENDED AMBIENT TEMP
5#	Lowest temperature 8°C or higher
0#	Lowest temperature 4°C or higher
-10#	Lowest temperature -5°C or higher
-20#	Lowest temperature -14°C or higher
-35#	Lowest temperature -29°C or higher
-50#	Lowest temperature -44°C or higher

NOTICE

- The diesel has been drained off before delievery, so the customer should add diesel of appropriate grade to suit the operating ambient temperature and the governing emission regulations.
- Do not add mixed diesel of different grades.
- The light fuel may affect the fuel economy or damage the combustion components.
- It is recommended to use the diesel with sulphur content less than 5000ppm.
- It is recommended to use the diesel with min. cetane number of 45 in operating temperatures below 0°C and min.cetane number of 40 in operating temperatures over 0°C. When the cetane number of the diesel in use is less than the recommended number,it may lead to startup failure, instable running or large amount of white smoke.
- The max cloud point and pour point of the diesel must be 6°C less than the lowest operating ambient temperature.

WARNING

EXPLOSION ADN FIRE HAZARD



- Do not mix the diesel with gasoline, alcohol or their mixture.
- Do not add diesel when the engine is running.

WARNING

DAMAGED MACHINE HAZARD



Due to the extremely accurate tolerance match of the diesel injection system, it is critical to keep the fuel clean and free of dirt or water. The dirt or water entering the combustion system can cause severe damage to the fuel pump and injectors.

A-7 Inspect Fuel Leakage

Inspecting fuel leakage is vital to safe and normal machine operation. If a fuel leak is not discovered and

corrected in a timely manner, it will pose hazardous situations.

NOTICE

Shut off the engine before inspection.

WARNING

EXPLOSION AND FIRE HAZARD

- Diesel is an inflammable material. This procedure must be performed outdoors in well-vented area and far away from flames.
- Ensure that a conforming fire extinguisher is readily accessible when performing this inspection procedure.

Inspect for diesel spills, drippings or residues in the following areas :

- Fuel tank, piping and fittings
- Fuel pump and fuel filter
- Fuel injection system

WARNING

EXPLOSION AND FIRE HAZARD

If fuel leakage is discovered, immediately forbid any other personnel from entering the area or operating the machine, and repair the leakage as soon as possible.

A-8 Inspect Engine Oil Level

NOTICE

Turn off the engine before inspection.

The appropriate engine oil level is vital to maintaining the engine performance and extending its service life, otherwise it will damage the engine parts. Through the daily check the inspector can know about the changes on engine oil level which may indicate a system distress with the engine.

1. Turn the ground/platform select switch to ground control.
2. Pull out the emergency stop button at ground controls to ON position.

3. Move the engine preheat switch and idle for 2 minutes.
4. Switch off the engine, and 5 minutes later open the engine cover.
5. Remove the engine dipstick to inspect the engine oil level.
6. The engine oil level should be between the FULL and ADD marks.
7. Add engine oil as needed. Do not overfill. It is recommended to use engine oil equivalent to or higher than CH-4 with viscosity grade of 15W-40.

Table 5-5

VISCOSITY	RECOMMENDED AMBIENT TEMP
0W-30	-35°C ~ 0°C
5W-40	-25°C ~ 30°C
15W-40	-15°C ~ 40°C
20W-50	0°C ~ 50°C

NOTICE

- *The engine oil filled by the factory is generally CH-4 with viscosity 15W-40, suitable for regions with ambient temperature range of 15°C ~ 40°C. If the operating ambient temperature is outside of the range, please change the engine oil as appropriate.*
- *The multi-grade engine oil can provide excellent lubrication under high-temperature operating condition, reduce the sediments, and improve the engine low-temperature start performance and durability. Also, the multi-grade engine oil plays an important role in fulfilling the machine with the emission standards.*
- *Do not mix the engine oils of different grades.*
- *It is recommended that the sulphated ash content not exceed 1%, otherwise it will damage the air valve or piston, and lead to excessive consumption of engine oil.*
- *The use of high-quality engine oil in conjunction with suitable oil filter and change interval is very critical to maintaining engine performance and extending service life. If the oil or oil filter is not changed as recommended, there will be sediments, contaminants or wear incurred which will shorten the engine service life.*

A-9 Inspect Coolant Level

The appropriate coolant level is vital to maintaining the engine performance and extending its service life, otherwise it will damage the engine parts. Through the daily check the inspector can know about the changes on coolant level which may indicate a system distress with the engine.

WARNING

BURN AND EJECTION HAZARDS

Before inspecting the coolant level, allow the coolant to cool down to room temperature, and slowly open the cover to release the pressure.

NOTICE

Turn off the engine before inspection.

1. Turn off the engine, and open the right chassis cover.
2. Open the cover of coolant box over the radiator to inspect the coolant level.

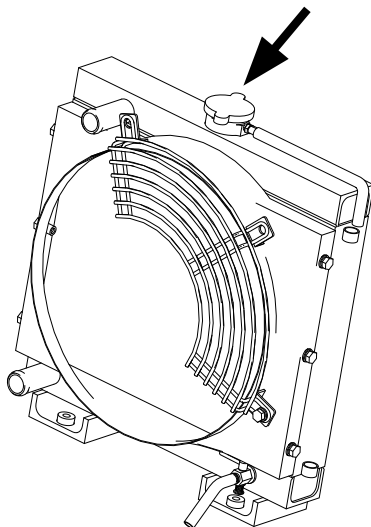

Figure 5-3

3. The coolant level should be at the filler port of the coolant box.
4. Add coolant as needed. Do not overfill. It is recommended to choose the -18°C ready-mix

coolant or the ethylene glycol(ethylene and propene) in ratio mix with water. The water quality must meet the requirements as listed in the table below.

Table 5-6

COOLANT TYPE	RECOMMENDED AMBIENT TEMP
-18°C ready-mix coolant	-18°C or higher
-37°C ready-mix coolant	-37°C or higher
50% ethylene glycol and 50% water mixed coolant	-32°C ~ 0°C
60% ethylene glycol and 40% water mixed coolant	-54°C ~ -32°C

NOTICE

- Do not apply sealing additive to the cooling system, otherwise it will cause blockage to the low-fludity area, radiator and engine oil cooler, or damage the water pump sealing.*
- Do not apply soluable engine oil to the cooling system, otherwise it will corrode the brass and copper, damage the surface of heat exchanger, sealings and hose.*
- The water added into the coolant must meet the requirements of calcium and magnesium less than 170ppm, chloride less than 40 ppm and sulphur less than 100ppm. Excessive calcium and magnesium can lead to scale formation, and excessive chloride and sulfate can corrode the cooling system.*

A-10 Inspect Engine Intake System

Inspecting the engine intake system is vital to good engine performance and extending service life.

NOTICE

Shut off the engine before inspection.

1. Inspect whether the engine intake tube is damaged or extruded flat, or getting loose. If such conditions occur, the dust or debris may enter the engine.
2. Tighten or replace parts, if needed, to assure the intake system free from leakage.

NOTICE

Even if a tiny amount of dust or debris gets inside the engine, it will result in severe wear of piston ring and increased exhaust. Be sure to keep the intake system clean and free of leakage.

A-11 Inspect Engine Belt

Maintaining the engine belt in good condition is vital to good machine performance and service life. The machine should not continue operation with the engine belt being loose or deficient, or it will result in component damage.

NOTICE

Shut off the engine before inspection.

Inspect the engine belt for :

- Crack or breakage
- Wear or misalignment
- Peeling-off
- Glazing or hardening
- Improper tensioning (press at the middle position of the mostly extended belt between the pulleys to check the tensioning condition, the press-down of belt should not exceed 13mm [0.5 in.])

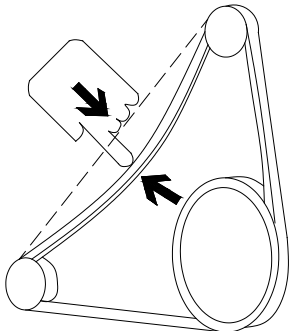

Figure 5-4

Replace the engine belt immediately if the above conditions occur.

NOTICE

The engine manufacturer recommends the drive belt not be applied with belt oil or anti-slipping agent.

A-12 Inspect Fuel Filter

NOTICE

Shut off the engine before inspection.

Inspecting the fuel filter is vital to proper functioning of engine. Failure to perform this inspection procedure will result in engine working improperly or component damage.

WARNING

EXPLOSION AND FIRE HAZARD



- Diesel is an inflammable material. This procedure must be performed outdoors in well-vented area and far away from flames.
- Ensure that a conforming fire extinguisher is readily accessible when performing this inspection procedure.

1. Open the engine cover.
2. Locate the fuel filter.

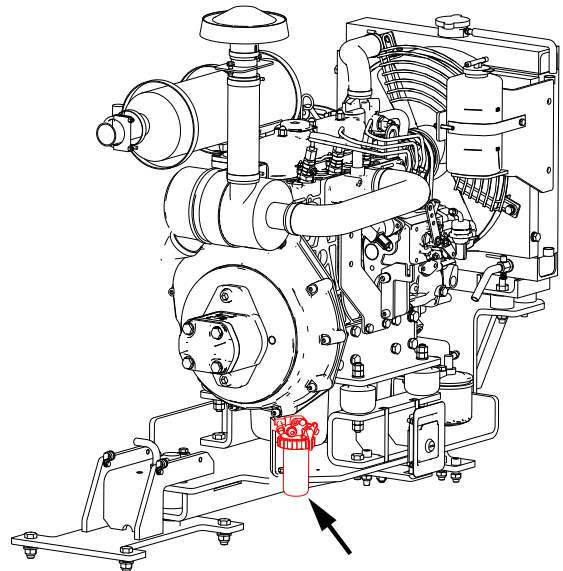

Figure 5-5

3. Loosen the plug of drain valve at the bottom, and drain the water into a suitable vessel until the fuel flows out.

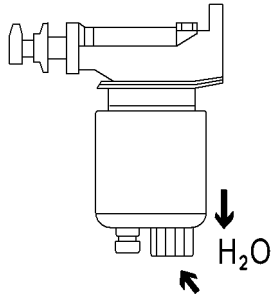

Figure 5-6

4. Tighten the valve plug.
5. Clean up the fuel spill.
6. Start the engine from the ground controller and inspect the fuel filter for leakage.

A-13 Inspect Cooling Fan

Inspecting cooling fan is vital to normal functioning of engine and extending service life.

NOTICE

Shut off the engine before inspection.

1. Open the engine cover.
2. Locate the cooling fan of engine.
3. Inspect the cooling fan for :

- Cracks
 - Tilting or loosening
 - Abrasion
4. Please replace immediately if any of the above conditions occurs.

A-14 Functional Tests

Testing each machine function is vital to safe machine operation. If any function operates improperly, it will pose dangers to safe operation. Ensure any function operates smoothly and reliably, without shaking, sharp or unusual noise.

⚠ WARNING

UNSAFE OPERATION HAZARD

Be sure to observe the instructions and safety rules noted in this manual and *Operation Manual*, otherwise it may lead to death or severe injury.

For the specific procedure for function tests, please reference the Pre-operation Function Test section in *Operation Manual*. Before performing the function test, ensure that the safety rules in the operation manual are fully read and understood.

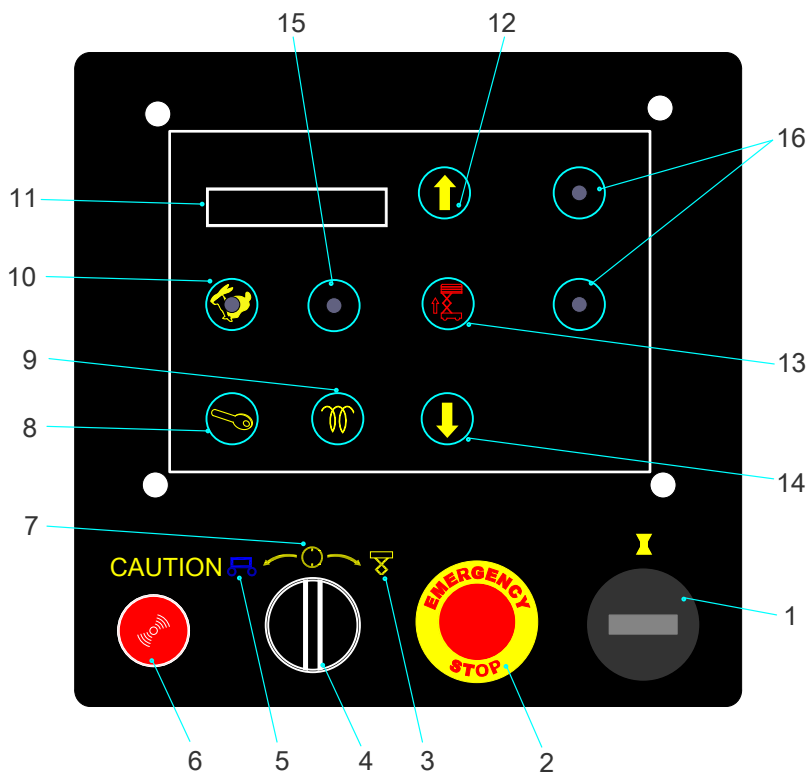

Figure 5-7 Ground controller

Table 5-7

1. Hour meter	7. OFF position	13. Platform lift enable switch
2. Emergency stop button	8. Engine start switch	14. Platform down switch
3. Platform position	9. Engine preheat switch	15. Overload indicator light
4. Key switch (Ground/Platform select switch)	10. Engine high/low idle speed select switch (with indicator light)	16. Emergency lowering switch
5. Ground position	11. LCD screen	
6. Buzzer	12. Platform up switch	

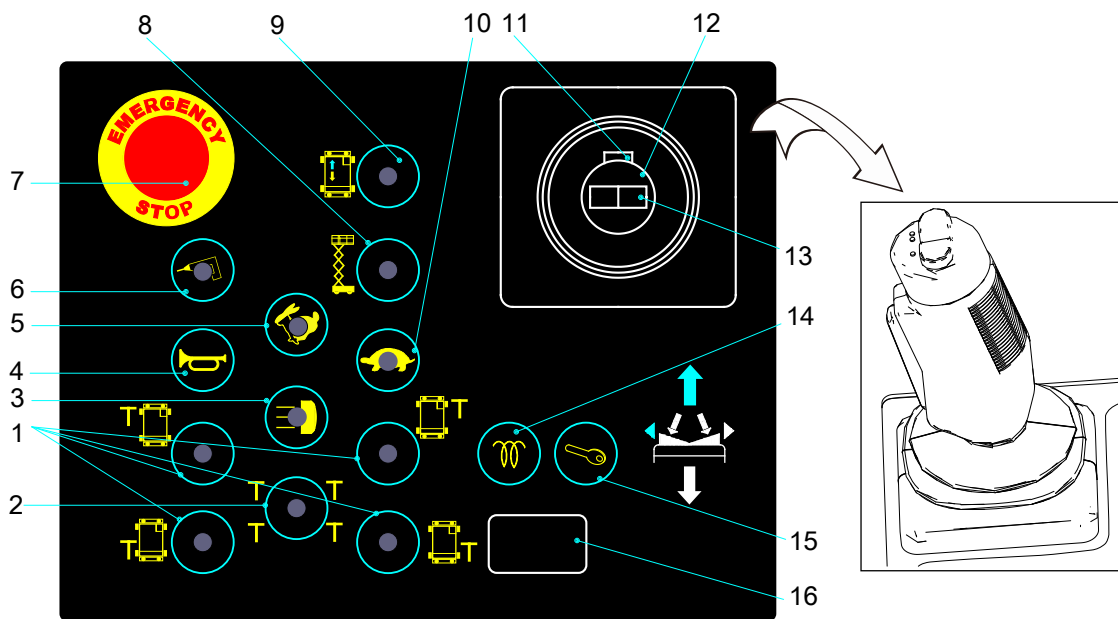

Figure 5-8 Platform controller

Table 5-8

1. Individual outrigger level switch	7. Emergency stop button	13. Steer thumb rocker switch
2. Outrigger self-level switch	8. Platform lift switch	14. Engine preheat switch
3. Lighting switch (option)	9. Drive switch	15. Engine start switch
4. Horn button	10. Drive high/low speed switch	16. LCD screen
5. Engine high/low idle switch	11. Enable switch	
6. Generator switch (if equipped)	12. Drive/lift proportional control joystick	

A-15 Perform Maintenance after 30 Days

Perform maintenance on a new machine after the machine is operated for 30 days or 50 hours. After performing the 30-day maintenance, continue performing maintenance as scheduled.

Perform the following procedures :

- B-2 Inspect rims, tires and fasteners
- B-11 Inspect drive reducer oil level

CHECKLIST B PROCEDURES

B-1 Inspect Electrical Wiring

Maintaining electrical wiring in good condition is vital to safe operation and good machine performance. Continued use of the machine with damaged electrical wiring or in corrosive environment will cause severe injury. Before operating the machine, be sure to replace or repair the damaged or corroded electrical wires.

 **WARNING**



ELECTROCUTION HAZARD

Before inspecting the electrical wires, be sure to disconnect the battery and the charger on the AC outlet. Contact with hot or live circuits could result in death or serious injury.

1. Inspect the following areas for damage or corrosion :
 - Engine wiring harness
 - Scissor arm harness
 - Terminal box at ground controller
 - Terminal box at platform controller
 - Battery harness
 - Chassis harness
2. Ensure each adjustable connector is tight and the sensor wiring free of damage.

B-2 Inspect Rim, Tire and Fasteners

Good maintenance of rims and tires is vital to safe machine operation. The machine might tip over if the

rim or the tire has problems. Repair any problems with the rims and tires before operating the machine.

The machine is equipped with solid tires that do not need to be inflated.

1. Inspect the tires on a daily basis for damage or excessive wear. If any of the following condition occurs, immediately remove the machine from service and replace tires or tire assembly (including rims). For the requirements and procedure for the replacement, please reference [Tires and Rims, page 6-3](#).
 - Play separation of tires, i.e., circumferential rips or lamination occurring to in between the rubbers.
 - Detachment from rims: the rubber comes off from the steel rims.
 - Rubber surface locally peeling off in lumps.
 - Rubber cracks in radial direction.
 - Rubber worn to the wear mark.
2. Inspect the lug nuts are torqued to specification (265Nm[195.3ft-lb]).

NOTICE

Tighten the lug nuts prior to the first use or after each tire removal, inspect and retorque every 3 months or 150 hours of operation.

B-3 Inspect Hydraulic Oil

Inspecting and replacing the hydraulic oil is vital to proper machine operation and extending service life. The machine may be unable to operate properly if the hydraulic oil becomes dirty, and the hydraulic parts may be damaged if using contaminated oil. Replace the hydraulic oil often, especially when the service environment is very dirty.

Note: Due to wear and tear on the mesh components, metal particles may appear in the hydraulic fluid or filter of the new machine.

 **WARNING**



BURN HAZARD

Before maintaining the hydraulic system, allow the hydraulic fluid to cool to room temperature.

Replace the hydraulic oil if any of the following conditions exist :

- The hydraulic oil is milky white and cloudy.

- The hydraulic oil is blackened.
- Obtain a sample of the hydraulic oil and inspect it in sunlight. Rub the oil between two fingers to determine if it contains metal particles.
- The hydraulic oil has an abnormal smell.

See [D-3 Replace Hydraulic Oil, page 5-22](#) for the replacement steps.

B-4 Inspect Cooling System

Inspecting cooling system on a regular basis is vital to proper operation of engine and extending service life.

WARNING	
	<p>BURN HAZARD</p> <p>Be cautious of the heated parts of engine. Bodily contact with them may result in severe burn.</p>

NOTICE
<i>Shut off the engine before inspection.</i>

- Inspect the cooling system for leakage or loose connections.
- Inspect all hoses for crack, abrasion, free of getting flattened, and clamps tightly secured.
- Ensure the cooling fins are not blocked by debris.

B-5 Replace Fuel filter Element

Replacing fuel filter on a regular basis is vital to proper operation of engine and extending service life. A dirty or blocked filter may cause the machine to work improperly, and continued operation may result in component damage. The fuel filter should be replaced at increased frequency if the machine uses fuel of inferior quality or operates in humid environment.

NOTICE
<i>Shut off the engine before inspection.</i>

WARNING	
EXPLOSION AND FIRE HAZARD	
	<ul style="list-style-type: none"> • Diesel is an inflammable material. This procedure must be performed outdoors in well-ventilated area and far away from flames. • Ensure that a conforming fire extinguisher is readily accessible when performing this inspection procedure.

1. Open the engine cover.
2. Locate the fuel filter (see [A-12 Inspect Fuel Filter, page 5-10](#)).
3. Disconnect the fuel flow from the fuel tank to the fuel filter.
4. Loosen the valve plug over the fuel filter.
5. Place a suitable vessel under the fuel filter.
6. Remove the drain plug at the bottom to drain the water and the remaining fuel into the vessel.
7. Remove the fuel filter, replace with a new one and install.
8. Tighten the plug.
9. Clean up the fuel spills.
10. Start the engine from the ground controller and inspect the fuel filter for leakage.

B-6 Inspect Air filter of Hydraulic Tank

Keeping the breather cap of hydraulic tank in well-ventilated condition is vital to normal operation of hydraulic pump and extending service life. Dirty or blocked air filter of hydraulic tank may cause the hydraulic pump to suction improperly, and continued operation may result in component damage. The air filter of hydraulic tank should be inspected more often in hostile operating environment.

NOTICE
<i>Shut off the engine before inspection.</i>

1. Open the front cover on the left side, and locate the hydraulic tank.
2. Remove the air filter from hydraulic tank.

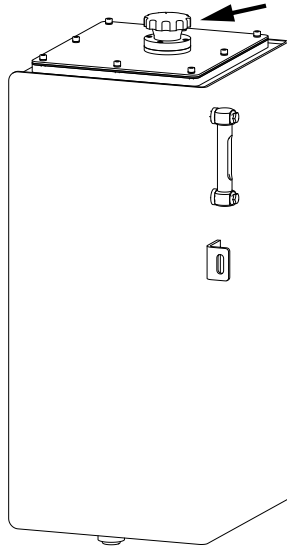



Figure 5-9

3. Check the air filter element
4. The air should pass through the air filter smoothly.
5. If the air has difficulty in passing through the air filter, observe the following steps to clean the air filter.
6. Use neutral solvent to clean the air filter, then blow dry and repeat the Step 2.
7. Install the air filter back to the hydraulic tank.

B-7 Replace High-Pressure Filter Element

Replacing high-pressure filter on a regular basis is vital to proper machine operation and extending service life. A dirty or blocked filter could cause the machine to work improperly, and continued operation may result in component damage. The high-pressure filter should be replaced more often in hostile operating environment.

 WARNING
BURN HAZARD
 <p>Be cautious of hot hydraulic oil. Bodily contact with hot hydraulic oil may result in severe burn.</p>

NOTICE
<i>Shut off the engine before inspection.</i>

1. Open the engine cover and locate the high-pressure filter.

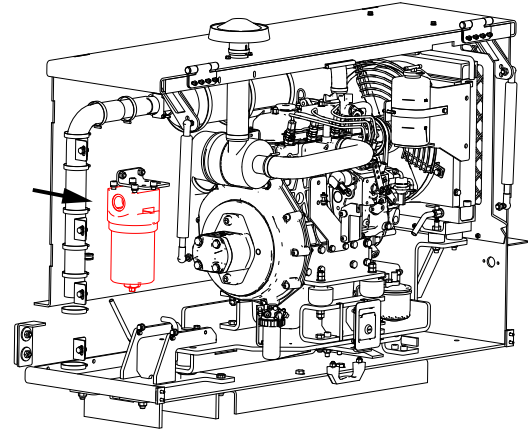

Figure 5-10

2. Place a suitable vessel under the filter.
3. Remove the filter from the mounting bracket.
4. Replace the filter element as needed.
5. Clean up the hydraulic oil spills.
6. Start the engine from the ground controller.
7. Inspect the high-pressure filter and relevant components for leakage.

B-8 Replace Engine Air Filter Element

NOTICE
<i>Shut off the engine before inspection.</i>

Inspecting the engine air filter is vital to proper engine operation. Failure to perform this inspection procedure will result in engine malfunction and component damage.

1. Open the engine cover and locate the engine air filter.

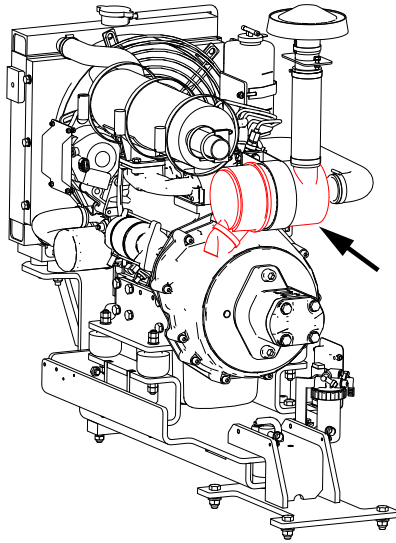

Figure 5-11

2. Loosen the clip at the end cap of air filter, and remove the end cap.
3. Remove the air filter element.
4. Use a wet cloth to scrub the inside of filter housing and end cap.
5. Inspect the filter element for contamination or blockage. Replace the filter element if needed.
6. Install the filter element.
7. Install the end cap back to the filter and secure the clip.

B-9 Inspect the Battery

The condition of the battery affects the performance of the machine. Improper levels of battery electrolyte or damaged cable and wiring may harm battery parts and may pose dangerous conditions.

NOTICE

Be sure to wear protective gloves before inspection.

WARNING



ELECTROCUTION HAZARD

Remove all rings, watches or other jewelry. Contact with energized circuit may result in death or severe injury.

WARNING

BODILY INJURY HAZARD



The battery contains acid, avoid the acid leakage or direct contact with it.
If battery acid spills, use water mixed with baking soda to neutralize the acid.

NOTICE

Wear protective clothing and goggles to inspect the battery after fully charged.

Ensure the battery wiring is tight and free of corrosion.

Ensure the battery holder is properly positioned and secure.

NOTE: Add terminal protectors and antiseptic sealants to help eliminate corrosion of the battery terminals and cables.

NOTE: Ensure the battery is fully charged before testing.

B-10 Inspect Engine Exhaust System

Inspecting engine exhaust system is vital to proper engine operation and extending service life.

NOTICE

Shut off the engine before inspection.

1. Inspect whether the engine exhaust pipe is damaged or crushed flat.
2. Inspect whether the exhaust pipe is tightly connected.
3. Inspect whether the muffler shows signs of heating fatigue or possibility of internal malfunction.
4. Inspect the catalytic converter for blockage.
5. Tighten or replace parts, if needed, to ensure the exhaust system is free of leakage.

B-11 Inspect Drive Reducer Oil Level

Inappropriate gear oil level of drive reducers will reduce the machine performance, and continued use could result in component damage.

1. Drive the machine to rotate the reducer until one bolt at top and the other one at 90 degrees, as shown in the figure below.

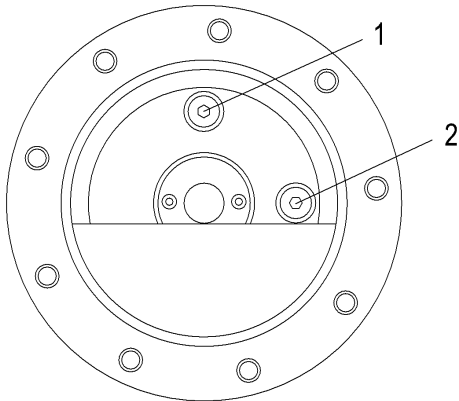

Figure 5-12

2. Remove the bolt #2, and check the oil level.
3. The oil level should be even with the bolt hole.
4. If necessary, add oil to the bolt hole.
5. Remove the bolt #1, add gear oil to the bolt hole #1 until the oil level is even with that of the bolt hole #2.
6. Install the bolts back.
7. Clean up the gear oil spills during the inspection.
8. Perform this inspection procedure to all drive reducers of the machine.

B-12 Test Oscillate Outriggers

NOTICE

Do not stand in the platform but on the ground to perform this testing using platform controller.

The oscillate outriggers enables the machine to drive on uneven surfaces with 4 tires in close contact with the ground, thus improving the traction performance and stability.

- With the machine in stowed position:
 1. Start the machine from the platform controller and select the high idle speed.
 2. Drive the machine to allow the left steer wheel to stand on a 10cm (3.9in) high block or kerb.
 3. The other 3 wheels should come in close contact with the ground.
 4. Drive the machine to allow the right steer wheel to stand on a 10cm (3.9in) high block or kerb.
 5. The other 3 wheels should come in close contact with the ground.

- With the machine in operating position:
 1. Start the machine from the platform controller and select the high idle speed.
 2. Using the platform lift function, raise the platform until the lower limit switch disengages.
 3. Drive the machine to allow the left steer wheel to stand on a 10cm (3.9in) high block or kerb.
 4. The other 3 wheels should come in close contact with the ground.
 5. Drive the machine to allow the right steer wheel to stand on a 10cm (3.9in) high block or kerb.
 6. The other 3 wheels should come in close contact with the ground.

B-13 Test Drive Speed

With the machine in stowed position:

1. Turn the Ground/Platform select switch on ground controller to Platform.
2. Pull out the emergency stop buttons on ground and platform controllers to ON position.
3. Press the engine start switch on platform controller.
4. Press the drive switch.
5. Hold the joystick enable switch and slowly deflect forward the joystick to full stroke.
6. Press the drive high/low speed switch on platform controller to select the high drive speed.
7. The max drive speed of the machine in stowed position is $5\pm 0.5\text{Km/h}$ ($3.12\pm 0.31\text{mph}$), or the drive time for 40m(131 ft) is 28 ~ 35s.

With the machine in operating position:

1. Turn the Ground/Platform select switch on ground controller to Platform.
2. Pull out the emergency stop buttons on ground and platform controllers to ON position.
3. Press the engine start switch on platform controller.
4. Press the platform lift switch.
5. Hold the joystick enable switch and slowly deflect forward the joystick to raise the platform, and release the joystick when the lower limit switch disengages.
6. Press the drive switch.
7. Hold the joystick enable switch and slowly deflect forward the joystick to full stroke.
8. Press the drive high/low speed switch on platform controller to select the high drive speed.
9. The max drive speed of the machine in stowed position is $0.48\pm 0.048\text{Km/h}$ ($0.3\pm 0.03\text{mph}$) , or the drive time for 20m (65.6 ft) is 136 ~ 166s.

NOTICE

If the machine drive speed exceeds the test results above, immediately tag and remove the machine from service.

B-14 Test Tilt Protection System

NOTICE

Do not stand in the platform but on the ground to perform this testing using platform controller.

1. Position the machine on a level, firm surface. Start the machine, the green indicator with the level sensor should illuminate.
2. With the machine in stowed position, place 2 wooden blocks near the two front or rear wheels, then drive the machine upon the wooden blocks. The wooden block dimension (L×W×H) is 100×50×150mm (4in×2in×5.9in).
3. Switch from drive to platform lift function, and raise the platform until the lower limit switch disengages, the red indicator light of the level sensor will illuminate with the alarm sounding, further lifting and driving is restricted.
4. Lower the platform to the stowed position, the alarm qill stop sounding, and the machine function limit is cancelled.
5. Drive the machine off and remove the wooden blocks.
6. With the machine in stowed position(outrigger retracted), place 2 wooden blocks near the two wheels on the left or right side, then drive the machine upon the wooden blocks. The wooden block dimension (L×W×H) is 100×50×70mm (4in×2in×2.76in).
7. Switch from drive to platform lift function, and raise the platform until the lower limit switch disengages, the red indicator light of the level sensor will illuminate with the alarm sounding, further lifting and driving is restricted.
8. Lower the platform to the stowed position, the alarm qill stop sounding, and the machine function limit is cancelled.
9. Drive the machine off and remove the wooden blocks.
10. With the machine in stowed position(outrigger extended), place 2 wooden blocks near the two wheels on the left or right side, then drive the machine upon the wooden blocks. The wooden block dimension (L×W×H) is 100×50×28mm (4in×2in×1.1in).

11. Switch from drive to platform lift function, and raise the platform until the lower limit switch disengages, the red indicator light of the level sensor will illuminate with the alarm sounding, further lifting and driving is restricted.
12. Lower the platform to the stowed position, the alarm qill stop sounding, and the machine function limit is cancelled.
13. Drive the machine off and remove the wooden blocks.

B-15 Test Brake Distance

Proper brake action is vital to safe machine operation. The drive brake function should operate smoothly, free of hesitation, jerking or unusual noise, otherwise the machine should be removed from service.

Note: The machine must be positioned on level firm surfaces clear of obstructions before performing this procedure.

NOTICE

The brake must be able to hold the machine on any slope it is able to climb.

With the machine in stowed position:

1. Turn the Ground/Platform select switch on the ground controller to Platform;
2. Pull out the emergency stop buttons on platform and ground controllers to ON position;
3. Push the engine start switch.
4. Push the drive high/low speed select switch on the platform controller to select the high speed position;
5. Push the drive enable switch.
6. Hold the enable switch on the joystick and slowly deflect the joystick to full drive speed position;
7. Quickly release the joystick after the full drive speed is reached;
8. Measure the braking distance of the machine.
Result: braking distance ≤ 0.8m (2.6ft).

With the machine in operating position:

1. Turn the Ground/Platform select switch on the ground controller to Platform;
2. Pull out the emergency stop buttons on platform and ground controllers to ON position;
3. Push the engine start switch;
4. Push the lift enable switch;
5. Hold the enable switch on the joystick and slowly deflect the joystick to raise the platform, and

release the joystick when the lower limit switch disengages.

6. Push the drive enable switch;
7. Hold the enable switch on the joystick and slowly deflect the joystick to full drive speed position;
8. Quickly release the joystick after the full drive speed is reached;
9. Measure the braking distance of the machine.
Result: braking distance ≤ 0.15m (5.9in).

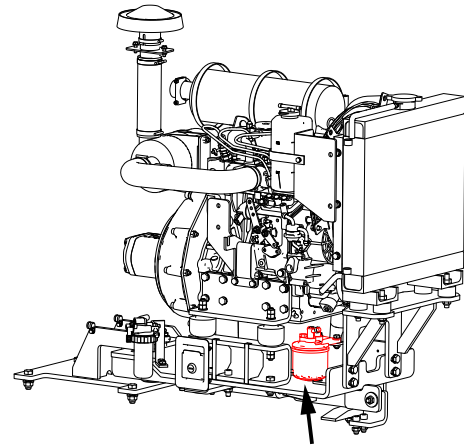





Figure 5-13

CHECKLIST C PROCEDURES

C-1 Replace Fuel Filter Element

Regularly replacing fuel filter element is vital to good engine performance and extending service life. A dirty or blocked filter may fail the engine and continued use may result in component damage. The filter element should be replaced more often if operating the machine in hostile environment.

 WARNING	
EXPLSION AND FIRE HAZARD	
	<ul style="list-style-type: none"> Diesel is an inflammable material. This procedure must be performed outdoors in well-vented area and far away from flames.
	<ul style="list-style-type: none"> Ensure that a conforming fire extinguisher is readily accessible when performing this inspection procedure.

NOTICE
<i>Shut off the engine before inspection.</i>

1. Open the engine cover, and locate the fuel filter;

2. Disconnect and cap the line between fuel tank and fuel filter;
3. Using a wrench, remove the fuel filter element;
4. Coat a thin layer of fuel on the sleeve of the new filter element before tightening the screws.
5. Fully hand tighten the filter element.
6. Loosen the bleed plug to let out the air.
7. Start the engine and inspect for fuel leaks.

C-2 Replace Engine Oil

NOTICE
<i>The engine oil filter must also be replaced after replacing the engine oil. Replace the oil with engine started to circulate the oil more smoothly and avoid contamination.</i>

1. Turn the Ground/Platform select switch on the ground controller to Ground.
2. Pull out the emergency stop button on the ground controller to ON.
3. Push the engine start button to idle for 5min and shut off.
4. Place an oil pan under the engine.
5. Remove the drain plug at the engine bottom to fully drain the oil.

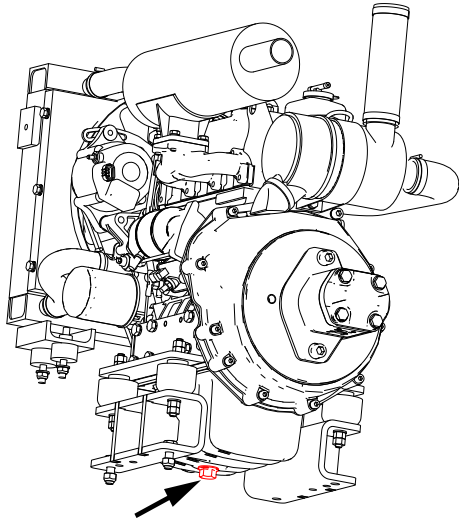

Figure 5-14

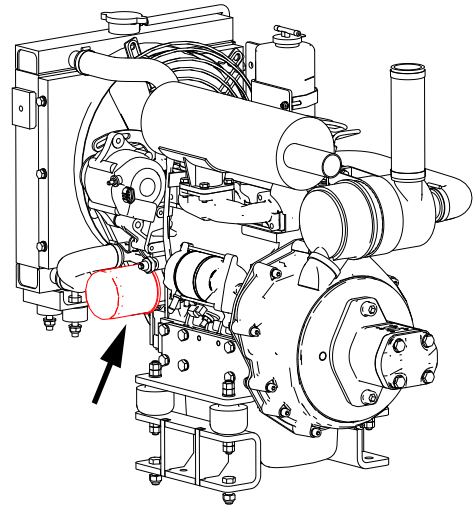

Figure 5-15

⚠ WARNING

BURN HAZARD

Do not come in contact with the hot engine oil when draining to avoid burns.

NOTICE

The waste engine oil should be collected in a suitable vessel for disposal or recycling. The waste engine oil should be treated in compliance with the environment laws or regulations.

6. Tighten the drain plug.
7. Add the new engine oil. For the recommended viscosity grade of the engine oil, please reference [A-8 Inspect Engine Oil Level, page 5-8](#).

C-3 Replace Engine Oil Filter

NOTICE

Replace the engine oil filter each time the engine oil is replaced.

1. Clean the areas around the filter.
2. Remove and discard the seal ring of the engine oil filter.
3. Thoroughly clean the residues on the seal surface of the filter support.
4. Apply clean engine oil to the rubber washer of the new engine filter.
5. Mount the new filter.
6. For the engine oil level inspection procedure, please reference [A-8 Inspect Engine Oil Level, page 5-8](#).
7. Inspect the engine oil filter element to make sure no leakage occurs.

C-4 Test Weighing System

1. Before conducting this test, fully lift and lower the platform twice to ensure normal lubrication of the slider and track.
2. Lower the platform to the minimum height and retract the extension platform. With the scissor arm fully retracted, gradually add loads to the platform.

Table 5-9

Models	Test Results
1018RD	When the weight does not exceed 450 kg (992 lb), ensure that the platform is able to lift to the highest position. When the weight is greater than or equal to 540 kg (1190 lb), the platform lifting height should be no greater than 3±0.5m (9ft 10in±1ft 8in) .
1218RD	When the weight does not exceed 365 kg (805 lb), ensure that the platform is able to lift to the highest position. When the weight is greater than or equal to 438 kg (966 lb), the platform lifting height should be no greater than 3.2±0.5m (10ft 6in±1ft 8in) .

Note : The hydraulic oil viscosity will increase as the temperature reduces, which may adversely affect the pressure sensing. If the new machine operates at temperature conditions that differ with the OEM factory temperature by more than 10°(50°F), or the hydraulic oil temperature is below 15°(59°F), the overload alarm may be triggered (the display screen on platform or ground controller indicates “OL”) even if the platform load does not exceed the rated load, in this circumstance, please re-calibrate the weight sensor.

5. Push in the emergency stop button on the ground controller to OFF position.
6. Measure the height of platform floor above the ground. (3.0±0.3m[9ft 10in±12in])

CHECKLIST D PROCEDURES

C-5 Test Secondary Lowering

Test the lowering delay function

1. Turn the Ground/Platform select switch on the ground controller to Ground.
2. Pull out the emergency stop button on the ground controller to ON position.
3. Raise the platform approx. 3m (9ft 10in).
4. Lower the platform until the secondary lowering function is activated and the platform will stop lowering.
5. Quickly release and immediately push again the platform down switch.
6. The platform will rest for 4–6s and continue lowering to the stowed position.
7. Push in the emergency stop button on the ground controller to OFF position.

Measure the secondary lowering startup height

1. Turn the Ground/Platform select switch on the ground controller to Ground.
2. Pull out the emergency stop button on the ground controller to ON position.
3. Raise the platform approx. 3m (9ft 10in).
4. Lower the platform until the secondary lowering function is activated and the platform will stop lowering.

D-1 Replace Drive Reducer Gear Oil

Regularly replacing drive reducer gear oil is vital to good machine performance and extending service life of the reducer.

1. Drive the machine to rotate the reducer to the position with one bolt at the bottom, as shown in the figure below.

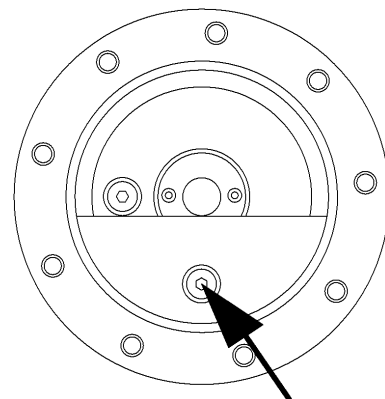

Figure 5-16

2. Place a suitable vessel under the bolt as indicated by the arrow in the figure.
3. Remove the bolt as indicated.
4. Fully drain the drive reducer gear oil to the vessel.
5. Mount back the loosened bolt.

6. Drive the machine to rotate the reducer until one bolt is at top and the other is at 90 degrees.

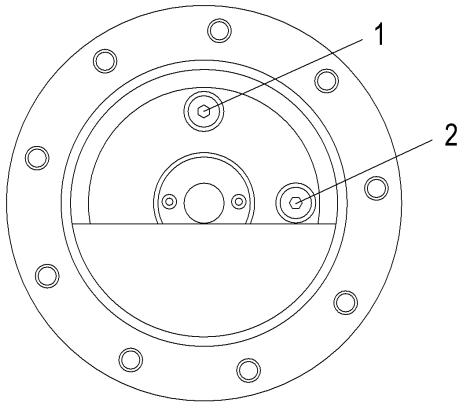

Figure 5-17

7. Remove the #1 and #2 bolts as indicated.
8. Add new gear oil to the port #1 until the oil level is even with that of the port #2.
9. Mount back the bolts.
10. Clean up the oil spills in performing the inspection procedure.
11. Perform the same procedure on all drive reducers of the machine.

D-2 Inspect Scissor Arm Sliders

Proper maintenance of the sliders connecting scissor arm to the chassis and platform is vital to safe machine operation. The sliders serve as friction pair by sliding on the channel steel surface of the chassis and platform. Unsuitable sliders or continued use of old sliders may result in component damage or hazardous situations.

NOTICE

The scissor arm must be fully retracted before performing this procedure.

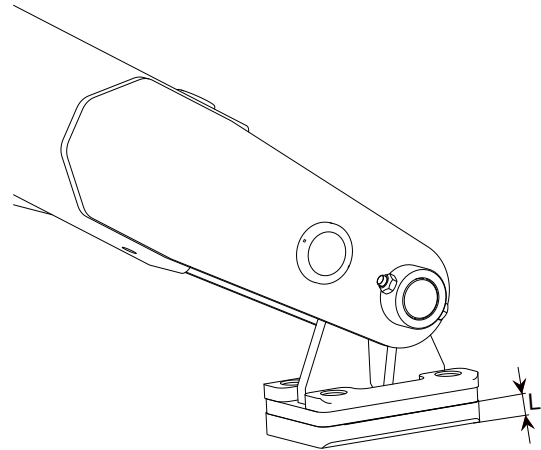

Figure 5-18

1. Measure the thickness L of sliders on the chassis (- Reference size : 12mm [0.47in]).
2. When the wear degree of any slider exceeds 3mm [0.12in] (L<9mm [0.35in]), replace all sliders on the chassis.
3. Measure the thickness L of sliders on the platform (- Reference size : 12mm [0.47in]).
4. When the wear degree of any slider exceeds 3mm [0.12in] (L<9mm [0.35in]), replace all sliders on the platform.

D-3 Replace Hydraulic Oil

Regularly replacing hydraulic oil is vital to good machine performance and extending service life. Unqualified cleanliness of oil may cause the machine to perform poorly and continued use may result in hydraulic component damage. Particularly harsh working condition requires the oil changes to be performed more frequently.

WARNING

BURN HAZARD



Before servicing the hydraulic system, allow the hydraulic oil to cool down to room temperature.

NOTICE

The inspection must be performed with the engine in off position.

When removing the hose and fittings, the O-rings on the hose and fittings must be replaced.

1. Open the left door of chassis, and locte the hydraulic tank.
2. Close the hdyraulic cutoff valve beside the tank.
3. Remove the drain plug at the tank bottom to drain the oil into a suitable vessel. For the hydraulic tank capacity, please reference [Machine Specifications, page 1-1](#). After completely drained, re-install the drain plug.

 WARNING
<p style="text-align: center;">HIGH PRESSURE HAZARD</p> <p>Slowly remove the hydraulic elements to reduce the oil pressure. High oil pressure may penetrate the skin. Should any injury occur, go to a doctor at once.</p>

4. Clean up the oil leaks, if any, and properly dispose of the used oil.
5. Clean the inside of the tank using a mild solvent, and dry it up.
6. Tighten the drain plug, add a suitable amount of hydraulic oil to the tank, be careful not to overfill.
7. Open the hydraulic cutoff valve on the tank side.
8. Start the pump to deliver the oil into the hydraulic system and remove air from the system.

D-4 Replace Hydraulic Tank Suction Filter

Regularly replacing hydraulic tank suction filter is vital to good machine performance and extending service life. Dirty hydraulic oil may cause the machine to function improperly and continued use may result in hydraulic component damage. Extremely dirty condition requires the oil changes to be performed more frequently.

When performing the procedure [D-3 Replace Hydraulic Oil, page 5-22](#), the hydraulic tank suction filter must also be replaced.

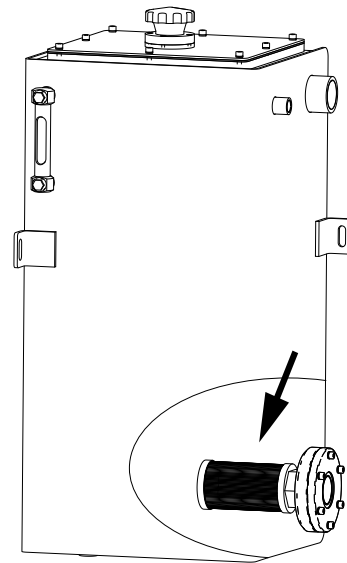

Figure 5-19

D-5 Inspect Scissor Arm Bearings

Proper maintenance of scissor arm bearings is vital to safe machine operation. Continued use of old bearings may result in component damage or hazardous situations.

NOTICE
<p><i>The scissor arm must be fully retracted before performing this procedure.</i></p>

1. Use a feeler gauge to measure the fitting clearance between the pin and bearing.
2. If the fitting clearance exceeds 0.3 mm (0.011 in) or the bearing is in service for over 10 years, the bearing must be replaced.

This Page Intentionally Left Blank

6 REPAIR

WARNING



Repair procedures must be performed by qualified, trained and competent personnel in a properly equipped workshop.

Replace or repair damaged components immediately. Do not operate the machine with known damaged components.

Be sure the machine is properly maintained before operating it.

Before starting the machine:

- Read, understand and follow all safety rules and instructions in this manual.
- Read all procedures and specifications completely.
- Unless otherwise specified, perform all maintenance procedures per the following:
 - Park the machine on flat, level and firm ground.
 - Be sure the platform is fully retracted.
 - Turn the key switch to the “OFF” position and remove the key.
 - Chock all wheels.

NOTICE

Perform this procedure with the machine in stowed position.

1. Disconnect external power supply, and push in the emergency stop buttons on the platform and ground controllers to OFF position.
2. Locate the cable connected to the bottom of the platform controller.
3. Disconnect and tag the cable from the bottom of the platform controller.
4. Remove the platform controller and mounting bracket.
5. Move the platform controller and mounting bracket away from the machine.

Platform Assembly

WARNING

MOVING OBJECT HAZARD



Wear eye protection while tapping the brass drift with a wooden hammer.

1. Remove the platform controller from the platform. For details, see [Platform Controller, page 6-1](#).
2. Raise the platform to a certain height until the pin connecting the scissor to the platform is accessible.
3. Set up the safety arm.
4. Using an appropriate lifting device, attach the straps to the four lifting points as shown in the Figure below.

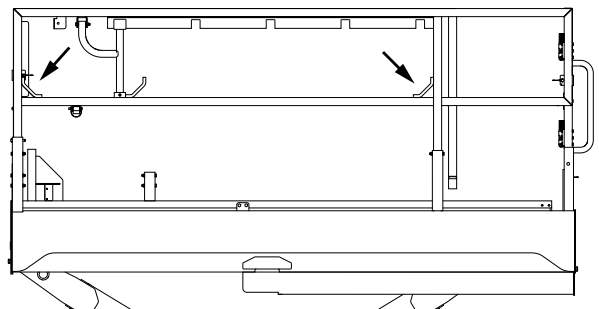

PLATFORM COMPONENTS

Platform Controller

WARNING



ELECTROCUTION HAZARD

Before performing this procedure, be sure to disconnect the battery and the charger on AC outlet. Contact with live conductors may result in death or serious injury.

Figure 6-1

5. Remove the bolts at the pins connecting the scissor and the platform.

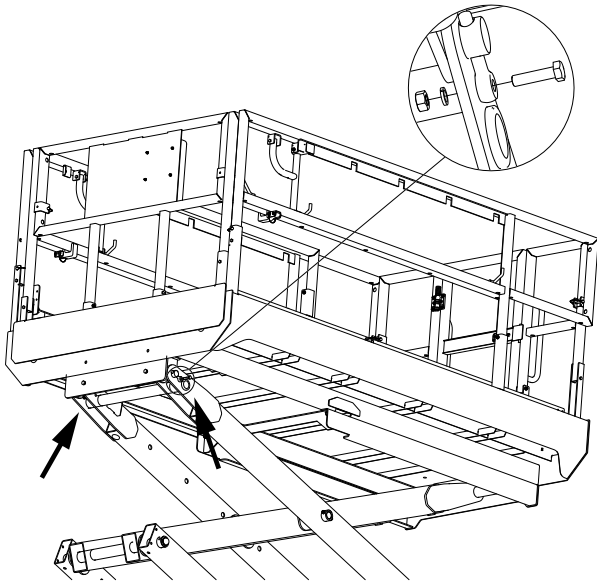



Figure 6-2

6. Tap the connecting pins out using brass drift and wooden hammer.
7. Raise and push the platform to reach the sliders to the platform notch.
8. Using the lifting device, slowly lift the platform clear of the machine.

Extension Platform

 WARNING	
	<p>CRUSH HAZARD</p> <p>When removing the extension platform from the machine, the extension platform may lose balance and fall down if not properly supported or secured to the forklift.</p>

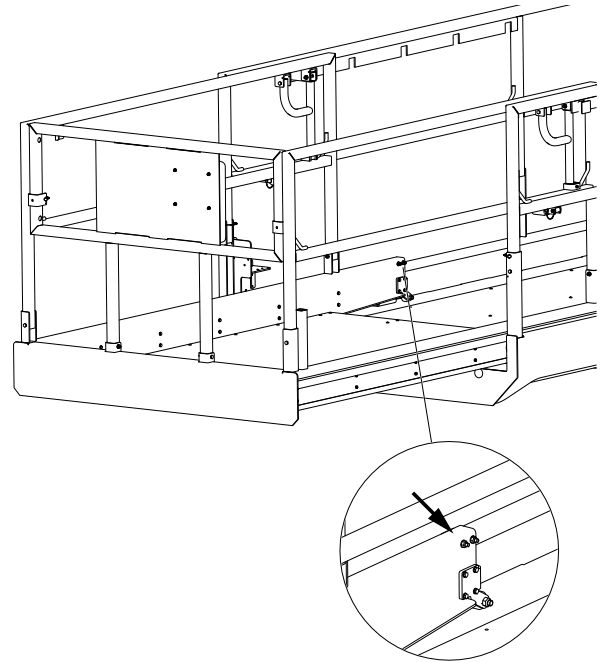

Figure 6-3

1. Remove the retaining fasteners at the bottom of the extension platform as shown in the above Figure, and then remove the hook secured.
2. Repeat the above step on the other side of extension platform.
3. Insert the forklift arms into the bottom of the extension platform for support.
4. Carefully slide the extension platform off the stationary platform.

SCISSOR COMPONENTS

Scissor Assembly

1. Remove the platform.
2. Disconnect the cables and hoses routing through the chassis and scissor.

<p>NOTICE</p>
<p><i>When removing the hoses and fittings, the O-rings at the hose ends or fittings must also be removed and tagged.</i></p>

3. Using appropriate lifting device, attach the straps to the scissor assembly.

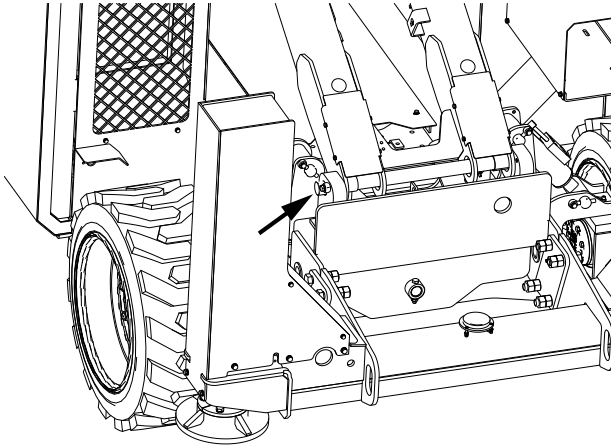

Figure 6-4

4. Remove the bolts and pins securing the scissor to the chassis.

WARNING

CRUSH HAZARD

Do not allow your hands, or other parts of your body, or clothes to contact with the moving parts of machine.

5. Move the lifting device horizontally to detach the sliders from the channel.
6. After all sliders become detached from the channels, exercise extreme cautions to lift the scissor assembly clear of the chassis.

Lift Cylinder

WARNING

HIGH-PRESSURE HAZARD

Slowly remove the hydraulic components to reduce hydraulic oil pressure. High hydraulic oil pressure could penetrate the skin. Seek medical attention immediately if hurt.

1. Raise the scissor arm far enough to allow the safety arm to be engaged.
2. Set up the safety arm and properly lower the platform such that the safety arm can adequately support the scissor arm.
3. Attach the straps of a lifting device to the scissor arm assembly.

4. Disconnect and cap the hydraulic hoses and fittings from the hydraulic cylinder.

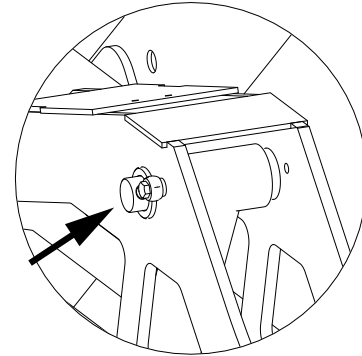

Figure 6-5

5. Remove the retaining bolts and dowel pins from the guide sleeve of cylinder rod.
6. Remove the retaining bolts and dowel pins connecting the cylinder end and the scissor arm.

NOTICE

Exercise extreme caution when removing the cylinder. Do not allow the cylinder to drop and become damaged.

7. Tap the pins out using brass drift and wooden hammer.

WARNING

MOVING OBJECT HAZARD

Wear eye protection while tapping the brass drift with wooden hammer.

8. Carefully pull out the cylinder.

CHASSIS COMPONENTS

Tires and Rims

Replacing tires and rims

Hunan Sinoboom Intelligent Equipment Co., Ltd. recommends the replacement tires be of the same size, ply rating and brand as the original tires. For the part number of a specific machine model, please reference the Part Manual. If the replacement tires are not as Hunan Sinoboom Intelligent Equipment Co., Ltd.

recommends, the following requirements of tires should be met :

1. Ply rating/rated load and dimension equal or greater than original.
2. Tire tread contact width equal or greater than original.
3. Wheel diameter, width and offset dimensions equal to the original.
4. Approved for the application by the tire manufacturer (including intended purposes, maximum drive speed and maximum tire load, etc.).
5. Due to size variations between different tire brands, both tires on the same axle should be the same.

! WARNING

UNSAFE OPERATION HAZARD

The tires and rims installed on each product model have been designed for stability requirements. Size changes such as rim width, center piece location, diameter, etc., without written factory recommendations, may result in an unsafe condition regarding stability.

Installing tires and rims

It is extremely important to apply and maintain proper wheel mounting torque.

! WARNING

UNSAFE OPERATION HAZARD

- Use the wheel nuts that suit the rim bolts. The wheel nuts must be installed and maintained at the proper torque to prevent loose wheels, broken studs and possible dangerous separation of wheels from the axle. Be sure to only use the nuts matched to the cone angle of the wheel.
- Tighten the lug nuts to the proper torque to prevent wheels from coming loose. Use a torque wrench to tighten the fasteners. If you do not have a torque wrench, tighten the fasteners with a socket wrench, then immediately have a service garage or dealer tighten the lug nuts to the proper torque. Over-tightening will result in breaking the studs or permanently deforming the mounting stud holes in the wheels.

The proper procedure for attaching wheels is as follows:

1. First apply the threadlocker Loctite 272 to the nuts, then hand tighten all nuts to prevent cross-threading. Do not use a lubricant on threads or nuts.
2. Tighten the nuts in the sequence as shown below.

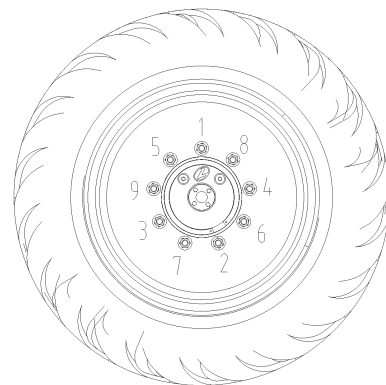

Figure 6-6

3. The tightening of the nuts should be done in stages. Following the recommended sequence, tighten nuts per wheel torque as listed in the table below.

Table 6-1

1st Stage	2nd Stage	3rd Stage
30Nm (96ft-lb)	210Nm (155ft-lb)	265Nm (195ft-lb)

NOTICE

Wheel nuts should be torqued prior to first use of machine and after each wheel removal. Check torque every 3 months or 150 hours of operation.

Reducer and Rear Drive Motor

The reducer and drive motor act not only the role of driving the machine but also the role of securing the rear wheel. Before removing the reducer and motor, secure the machine on a suitable structure or support the machine by a jack of ample capacity.

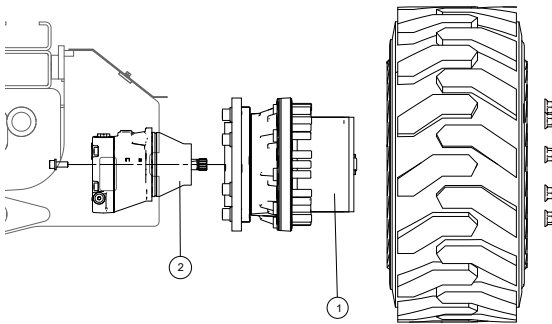

Figure 6-7

No.	Description
1	Reducer
2	Drive motor

Removal of reducer and rear drive motor

1. Place the machine on a solid, level surface.
2. Place a jack of sufficient capacity under the side of chassis to be removed. Lift the jack to make the wheel off the ground.
3. Remove the bolts and washers securing the wheel to the reducer. Use a suitable lifting device to remove the wheel.
4. Tag, disconnect and plug the hydraulic hoses and fittings to the drive motor.
5. Remove the bolts and washers securing the drive motor to the reducer, and remove the drive motor.

6. Remove the bolts and washers securing the the reducer to the outriggers, and remove the reducer.

Installation of reducer and rear drive motor

1. Use a lifting device with sufficient capacity to support the outrigger.
2. Align the reducer brake oil port with the nick of outrigger.
3. Fit the washer with the mounting surface, apply threadlocker Loctite 272 to the bolts, and install in turns.
4. Tighten the bolts with a torque wrench.
5. After all installed, add a suitable level of gear oil.
6. Clean the mount surface, lift the rear drive motor and align it with the reducer: the motor spline shaft in mesh with the inner gear of reducer, and the motor mounting slot aligned with the reducer mounting hole.
7. Apply the threadlocker Loctite 272 to the bolts and torque the bolts after pretightening.
8. Attach the hydraulic hoses.
9. Install the wheel.

Front Drive Motor

The front drive motor act not only the role of driving the machine but also the role of securing the front wheel. Before removing the reducer and motor, secure the machine on a suitable structure or support the machine by a jack of ample capacity.

1. Place the machine on a solid, level surface.
2. Place a jack of sufficient capacity under the side of chassis to be removed. Lift the jack to make the wheel off the ground.
3. Remove the clamp board from the front wheel motor.
4. Remove the castle nut securing the tire, use a suitable crane to remove the front wheel.
5. Tag, disconnect and plug the hydraulic hoses to the drive motor.
6. Remove the bolts and nuts securing the drive motor to the chassis.
7. Remove the front drive motor.

Steer Cylinder

WARNING

HIGH-PRESSURE HAZARD



Slowly remove the hydraulic components to reduce hydraulic oil pressure. High hydraulic oil pressure could penetrate the skin. Seek medical attention immediately if hurt.

NOTICE

When re-installing, torque the hoses and fittings to specifications as shown in *Hydraulic Hose and Fitting Specifications, page 1-6*.

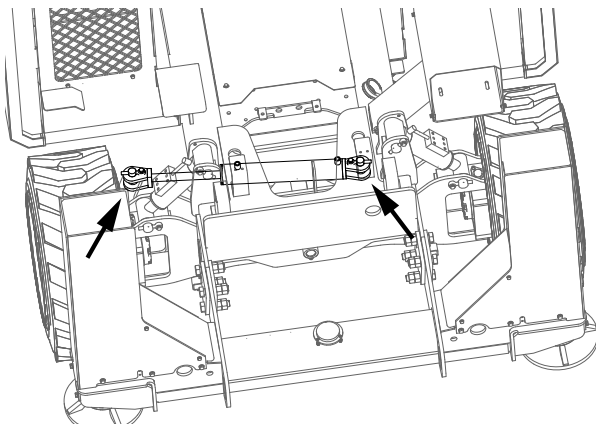

Figure 6-8

1. Tag, disconnect and plug the hoses and fittings to the steer cylinder.
2. Remove the cotter pin at the pivot pin connecting the steer cylinder and disc to the outrigger, and remove the pivot pin.

NOTICE

Exercise extreme caution when removing the cylinder. Do not allow the cylinder to drop and become damaged.

3. Remove the steer cylinder from the machine.

Steer Linkage

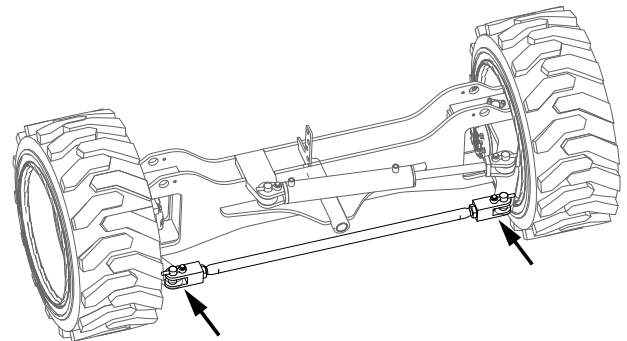



Figure 6-9

1. Remove the dowel pin and bolt at the pin connecting the steer linkage and the disc.
2. Using brass drift and wooden hammer, tap the pin out.

WARNING

MOVING OBJECT HAZARD



Wear eye protection while tapping the brass drift with wooden hammer.

3. Remove the steer linkage from the machine.

Oscillate Cylinder

WARNING

HIGH-PRESSURE HAZARD



Slowly remove the hydraulic components to reduce hydraulic oil pressure. High hydraulic oil pressure could penetrate the skin. Seek medical attention immediately if hurt.

NOTICE

When re-installing, torque the hoses and fittings to specifications as shown in *Hydraulic Hose and Fitting Specifications, page 1-6*.

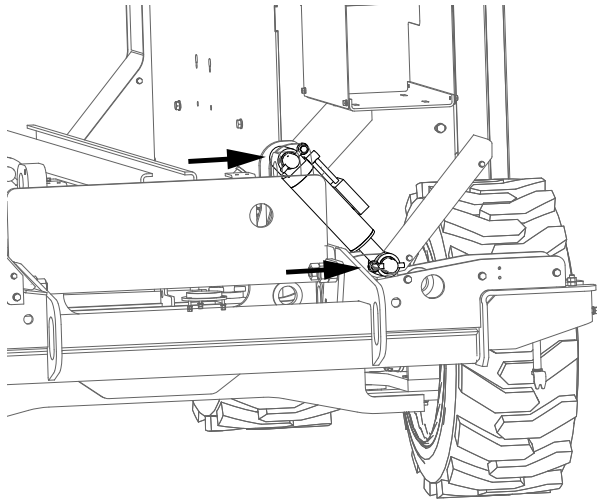

Figure 6-10

1. Tag, disconnect and plug the hoses and fittings to the oscillate cylinder.
2. Secure the non-steer wheels, and place a jack under the oscillate cylinder side to be removed.
3. Remove the dowel pin and bolt at the pin connecting the oscillate cylinder to the chassis and outrigger.

NOTICE

Exercise extreme caution when removing the cylinder. Do not allow the cylinder to drop and become damaged.

4. Using brass drift and wooden hammer, tap the pin out.

WARNING

MOVING OBJECT HAZARD



Wear eye protection while tapping the brass drift with wooden hammer.

5. Remove the oscillate cylinder from the machine.

Ground Controller

1. Open the rear door on the left side of chassis;
2. Remove the butterfly screw and open the ground control panel;
3. Tag and disconnect the cables to the ground controller;
4. Remove the retaining bolts and nuts between ground controller and door.
5. Remove the ground controller.

HYDRAULIC SYSTEM

Layout of Hydraulic Elements

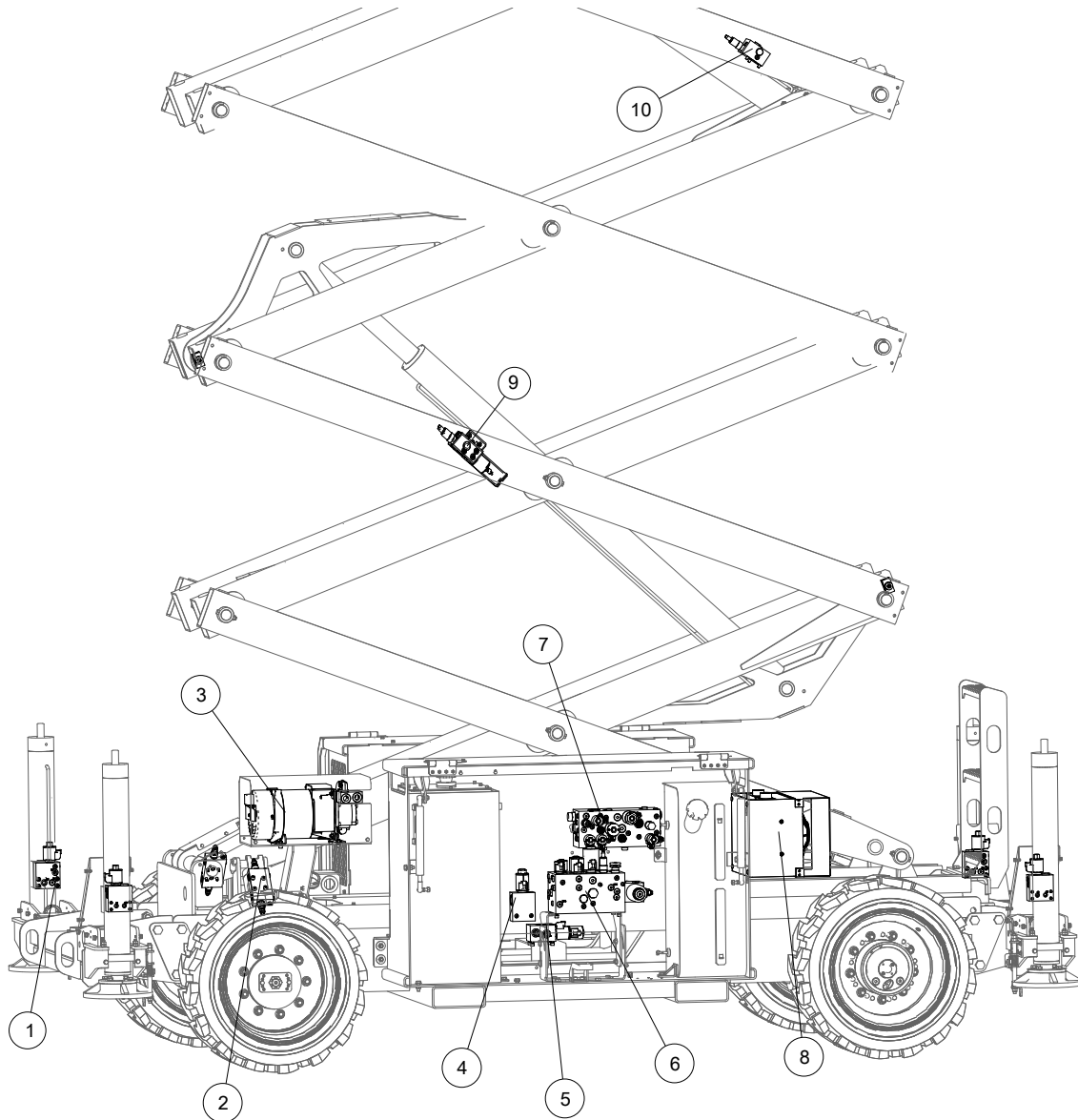

Figure 6-11



Table 6-2

1. Outrigger solenoid valve	5. Outrigger direction control valve	9. Lower lift cylinder control valve
2. Bi-directional counterbalance valve	6. Drive control valve	10. Upper lift cylinder control valve (1218RD only)
3. Hydraulic generator	7. Scissor/platform control valve	
4. Generator control valve	8. Oil cooler	

Hydraulic Tank

WARNING

BURN AND HIGH-PRESSURE HAZARDS

-  Avoid bodily contact while the hydraulic system is still at a high temperature. The hot hydraulic oil may cause severe injury.
-  Ensure the hydraulic oil has cooled down before removing the hydraulic tank.

NOTICE

The engine must be shut off before performing this procedure.
The hoses and fittings must be re-installed and torqued to specifications as shown in *Hydraulic Hose and Fitting Specifications, page 1-6*.

1. Open the front door on the left side of chassis, and locate the hydraulic tank.
2. Shut off the hydraulic cutoff valve at either side of the tank.
3. Remove the drain plug at the bottom, and drain the oil into a suitable vessel. For the hydraulic tank capacity, please reference *Machine Specifications, page 1-1*.

WARNING

HIGH-PRESSURE HAZARD

 Slowly remove the hydraulic components to reduce hydraulic oil pressure. High hydraulic oil pressure could penetrate the skin. Seek medical attention immediately if hurt.

4. Tag, disconnect and plug the hoses and fittings to the hydraulic tank.
5. Loosen the retaining bolts and remove the hydraulic tank from the machine.

Note: Before re-installing the hydraulic tank, be sure to clean and inspect it for cracks or other damages.

Hydraulic Pump



Hydraulic pump is linked to the engine to serve as power source for the hydraulic system.

NOTICE

When re-installing, torque the hoses and fittings to specifications as shown in *Hydraulic Hose and Fitting Specifications, page 1-6*.

WARNING

BURN AND HIGH-PRESSURE HAZARDS

-  Allow the hydraulic components to cool to room temperature before performing service. Loosen the hydraulic hoses and fittings slowly to relieve pressure.
- 

Inspecting hydraulic gear pump

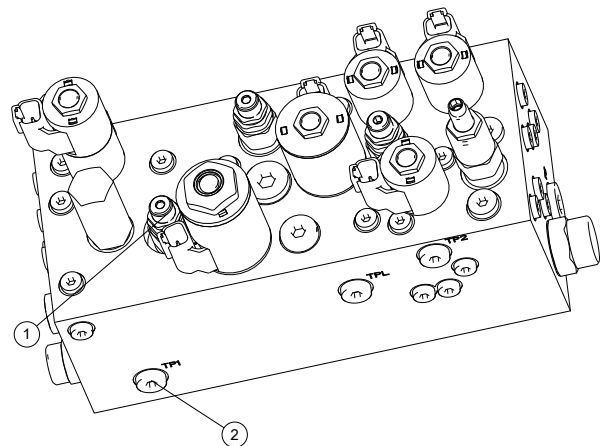

Figure 6-12

Table 6-3

No.	Description	Torque Value
1	Main relief valve	60 Nm (44.3 ft-lb)
2	Pressure test port #1	\

1. Remove the plug of the pressure testing port 1# at the scissor/platform control valve, and install the pressure testing joint.
2. Connect the pressure gauge (range 40MPa) to the pressure testing joint.
3. Turn the Ground/Platform select switch on the ground controller to Platform.

4. Pull out the emergency stop buttons on both ground and platform controllers to ON position.
5. Fully steer the machine to the right/left and remain to hold the pressure, note down the readout on the gauge, the pressure should be 21MPa.
6. If the pressure value is not as specified, adjust the main relief valve pressure as follows :
 - Use an hex wrench to hold the oscillate high-pressure relief valve and loosen the nut.
 - Using a hex wrench, adjust the relief valve pressure, turn clockwise to increase or counterclockwise to decrease until the pressure reaches 21Mpa.
 - Using a hex wrench, hold the main relief valve and meanwhile tighten the nut upon.
 - Repeat the Step 5 to verify the relief valve pressure.

7. Remove the pressure gauge.

Removing hydraulic pump

1. Tag, disconnect and plug the hydraulic hoses to the pump, and cap the fittings on the pump.
2. Loosen the bolts and carefully remove the pump from the machine.

NOTICE

It is important that, after replacing the hydraulic pump, the lift speed and drive speed of the machine must be reset to the factory defaults.

Function Valves

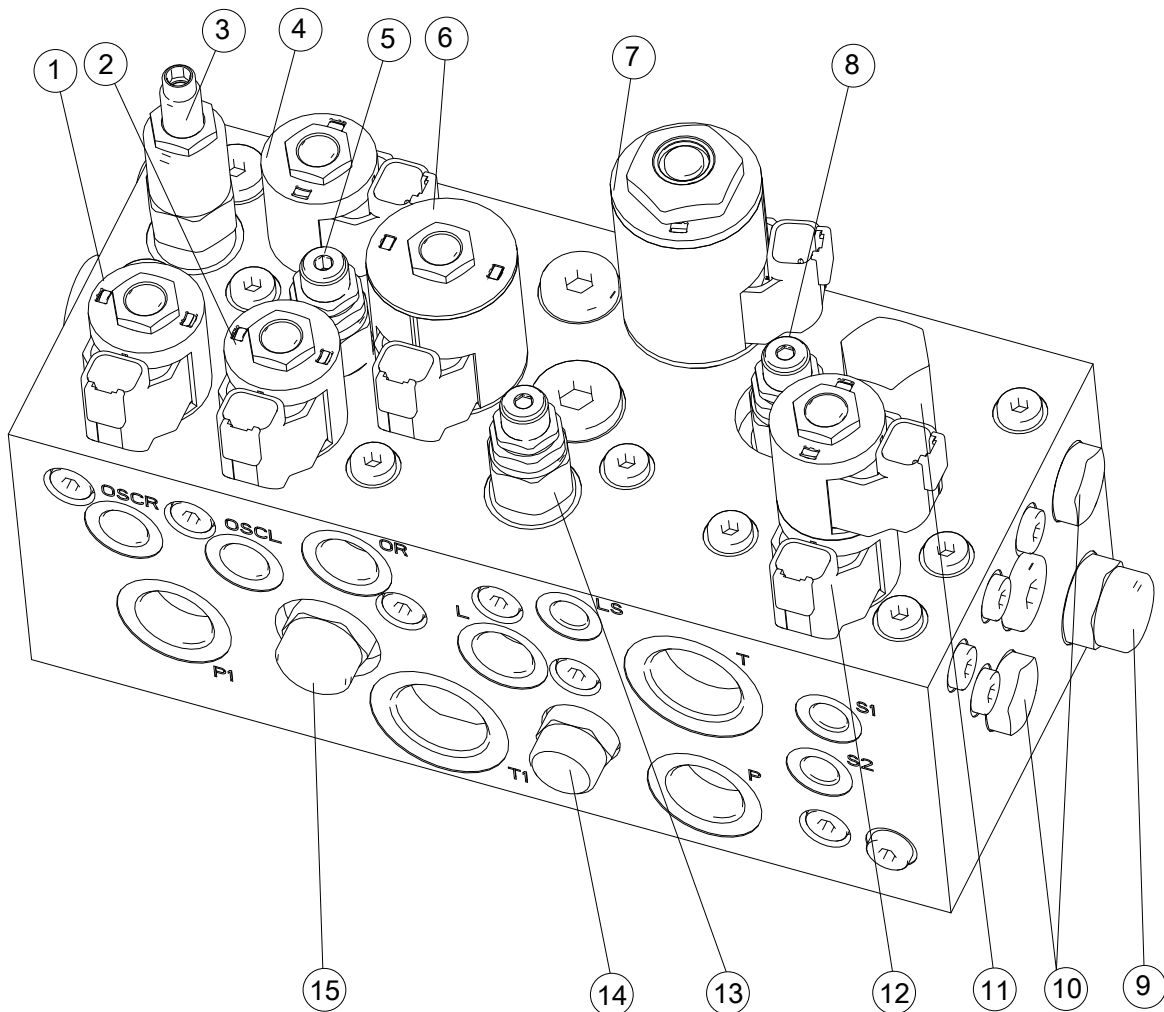

Figure 6-13 Scissor/platform control valve

Table 6-4

No.	Name	Function	Torque Value
1	2–position 3–way solenoid valve	To control right oscillation	27 Nm (20 ft-lb)
2	2–position 3–way solenoid valve	To control left oscillation	27 Nm (20 ft-lb)
3	Sequence valve	To control oscillate low pressure	34 Nm (25 ft-lb)
4	2–position 2–way solenoid valve	To control oscillate high pressure	27 Nm (20 ft-lb)
5	Relief valve	To relieve oscillate high pressure	32 Nm (24 ft-lb)
6	2–position 3–way valve	To control lift function	34 Nm (25 ft-lb)
7	Proportional flow valve	To control flow	47 Nm (35 ft-lb)
8	Relief valve	To relieve system pressure	60 Nm (44 ft-lb)
9	Flow valve	To control flow	34 Nm (25 ft-lb)
10	Check valve	To keep one-way flow	27 Nm (20 ft-lb)
11	Compensate valve	To discharge pressure	35 Nm (25.8 ft-lb)
12	3–position 5–way solenoid valve	To control steer direction	27 Nm (20 ft-lb)
13	Relief valve	To relieve lift pressure	60 Nm (44 ft-lb)
14	Flow valve	To control flow	27 Nm (20 ft-lb)
15	Flow valve	To control flow	34 Nm (25 ft-lb)

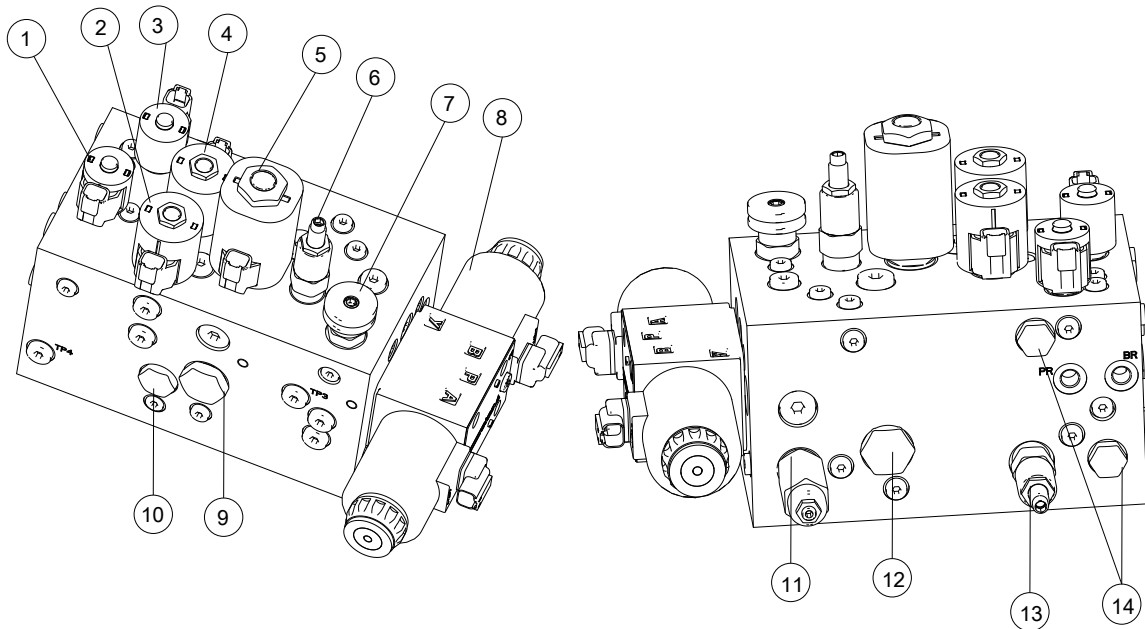

Figure 6-14 Drive control valve

Table 6-5

No.	Name	Function	Torque Value
1	2-position 3-way solenoid valve	To control brake releasing	27 Nm (20 ft-lb)
2	2-position 2-way solenoid valve	To idle front motor	34 Nm (25 ft-lb)
3	2-position 3-way solenoid valve	To control 2-speed drive	27 Nm (20 ft-lb)
4	2-position 2-way solenoid valve	To isolate front motor	34 Nm (25 ft-lb)
5	2-position 2-way solenoid valve	To control high speed drive	75 Nm (55.3 ft-lb)
6	2-way relief valve	To control drive relief	27 Nm (20 ft-lb)
7	Throttle valve	To cut off flow for towing	34 Nm (25 ft-lb)
8	3-position 4-way directional valve	To control drive direction	15 Nm (11 ft-lb)
9	Diverge/converge valve	To control flow	102 Nm (75 ft-lb)
10	Diverge/converge valve	To control flow	68 Nm (50 ft-lb)
11	Counterbalance valve	To remain load	65 Nm (48 ft-lb)
12	Diverge/converge valve	To control flow	102 Nm (75 ft-lb)
13	Pressure reducing valve	To control pressure	34 Nm (25 ft-lb)
14	Check valve	To keep one-way flow	43 Nm (32 ft-lb)

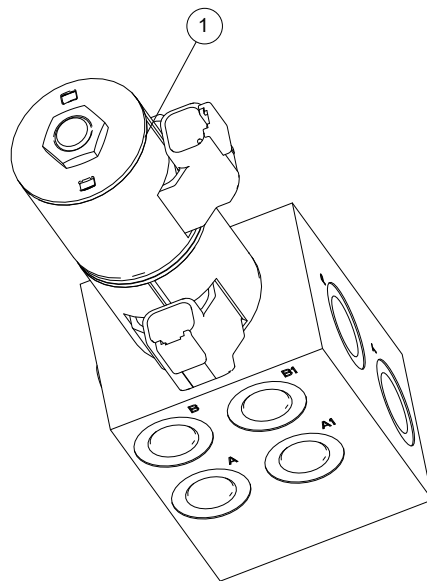

Figure 6-15 Outrigger directional valve

Table 6-6

No.	Name	Function	Torque Value
1	3-position 4-way solenoid valve	To control outrigger direction	34 Nm (25 ft-lb)

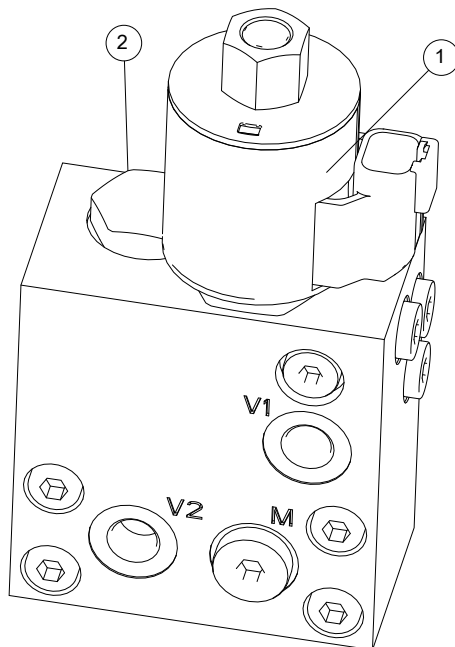

Figure 6-16 Outrigger solenoid valve

Table 6-7

No.	Name	Function	Torque Value
1	2-position 2-way solenoid valve	To control outrigger direction	27 Nm (20 ft-lb)
2	Check valve	To control outrigger direction	34 Nm (25 ft-lb)

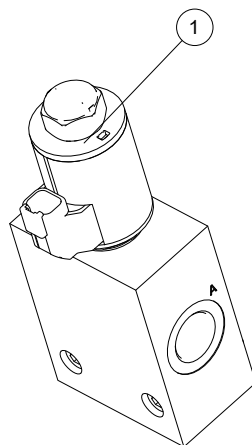

Figure 6-17 Generator control valve

Table 6-8

No.	Name	Function	Torque Value
1	Proportional flow valve	To control generator	47 Nm (35 ft-lb)

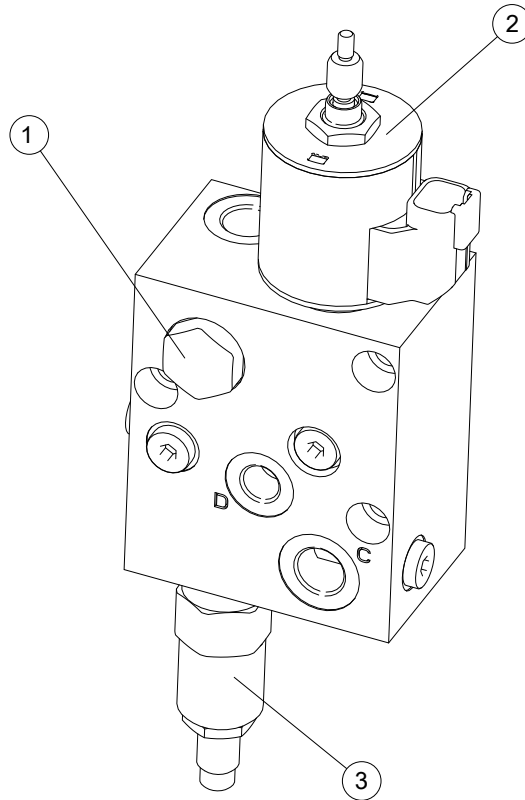

Figure 6-18 Lower lift cylinder control valve

Table 6-9

No.	Name	Function	Torque Value
1	Check valve	To keep one-way flow	43 Nm (31.7 ft-lb)
2	2-position 2-way solenoid valve	To control lowering	33.9 Nm (25 ft-lb)
3	Relief valve	To control lift pressure	60 Nm (44 ft-lb)

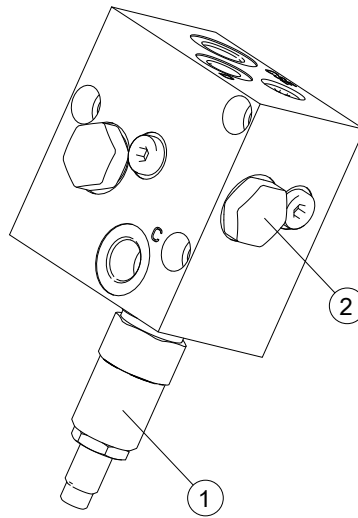

Figure 6-19 Upper lift cylinder control valve

Table 6-10

No.	Name	Function	Torque Value
1	Relief valve	To control lift pressure	43 Nm (31.7 ft-lb)
2	Check valve	To keep one-way flow	27 Nm (20 ft-lb)

WARNING

UNSAFE OPERATION HAZARDS

- Regulating the pressure improperly may result in machine damage, severe injury or death.
- Do not set the pressure higher or lower than specified.
- After the valve pressure is set, be sure to verify the value to root out any mistakes.
- The relief valve pressure of all machines has been factory set, do not tamper with the machine unless approved.

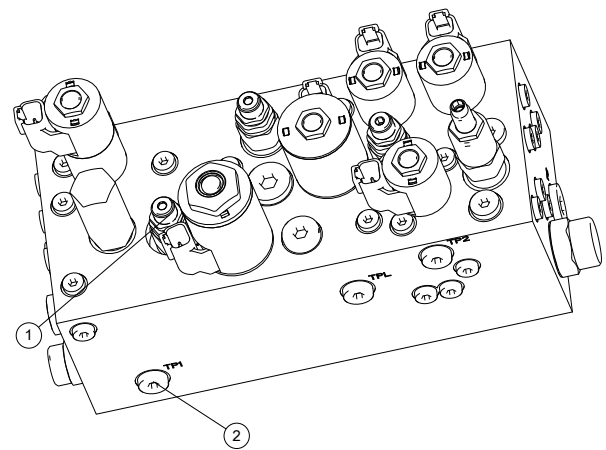

Figure 6-20

Table 6-11

No.	Name	Torque Value
1	Main relief valve	60 Nm (44.3 ft-lb)
2	Pressure test port #1	\

NOTICE

The machine must be in stowed position before performing this procedure.

Adjusting main relief valve pressure

1. Remove the plug of the pressure testing port 1# at the scissor/platform control valve, and install the pressure testing joint.
2. Connect the pressure gauge (range 40MPa) to the pressure testing joint.
3. Turn the Ground/Platform select switch on the ground controller to Platform.
4. Pull out the emergency stop buttons on both ground and platform controllers to ON position.
5. Fully steer the machine to the right/left and remain to hold the pressure, note down the readout on the gauge, the pressure should be 21MPa.
6. If the pressure value is not as specified, adjust the main relief valve pressure as follows :
 - Use an hex wrench to hold the oscillate high-pressure relief valve and loosen the nut.
 - Using a hex wrench, adjust the relief valve pressure, turn clockwise to increase or counterclockwise to decrease until the pressure reaches 21Mpa.
 - Using a hex wrench, hold the main relief valve and meanwhile tighten the nut upon.
 - Repeat the Step 5 to verify the relief valve pressure.
7. Remove the pressure gauge.

Adjusting lift relief valve pressure

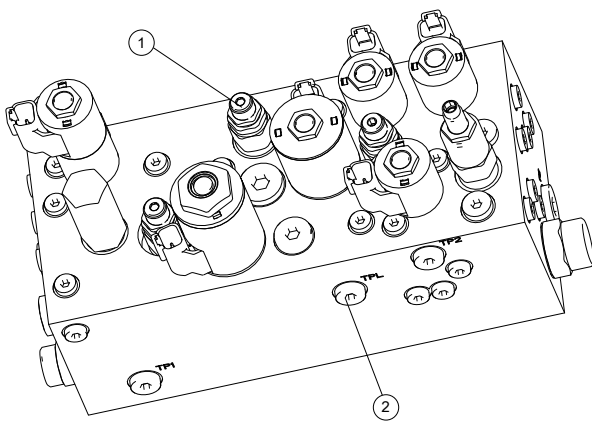

Figure 6-21

Table 6-12

No.	Name	Torque Value
1	Lift relief valve	60 Nm (44.3 ft-lb)
2	Pressure test port #2	\

Note : Before performing this procedure, please first remove the lift up limit switch from the chassis, and restore it to the original condition after adjusting the relief valve pressure.

1. Remove the plug of the pressure testing port 2# at the scissor/platform control valve, and install the pressure testing joint.
2. Connect the pressure gauge (range 40MPa) to the pressure testing joint.
3. Turn the Ground/Platform select switch on the ground controller to Platform.
4. Pull out the emergency stop buttons on both ground and platform controllers to ON position.
5. Operating from the ground, fully lift the platform and keep the position to hold the pressure, note down the readout on the gauge, the pressure should be 19.5MPa.
6. If the pressure value is not as specified, adjust the lift relief valve pressure as follows :
 - Use an hex wrench to hold the oscillate high-pressure relief valve and loosen the nut.
 - Using a hex wrench, adjust the relief valve pressure, turn clockwise to increase or counterclockwise to decrease until the pressure reaches 19.5Mpa.
 - Using a hex wrench, hold the lift relief valve and meanwhile tighten the nut upon.
 - Repeat the Step 5 to verify the relief valve pressure.
7. Remove the pressure gauge.

Adjusting oscillate relief valve pressure

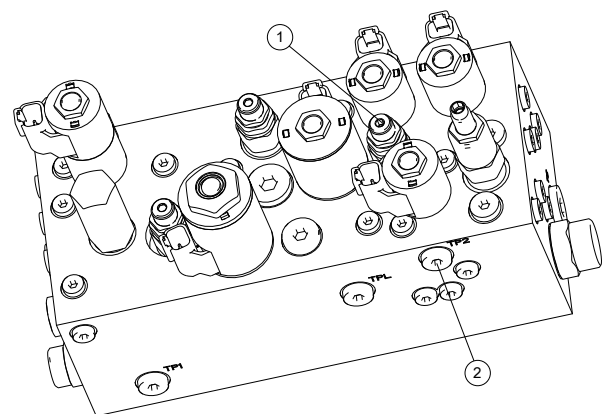

Figure 6-22

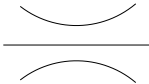

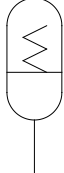

Table 6-13

No.	Name	Torque Value
1	Oscillate relief valve	32Nm (23.6 ft-lb)
2	Pressure test port #3	\

1. Remove the plug of the pressure testing port 3# at the scissor/platform control valve, and install the pressure testing joint.
2. Connect the pressure gauge (range 40MPa) to the pressure testing joint.
3. Unplug the oscillate enable coil Y95, left oscillate coil Y93 and right oscillate coil Y94.
4. Turn the Ground/Platform select switch on the ground controller to Platform.
5. Pull out the emergency stop buttons on both ground and platform controllers to ON position.
6. Drive the machine at low speed, note down the readout on the gauge, the pressure should be 20MPa.
7. If the pressure value is not as specified, adjust the lift relief valve pressure as follows :
 - Use an hex wrench to hold the oscillate high-pressure relief valve and loosen the nut.
 - Using a hex wrench, adjust the relief valve pressure, turn clockwise to increase or counterclockwise to decrease until the pressure reaches 19.5Mpa.
 - Using a hex wrench, hold the oscillate relief valve and meanwhile tighten the nut upon.
 - Repeat the Step 6 to verify the relief valve pressure.
8. Remove the pressure gauge.

Hydraulic Symbols

Table 6-14

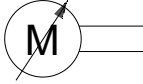
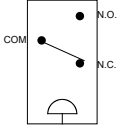
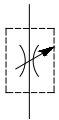
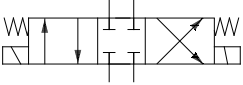
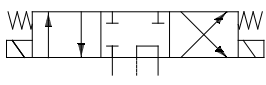
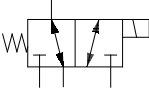
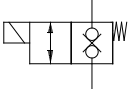
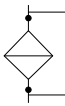
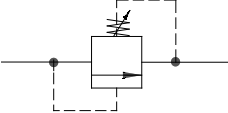
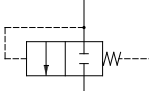
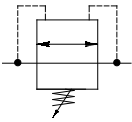
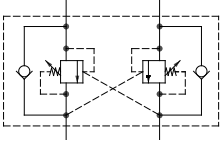
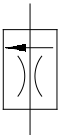
Symbol	Description	Symbol	Description
	Orifice		Check valve
	Dual-acting cylinder		Accumulator
	Gear pump		Prime mover (engine or motor)
	Pressure switch		Flow valve
	3-position 4-way directional valve		3-position 5-way directional valve
	2-position 3-way directional valve		2-position 2-way directional valve
	Filter with bypass valve		Relief valve
	Hydraulically controlled logic valve		Bidirectional relief valve
	Counterbalance valve		Flow valve

Hydraulic Schematic

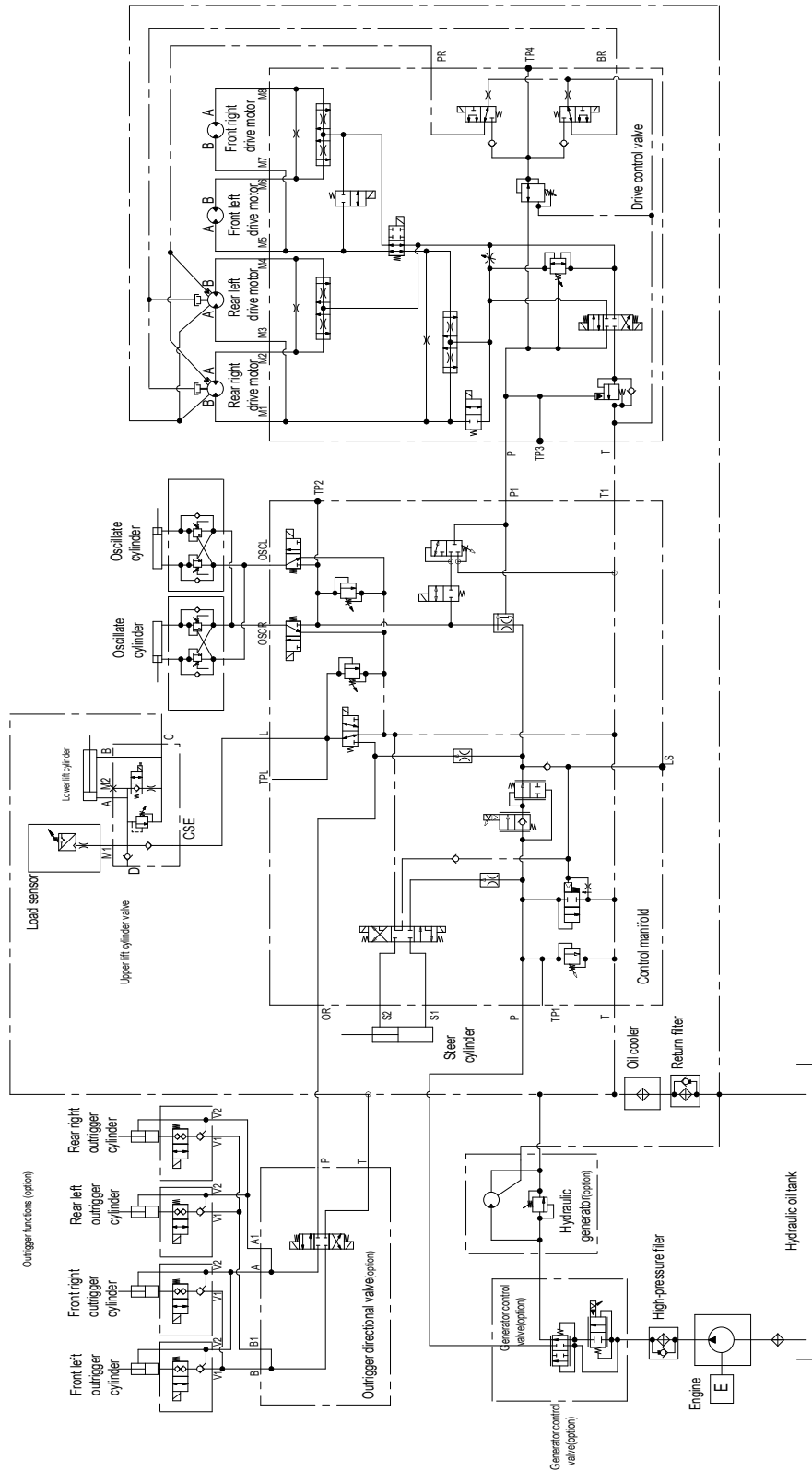

Figure 6-23 1018RD hydraulic schematic

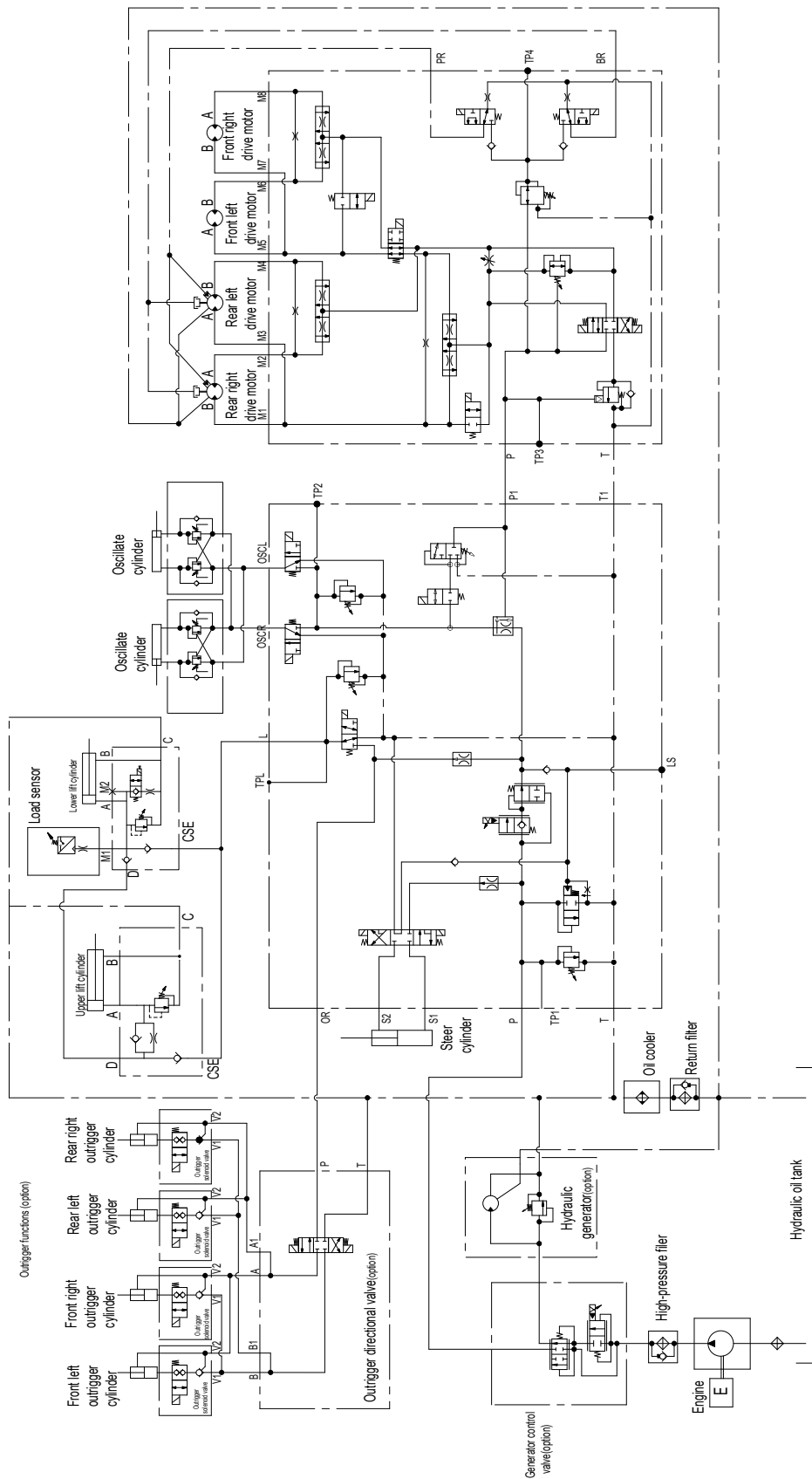

Figure 6-24 1218RD hydraulic schematic

ELECTRICAL SYSTEM

Fault Code Description

In case of machine malfunctions, please enter the fault display interface at the ground controller to check the fault codes.

Table 6-15

Fault Code	Description	Check
01	Internal ECU fault	Replace ECU
02	Platform ECU fault	Check wiring, if no problem, replace the ground and platform controllers respectively to determine where the fault is arised.
20	Chassis start switch fault	Check the switch and wiring
21	Chassis choke switch fault	Check the switch and wiring
22	Chassis up switch fault	Check the switch and wiring
23	Chassis lift switch fault	Check the switch and wiring
24	Chassis down switch fault	Check the switch and wiring
25	Left turn switch fault	Check the switch, replace platform controller if needed
26	Right turn switch fault	Check the switch, replace platform controller if needed
27	Drive enable switch fault	Check the switch, replace platform controller if needed
28	Off neutral drive joystick	Check the switch, replace platform controller if needed
31	Platform choke switch fault	Check the switch, replace platform controller if needed
32	Platform start switch fault	Check the switch, replace platform controller if needed
33	Left front outrigger switch fault	Check the switch, replace platform controller if needed
34	Right front outrigger switch fault	Check the switch, replace platform controller if needed
35	Left rear outrigger switch fault	Check the switch, replace platform controller if needed
36	Right rear outrigger switch fault	Check the switch, replace platform controller if needed
37	Automatic leveling switch fault	Check the switch, replace platform controller if needed
38	LF outrigger limit switch fault	Check limit switch and wiring
39	RF outrigger limit switch fault	Check limit switch and wiring
40	LR outrigger limit switch fault	Check limit switch and wiring
41	LR outrigger limit switch fault	Check limit switch and wiring
49	Drive coil 1 fault	Check wiring, replace solenoid valve if needed
50	Drive coil 2 fault	Check wiring, replace solenoid valve if needed
51	Drive coil 3 fault	Check wiring, replace solenoid valve if needed
52	Proportional coil fault	Check wiring, replace solenoid valve if needed

Fault Code	Description	Check
54	Up coil fault	Check wiring, replace solenoid valve if needed
55	Down coil fault	Check wiring, replace solenoid valve if needed
56	Right turn coil fault	Check wiring, replace solenoid valve if needed
57	Left turn coil fault	Check wiring, replace solenoid valve if needed
58	Brake coil fault	Check wiring, replace solenoid valve if needed
60	Forward coil 1 fault	Check wiring, replace solenoid valve if needed
61	Reverse coil 1 fault	Check wiring, replace solenoid valve if needed
66	Low oil pressure	Check wiring, replace pressure sensor if needed
67	High coolant temperature	Check wiring, replace temperature sensor if needed
68	Low ECU voltage	Check wiring and battery, replace battery if needed
69	Low engine RPM	Check engine and wiring
70	High engine RPM	Check engine and wiring
81	LF outrigger coil fault	Check wiring, replace solenoid valve if needed
82	LR outrigger coil fault	Check wiring, replace solenoid valve if needed
83	RF outrigger coil fault	Check wiring, replace solenoid valve if needed
84	Check wiring, replace solenoid valve if needed	Check wiring, replace solenoid valve if needed
85	Outrigger extension coil fault	Check wiring, replace solenoid valve if needed
86	Outrigger retraction coil fault	Check wiring, replace solenoid valve if needed
95	Machine type fault	Reset the machine type
OL	Platform overload	Check platform loads

Use and Maintenance of Battery

⚠ WARNING

BATTERY HAZARD



Always read and comply with the battery manufacturer's recommendations for procedures concerning proper battery use and maintenance.



Batteries contain sulfuric acid and generate explosive mixtures of hydrogen and oxygen gases. Keep any device that may cause sparks or flames away from the battery to prevent explosion.



Always wear protective glasses or goggles and protective clothing when working with batteries. You must follow the battery manufacturer's instructions on safety, maintenance and installation procedures.

Batteries contain sulfuric acid and generate explosive mixtures of hydrogen and oxygen gases. Keep any device that may cause sparks or flames away from the battery to prevent explosion.

Always wear protective glasses or goggles and protective clothing when working with batteries. You must follow the battery manufacturer's instructions on safety, maintenance and installation procedures.

This machine uses maintenance-free type of lead-acid battery. The requirements for its use and maintenance are as follows :

Preparation

- Before checking the fault, the operator must wear safety equipment, including insulating gloves, helmets and other necessary safety supplies and multimeters.

- Inspect the battery outer condition for problems such as battery deformation, damage of the positive and negative terminals, etc.
- Check and confirm the fault description and analyze the cause.

Charging

- Do not use an external charger.
- Charge using the correct AC input voltage indicated on the decal.
- Make sure the battery is connected before charging.
- Connect the battery charger to a grounded AC circuit.
- Charge the battery every time after using.

Maintenance

- While wearing proper hand and face protection, wipe the top and sides of the battery.
- Do not rinse or spray the battery pack with a water hose.
- Regularly check the cables and locknuts.
- Do not leave the battery in a discharged state during storage, as it will shorten the service life.



Cautions

- Because there is a risk of high voltage, do not touch non-insulated terminals or connectors.
- The battery terminal and related accessories contain lead and lead components. Wash your hands after handling them.

Electrical Symbols

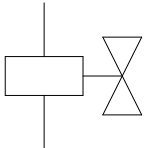
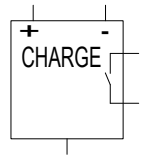
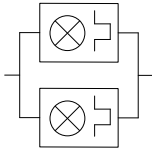
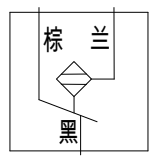
Table 6-16

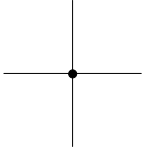
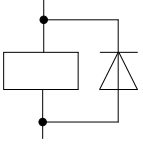
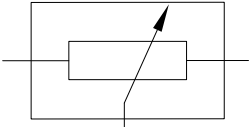
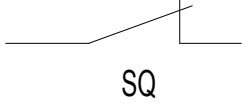
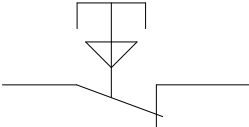
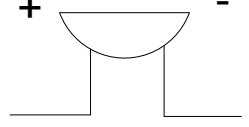
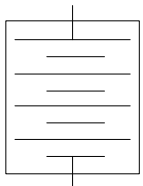
Symbol	Description
	Solenoid coil
	Charger
	Warning lamp
	Level switch

Symbol	Description
	Two lines connected
	Relay
	Sensor
	Limit switch
	Emergency stop button
	Buzzer
	Storage battery
	Fuse

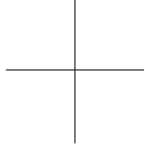
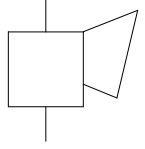
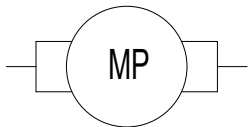
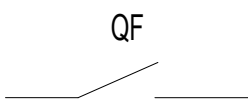
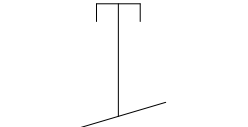
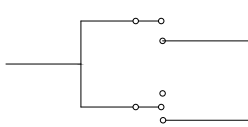
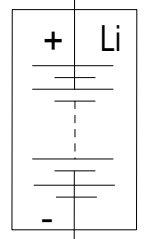
Symbol	Description
	Two lines non-connected
	Horn
	Pump control motor
	Power off button
	Button
	Key switch
	Lithium battery

Electrical Schematic

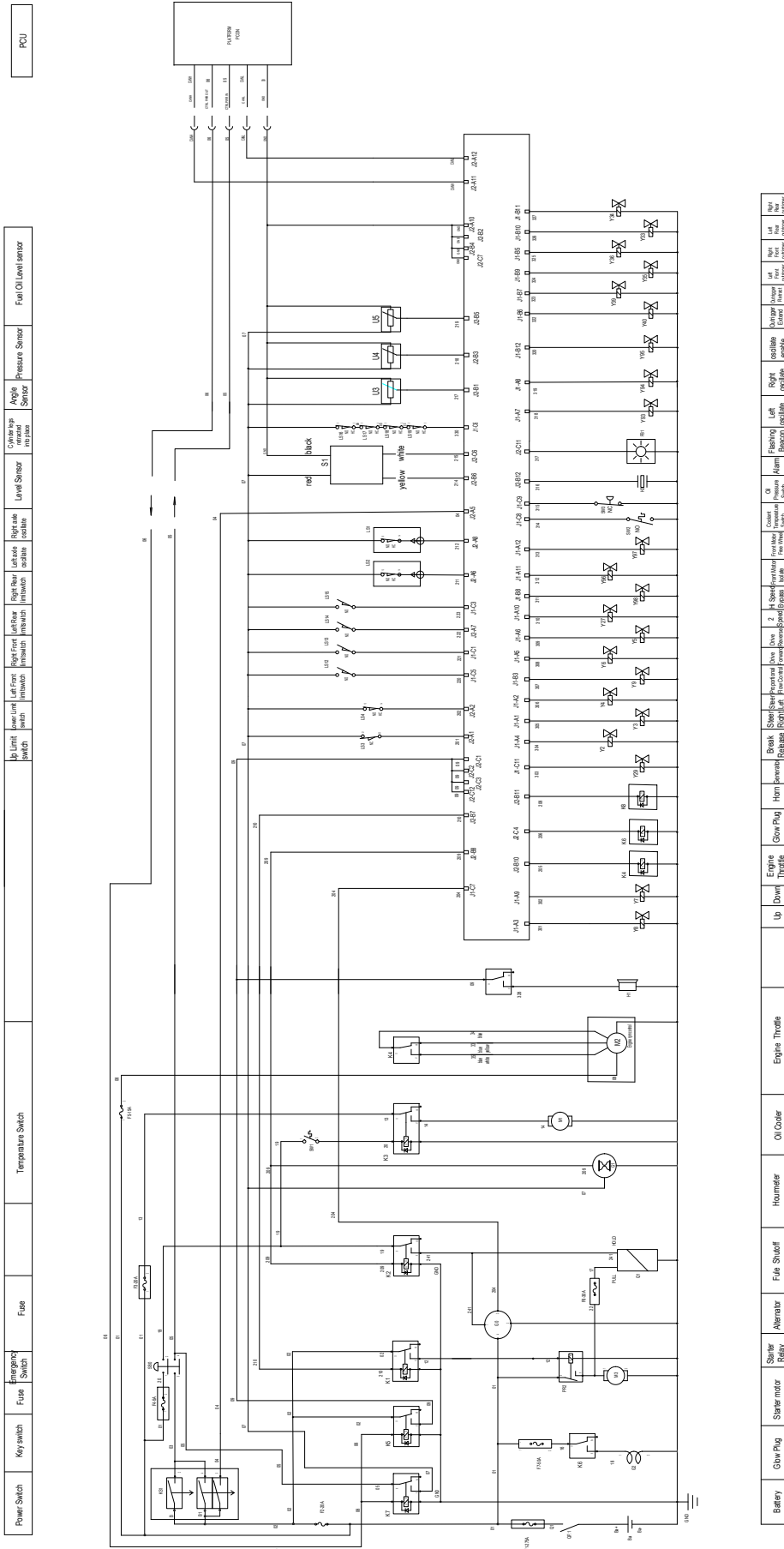

This Page Intentionally Left Blank

APPENDIX 1: PREPARE THE WORK RECORD BEFORE DELIVERY

PREPARE THE WORK RECORD BEFORE DELIVERY			
Model			
Serial No.			
Inspection Item	YES/Machine is in Good Condition	NO/Machine Has Damage or Malfunction	REPAIRED/Machine Has Been Repaired
Pre-operational Inspection			
Maintenance Procedure			
Functional Inspection			
Machine Buyer/ Renter			
Inspector Signature			
Inspector Title			
Inspector Company			
<p>NOTE:</p> <ol style="list-style-type: none"> 1. Prepare the machine before delivery, which includes performing a pre-delivery inspection, following maintenance procedures and performing functional inspections. 2. Use the table to record the results. After each section is complete, mark the appropriate box. 3. Record the inspection results. If any inspection results are "NO", the machine must be stopped and re-inspected after repair is completed and marked in the box marked "inspection". 			

This Page Intentionally Left Blank

APPENDIX 2: REPAIR & INSPECTION REPORT

REPAIR & INSPECTION REPORT				
Model				
Serial No.				
Checklist A Procedures				
Items	YES/Machine is in Good Condition	NO/Machine Has Damage or Malfunction	REPAIRED/ Machine Has Been Repaired	Problem Description
A-1 Inspect All Manuals				
A-2 Inspect All Decals				
A-3 Inspect Damaged, Loose or Lost Parts				
A-4 Inspect Hydraulic Oil Level				
A-5 Inspect Hydraulic Oil Leakage				
A-6 Inspect Fuel Level				
A-7 Inspect Fuel Leakage				
A-8 Inspect Engine Oil Level				
A-9 Inspect Coolant Level				
A-10 Inspect Engine Intake System				
A-11 Inspect Engine Belt				
A-12 Inspect Fuel Filter				
A-13 Inspect Cooling Fan				
A-14 Functional Tests				
A-15 Perform Maintenance after 30 Days				
Checklist B Procedures				
Items	YES/Machine is in Good Condition	NO/Machine Has Damage or Malfunction	REPAIRED/ Machine Has Been Repaired	Problem Description
B-1 Inspect Electrical Wiring				

REPAIR & INSPECTION REPORT				
B-2 Inspect Rim ,Tire and Fasteners				
B-3 Inspect Hydraulic Oil				
B-4 Inspect Cooling System				
B-5 Replace Fuel filter				
B-6 Inspect Air filter of Hydraulic Tank				
B-7 Replace High-Pressure Filter Element				
B-8 Replace Engine Air Filter Element				
B-9 Inspect the Battery				
B-10 Inspect Engine Exhaust System				
B-11 Inspect Drive Reducer Oil Level				
B-12 Test Oscillate Outriggers				
B-13 Test Drive Speed				
B-14 Test Tilt Protection System				
B-15 Test Brake Distance				
Checklist C Procedures				
Items	YES/Machine is in Good Condition	NO/Machine Has Damage or Malfunction	REPAIRED/ Machine Has Been Repaired	Problem Description
C-1 Replace Fuel Filter Element				
C-2 Replace Engine Oil				
C-3 Replace Engine Oil Filter				
C-4 Test Weighing System				
C-5 Test Secondary Lowering				
Checklist D Procedures				
Items	YES/Machine is in Good Condition	NO/Machine Has Damage or Malfunction	REPAIRED/ Machine Has Been Repaired	Problem Description

REPAIR & INSPECTION REPORT				
D-1 Replace Drive Reducer Gear Oil				
D-2 Inspect Scissor Arm Sliders				
D-3 Replace Hydraulic Oil				
D-4 Replace Hydraulic Tank Suction Filter				
D-5 Inspect Scissor Arm Bearing				
User				
Inspector Signature				
Inspector Date				
Inspector Title				
Inspector Company				
<p>Notes:</p> <ol style="list-style-type: none"> 1. The Repair & Inspection Report shall include the inspection table of each regular inspection. 2. Duplicate the Repair & Inspection Report for each inspection. Store the completed tables for 10 years or until the machine is no longer in use or as required by machine owner/company/custodian. 3. Use the following table to note the results. After each section is complete, mark the appropriate box. 4. Record the inspection results. If any inspection results are "NO", the machine must be stopped and re-inspected after repair is completed and marked in the box marked "inspection". Select the appropriate inspection procedure based on the inspection type. <p>Select the procedures as appropriate for the type of inspection.</p>				

Always for Better Access Solutions



Hunan Sinoboom Intelligent Equipment Co., Ltd.

No.128, East Jinzhou Avenue, Ningxiang High-tech Industrial Park, Changsha, Hunan, China

☎ 0086-0731-87116222 (Sales) & 0086-0731-87116333 (Service)

✉ sales@sinoboom.com

🏠 www.sinoboom.com

North American Subsidiary

Sinoboom North American LLC

310 Mason Creek Drive
unit #100
Katy, TX 77450, US
Tel: (281) 729-5425
E-mail: info@sinoboom.us

Europe Subsidiary

Sinoboom B.V.

Nikkelstraat 26, NL-2984 AM Ridderkerk,
The Netherlands
Tel: +31 180 225 666
E-mail: info@sinoboom.eu

Korea Subsidiary

Sinoboom Korea Co., Ltd.

95, Docheong-ro, Yeongtong-gu, Suwon-
si, Gyeonggi-do, Republic of Korea
Tel: 010-8310-8026
E-mail: ka1@sinoboom.com

Australia Subsidiary

Sinoboom Intelligent Equipment Pty Ltd.

50/358 Clarendon St, South Melbourne
VIC 3205, Australia
E-mail: au@sinoboom.com

Singapore Subsidiary

Star Access Solutions Pte. Ltd.

112 Robinson Road #03-01 Robinson 112
Singapore 068902

Poland Subsidiary

Sinoboom Poland sp. z o.o.

Ul. Bolesława Krzywoustego 74A
61-144 Poznań, Poland