

REPAIR MANUAL



SELF-PROPELLED SCISSOR PLATFORM

242 031 8240 - E 05.05 GB

ISO 9001
GROUPE
PINGUELY
HAULOTTE



ARTICULEES



MATS



TELESCOPIQUES



CISEAUX



TRACTEES

Haulotte 

L'ACCES A L'ESPACE

PINGUELY HAULOTTE • LA PERONNIERE - BP 9 - 42152 L'HORME • Tél. +33 (0) 4 77 29 24 24 • Fax SAV +33 (0) 4 77 31 28 11
email haulotte@haulotte.com • Web www.haulotte.com

Distribué par / Distributed by/ Distribuito da

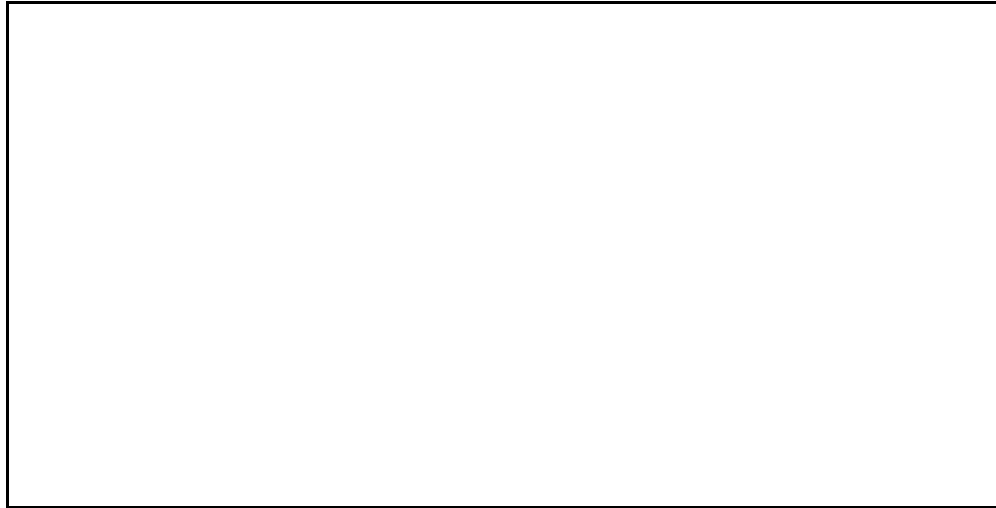

Haulotte France

Tél / Phone +33 (0)4 72 88 05 70
Fax / Fax +33 (0)4 72 88 01 43



**Centre Mondial Pièces de Rechange
Spare Parts International Centre**

Tél / Phone +33 (0)4 77 29 24 51
Fax / Fax +33 (0)4 77 29 98 88



Haulotte Hubarbeitsbühnen

Tél / Phone + 49 76 33 806 920
Fax / Fax + 49 76 33 806 82 18



Haulotte Portugal

Tél / Phone + 351 21 955 98 10
Fax / Fax + 351 21 995 98 19



Haulotte UK

Tél / Phone + 44 (0) 1952 292753
Fax / Fax² + 44 (0) 1952 292758



Haulotte U.S. Inc.

Main tool free 1-877-HAULOTTE
Service tool free 1-877-HAULOT-S



Haulotte Asia

Tél / Phone + 65 6536 3989
Fax / Fax + 65 6536 3969



Haulotte Netherlands BV

Tél / Phone + 31 162 670 707
Fax / Fax + 31 162 670 710



Haulotte Australia PTY Ltd

Tél / Phone + 61 3 9706 6787
Fax / Fax + 61 3 9706 6797



Haulotte Italia

Tél / Phone + 39 05 17 80 813
Fax / Fax + 39 05 16 05 33 28



Haulotte Do Brazil

Tél / Phone + 55 11 3026 9177
Fax / Fax + 55 3026 9178



Haulotte Scandinavia AB u.b.

Tél / Phone + 46 31 744 32 90
Fax / Fax + 46 31 744 32 99



Haulotte Iberica - Madrid

Tél / Phone + 34 91 656 97 77
Fax / Fax + 34 91 656 97 81



Haulotte Iberica - Sevilla

Tél / Phone + 34 95 493 44 75
Fax / Fax + 34 95 463 69 44

GENERAL

You have just taken delivery of your mobile elevating work platform

It will give you complete satisfaction if you follow the operating and maintenance instructions exactly.

The purpose of this instruction manual is to help you in this.

We stress the importance:

- of complying with the safety instructions relating to the machine itself, its use and its environment,
- of using it within the limits of its performances,
- of proper maintenance upon which its service life depends.

During and beyond the warranty period, our After-Sales Department is at your disposal for any service you might need.

Contact in this case our Local Agent or our Factory After-Sales Department, specifying the exact type of machine and its serial number.

When ordering consumables or spares, use this documentation, together with the «Spares» catalogue so as to receive original parts, the only guarantee of interchangeability and perfect operation.

This manual is supplied with the machine and is included on the delivery note.

REMINDER: You are reminded that our machines comply with the provisions of the «Machines Directive» 89/392/EEC of June 14th 1989 as amended by the directives 91/368/EEC of June 21st 1991, 93/44/EEC of June 14th 1993, 93/68/EEC of July 22nd 1993 and 89/336/EEC of May 3rd 1989, directive 2000/14/CE and directive EMC/89/336/CE.



Caution !

The technical data contained in this manual cannot involve our responsibility and we reserve the right to proceed with improvements or modifications without amending this manual.

SUMMARY

1 - GENERAL RECOMMENDATIONS - SAFETY	5
1.1 - GENERAL WARNING	5
1.1.1 - Manual	5
1.1.2 - Labels	5
1.1.3 - Safety.....	5
1.2 - GENERAL SAFETY RECOMMENDATIONS	6
1.2.1 - Operators.....	6
1.2.2 - Environment.....	6
1.2.3 - Using the machine	6
1.3 - RESIDUAL RISKS	7
1.3.1 - Risks of jolting - tipping over	7
1.3.2 - Electric risks.....	8
1.3.3 - Risks of explosion or burning.....	8
1.3.4 - Risks of collision	8
1.4 - VERIFICATIONS	8
1.4.1 - Regular checks	8
1.4.2 - Examination of device suitability	8
1.4.3 - Condition.....	8
1.5 - REPAIRS AND ADJUSTMENTS.....	9
1.6 - VERIFICATIONS BEFORE RESTARTING WORK	9
1.7 - BEAUFORT SCALE	9
2 - SPECIFICATION.....	11
2.1 - TECHNICAL CHARACTERISTICS	12
2.1.1 - Compact 8, Compact 8W technical data.....	12
2.1.2 - Compact 10N, Compact 10 technical data	13
2.1.3 - Compact 12 technical data	14
2.2 - SIZE.....	15
2.2.1 - Compact 8 size	15
2.2.2 - Compact 8W size.....	15

2.2.3 - Compact 10N size	15
2.2.4 - Compact 10 size.....	16
2.2.5 - Compact 12 size.....	16
2.3 - TIGHTENING TORQUE	17
2.3.1 - Tightening torque for large thread screws.....	17
2.3.2 - Tightening torque for fine thread screws.....	17
2.3.3 - Recommended torques	17
2.4 - PRESSURE TABLE (IN BARS)	18
2.5 - ADJUSTEMENT TIMES TABLE	18
3 - WIRING DIAGRAMS	19
3.1 - WIRING DIAGRAM E 591A (PRESSURE SWITCH VERSION).....	20
3.1.1 - Electric components : pressure switch version	21
3.2 - WIRING DIAGRAM E591A : WEIGHING CARD VERSION	22
3.2.1 - Electric components : weighing card version	23
4 - ELECTRIC COMPONENTS' DESCRIPTION.....	25
4.1 - CHASSIS CONTROL POST	25
4.1.1 - Switches (E591a - Pressure switch version).....	25
4.1.2 - Fuses and motors.....	26
4.2 - PLATFORM CONTROL POST EQUIPMENT.....	26
4.3 - SOLENOID VALVES.....	26
4.4 - END OF TRAVEL SWITCHES CHART	27
4.5 - SERIAL CARD	27
4.5.1 - Serial card initialization.....	28
4.6 - MDI.....	28
4.7 - USING THE ON-BOARD CHARGER	29
4.7.1 - Characteristics.....	29
4.7.2 - Starting charging	29
4.7.3 - Holding charge	29
4.7.4 - Interrupting charging	29
4.7.5 - Precautions in use.....	29

4.8 -	CHOPPER	30
4.8.1 -	Terminal-wire connections chart	30
5 -	HYDRAULIC DIAGRAMS	31
5.1 -	HYDRAULIC DIAGRAM FOR COMPACT 8, 8W, 10N AND 10 MODELS (B16187A)	31
5.1.1 -	List of components	31
5.2 -	HYDRAULIC INSTALLATION DIAGRAM FOR COMPACT 8 (A14562B)	32
5.2.1 -	Components listed in diagram A14652b	33
5.3 -	HYDRAULIC INSTALLATION DIAGRAM FOR COMPACT 8W, 10N AND 10 (A14563B)	34
5.3.1 -	Components listed in diagram A14653b	35
5.4 -	HYDRAULIC DIAGRAM FOR COMPACT 12 MODEL (B16188A)	36
5.4.1 -	List of components	36
5.5 -	HYDRAULIC INSTALLATION DIAGRAM FOR COMPACT 12 (A14564C)	37
5.5.1 -	Components listed in diagram A14564c	38
6 -	DESCRIPTION OF THE HYDRAULIC CIRCUIT	39
6.1 -	HYDRAULIC BLOCK'S COMPONENTS	39
6.2 -	MK4 HYDRAULIC BLOCK SPECIFICATIONS	41
6.2.1 -	List of components (Page 5 of 5 in S5625)	45
6.3 -	HYDRAULIC FUNCTIONING	45
6.3.1 -	Operating equation	45
6.3.2 -	Solenoid valves' functioning	46
6.3.3 -	Direction of travel and anti-rolling selection	46
6.3.4 -	Speed selection	47
6.3.5 -	Steering functioning	50
7 -	MAINTENANCE	51
7.1 -	GENERAL RECOMMENDATIONS	51
7.2 -	MAINTENANCE DEVICE	51
7.3 -	ELECTRICITY SUPPLY	52
7.4 -	MAINTENANCE PLAN	53

7.4.1 - Consumables	53
7.4.2 - Maintenance diagram.....	54
7.5 - OPERATIONS.....	55
7.5.1 - Summary table	55
7.6 - PRESENCE OF LABELS	56
7.7 - PRESENCE OF MANUALS	56
8 - PREVENTIVE MAINTENANCE SHEETS	57
8 - OPERATING INCIDENTS	67
8.1 - TABLE OF INCIDENTS	67
8.1.1 - General operation.....	67
8.1.2 - Platform lifting system	68
8.1.3 - Travel system	69
8.1.4 - Steering system.....	69
8.1.5 - List of MDI codes.....	70
8.2 - FAILURE DETECTION FLOW CHARTS	73
9 - CORRECTIVE MAINTENANCE PROCEDURES.....	113

1 - GENERAL RECOMMENDATIONS - SAFETY

1.1 - GENERAL WARNING



1.1.1 - Manual

This manual aims to help maintenance personnel service and repair the machine. It cannot, however, replace the basic training required by any person working on the site equipment.

The site manager must inform operators of the recommendations in the instruction manual. He is also responsible for application of current "user regulations" in the country of use.

Before operating on the machine, it is essential to be familiar with all the recommendations in this manual and the user manual to ensure personnel and equipment safety.

1.1.2 - Labels

Potential dangers and recommendations for the machine are indicated on labels and plates. Read the instructions on them.

All labels conform to the following colour code:

- Red indicates a potentially fatal danger.
- Orange indicates a danger that may cause serious injury.
- Yellow indicates a danger that may cause material damage or slight injury.



Maintenance personnel must ensure that these labels and plates are in good conditions and keep them legible. Spare labels and plates can be supplied by the manufacturer on request.

1.1.3 - Safety

Ensure that any person entrusted with the machine is take the safety measures implied by its use.

Avoid any working mode that may affect safety. Any use that does not comply with the recommendations may generate risks and damage to people and equipment.

After intervention, maintenance personnel must check that the operator manual is present. This must be kept by the user throughout the machine's service life, even if it is loaned, rented or sold.

Ensure that all the plates or labels related to safety and danger are complete and legible.



Caution!

To attract the reader's attention, instructions are indicated by this standardised sign.

1.2 - GENERAL SAFETY RECOMMENDATIONS

1.2.1 - Operators

Operators must be aged 18 or over and hold an operating permit issued by the employer after verification of medical aptitude and the practical platform operation test.



Caution!

Only trained operators may use Haulotte self-propelled platforms.

There must be at least two operators present, so that one of them can:

- intervene rapidly if necessary,
- take over the controls in the case of accident or breakdown,
- monitor and prevent machines or people from circulating around the platform,
- guide the platform operator if necessary.

1.2.2 - Environment

Never use the machine:

- On soft, unstable or cluttered floors.
- On a floor with a tilt greater than the allowed limit.
- With a windspeed above the permitted level. In case of outdoor use, check that windspeed is lower or equal to the permitted level using an anemometer.
- Near electric lines (find out about minimum distances according to current). In temperatures of less than -15°C (in particular, in cold rooms); consult our service department if work is required in conditions below -15°C .
- In an explosive atmosphere.
- In an incorrectly ventilated area, as exhaust fumes are toxic.
- During storms (risk of being struck by lightning).
- At night if the machine is not equipped with an optional light.
- In the presence of intense electromagnetic fields (radar, mobile and high current).

DO NOT DRIVE ON THE PUBLIC HIGHWAY.

1.2.3 - Using the machine

It is important to ensure that in normal use, i.e. platform operation, the platform station selection key remains in the the platform position to enable control of the machine from the platform. If a problem occurs on the platform, a person present and trained in emergency/standby manoeuvres can help by putting the key in the ground control position.

Never use the machine with:

- a load greater than the nominal load,
- more people than the authorised number,
- lateral force in the platform greater than the level permitted,
- wind speed higher than the permitted level.



**Caution!**

**Never use the platform as a crane, goods lift or elevator.
Never use the platform or tow or haul.**

To avoid all risk of serious fall, operators must respect the following instructions:

- Hold the hand rails firmly when climbing onto or operating the platform.
- Wipe any traces of oil or grease off the steps, floor and hand rails.
- Wear protective clothing suited to working conditions and current local legislation, in particular when working in hazardous areas.
- Do not disable the safety system end of stroke contactors.
- Avoid contact with fixed or mobile obstacles.
- Do not increase working height by using ladders or other accessories.
- Never use the hand rails as a means of access for getting onto and off the platform (use the steps provided on the machine).
- Never climb on the hand rails when the platform is raised.
- Never drive the platform at high speed in narrow or cluttered areas.
- Never use the machine without installing the platform protective bar or closing the safety barrier.
- Never climb on the covers.

To avoid risks of tipping over, operators must respect the following instructions:

- Do not disable the safety system end of stroke contactors.
- Avoid moving the steering control levers in the opposite direction, without stopping in the "O" position (to stop during a travel manoeuvre, move the manipulator lever gradually).
- Respect maximum load and maximum number of people authorised on the platform.
- Distribute the load evenly and place in the centre of the platform if possible.
- Check that the floor resists the pressure and load per wheel.
- Avoid contact with fixed or mobile obstacles.
- Do not drive the platform at high speed in narrow or cluttered areas.
- Do not drive the platform in reverse (inadequate visibility).
- Do not use the machine if the platform is cluttered.
- Do not use the machine with equipment or objects hanging from the hand rails.
- Do not use the machine with elements that may increase the wind load (e.g. panels).
- Do not perform machine maintenance operations when the machine is raised without setting up the required safety means (gantry crane, crane).
- Make daily checks and monitor proper operation during periods of use.
- Preserve the machine from any uncontrolled operation when it is not in service.

NB: *Do not tow the platform (it is not designed to be towed and must be transported on a trailer).*

1.3 - RESIDUAL RISKS

1.3.1 - Risks of jolting - tipping over

The risks of jolting or tipping over are high in the following situations:

- sudden action on the control levers,
- platform overload,
- uneven floor (pay attention to thaw periods in winter),
- gusts of wind,
- contact with obstacles on the ground or in the air,
- working on quays, pavements, etc.

Allow sufficient stopping distances:

- 3 metres at high speed,
- 1 metre at low speed.

**Caution!**

If the machine has a 220 V plug, with max. 16A, the extension must be connected to a mains socket protected by a 30mA differential circuit breaker.

1.3.2 - Electric risks

Electric risks are high in the following situations:

- contact with a live line,
- use during stormy weather.

1.3.3 - Risks of explosion or burning

The risks of explosion or burning are high in the following situations:

- work in an explosive or inflammable atmosphere,
- filling the fuel tank near a naked flame,
- contact with the hot parts of the motor,
- use of a machine with hydraulic leaks.

1.3.4 - Risks of collision

- Risks of crushing people present in the machine's movement area (travel or when manoeuvring the equipment).
- The operator must assess any overhead risks before use.

1.4 - VERIFICATIONS

Comply with current national legislation in the country of use.

In FRANCE: Order dated June 9th 1993 + circular DRT 93-22 dated September 1993, specifying:

1.4.1 - Regular checks

The devices must be regularly inspected every 6 months to detect any defect liable to cause an accident.

These inspections are to be carried out by an organisation or person specially appointed by the site manager and under his responsibility (company personnel or otherwise) Articles R 233-5 and R 233-11 of the Labour Code.

The result of these inspections is recorded in a safety register updated by the site manager and constantly available to the Works Inspector and the company's safety committee, if any, and the list of specially appointed personnel (Article R 233-5 of the Labour Code).

NB: This register can be obtained from professional organisations and for some, from the OPPBTP or private prevention organisations.

The appointed people must be experienced in the field of risk prevention (Article R 233-11 of decree no. 93-41).

It is forbidden to allow anyone to perform any checks during machine operation (Article R 233-11 of the Labour Code).

1.4.2 - Examination of device suitability

The manager of the site on which the equipment is used must ensure that the machine is suitable, i.e. appropriate to the work to be carried out safely and that it is used in accordance with the instruction manual. Moreover, the French order, dated June 9th 1993, refers to problems associated with rental, examination of the condition, verifications before starting work after repair, and conditions of static test coefficient 1.25 and dynamic test coefficient 1.1. All responsible users should find out about and respect the requirements of this decree.

1.4.3 - Condition

Detect any deterioration liable to cause dangerous situations (safety devices, load limiters, tilt detector, cylinder leaks, deformation, weld condition, tightness of bolts, hoses and electric connections, tyre condition, excessive mechanical play).

NB: *In the case of rental, responsible users of the rented machine must examine the condition and check suitability. They must check with the rental company that the general regular checks and checks before starting work have been performed.*

1.5 - REPAIRS AND ADJUSTMENTS

Major repairs, interventions or adjustments on the safety systems or elements (concerning mechanical, hydraulic and electric systems) must be carried out by PINGUELY-HAULOTTE personnel or personnel working on behalf of PINGUELY-HAULOTTE, who will only use original spare parts.

Any modification outside PINGUELY-HAULOTTE's control is unauthorised.

The manufacturer is not responsible if original spare parts are not used or if the work specified above is not performed by PINGUELY-HAULOTTE approved personnel.

1.6 - VERIFICATIONS BEFORE RESTARTING WORK

To be performed after:

- major dismantling-reassembly operations,
- repair of the machine's essential devices,
- any accident caused by failure of an essential device.

A suitability examination, examination of the condition, static test and dynamic test must all be carried out (see coefficient paragraph 1.4.2, page 8).

1.7 - BEAUFORT SCALE

The Beaufort Scale of wind force is accepted internationally and is used when communicating weather conditions. It consists of number 0 - 17, each representing a certain strength or velocity of wind at 10m (33 ft) above ground level in the open.

Description of Wind	Specifications for use on land	MPH	m/s
0 Calm	Calm; smoke rises vertically.	0-1	0-0.2
1 Light Air	Direction of wind shown by smoke.	1-5	0.3-1.5
2 Light Breeze	Wind felt on face; leaves rustle; ordinary vanes moved by wind.	6-11	1.6-3.3
3 Gentle Breeze	Leaves and small twigs in constant motion; wind extends light flag.	12-19	3.4-5.4
4 Moderate Breeze	Raises dust and loose paper; small Branches are moved.	20-28	5.5-7.9
5 Fresh Breeze	Small trees in leaf begin to sway; crested wavelets form on inland waterways.	29-38	8.0-10.7
6 Strong Breeze	Large branches in motion; whistling heard in telephone wires; umbrellas used with difficulty.	39-49	10.8-13.8
7 Near Gale	Whole trees in motion; inconvenience felt when walking against wind.	50-61	13.9-17.1
8 Gale	Breaks twigs off trees; generally impedes progress.	62-74	17.2-20.7
9 Strong Gale	Slight structural damage occurs (chimney pots and slates removed).	75-88	20.8-24.4

2 - SPECIFICATION

Self-propelled platforms, models Compact 8, 8W, 10, 10N and 12, are designed for any overhead work within the limits of their characteristics (see paragraph 2.1, page 12) and within the respect of all safety instructions specific to the equipment and places of use.

The main operating station is on the platform.

The other operating station away from the platform is a standby or emergency station.

REMINDER: For any information, intervention of spare part requests, please specify the machine type and serial number.

2.1 - TECHNICAL CHARACTERISTICS
2.1.1 - Compact 8, Compact 8W technical data

Designation	Compact 8	Compact 8W
Load (indoor use)	350 kg, including 2 persons	450 kg, including 3 persons
Load (outdoor use)	120 kg, including 1 person	450 kg, including 3 persons
Lateral manual force (indoor use)	40 daN	40 daN
Lateral manual force (outdoor use)	20 daN	20 daN
Max. wind speed (indoor use)	0 mph	0 mph
Max. wind speed (outdoor use)	27.96 mph	27.96 mph
Floor height	6.18 m	6.27 m
Working height	8.18 m	8.27 m
Length folded	2.31 m	
Length folded with steps	2.48 m	
Overall width	0.81 m	1.20 m
Height folded (guard rail)	1.99 m	2.14 m
Height folded (platform)	0.87 m	1.02 m
Wheelbase	1.86 m	
Ground clearance	130 mm	
Ground clearance, anti-tipping over device deployed	25 mm	
Platform dimensions	2.3 m x 0.8 m	2.3 m x 1.2 m
Extension dimensions	0.92 m	
Extension capacity	150 Kg	
Travel speed, machine folded	0/2.17 mph	
Travel speed, machine raised	0/0.62 mph	
Inside turning radius	0,34 m	0.2 m
Outside turning radius	2,38 m	2.5 m
Max. travel slope	25%	23%
Max. permissible tilt	2°	3°
Hydraulic reservoir	25 l	
Total weight	1730 Kg	1950 Kg
Max. load on one wheel	864 daN	1290 daN
Max. ground pressure	13.2 daN/cm ²	17.3 daN/cm ²
Number of drive wheels	2	2
Number of steered wheels	2	2
Tyres	non-marking ; solid rubber	
Diameter of wheels	380 mm	
Freewheeling	YES	
Movements	proportional controls	
Batteries	24 V - 180 Amp/h C5	24 V - 250 Amp/h C5
General hydraulic pressure	200 bars	
Travel	200 bars	
Steering	150 bars	
Lifting	165 bars	
Raising time	37 s	44 s
Lowering time	41 s	56 s
EC standards	YES	

2.1.2 - Compact 10N, Compact 10 technical data

<i>Designation</i>	<i>Compact 10N</i>	<i>Compact 10</i>
Load (indoor use)	230 kg including 2 persons	450 kg including 3 persons
Load (outdoor use)	forbidden	120 kg including 1 person
Lateral manual force (indoor use)	40 daN	40 daN
Lateral manual force (outdoor use)	forbidden	20 daN
Max. wind speed (indoor use)	0 mph	0 mph
Max. wind speed (outdoor use)	forbidden	45 km/h
Floor height	8.08 m	8.14 m
Working height	10.08 m	10.14 m
Length folded	2.31 m	
Length folded with steps	2.48 m	
Overall width	1.20 m	
Height folded (guard rail)	2.18 m	2.26 m
Height folded (platform)	1.07 m	1.14 m
Wheelbase	1.86 m	
Ground clearance	130 mm	
Ground clearance, anti-tipping over device deployed	25 mm	
Platform dimensions	2.3 m x 0.8 m	2.3 m x 1.2 m
Extension dimensions	0.92 m	
Extension capacity	120 Kg	150 kg
Travel speed, machine folded	0/2.17 mph (variable)	
Travel speed, machine raised	0.62 mph	
Inside turning radius	0,34 m	0,2 m
Outside turning radius	2.38 m	2.5 m
Max. travel slope	23%	
Max. permissible tilt	2°	3°
Hydraulic reservoir	25 l	
Total weight	2160 Kg	2330 Kg
Max. load on one wheel	1048 daN	1473 daN
Max. ground pressure	15,96 daN/cm ²	17.7 daN/cm ²
Number of drive wheels	2	2
Number of steered wheels	2	2
Tyres	solid rubber 38x13x5 cm	
Diameter of wheels	380 mm	
Freewheeling	YES	
Movements	proportional controls	
Batteries	24 V - 180 Amp/h C5	24 V - 250 Amp/h C5
General hydraulic pressure	220 bars	
Travel	220 bars	
Steering	150 bars	
Lifting	165 bars	
Raising time	51 s	
Lowering time	42 s	
EC standards	YES	

2.1.3 - Compact 12 technical data

<i>Description</i>	<i>Compact 12</i>
Load (indoor use)	300 kg including 3 persons
Load (outdoor use)	120 kg including 1 person
Manual lateral force (indoor use)	40 daN
Manual lateral force (outdoor use)	20 daN
Maximum wind speed (indoor use)	0 mph
Maximum wind speed (outdoor use)	27.96 mph
Floor height	10 m
Working height	12 m
Folded length	2.31 m
Folded length with steps	2.48 m
Overall width	1.20 m
Folded height (hand rails)	2.38 m
Folded height (platform)	1.26 m
Wheel base	1.86 m
Floor clearance	130 mm
Floor clearance with pothole system extended	25 mm
Platform dimension	2.3 m x 1.2 m
Extension dimension	0.92 m
Extension capacity	150 kg
Travel speed, machine folded	0/2.17 mph (variable)
Travel speed, machine raised	0.62 mph
Interior turning radius	0,2 m
Exterior turning radius	2.5 m
Maximum slope during travel	23%
Maximum tilt permitted	3°
Hydraulic tank	25 l
Total mass	2630 kg
Max. load on one wheel	1784 daN
Maximum pressure on the floor	19.3 daN/cm ²
Number of drive wheels	2
Number of steering wheels	2
Tyres	Solid rubber 38x13x5 cm
Wheel diameter	380 mm
Freewheel	YES
Movements	Proportional controls
Batteries	24 V - 250 Amp/h C5
General hydraulic pressure	240 bars
Travel	240 bars
Steering	150 bars
Lifting	155 bars
Raising time	85 s
Lowering time	50s
CE standards	YES

2.2 - SIZE

2.2.1 - Compact 8 size

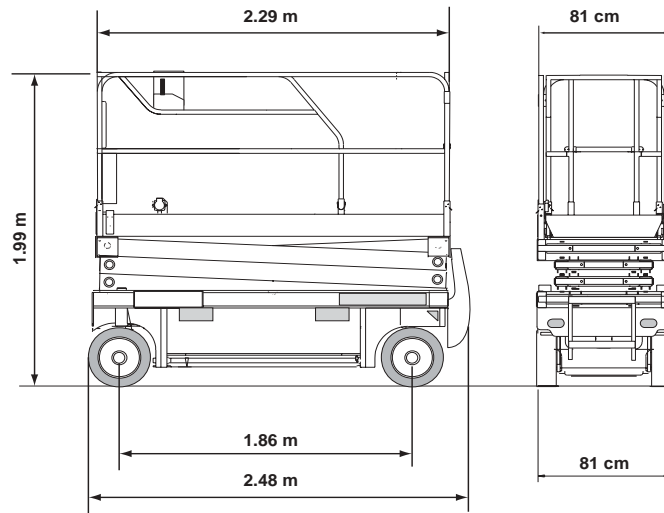

2.2.2 - Compact 8W size

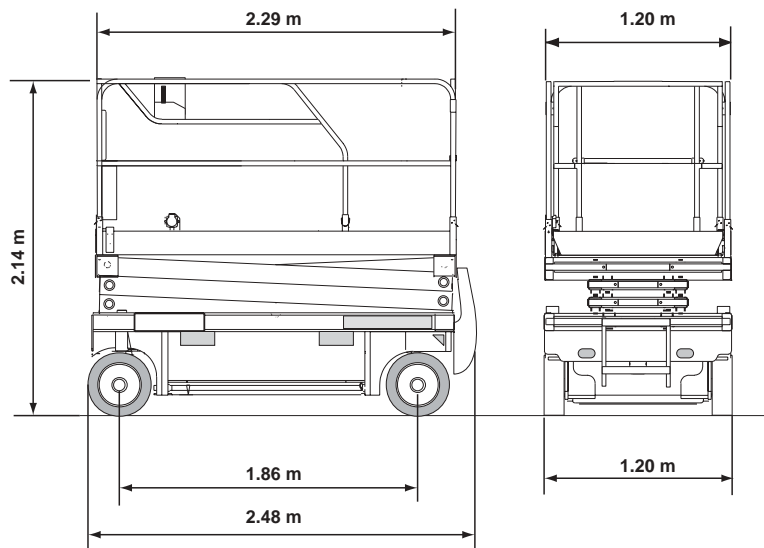

2.2.3 - Compact 10N size

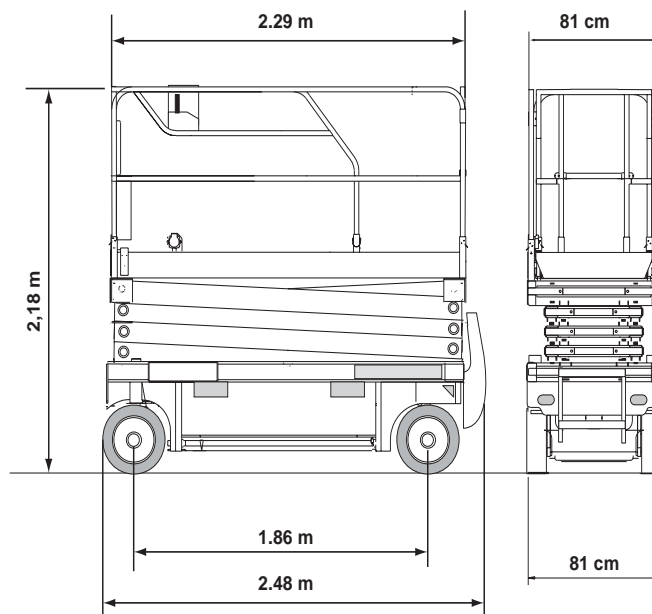

2.2.4 - Compact 10 size

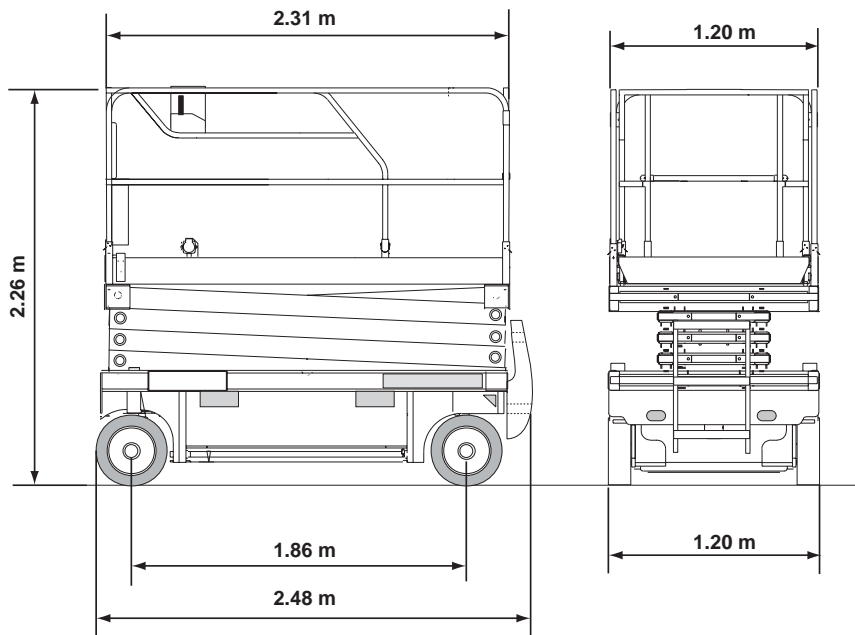

2.2.5 - Compact 12 size

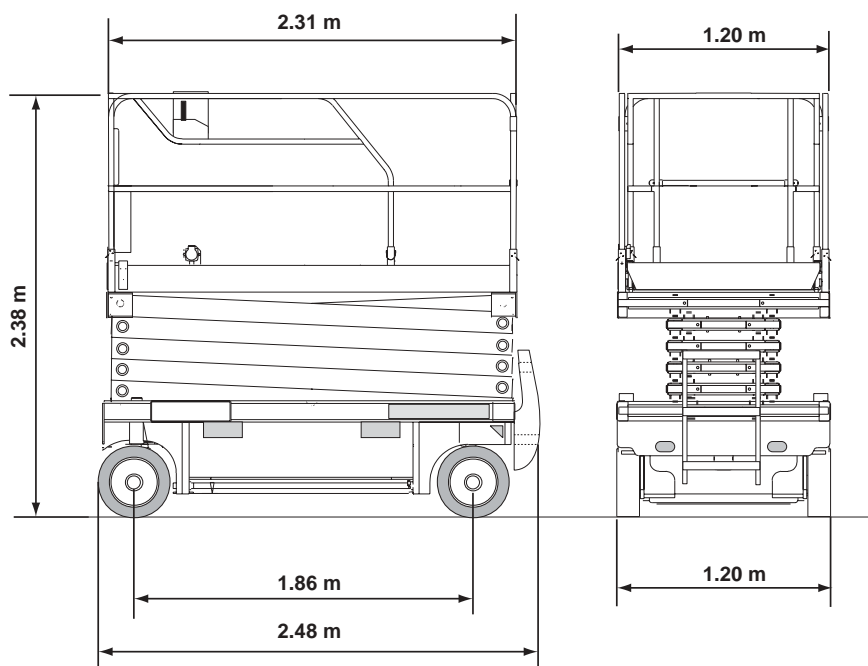

2.3 - TIGHTENING TORQUE**2.3.1 - Tightening torque for large thread screws**

<i>Nominal diameter</i>	<i>Tightening torque in N.M</i>		
	8.8	10.9	12.9
M 6*1	9 to 11	13 to 14	15 to 17
M 7*1	15 to 19	21 to 24	26 to 28
M 8*1.25	22 to 27	31 to 34	37 to 41
M 10*1.5	43 to 45	61 to 67	73 to 81
M 12*1.75	75 to 94	110 to 120	130 to 140
M 14*2	120 to 150	170 to 190	200 to 220
M 16*2	190 to 230	260 to 290	320 to 350
M 18*2.5	260 to 320	360 to 400	440 to 480
M 20*2.5	370 to 450	520 to 570	620 to 680
M 22*2.5	500 to 620	700 to 770	840 to 930
M 24.3*3	630 to 790	890 to 990	1070 to 1180
M 27*3	930 to 1150	1300 to 1400	1560 to 1730
M 30*3.5	1260 to 1570	1770 to 1960	2200 to 2350

2.3.2 - Tightening torque for fine thread screws

<i>Nominal diameter</i>	<i>Tightening torque in N.M</i>		
	8.8	10.9	12.9
M 8*1	24 to 29	33 to 37	40 to 44
M 10*1.25	46 to 57	64 to 71	77 to 85
M 12*1.25	83 to 100	120 to 130	140 to 150
M 14*1.5	130 to 160	180 to 200	220 to 240
M 16*1.5	200 to 250	280 to 310	340 to 370
M 18*1.5	290 to 360	410 to 450	490 to 540
M 20*1.5	410 to 510	570 to 630	690 to 760
M 22*1.5	550 to 680	780 to 870	920 to 1000
M 24*1.5	690 to 860	970 to 1070	1160 to 1290
M 27*2	1000 to 1300	1400 to 1560	1690 to 1880
M 30*2	1400 to 1700	1960 to 2180	2350 to 2610

2.3.3 - Recommended torques

<i>Component</i>	<i>Tightening torque in N.M</i>
Brakes	90 N.m
Hydraulic motors	90 N.m
Wheels	250 N.m

2.4 - PRESSURE TABLE (IN BARS)

Machine	Useful load	Useful load + 10%	General pressure	Steering pressure
H8SN	Outdoor use : 120 kg Indoor use : 350 kg	Outdoor use : 132 kg Indoor use : 385 kg	200	150
H8SW	Outdoor use : 120 kg Indoor use : 450 kg	Outdoor use : 132 kg Indoor use : 495 kg	200	150
H10SN	Outdoor use : forbidden Indoor use : 230 kg	Outdoor use : forbidden Indoor use : 253 kg	200	150
H10S	Outdoor use : 120 kg Indoor use : 450 kg	Outdoor use : 132 kg Indoor use : 495 kg	200	150
H12SN	Outdoor use : 120 kg Indoor use : 300 kg	Outdoor use : 132 kg Indoor use : 330 kg	150	155

Margin: +/-10%. The lifting pressure is adjusted according to the actual load.

2.5 - ADJUSTEMENT TIMES TABLE

Movement	Movement duration				
	H8SN	HSW	H10N	H10S	H12SN
Travel - Slow speed	23 s +/-3s for 10m				
Travel - High speed	14s +/- 2s for 10m				
Travel - Micro speed	42 s +/- 5s for 10m				
Steering - right and left	5 to 6 s				
Raising	37s +/-3s	44s +/-3s	46s +/- 3s	45s +/- 3s	75s +/-3s
Lowering	41s +/- 5s	56s +/- 5s	49s +/- 5s	49s +/- 5s	52s +/- 5s

3 - WIRING DIAGRAMS

3.1 - WIRING DIAGRAM E 591A (PRESSURE SWITCH VERSION)

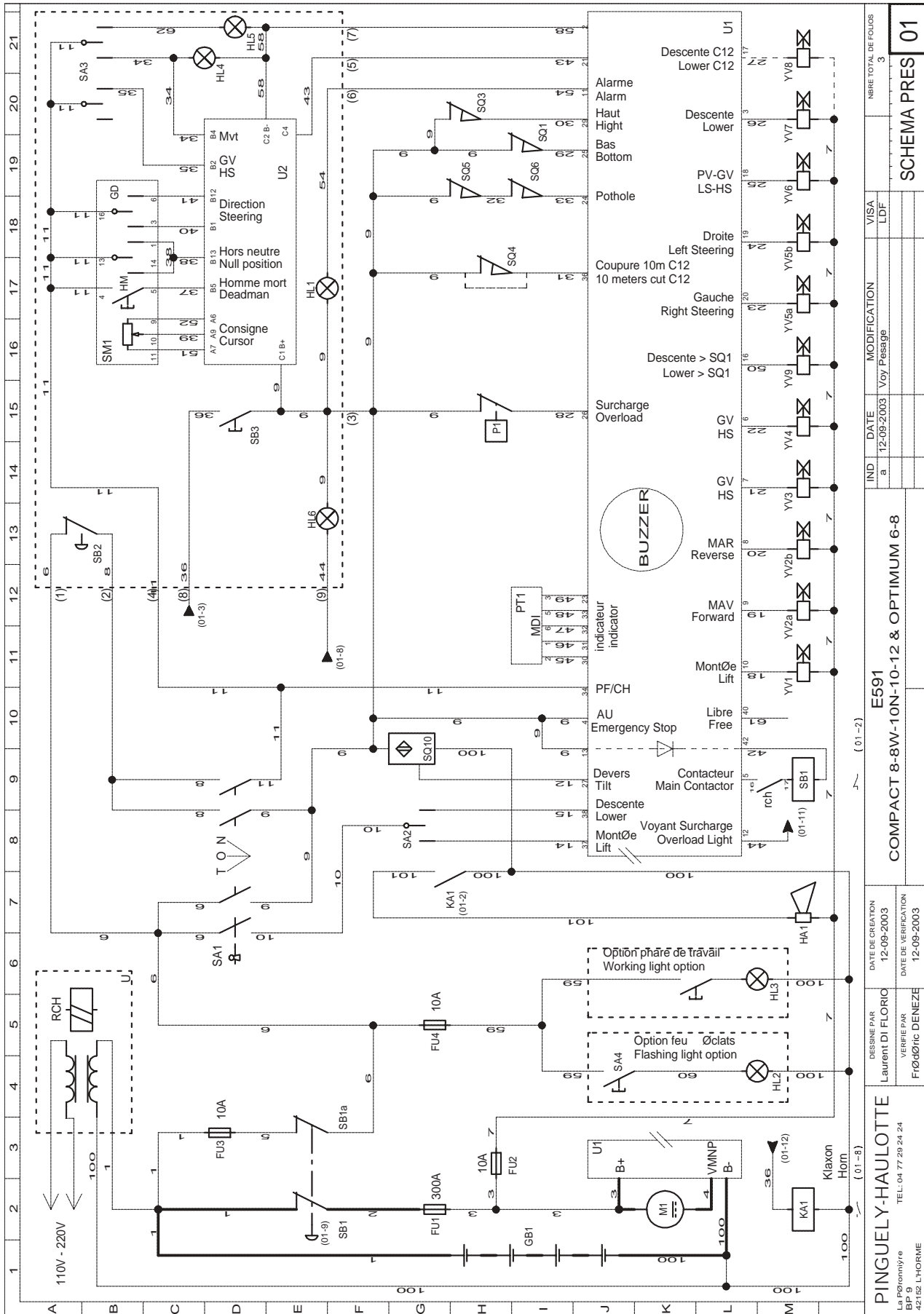

3.1.1 - Electric components : pressure switch version

Component	Description
FU1	Power fuse
FU2	Chopper output protective fuse
FU3	Controls protective fuset
FU4	Working light protective fuse
GB1	Battery
HA1	Buzzer
HL1	Situation light indicator
HL2	Flashing light
HL3	Working light
HL4	Lifting light indicator
HL5	Machine travel light indicator
HL6	Weighing light indicator
M1	Motorpump unit
PT1	M.D.I display
RCH	Battery charger relay
SA1	Control post selection
SA2	Movement selection
SA3	Platform travel / lifting selection
SA4	Working light switch
SB1	Battery cut-off / Emergency stop (chassis)
SB2	Emergency stop (platform)
SB3	Buzzer control
SM1	Manipulator
SP1	Pressure switch
SQ1	Low position contactor
SQ10	Tilt sensor
SQ3	Top position contactor
SQ4	Travel interruption switch
SQ5/SQ6	Pothole system out
U	Battery charger
U1	Electronic chopper
U2	Serial card
YV	Electrovalve

3.2 - WIRING DIAGRAM E591A : WEIGHING CARD VERSION

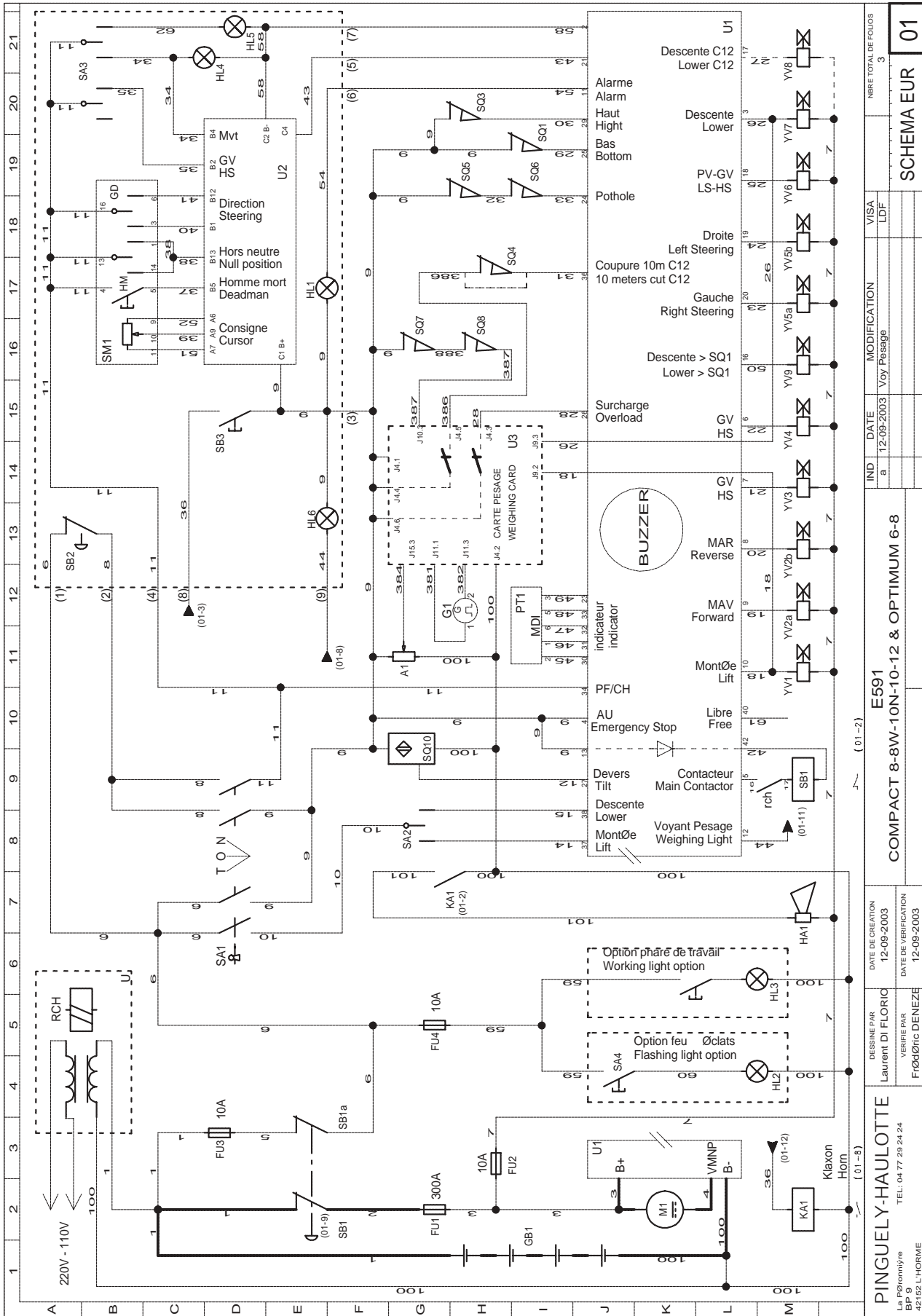

IND		DATE	MODIFICATION	VISA	NBR DE FOLIOS	01
a		12-09-2003	Voy Passage	LDJ		
E591				SCHEMA EUR		
COMPACT 8-8W-10N-10-12 & OPTIMUM 6-8						
DATE DE CREATION		DATE DE VERIFICATION				
12-09-2003		12-09-2003				
DESSINE PAR		VERIFIE PAR				
Laurent DI FLORIO		FR060hc DENEZE				
PINGUELY-HAULOTTE						
La Pinguely/Haulotte						
BP 9						
42152 L'HORNE						
TEL: 04 77 29 24 24						

3.2.1 - Electric components : weighing card version

Component	Description
A1	Weighing angle sensor
FU1	Power fuse 300A
FU2	Chopper output protective fuse
FU3	Controls protective fuse
FU4	Working light protective fuse
G1	Pressure sensor
GB1	Battery
HA1	Buzzer
HL1	Situation light indicator
HL2	Flashing light
HL3	Working light
HL4	Lifting light indicator
HL5	Machine travel light indicator
HL6	Weighing light indicator
M1	Motorpump unit
PT1	M.D.I display
RCH	Battery charger relay
SA1	Control post selection
SA2	Movement selection
SA3	Platform travel / lifting selection
SA4	Working light switch
SB1	Battery cut-off / Emergency stop (chassis)
SB2	Emergency stop (platform)
SB3	Buzzer control
SM1	Manipulator
SQ1	Low position contactor
SQ10	Tilt sensor
SQ3	Top position contactor
SQ4	Travel interruption switch
SQ5/SQ6	Pothole system out
U	Battery charger
U1	Electronic chopper
U2	Serial card
U3	Weighing card
YV	Electrovalve

4 - ELECTRIC COMPONENTS' DESCRIPTION

4.1 - CHASSIS CONTROL POST



U1

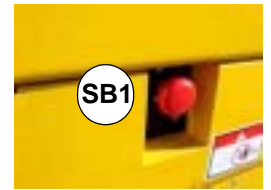

SB1

• RCH	• Battery charger relay
• SA1	• Key contactor : selection of the command either on the top console with the possibility to take off the key, or on the turntable console with no need to maintain the command.
• SA2	• Command switch driving the platform up or down. 14 Up, 15 Down
• SB1	• Main switch including battery-cut-off function
• U1	• Chopper
• PT1	• Multifunction indicator (hour recorder, unloading indicator and numeric indicator of codes statements)

4.1.1 - Switches (E591a - Pressure switch version)



SQ4 SQ1



SQ3



SQ5



SQ6



SQ10 TILT SENSOR TEST MODE

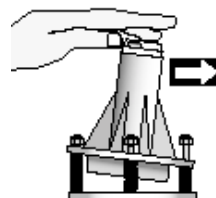

=0



SP1

• SQ1	• Low position switch : wire 28 ; 1 = low position of the platform ; 0 = high position of the platform.
• SQ3	• Low position switch; wire 29, gets on position 0 at the end of lifting and cuts the lifting command.
• SQ4	• Position switch to stop traveling at a platform height of 8 meters from the floor: wire 31
• SQ5 & SQ6	• Position switch to control the extension of potholes. The wire 31 of this circuit must be closed before SQ1 gets on 0 ; otherwise it prevents lifting and traveling. Lowering is the only solution left.
• SQ10	• Slope : wire 12 ; 1 at rest ; 0 = tilt
• SP1	• Pressure switch wires 28

4.1.2 - Fuses and motors

• FU2 10A	• Command fuse : protection of solenoid valves and horn.
• FU3 10A	• Command fuse to feed the command circuit. It protects the whole command circuit.
• FU4 10A	• Fuse protecting the feeding of the optional circuit of working head lights or flashing lights.
• FU1 250A	• Power protection fuse.
• M1	• Pump motor 24V 3000W

4.2 - PLATFORM CONTROL POST EQUIPMENT

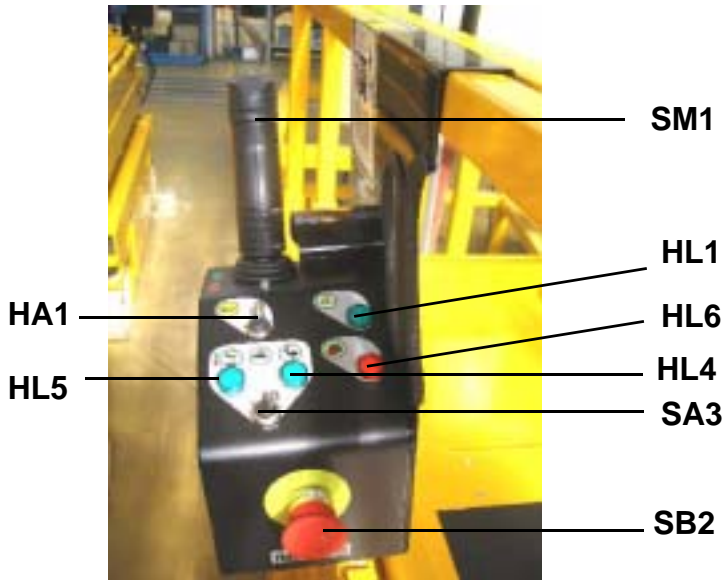

• U2	• The serial card allows compiling the different elements of the console in order to get a digital transmission signal.
• SM1	• Joystick
• SA3	• Switch selecting either lifting or slow & high travel speed.
• SB2	• Upside console emergency push button
• HA1	• Buzzer
• HL1	• Light visualising alarm codes (Flashing codes)
• HL4	• Light visualising travel motion position : slow or high travel speed of SA3
• HL5	• Light visualising lifting position of SA3
• HL6	• Weighing light indicator

4.3 - SOLENOID VALVES

• YV1	• Solenoid valve selecting travel or up & down operations. At rest it controls travel, working it drives lifting wire 18.
• YV2A	• Solenoid valve that controls the forward gear wire 19
• YV2B	• Solenoid valve that controls backward gear wire 20
• YV3	• Solenoid valve that controls high or low travel speed. At rest : low speed, working : high speed wire 21
• YV4	• Solenoid valve that controls high or low travel speed ; at rest : low speed, working : high speed ; wire 22
• YV5A	• Solenoid valve that controls steering right
• YV5B	• Solenoid valve that controls left steering
• YV6	• Solenoid valve that controls the potholes' spreading out movement only when SQ1 is on 1.
• YV7	• Solenoid valve that pilots the low cylinder lowering; wire 26.
• YV8	• Solenoid valve that pilots the up cylinder lowering - for Compact 12 wire 27
• YV9	• Solenoid valve : principal descent : ON when SQ1 is = 0 wire 50.

4.4 - END OF TRAVEL SWITCHES CHART

SWITCH	Movement to perform	Recommended adjustment					Check
		H8SN	H8SW	H10N	H10S	H12SN	
• End of travel lifting (SQ3)	• Lifting	6.15m +/- 15 cm	6.15m +/- 15 cm	8.15m +/- 15 cm	8.15m +/- 15 cm	10 m +/- 15 cm	• Lifting movement cut-off in high position
• Pothole end of travel (SQ5 and SQ6)	• Lifting						• *Potholes extension when the platform is raised at 1.5 m • *Microspeed activation
	• Disconnect YV6 • Lifting						• *Lifting movement impossible at a height superior to 1.5m • * Travel movement impossible at a height superior to 1.5 m
• Tilt resetting end of travel (SQ1)	• Lifting above 1.5m and lowering	1.75 m +/- 15cm	1.75 m +/- 15cm	1.85 m +/- 15cm	1.85 m +/- 15cm	1.85 m +/- 15cm	• *Check that the lowering movement is properly performed ; the movement must be interrupted at 1.5 m
• End of travel 8 m switch (SQ4) – H12SN only	• Lifting above 8 m						• Travel movement impossible (micro-speed cut-off)

4.5 - SERIAL CARD

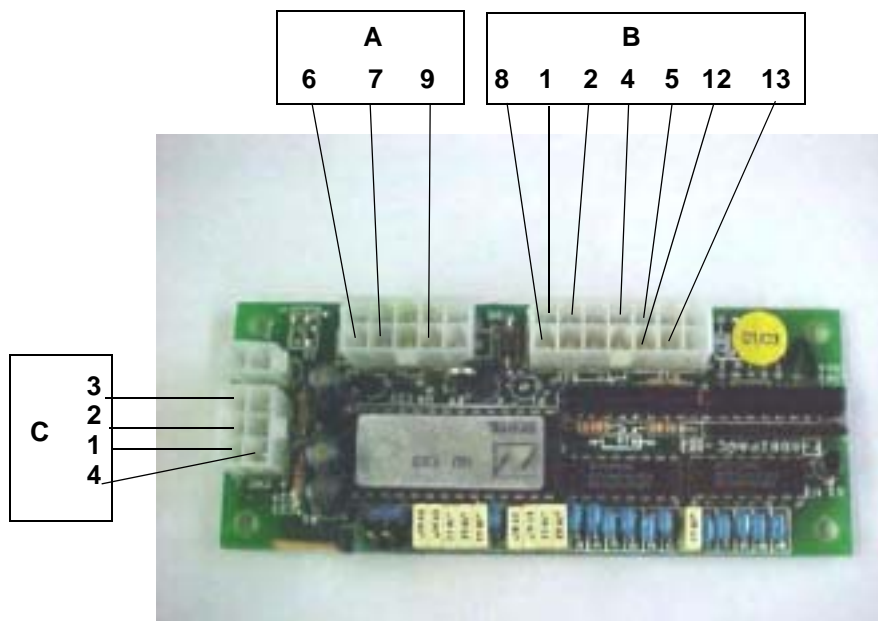

A	B	C
A7 – Wire 51 A9 – Wire 39 Accelerator A6 – Wire 52 potentiometer	B1 wire 40 : Left steering switch B12 wire 41 : Right steering switch B13 wire 38 : Except neutral B5 wire 37 : Dead man switch B2 wire 35 : Travel selection B4 wire 34 : Movement selection B8 wire 36 : Horn	C1 : battery + C2 : battery – C4 : battery signal

4.5.1 - Serial card initialization

- Emergency stop not pressed.
- Put the key on OFF (stop).
- Shunt the serial card (J1) with the help of a crimp.
- Put the key on ON (start), and operate as follows, slowly:
 - 1. Advance high speed
Return to neutral position
Release the joystick
 - 2. Backward movement high speed
Return to neutral position
Release the joystick
 - 3. Climbing
Return to neutral position
Release the joystick
 - 4. Going down
Return to neutral position
Release the joystick

When these operations have been done, release the shunt.

- Wait 5 seconds.
- Put the key in position OFF.
- Test the platform.

4.6 - MDI



The state of charge of the batteries is displayed through a series of 5 LED'S.

- 4 yellow LEDs (4 LEDs lit = batteries charged).
- 1 red LED (signals that the battery unit is discharged).

Hour meter

A liquid crystal alphanumerical display unit situated at the centre of the charge indicator dial informs the user about the number of hours performed.

Alarms

The same display unit used for the hour meter also plays the part of a state of alarm indicator providing a code corresponding to the type of alarm reported. The red LED flashes in order to attract the user's attention.

Software version

On switching off the key, the eeprom version is displayed on the dial for a few seconds (EPXXX where XXX represents the version). The English key symbol also appears during this phase.

4.7 - USING THE ON-BOARD CHARGER



Caution!

Set the chassis emergency stop on the 'OFF' position before recharging.



Caution!

In cold weather, the charging time increases.

Photo 1



4.7.1 - Characteristics

The traction batteries must be charged with the charger provided for this purpose. DO NOT OVERCHARGE THEM.

- Charger : 24 V - 30 A.
- Power supply : single-phase 220 V - 50 Hz.
- Voltage supplied : 24 V.
- Charge time : about 11 hours for batteries 70% to 80% discharged.

4.7.2 - Starting charging

Starting is automatic on connection to the mains. The charger is equipped with 1 indicator light :

- The indicator signals charging in progress.

State	Description
RED on	Machine charging
YELLOW on	80% charged
GREEN on	Machine charging complete

4.7.3 - Holding charge

If the charger remains connected to the mains for a period greater than 48 hours, it re-starts a charging cycle after the end of the preceding charge so as to compensate for self-discharging.

4.7.4 - Interrupting charging

The charger is stopped by disconnecting the mains plug. If it is necessary to operate the machine during a charging cycle, it is necessary to disconnect the charger. This might reduce the battery's life time. After the operation, re-connect the charger again.

4.7.5 - Precautions in use

- Avoid recharging the batteries if the temperature of the electrolyte is over 40C.
- Let it cool down.
- Keep the top of the batteries dry and clean. An incorrect connection or corrosion can cause considerable loss of power.
- If new batteries are fitted, recharge after 3 or 4 hours of use and do so 3 to 5 times.
- The charger has been adjusted in the factory with the cable with which it is equipped. If this cable is replaced, it is important to contact the PINGUELY-HAULOTTE factory so that they can give you their agreement.

4.8 - CHOPPER

4.8.1 - Terminal-wire connections chart



Terminal	Wire		Terminal	Wire		Terminal	Wire	
1		Not in use	15		Not in use	29	39	Top position end of travel input (SQ3)
2	58	Input -	16	50	Lifting solenoid valve output YV9	30	45	MDI signal
3	26	Lowering control YV7 solenoid valve	17	27	Not in use	31	46	MDI signal
4	9	Input +	18	25	Pothole command solenoid valve YV6	32	47	MDI signal
5	16	Output SB1 control	19	24	Left steering solenoid valve control output YV5b	33	48	MDI signal
6	22	Output YV4 HS control	20	23	Right steering solenoid valve control output YV5a	34	11	Top control panel validation
7	21	Output YV3 HS control	21	43	Series signal input	35		Not in use
8	20	Output YV 2 b Reverse gear control	22	12	Not in use	36	31	+ Batterie
9	19	Output YV2a Forward gear control	23	49	MDI signal	37	14	Chassis lifting control
10	18	Output supplying YV1 : travel movement selection	24	33	Pothole end of travel input (SQ5 and SQ6)	38	15	Chassis lowering input
11	54	Input – indicator light Default indicator	25	29	Low position end of travel input (SQ1)	39		Not in use
12	44	Horn control	26	28	Overload pressure switch input (SP1)	40	61	Not in use
13	9	Input +	27	12	Tilt indicator signal	41		Not in use
14		Not in use	28		Not in use	42	42	SB1 control output

5 - HYDRAULIC DIAGRAMS

5.1 - HYDRAULIC DIAGRAM FOR COMPACT 8, 8W, 10N AND 10 MODELS (B16187A)

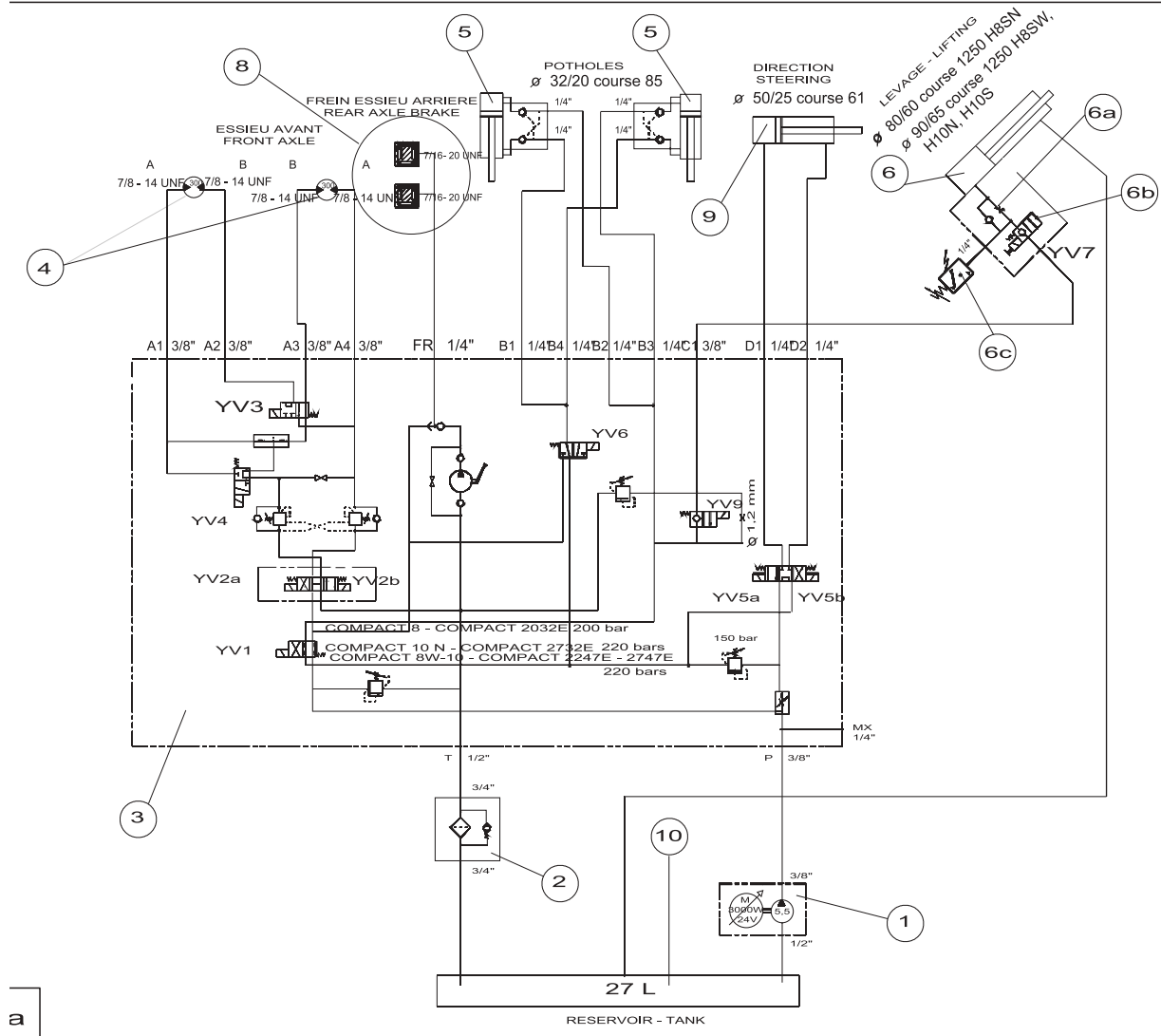

5.1.1 - List of components

Part	Marker	Qty	Comments
2420701800 – Pump motor unit 3000W 24V DC	1	1	
2427010430 – Oil filter 3/4 BSPP	2	1	
2420212090 - MK4 distribution block	3	1	
2431202050 – Hydraulic motor 300CC - SP.5122	4	2	
118C148380 – Pothole cylinder	5	2	
120C149400 – Lifting cylinder SP.5044	6	1	(Compact 8W, 10N / 10)
118C149390 – Lifting cylinder	6	1	(Compact 8)

5.2 - HYDRAULIC INSTALLATION DIAGRAM FOR COMPACT 8 (A14562B)

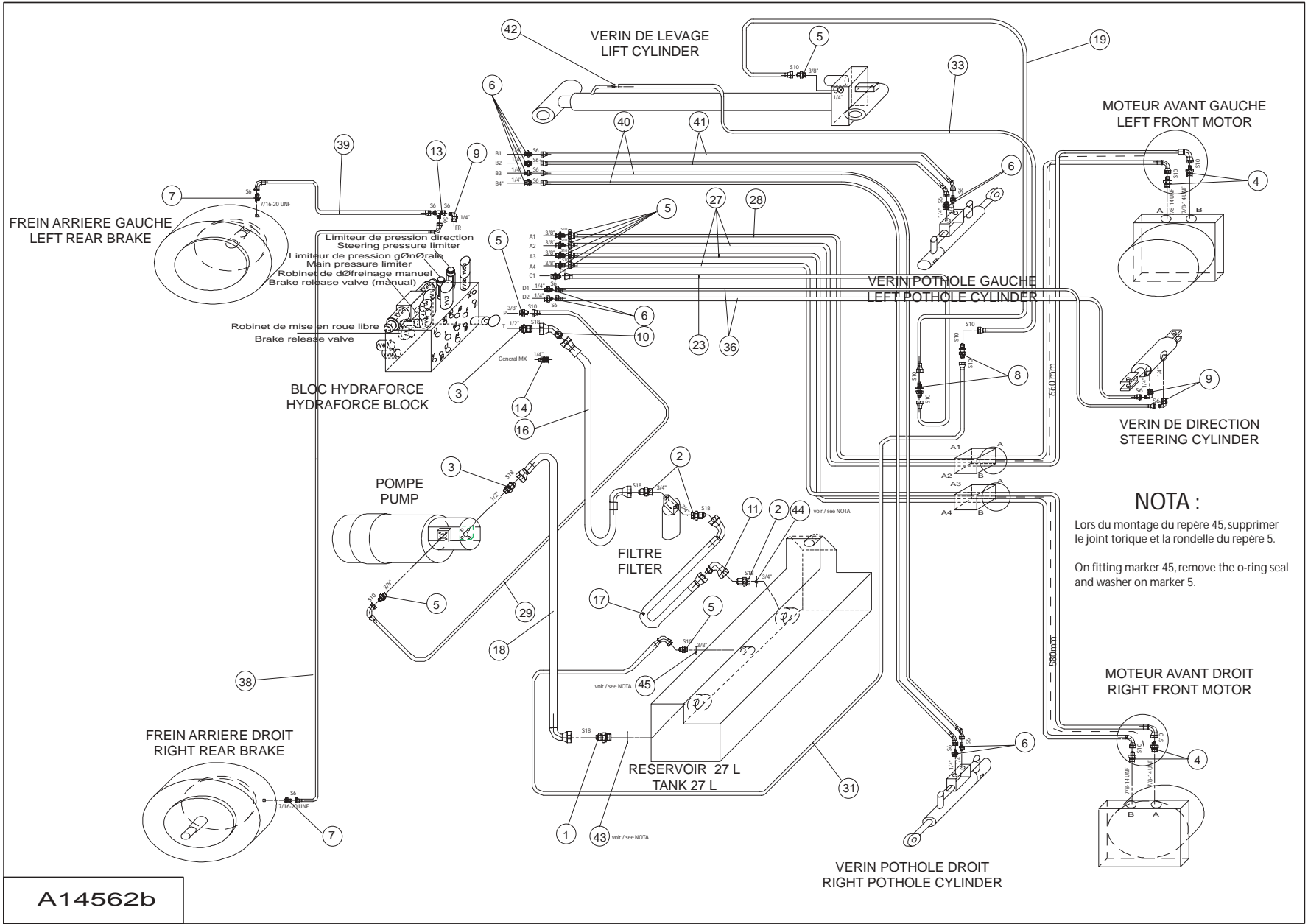

NOTA :
 Lors du montage du repère 45, supprimer le joint torique et la rondelle du repère 5.
 On fitting marker 45, remove the o-ring seal and washer on marker 5.

A14562b

5.2.1 - Components listed in diagram A14652b

Part	Marker	Qty	Comments
2369110220 – Union piece M.JIC37 (18)M 1 BSPP	1	1	
2369117210 - Union piece M.JIC 37	2	3	
2369117190 - Union piece M.JIC 37	3	2	
2369111430 - Union piece male JIC37(10)M.7/8-14 UNF	4	4	
2369117360 - Union piece M JIC37	5	9	
2369117120 - Union piece M.JIC 37	6	10	
2369111440 - Union piece male JIC37(6)M.7/16-20 UNF	7	2	
2369109100 - Union piece TC M.JIC 37 (10)	8	2	
2369132090 - Bend JIC 37 90°	9	3	
2369135180 - Bend JIC 37 90°	11	1	
2369147000 – Equal T piece JIC 37	13	1	
2441604150 – Minimes tap 1/4' G	14	1	
2369071110 - Hose S449 0,55m	15	1	
2369071690 - Hose SP 5241 lg 600	17	1	
2369071700 - Hose SP 5241 lg 540	18	1	
2369070820 - Hose SP.1756 3,100m	19	1	
2369071350 - Hose S1756 1,25m	23	1	
2369071740 - Hose SP 5250 1,800m	27	3	
2369071750 - Hose SP 5250 1,650m	28	1	
2369071760 - Hose SP 5250 0,930m	29	1	
2369071770 - Hose SP 5239 0,920m	31	1	
2369071420 - Hose S5175 3,82m	33	1	
2369069640 - Hose S1707 1,51m	36	2	
2369071790 - Hose SP. 5238 1,030m	38	1	
2369071800 - Hose SP. 5238 0,530m	39	1	
2369071810 - Hose SP. 5255 1,1710m	40	2	
2369071820 - Hose SP. 5255 1,510m	41	2	
2389002540 - Collar	42	1	
118D160580 - Washer Ø41,5/33 ep=2	43	1	
118D160570 - Washer Ø36/27 ep=2	44	1	
118D160560 - Washer Ø23,5/17 ep=2	45	1	

5.3.1 - Components listed in diagram A14653b

Part	Marker	Qty	Comments
2369110220 – Union piece M.JIC37 (18)M 1 BSPP	1	1	
2369117210 - Union piece M.JIC 37	2	3	
2369117190 – Union piece M.JIC 37	3	2	
2369111430 – Union piece male JIC37(10)M.7/8-14 UNF	4	4	
2369117360 – Union piece M JIC37	5	9	
2369117120 – Union piece M.JIC 37	6	10	
2369111440 – Union piece male JIC37(6)M.7/16-20 UNF	7	2	
2369109100 - Union piece TC M.JIC 37 (10)	8	2	
2369132090 - Bend JIC 37 90°	9	3	
2369135180 – Bend JIC 37 90°	11	1	
2369147000 – Equal T piece JIC 37	13	1	
2441604150 - Minimess tap 1/4' G	14	1	
2369071110 - Hose S449 0,55m	15	1	
2369071690 - Hose SP 5241 lg 600	17	1	
2369071700 - Hose SP 5241 lg 540	18	1	
2369070820 - Hose SP.1756 3,100m	19	1	
2369058900 - Hose SP.1756 1,3m	22	1	
2369071650 - Hose SP. 5250 2,050m	25	1	
2369071730 - Hose S5239 Lg 1950	26	3	
2369071760 - Hose SP 5250 0,930m	29	1	
2369071770 - Hose SP 5239 0,920m	31	1	
2369071420 - Hose S5175 3,82m	33	1	
2369069640 - Hose S1707 1,51m	36	2	
2369071780 - Hose S5238 Lg 1370	37	1	
2369071800 - Hose SP. 5238 0,530m	39	1	
2369071810 - Hose SP. 5255 1,1710m	40	2	
2369071820 - Hose SP. 5255 1,510m	41	2	
2389002540 - Collar	42	1	
118D160580 - Washer Ø41,5/33 ep=2	43	1	
118D160570 - Washer Ø36/27 ep=2	44	1	
118D160560 - Washer Ø23,5/17 ep=2	45	1	

5.4 - HYDRAULIC DIAGRAM FOR COMPACT 12 MODEL (B16188A)

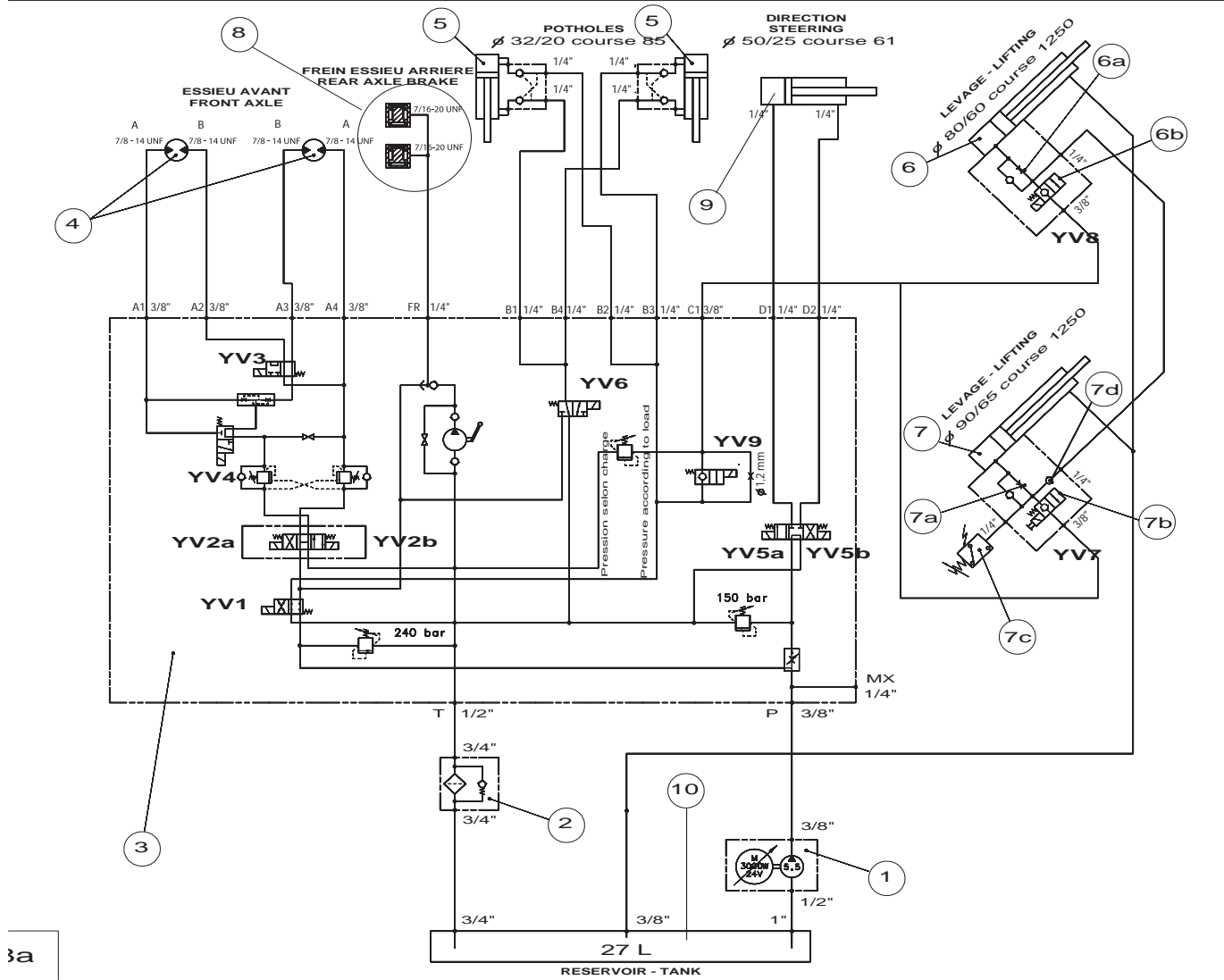

5.4.1 - List of components

Part	Marker	Qty	Comments
2420701800 – Motor pump unit 3000W 24V DC	1	1	
2427010430 – Oil filter 3/4 BSPP	2	1	
2420212090 - MK4 distribution block	3	1	
2431202050 – Hydraulic motor 300CC - SP.5122	4	2	
118C148380 - Pothole cylinder	5	2	
118C150590 – Lifting cylinder	6	1	
121C156140 – Lifting cylinder 65/90	7	1	

5.5 - HYDRAULIC INSTALLATION DIAGRAM FOR COMPACT 12 (A14564C)

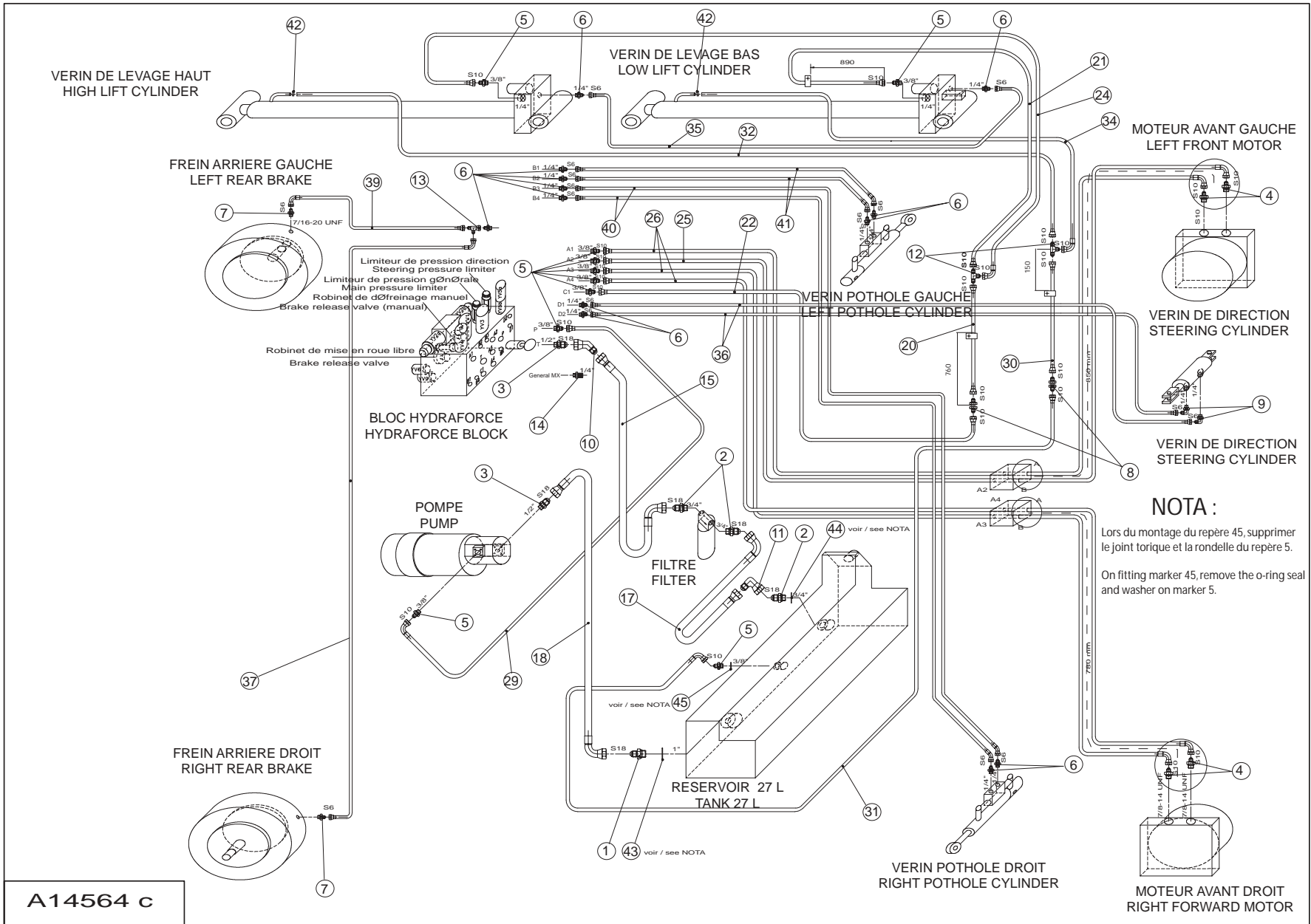

NOTA :
 Lors du montage du repère 45, supprimer le joint torique et la rondelle du repère 5.
 On fitting marker 45, remove the o-ring seal and washer on marker 5.

A14564 c

5.5.1 - Components listed in diagram A14564c

Part	Marker	Qty	Comments
2369110220 – Union piece M.JIC37 (18)M 1 BSPP	1	1	
2369117210 - Union piece M.JIC 37	2	3	
2369117190 - Union piece M.JIC 37	3	2	
2369111430 - Union piece male JIC37(10)M.7/8-14 UNF	4	4	
2369117360 - Union piece M JIC37	5	9	
2369117120 - Union piece M.JIC 37	6	12	
2369111440 - Union piece male JIC37(6)M.7/16-20 UNF	7	2	
2369109100 - Union piece TC M.JIC 37 (10)	8	2	
2369132090 – Bend JIC 37 90°	9	3	
2369135180 - Bend JIC 37 90°	11	1	
2369141100 – Equal T-piece M JIC 37	12	2	
2369147000 – Equal T-piece JIC 37	13	1	
2441604150 – Minimes tap 1/4' G	14	1	
2369071110 – Hose S449 0,55m	15	1	
2369071690 - Hose SP 5241 lg 600	17	1	
2369071700 - Hose SP 5241 lg 540	18	1	
2369006290 - Hose	20	1	
2369071390 - Hose	21	1	
2369058900 - Hose SP.1756 1,3m	22	1	
2369071650 - Hose SP. 5250 2,050m	25	1	
2369071730 - Hose S5239 Lg 1950	26	3	
2369071760 - Hose SP 5250 0,930m	29	1	
2369059440 - Hose SP.1786 1,2m	30	1	
2369071770 - Hose SP 5239 0,920m	31	1	
2369072930 - Hose SP.5175 LG.6800	32	1	
2369071830 - Hose S5256 2,42m	34	1	
2369069640 - Hose S1707 1,51m	36	2	
2369071780 - Hose S5238 Lg 1370	37	1	
2369071800 - Hose SP. 5238 0,530m	39	1	
2369071810 - Hose SP. 5255 1,1710m	40	2	
2369071820 - Hose SP. 5255 1,510m	41	2	
2389002540 - Collar	42	1	
118D160580 - Washer Ø41,5/33 ep=2	43	1	
118D160570 - Washer Ø36/27 ep=2	44	1	
118D160560 – Washer Ø23,5/17 ep=2	45	1	

6 - DESCRIPTION OF THE HYDRAULIC CIRCUIT

6.1 - HYDRAULIC BLOCK'S COMPONENTS

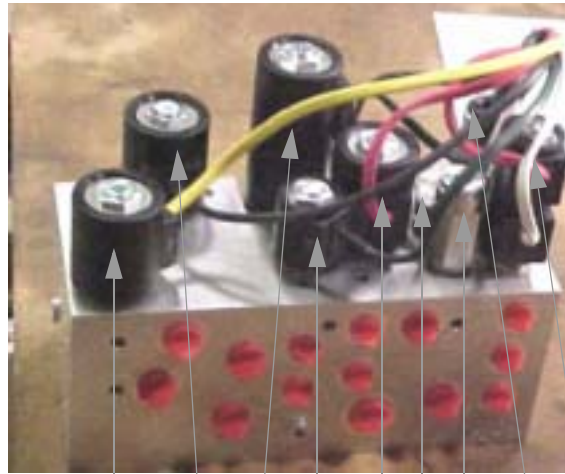

1 2 3 4 5 6 7 8 9

Marker	Part	Description
1	YV3	244 050 7620 Parallel serial coupling Low speed / High speed travel
2	YV4	244 050 7610 Parallel serial coupling Low speed / High speed travel
3	YV2	244 050 8580 Solenoid valve selecting direction of travel
4	YV6	244 050 8590 Pothole control solenoid valve
5	YV1	244 050 7590 Travel/ lifting selection solenoid valve
6	FRT	242 220 4980 Priority valve
7	RV2	242 120 3240 Main pressure regulating valve
8	RV3	242 120 3510 Lifting pressure regulating valve
9	YV	244 050 8570 Steering solenoid valve
10	RV1	242 120 3520 Steering pressure regulating valve
11	FD1	242 040 2610 Travel flow divider
12	CB2	242 220 5310 Balancing valve
13	CB1	242 220 5310 Balancing valve

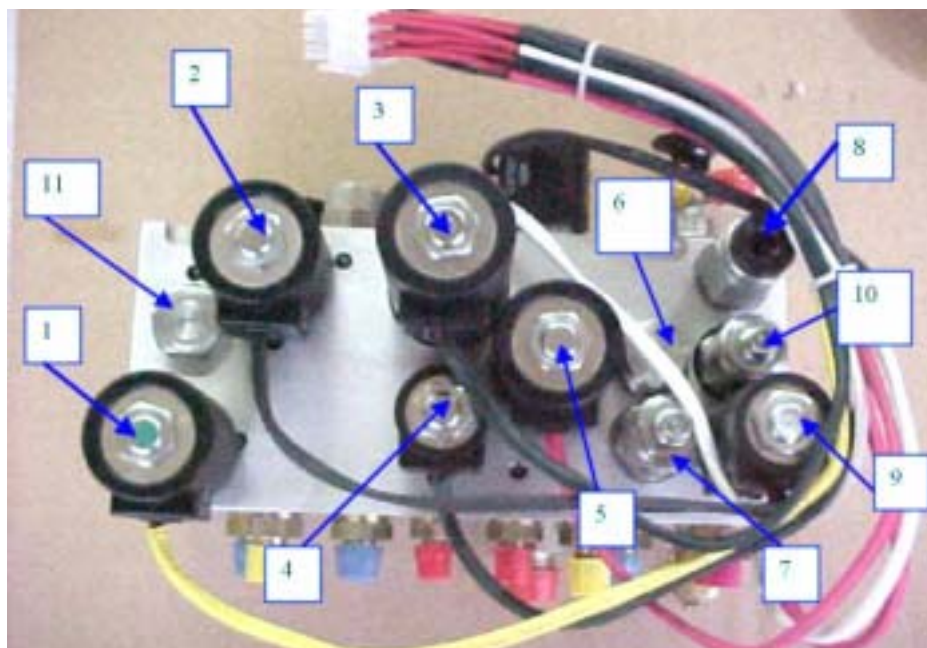

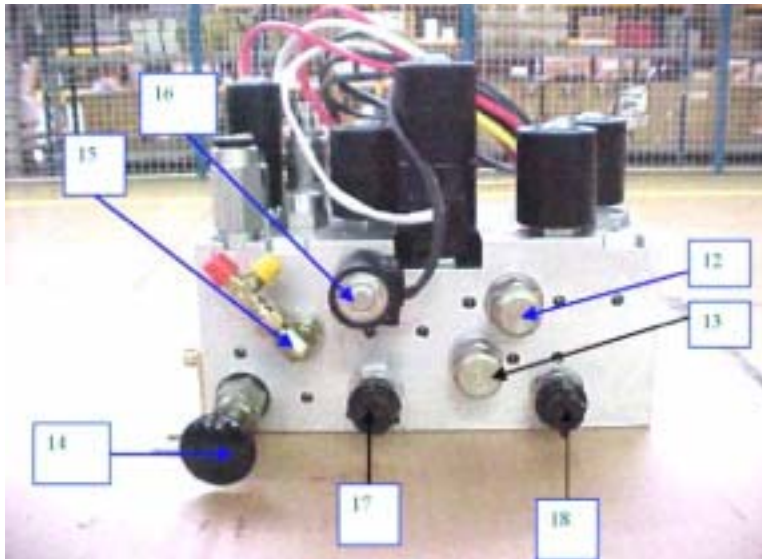

Marker	Part	Description
15	FR	Rear brakes power supply output
16	YV3	244 050 8560 Lifting solenoid valve
17	NV1	242 180 8630 Brake release discharge valve
18	NV2	242 180 8630 Balancing valves by-pass valve
14		242 160 9590 Hand pump

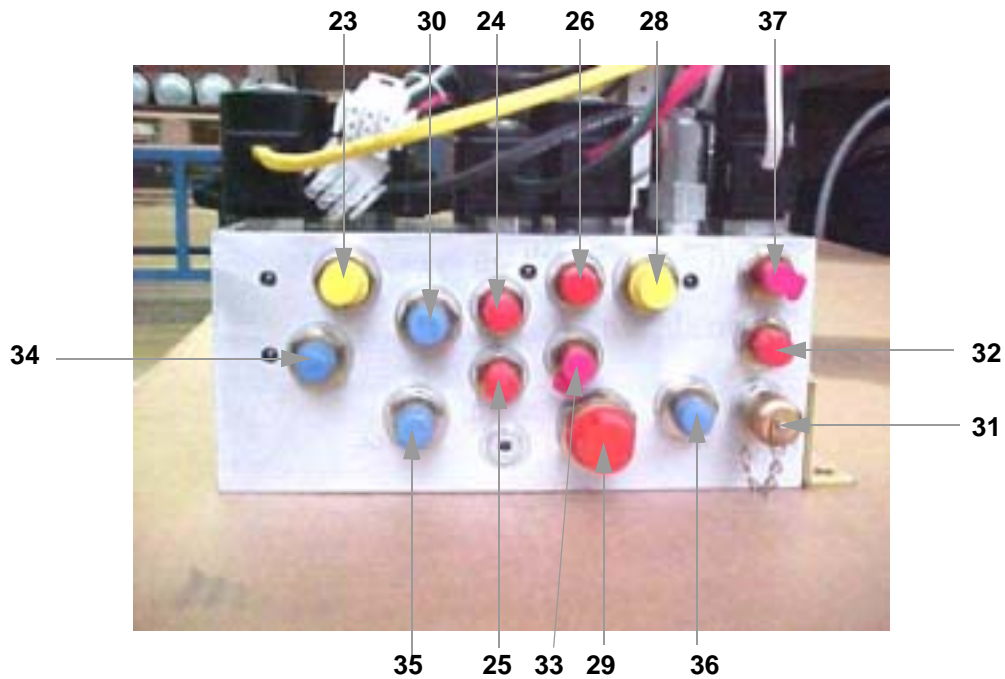

Block's output

Marker	Part - description	Marker	Part - description
23	A1 - Front left travel motors power supply output	31	MX - Minimes tap output – port gauge
24	B1 - Pothole re-entry block output	32	D1 - Steering cylinder power supply output
25	B4 - Pothole re-entry block output	33	B3 - Pothole spreading out device
26	B2 - Potholes spreading out device	34	A2 - Front left travel motors power supply output
28	C1 - YV9 lifting power supply output	35	A3 - Front right travel motors power supply output
29	T - Block output for returning to the tank through the hydraulic filter	36	P Block input taken on the block's output
30	A4 - Front right travel motors output	37	D2 Steering cylinder power supply output

6.2 - MK4 HYDRAULIC BLOCK SPECIFICATIONS

		SPECIFICATION
Date : 01/07/03	Page : 1/5	Numéro S5625
Machines: COMPACT8/10/12 OPTIMUM6/8	Auteur : A. GOSSIAUX	Vérificateur : M. JEANNARD
Modifications		

SPECIFICATIONS

Haulotte reference: 242 021 2090

Maximum pressure: 240 bar

Flow: 18 l/minute

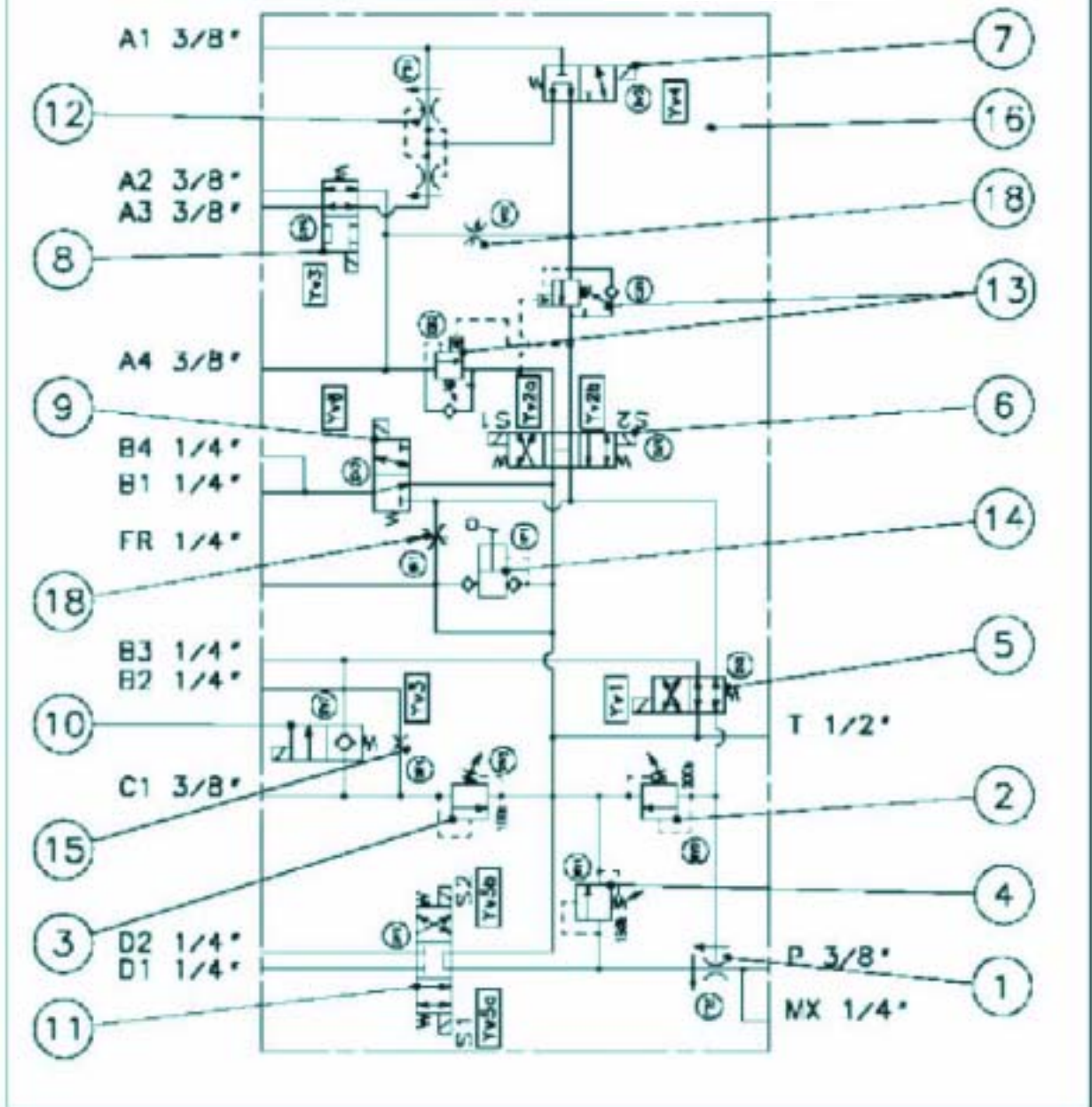

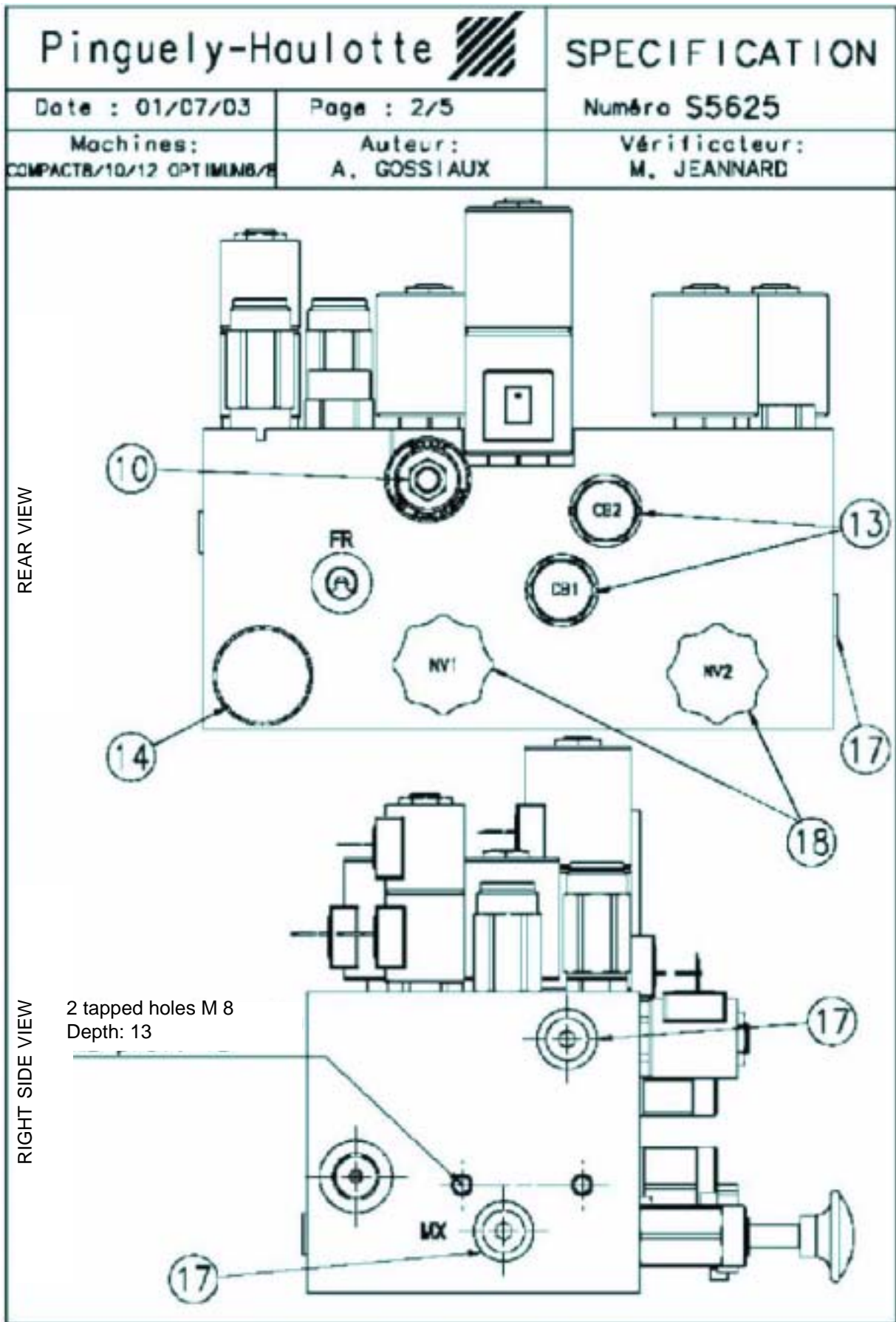

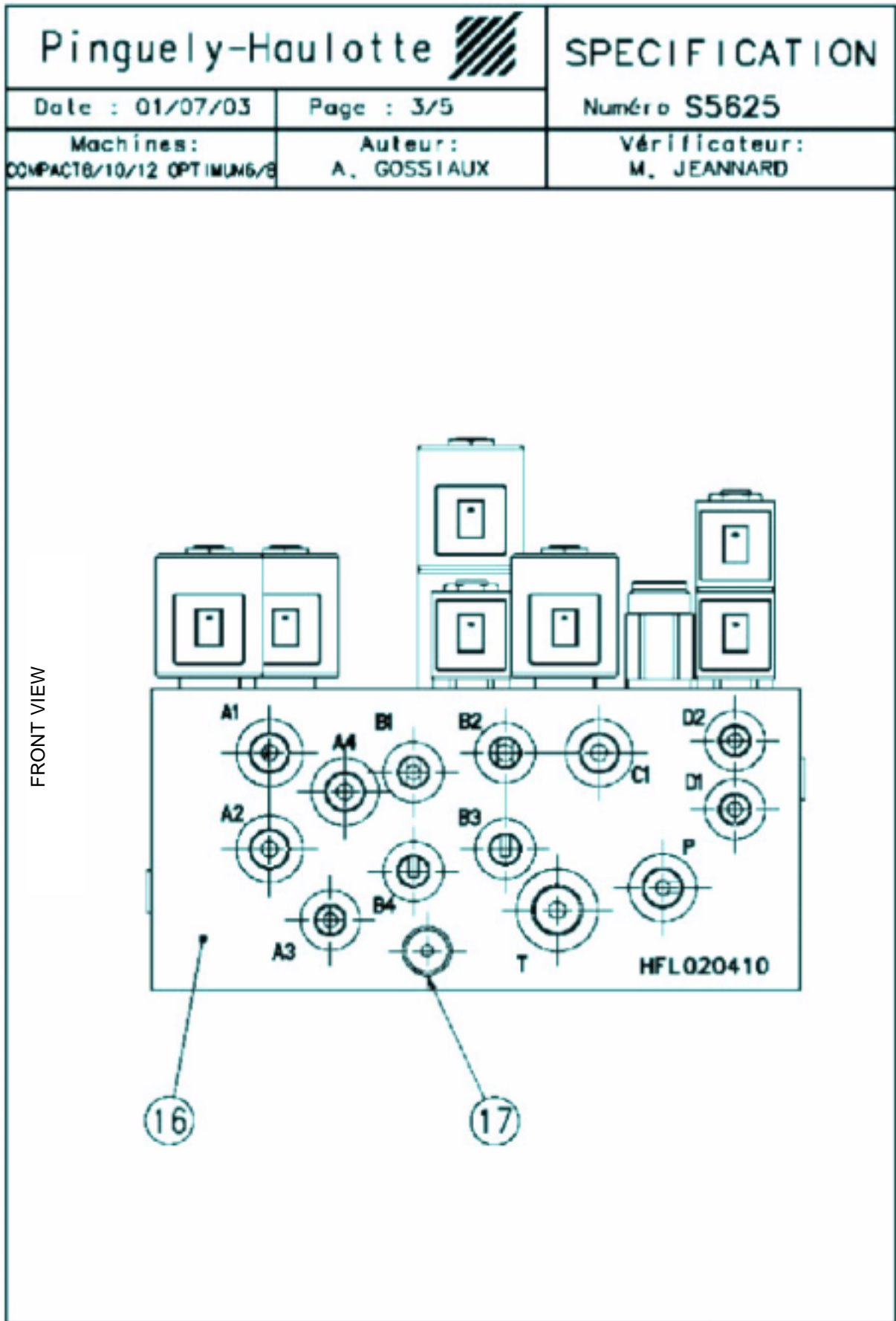

6.2.1 - List of components (Page 5 of 5 in S5625)

Marker	Description	Haulotte reference
1	Priority valve	242 220 4980
2	Main pressure regulating valve	242 120 3240
3	Lifting pressure regulating valve	242 120 3510
4	Steering pressure regulating valve	242 120 3520
5	Screw-in cartridge electrovalve	244 050 7590
6	Screw-in cartridge electrovalve	244 050 8580
7	Screw-in cartridge electrovalve	244 050 7610
8	Screw-in cartridge electrovalve	244 050 7620
9	Screw-in cartridge electrovalve	244 050 8590
10	Screw-in cartridge electrovalve	244 050 8560
11	Screw-in cartridge electrovalve	244 050 8570
12	Flow divider	242 040 2610
13	Balancing valve	242 190 5310
14	Hand pump	242 160 9590
15	Spray nozzle (Orifice plug)	242 070 3510
16	Block	242 021 2100
17	Plug	242 020 9890
18	Safety valve	242 180 8630

6.3 - HYDRAULIC FUNCTIONING**6.3.1 - Operating equation**

- Steering
 - Right =YV5 A
 - Left =YV5 B
- Lifting
 - YV1 + YV6 (When < SQ1)
- Descent
 - > SQ1 =YV9 + YV 7 + YV 8(if C12) +YV6
 - < SQ1 =YV 7 + YV 8(if C12)
- Travel motion
 - Slow speed frontward gear: YV2A
 - Slow speed backward gear: YV2B
 - High speed frontward gear: YV2A + YV3 + YV 4
 - High speed backward gear: YV2B + YV3 + YV 4

6.3.2 - Solenoid valves' functioning

Common hydraulic diagram for compact and optimum machines

Front axle Brake rear axle Steering Lifting

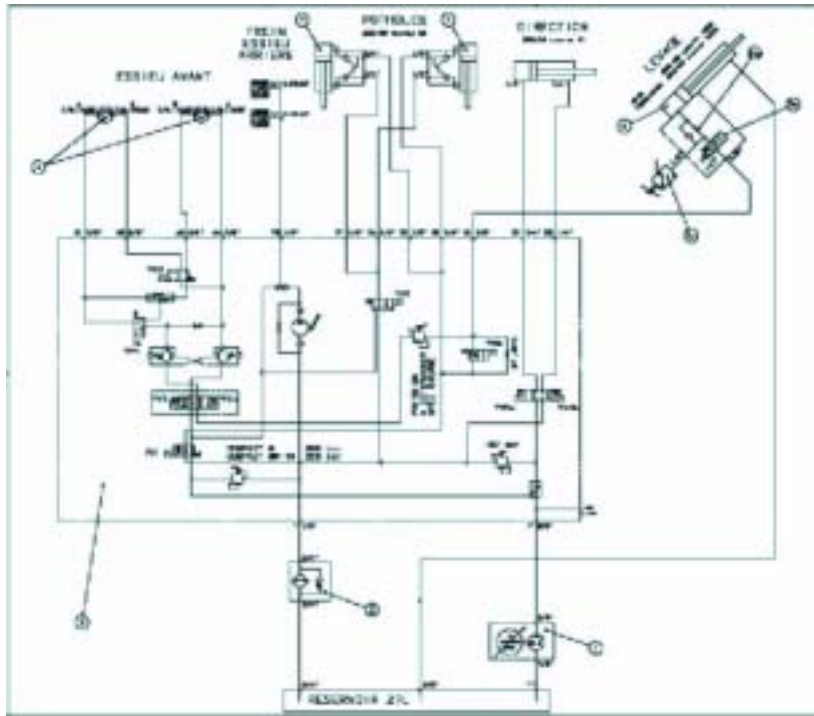

6.3.3 - Direction of travel and anti-rolling selection

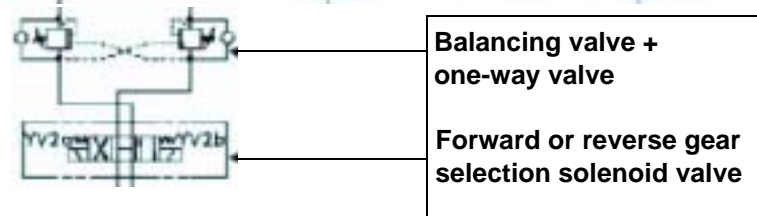
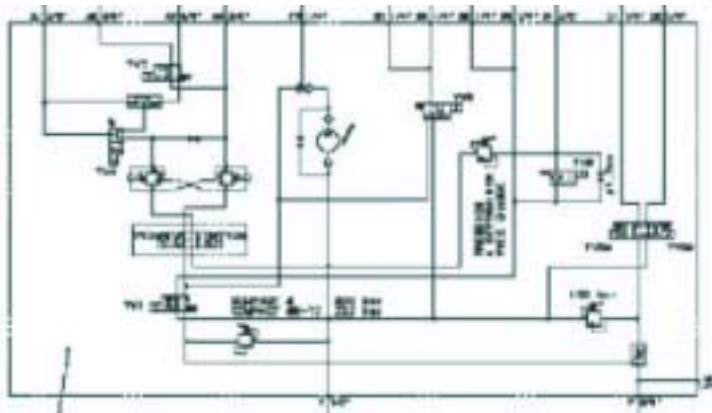

Balancing valve + one-way valve

Forward or reverse gear selection solenoid valve

6.3.4 - Speed selection

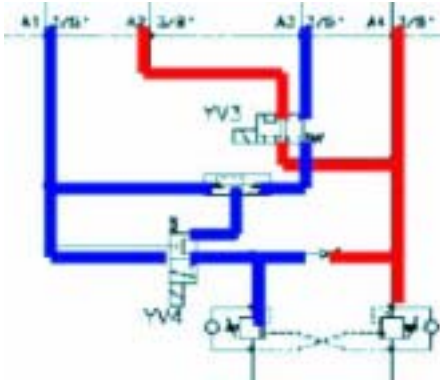

Forward gear slow speed
(travel motor in parallel)

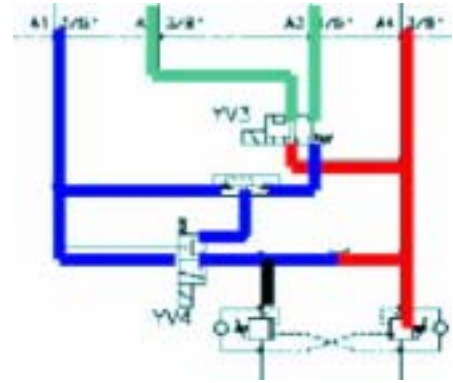

Forward gear high speed
(travel motor in series)

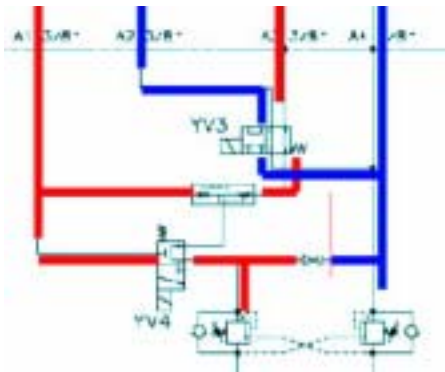

Reverse gear slow speed
(travel motor in parallel)

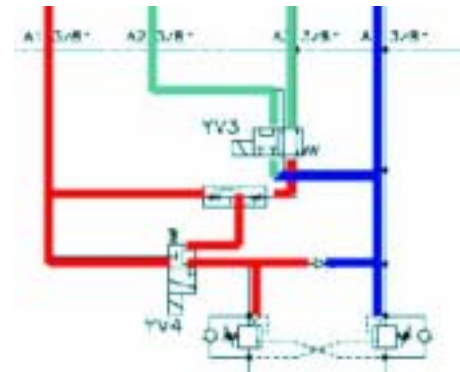

Reverse gear high speed
(travel motor in series)

6.3.4.1 - Fonctioning of balancing valves

The solenoid valve in use is that placed on the return position ; its main role consists in keeping an equilibrium in the travel circuit pressures and ensuring a constant speed preventing the machine from rolling when on ramps. In the following diagram we shall consider that the machine is in forward gear.

YV1 - Travel / movement selection solenoid valve

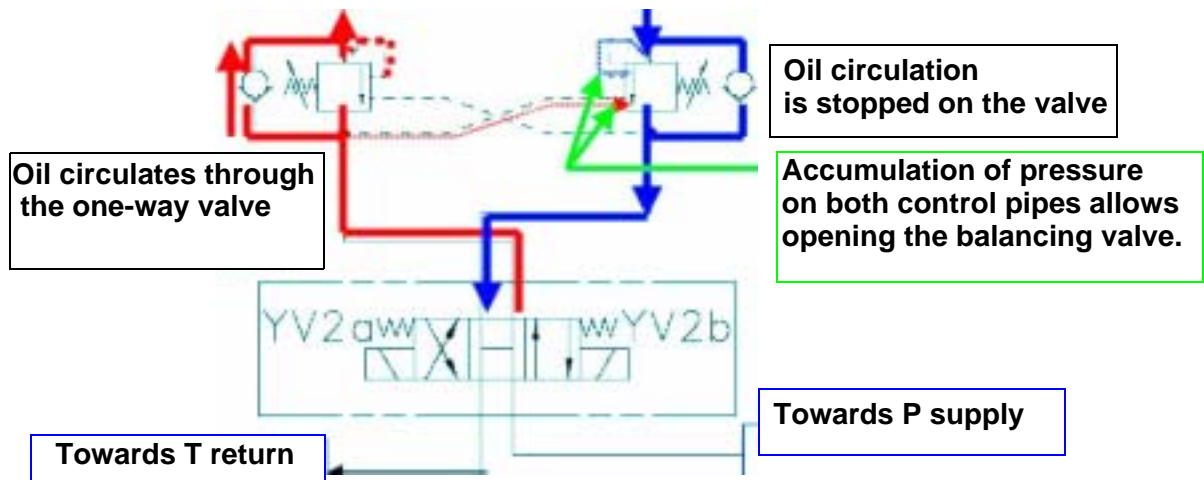

6.3.4.2 -Rear wheels' brake release power supply

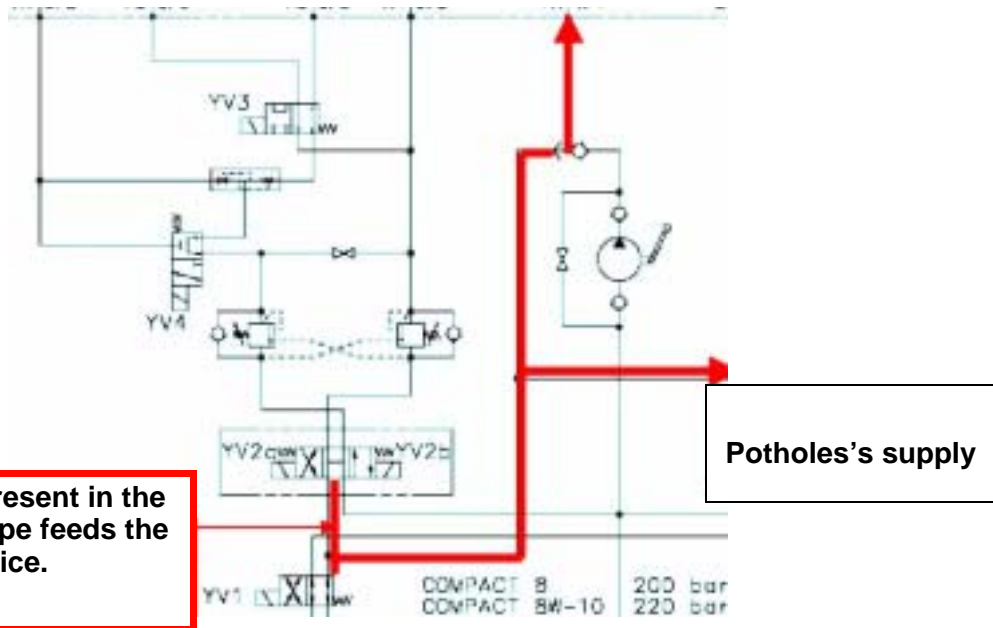

Pressure being present in the travel pressure pipe feeds the brake release device.

Potholes's supply

6.3.4.3 -Potholes' functioning

When using the lifting command, hydraulic oil circulation is supervised through the following solenoid valves :

- YV1 (in operation position)

Travel/lifting selection. In the lifting position the oil is directed towards the lowering solenoid valve as indicated in the diagram above, by passed during lifting and on the two pothole cylinders chambers. The oil present in the small chambers is sent back to the tank through the YV6 solenoid valve. This solenoid valve will be powered as long as the machine is under the SQ1 switch.

- YV6: Pothole control solenoid valve.

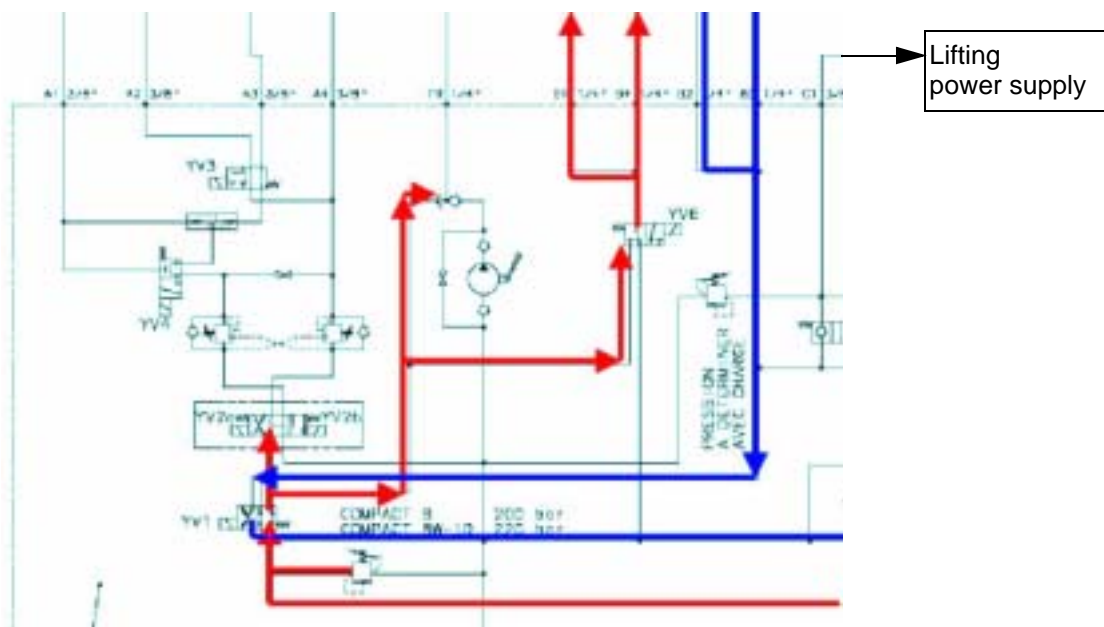

Lifting power supply

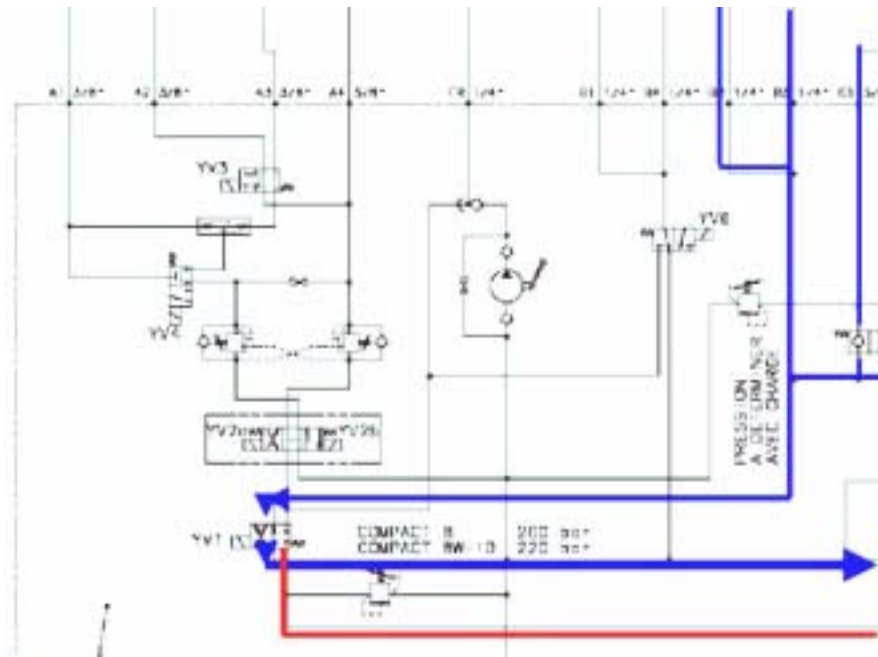

Lowering

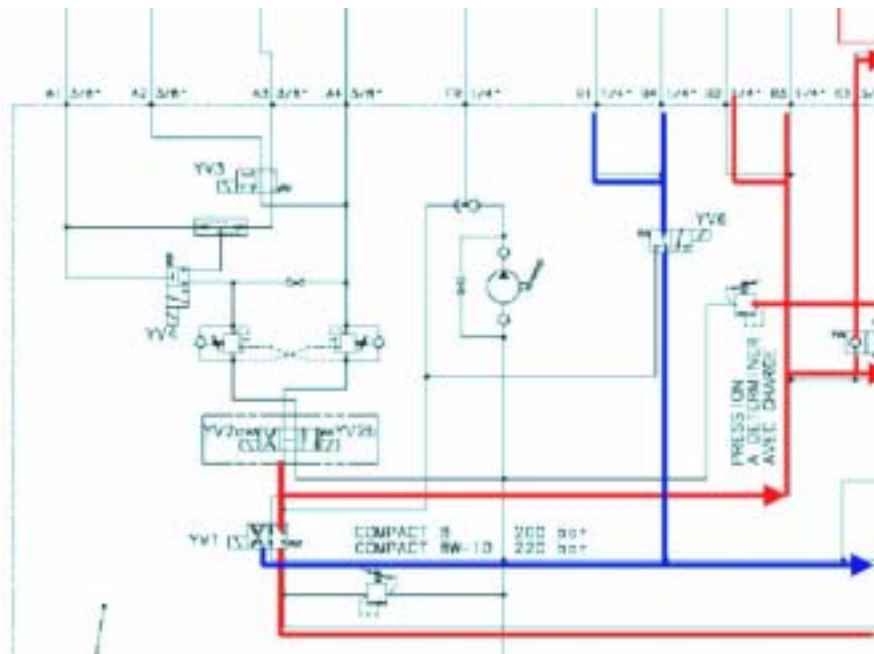

Potholes' re-entry on starting a travel movement under SQ1

6.3.5 - Steering functioning

In the hydraulic block input, the oil first passes through a priority valve. The latter powers steering through a priority flow.

It is necessary that YV1 be at rest (Travel selection)

The choice of YV5A or B depends on the direction requested for steering.

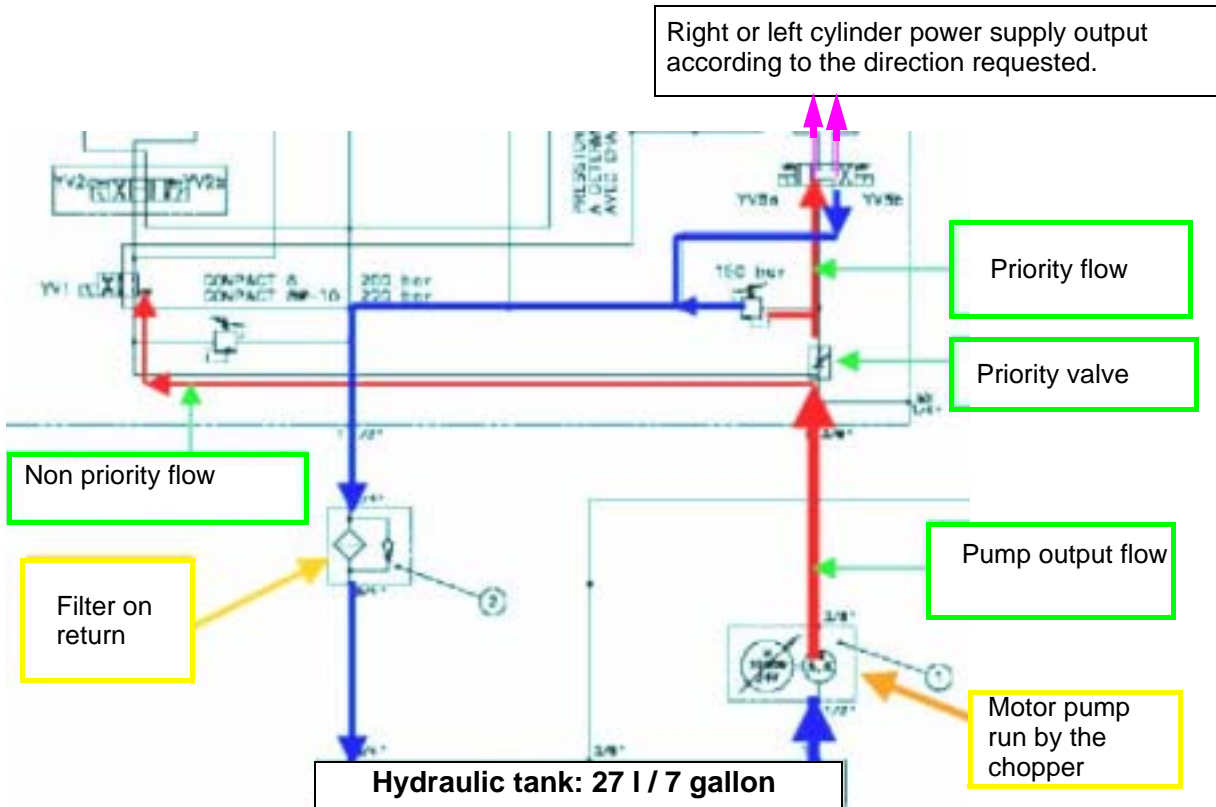

Right or left cylinder power supply output according to the direction requested.

Priority flow

Priority valve

Non priority flow

Filter on return

Pump output flow

Motor pump run by the chopper

Hydraulic tank: 27 l / 7 gallon

7 - MAINTENANCE

7.1 - GENERAL RECOMMENDATIONS



Caution!

Do not use the machine as a welding ground.

Do not weld without disconnecting the (+) and (-) battery terminals.

Do not start other vehicles with the batteries connected.

Servicing operations described in this manual are given for normal conditions of use.

In difficult conditions: extreme temperatures, high hygrometry, polluted atmosphere, high altitude, etc., certain operations must be carried out more frequently and specific precautions must be taken: consult the PINGUELY HAULOTTE After-Sales Service for information.

Only authorised and competent personnel may operate on the machine and must comply with the safety instructions related to Personnel and Environment protection.

Regularly check that the safety systems work properly:

1°) Tilt: buzzer + stop (travel and lifting disabled).

2°) Platform overload - load.

7.2 - MAINTENANCE DEVICE

The maintenance stand enables the operator to work under the machine in total safety.

Instructions: for the COMPACT 8, 10N (see:Photo 2, page 51)

Installing the maintenance stand:

Photo 2



- Position the elevation platform on a firm, horizontal floor.
- Ensure that the two emergency stop buttons are "ON".
- Turn the chassis ignition key to the "Chassis" position.
- Move the chassis lifting switch up to raise the platform.
- Turn the maintenance stand forwards and allow to hang vertically on the lower axle pivot tube.
- Push the lifting switch down to gradually lower the platform until the maintenance stand comes up against the lower pivot tube.

Photo 3



Removing the maintenance stand:

- Push the chassis lifting switch up and gradually lift the platform until the maintenance stand is free of the lower pivot tube.
- Turn the maintenance stand towards the back to bring it into its storage position on the cylinder fixture.
- Push the chassis lifting switch down and lower the platform completely.

Operating instructions: for the COMPACT 8W, 10, 12

(see: Photo 3, page 51)

These operations are to be carried out on both sides of the platform.

Putting the maintenance stand into place:

- Position the platform on a firm, horizontal floor.
- Ensure that the two emergency stop buttons are "ON".
- Turn the chassis ignition key to the "Chassis" position.
- Push the chassis lifting switch up to raise the platform.
- Unscrew and turn the maintenance stand and allow to hang vertically.
- Push the lifting switch down to lower the platform gradually until the maintenance stand comes up against the two fixing points (top and bottom).

Removing the maintenance stand:

- Push the chassis lifting switch up and gradually raise the platform until the maintenance stand is free.
- Turn the maintenance stand until it comes into its storage position and screw back into place.
- Push the chassis lifting switch down and lower the platform completely.

7.3 - ELECTRICITY SUPPLY

Photo 4

**Operating instructions:****Cutting off the electricity supply:**

Press the chassis emergency stop.

Starting the electricity supply:



Reset the emergency stop.

7.4 - MAINTENANCE PLAN

The plan (overleaf) indicates frequency, servicing points (device) and the consumables to be used.

- The reference in the symbol indicates the servicing point according to the frequency.
- The symbol represents the consumable to be used (or the operation to be performed).

7.4.1 - Consumables

Consumable	Specification	Symbol	Lubrificiers used by Pinguely-Haulotte	ELF	TOTAL
Hydraulic oil	AFNOR 48602 ISO VG 46		BP SHF ZS 46	HYDRELF DS 46	EQUIVIS ZS 46
Organic hydraulic oil (option) 'Intense cold' hydraulic oil	BIO ISO 46 ISO 6743-4		SHELL TELLUS 32		
Lithium grease			SHELL ALVANIA EP (LF) 3		
Exchange or specific operation					

7.4.1.1 - 'Intense cold' hydraulic oil conditions of use

This oil is meant for working at low temperature.



The ambient temperature must not exceed 15°C. In the opposite case, use a standard or organic hydraulic oil.

7.4.2 - Maintenance diagram

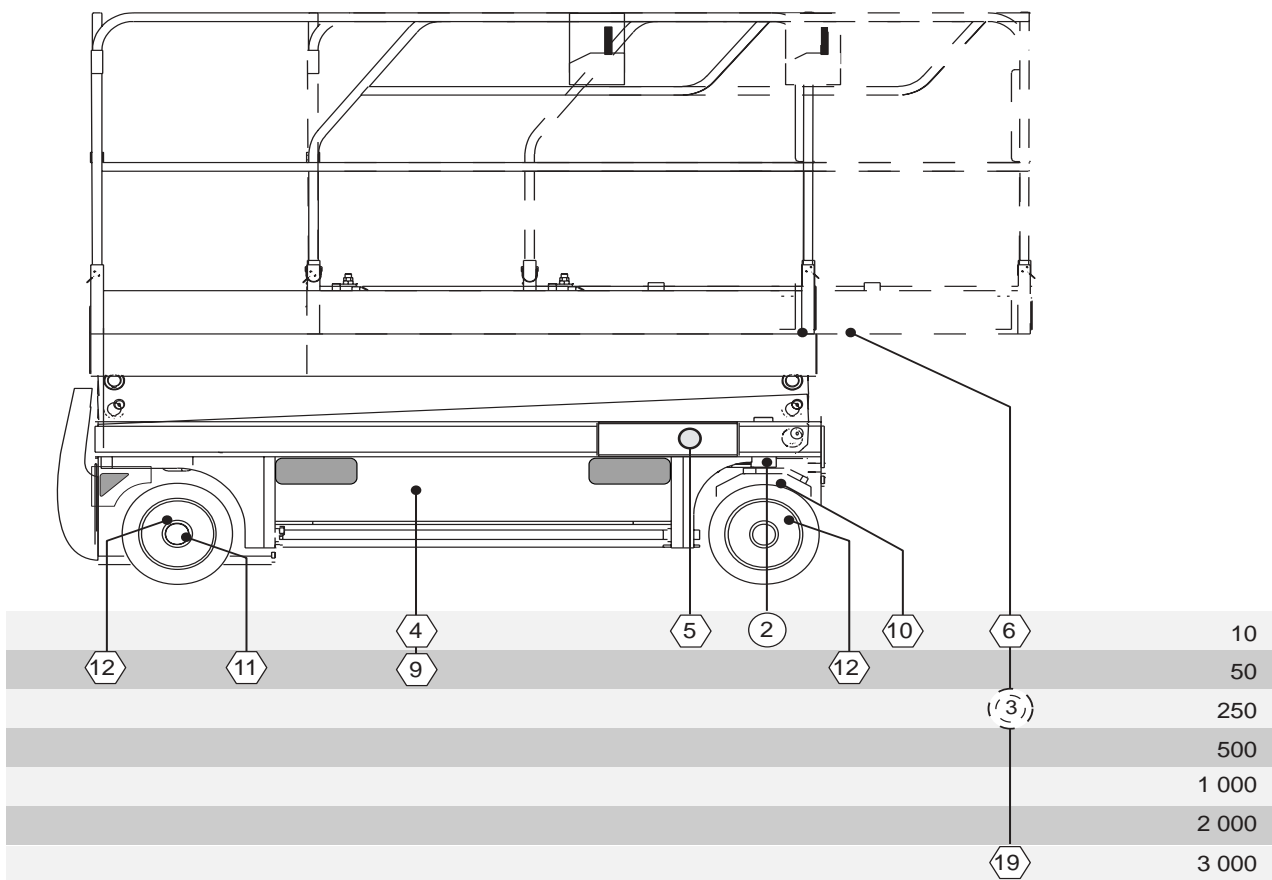
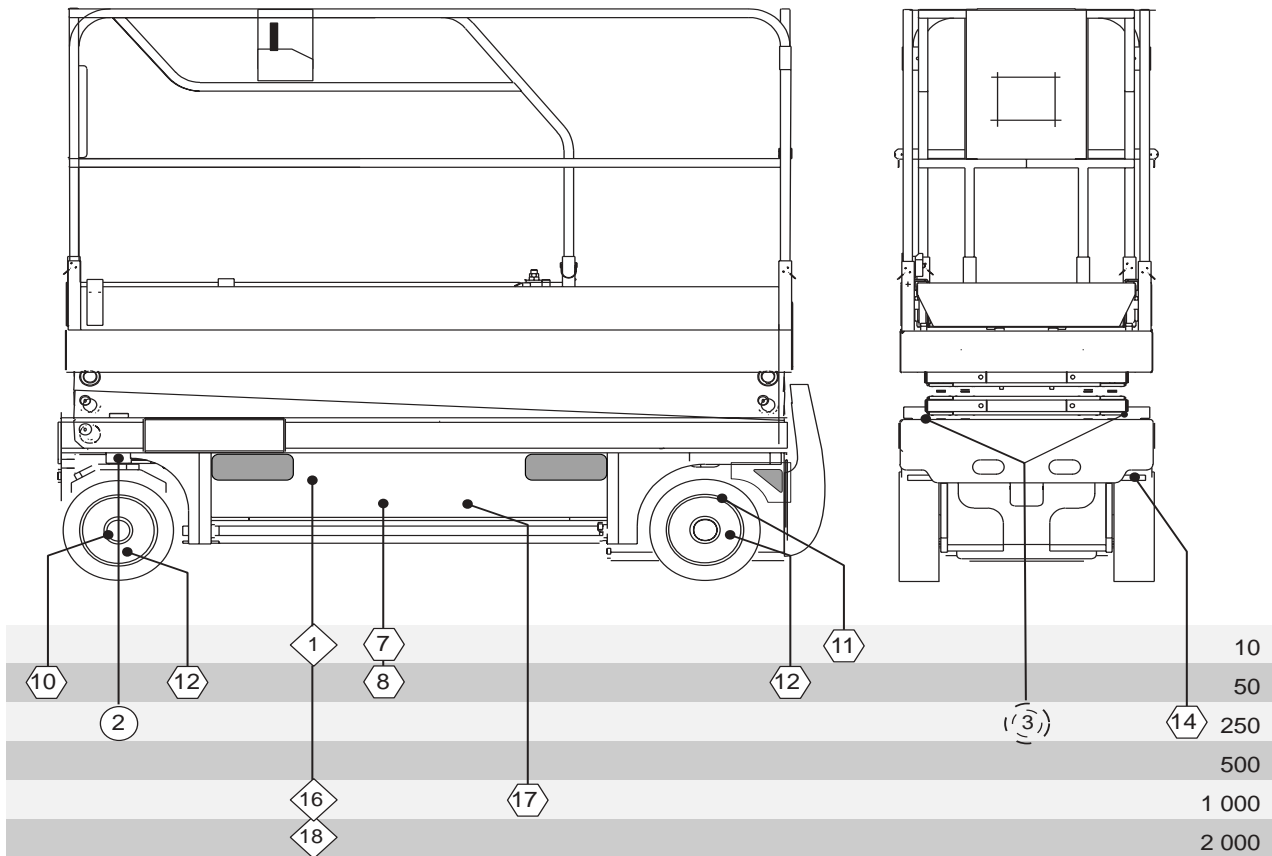

7.5 - OPERATIONS**7.5.1 - Summary table**

IMPORTANT: If "ORGANIC" OR "EXTREME COLD" OIL IS USED, FREQUENCIES IN THE TABLE BELOW ARE REDUCED BY HALF.

FREQUENCY	OPERATIONS	REF	
Every day or before each start of operation	<ul style="list-style-type: none"> • Check the levels: <ul style="list-style-type: none"> - hydraulic oil (see paragraph 8, sheet P001), - electric batteries - battery charge, using the indicator • Check cleanliness: <ul style="list-style-type: none"> - machine (in particular, check the tightness of connections and hoses), also check the condition of tyres, cables and all accessories and equipment. - platform slide for extension • Check hydraulic oil filter clogging. 	1	
		4	
		5	
	Every 50 hours	Pay attention for the first 50 hours: <ul style="list-style-type: none"> • Change the hydraulic oil cartridge (see 250 hours frequency). • Check the condition of battery cables (replace if worn) • Check the tightness: <ul style="list-style-type: none"> - screws in general - front motor fixing screw 9 daNm - rear brake fixing screws 9 daNm - wheel nuts (torque 110 daNm) 	6
			7
			8
			9
Every 250 hours	<ul style="list-style-type: none"> • Change the hydraulic filter cartridge (see paragraph 8, sheet P002) • Grease: <ul style="list-style-type: none"> - steering wheel pivots (see paragraph 8, sheet P003) - the friction parts of the slides with a spatula (see paragraph 8, sheet P004) • Check: <ul style="list-style-type: none"> - battery charger connection - battery level 	10	
		11	
		12	
		13	
		14	
Every 500 hours or every 6 months	<ul style="list-style-type: none"> • If using organic hydraulic oil, empty the hydraulic tank. 	15	
		16	
Every 1000 hours or every year	<ul style="list-style-type: none"> • Empty the hydraulic oil tank • Clean the motor pump set carbon 	16	
		17	
Every 2000 hours	<ul style="list-style-type: none"> • Empty the hydraulic tank and whole hydraulic circuit. 	18	
Every 3000 hours or every 4 years	<ul style="list-style-type: none"> • Check: <ul style="list-style-type: none"> - condition of the slides - condition of the electric cables, hydraulic hoses, etc. 	19	
		20	

REMINDER: All these frequencies must be reduced if working in difficult conditions (consult After-Sales if necessary).

7.6 - PRESENCE OF LABELS

It is important to check that the labels and plates warning personnel of the various dangers associated with using the machine are in good condition.

The labels providing operators with information on machine use and maintenance must also be checked.

An illegible label may lead to incorrect or dangerous use of the machine.

Operating instructions:

Check the presence of the labels:

Check that all the labels described in the operator's manual are legible and in the correct place. Replace if necessary (spare parts can be supplied on request, if necessary).

7.7 - PRESENCE OF MANUALS

It is important to ensure that the manuals supplied with the machine are in good condition and stored in the document holder provided on the platform.

An illegible manual may lead to incorrect or dangerous use of the machine.

Operating instructions:

Check presence of manuals:

Check that all the manuals are legible, complete and stored in the document holder provided on the platform. Replace if necessary (extra copies can be supplied on request by the manufacturer).

8 - PREVENTIVE MAINTENANCE SHEETS

List of preventive maintenance sheets:

<i>Sheet no.</i>	<i>Description</i>
P001	Checking - filling the hydraulic oil tank
P002	Replacing the hydraulic filter cartridge
P003	Greasing the steering wheel pivots
P004	Greasing the slides

SHEET P001	PREVENTIVE MAINTENANCE SHEET	Sheet 1/1
	CHECKING THE HYDRAULIC OIL TANK LEVEL	

1 - Preliminary operations

- Put the machine in the low position and maintenance configuration (see § 7.2, page 49).

 **Caution !**
Ensure that oil temperature is not too high.

NOTA : Do not use the maintenance stands, leave the platform in the low position.

- Cut off the electric power supply (see § 7.3, page 50).

2 - Checking the hydraulic oil tank level

- Ensure that the oil level in the tank is sufficient.
- Top up if necessary.

NOTA : Only use the oil recommended by the manufacturer.

- Put the machine back into operational configuration.



MAX MIN



OIL LEVEL

	PREVENTIVE MAINTENANCE SHEET	

<i>SHEET P002</i>	PREVENTIVE MAINTENANCE SHEET	Sheet 1/1
	REPLACING THE HYDRAULIC FILTER CARTRIDGE	

 **Caution !**
Ensure that oil temperature is not too high.

1 - Preliminary operations

- Put the machine in the maintenance configuration (see § 7.2, page 49).
- Cut off the electric power supply (see § 7.3, page 50).

2 - Replacing the hydraulic filter cartridge

- Unscrew the body and remove the hydraulic filter cartridge.
- Screw a new cartridge into place.
- Put the machine back into the operational configuration.



Compact



Optimum

	PREVENTIVE MAINTENANCE SHEET	

<i>SHEET P003</i>	PREVENTIVE MAINTENANCE SHEET	Sheet 1/1
	GREASING THE STEERING WHEEL PIVOTS	

1 - Greasing the steering wheel pivots



Compact, optimum, previous design

- Cut off the electric power supply (see § 7.3, page 52).
- Grease the pivots.

NOTA : *Only use the grease recommended by the manufacturer.*

- Put the machine back into the operational configuration



Compact, optimum, current design



Star 22J / Star 8

	PREVENTIVE MAINTENANCE SHEET	

<i>SHEET P004</i>	PREVENTIVE MAINTENANCE SHEET	Sheet 1/1
	GREASING THE SLIDES	

1 - Preliminary operations



- Put the machine in the maintenance configuration (see § 7.2, page 51).
- Cut off the electric power supply (see § 7.3, page 52).

2 - Greasing the slides

- Grease the slides using a spatula.

NOTA : *Only use the grease recommended by the manufacturer.*

- Put the machine back into the operational configuration.

	PREVENTIVE MAINTENANCE SHEET	

9 - OPERATING INCIDENTS

9.1 - TABLE OF INCIDENTS

Before anything else, check that:

- the batteries are charged; the green light indicators should be on.
- the two "palm button" emergency stops on the chassis control box and on the platform control box are unlocked.
- the oil level in the tank is OK.



Caution!

**Bubbles + pressure + heat = unacceptable situation.
Risk of explosion**

NB: Cavitation (emulsified oil) may cause incorrect operation of hydraulic components. It takes approximately 4 hours for oil that has been emulsified under the effects of cavitation to get back to its normal condition.

9.1.1 - General operation

ANOMALY	CHECK	PROBABLE CAUSE	SOLUTION
No movement		<ul style="list-style-type: none"> • Defective batteries • Oil level low • Defective fuses • Defective chassis emergency stop • Defective platform emergency stop • Defective wiring harness • Defective motorpump set • Defective printed circuit • Defective control unit 	SHEET DP007
Hydraulic pump noisy		<ul style="list-style-type: none"> • Insufficient oil in the tank • Defective pump 	SHEET DP009
Pothole system does not extend when the platform is raised		<ul style="list-style-type: none"> • Defective speed variator • Defective wiring harness • Defective electrovalve YV6 coil • Defective electrovalve YV6 • Defective pothole cylinders 	SHEET DP013
No movement from the platform control station		<ul style="list-style-type: none"> • Defective key switch SA1 • Defective electric wiring harness • Defective speed variator • Defective manipulator • Defective printer circuit U2 	SHEET DP014
Hydraulic pump cavitation (Vacuum in the pump due to insufficient oil).	The hydraulic oil becomes cloudy and white (with bubbles)	<ul style="list-style-type: none"> • Oil viscosity too high 	<ul style="list-style-type: none"> • Empty the circuit and refill with the recommended oil.

ANOMALY	CHECK	PROBABLE CAUSE	SOLUTION
Overheating of the hydraulic circuit		<ul style="list-style-type: none"> • Oil viscosity too high • Insufficient hydraulic oil in the tank 	<ul style="list-style-type: none"> • Empty the circuit and replace with the recommended oil. Top up with oil as necessary.
The system works irregularly		<ul style="list-style-type: none"> • The hydraulic oil is not at optimum operating temperature 	<ul style="list-style-type: none"> • Make some movements without load to enable the oil to heat up

9.1.2 - Platform lifting system

ANOMALY	CHECK	PROBABLE CAUSE	SOLUTION
No up or down movement from the platform control		<ul style="list-style-type: none"> • Defective wiring harness • Defective printed circuit U2 • Defective manipulator • Defective platform emergency stop button • Defective speed variator 	SHEET DP001
No up or down movement from the chassis control		<ul style="list-style-type: none"> • Defective key switch • Defective wire no. 10 • Defective switch SA2 • Defective speed variator 	SHEET DP002
No up movement from the chassis or platform controls		<ul style="list-style-type: none"> • Hydraulic leak • Defective wiring harness • Defective electrovalve YV1 coil • Defective lifting cylinder • Defective electrovalve YV1 • Defective or badly adjusted limiter • Defective tilt detector • Defective speed variator • Defective end of stroke contactor 	SHEET DP003
No down movement from the platform or chassis controls		<ul style="list-style-type: none"> • Defective wiring harness • Badly adjusted or defective pressure contact SP1 • Defective electrovalve YV7 coil • Defective electrovalve YV7 • Defective speed variator 	SHEET DP004
The platform (above 1.5m) comes down slowly by platform or chassis controls		<ul style="list-style-type: none"> • Defective electrovalve YV9 coil • Defective electrovalve YV9 • Defective electric wiring harness • Defective speed variator 	SHEET DP061
The platform moves up and down with a jerky movement		<ul style="list-style-type: none"> • Insufficient oil in the hydraulic circuit 	<ul style="list-style-type: none"> • Top up with oil as necessary

9.1.3 - Travel system

ANOMALY	CHECK	PROBABLE CAUSE	SOLUTION
No travel movement in either direction, FORWARD or BACKWARD		<ul style="list-style-type: none"> • No movement available • Defective pothole cylinder • Defective wiring harness • Defective pothole end of stroke contactor • Defective brake • Defective motor 	SHEET DP062
No travel in one direction, FORWARD or BACKWARD		<ul style="list-style-type: none"> • Defective speed variator • Defective wiring harness • Defective YV2a or YV2b coil 	SHEET DP010
High speed unavailable below 1.5m		<ul style="list-style-type: none"> • Defective electrovalve YV3 or YV4 coil • Defective electrovalve YV3 or YV4 • Defective wiring harness • Defective printed circuit U2 • Defective speed selector switch SA3 	SHEET DP011
Only micro-speed is available below 1.5m		<ul style="list-style-type: none"> • Defective speed variator • Defective electric wiring harness • Defective contactor SQ1 	SHEET DP012
The machine goes into runaway downhill		<ul style="list-style-type: none"> • Balancing valve incorrectly set or not working properly 	<ul style="list-style-type: none"> • Replace the balancing valve.

9.1.4 - Steering system

ANOMALY	CHECK	PROBABLE CAUSE	SOLUTION
No steering		<ul style="list-style-type: none"> • Hydraulic leak • No lifting • Defective printed circuit U2 • Defective electrovalve YV5a or YV5b coil • Defective electrovalve YV5 • Defective wiring harness • Defective manipulator • Defective steering cylinder • Defective steering pressure limiter 	SHEET DP008

9.1.5 - List of MDI codes

Alarm code	Number of flashes (MDI)	Message	Description	Solution
AL01	3	EVP NOT OK	<ul style="list-style-type: none"> Defective coil or YV7/YV9 coil's supply. 	<ul style="list-style-type: none"> Look for failure on the lifting cylinders' lowering coil(s).
AL06	6	SERIAL ERROR #1	<ul style="list-style-type: none"> Incorrect or lack of reception of serial card's signal to chopper. 	<ul style="list-style-type: none"> Look for failure on: <ul style="list-style-type: none"> the platform console's serial card; the bundle; the connections between the platform's console and the chopper. Other possible reason: incorrect cabling on the MDI line or the MDI display.
AL13	6	EEPROM KO	<ul style="list-style-type: none"> Fault in the chopper's EEPROM. 	<ul style="list-style-type: none"> Replace the chopper.
AL32	3	VMN NOT OK	<ul style="list-style-type: none"> Low VMN at rest or inconsistent with the applied VMN at work. 	<ul style="list-style-type: none"> Check the chopper's isolation between B- and P terminals. If the value is below 65 KOhms, replace the chopper. Otherwise replace the motor.
AL37	4	CONTACTOR CLOSED	<ul style="list-style-type: none"> SB1's contact stuck. 	<ul style="list-style-type: none"> Check SB1.
AL38	4	CONTACTOR OPEN	<ul style="list-style-type: none"> SB1's auxiliary contact faulty. 	<ul style="list-style-type: none"> Check SB1.
AL49	5	I=O EVER	<ul style="list-style-type: none"> Null current on movement request. 	<ul style="list-style-type: none"> Replace the chopper.
AL53	5	STBY I HIGH	<ul style="list-style-type: none"> High current at rest. 	<ul style="list-style-type: none"> Replace the chopper.
AL60	3	CAPACITOR CHARGE	<ul style="list-style-type: none"> Capacitors do not charge on starting the machine. 	<ul style="list-style-type: none"> Replace the chopper.
AL62	9	TH. PROTECTION	<ul style="list-style-type: none"> Chopper's thermal protection: temperature over 75°C/167F 	<ul style="list-style-type: none"> Replace the chopper.
AL66	8	BATTERY LOW	<ul style="list-style-type: none"> Batteries discharged. 	<ul style="list-style-type: none"> Check: <ul style="list-style-type: none"> the batteries the charger the electric circuit's supply.
AL73	1	POWER FAILURE	<ul style="list-style-type: none"> Short circuit on an electrovalve's coil or the horn or SB1's coil. 	<ul style="list-style-type: none"> Check: <ul style="list-style-type: none"> the electrovalves' various coils, the horn; SB1 contactor's coil.
AL74	4	DRIVER SHORTED	<ul style="list-style-type: none"> SB1 contactor's driver faulty or in short circuit. 	<ul style="list-style-type: none"> Defective SB1 or chopper.
AL75	4	CONTACTOR DRIVER	<ul style="list-style-type: none"> SB1 contactor's driver malfunctioning or will not close. 	<ul style="list-style-type: none"> Defective SB1 or chopper.

Alarm code	Number of flashes (MDI)	Message	Description	Solution
AL78	2	VACC NOT OK	<ul style="list-style-type: none"> Manipulator at rest. 	<ul style="list-style-type: none"> Check the joystick's output voltage using the console's TESTER mode. In the case of an incorrect programming, adjust the values calibrating the serial card. Otherwise replace the chopper.
AL79	2	INCORRECT START	<ul style="list-style-type: none"> Incorrect starting sequence. 	<ul style="list-style-type: none"> Check the joystick's output data using the console's TESTER mode, then replace either the joystick or the chopper, according to the tests' results.
AL80	2	FORW+BACK	<ul style="list-style-type: none"> Backward and forward movements requested simultaneously. 	<ul style="list-style-type: none"> Check the joystick's output data using the console's TESTER mode, then replace either the joystick or the chopper, according to the tests' results.
AL90	4	DRIVER 1 KO	<ul style="list-style-type: none"> YV6 coil in short circuit. 	<ul style="list-style-type: none"> Check YV6 electrovalve's coil and its connections.
AL93	0	WRONG INPUT CONF.	<ul style="list-style-type: none"> The platform console's ENABLE starting switch is closed while a movement is requested from the chassis control panel. 	<ul style="list-style-type: none"> Replace the chassis control panel's lift switch.
AL94	6	MICRO CONTROL KO	<ul style="list-style-type: none"> The Siemens calculator does not respond correctly. 	<ul style="list-style-type: none"> Replace the chopper.
AL97	5	CURR. PROTECTION	<ul style="list-style-type: none"> Current out of control. 	<ul style="list-style-type: none"> Replace the chopper.
AL98	0		<ul style="list-style-type: none"> The hour shown on the MDI and the chopper differ. 	<ul style="list-style-type: none"> Wait for 6 minutes after putting into service. If the problem remains, connect the console instead of the MDI. In this configuration, if the machine functions again, MDI fault. If the machine still does not function, defective bundle or chopper.
AL99	6	CHECK UP NEEDED	<ul style="list-style-type: none"> The 'Check up' function has been activated. 	<ul style="list-style-type: none"> Deactivate the 'CHECK UP ENABLE' function using the console.

NB: If no situation and red and green (last) light indicators are on, SPEED VARIATOR is INOPERATIVE.

Alarm 01:- if all the green light indicators are on = speed variator inoperative

- Check YV7 connector
- Disconnect the plug on electrovalve YV7
- Take YV1 coil for testing
- The fault disappears = replace coil / the fault does not disappear
- Disconnect the plug connecting with the chassis wiring harness
- Check the pin of wire 26 for incorrect connection
- Tests

Alarm 98 :- when replacing the speed variator or MDI, this code may appear when restarting the machine. In this case, leave the machine live for approximately 1/4 hour, to allow the speed variator to re-establish communication with the M.D.I.

9.2 - FAILURE DETECTION FLOW CHARTS

SHEET DP001	FAILURE DETECTION FLOW CHART	Sheet 1/2
	NO UP AND DOWN MOVEMENT FROM THE PLATFORM CONTROL	

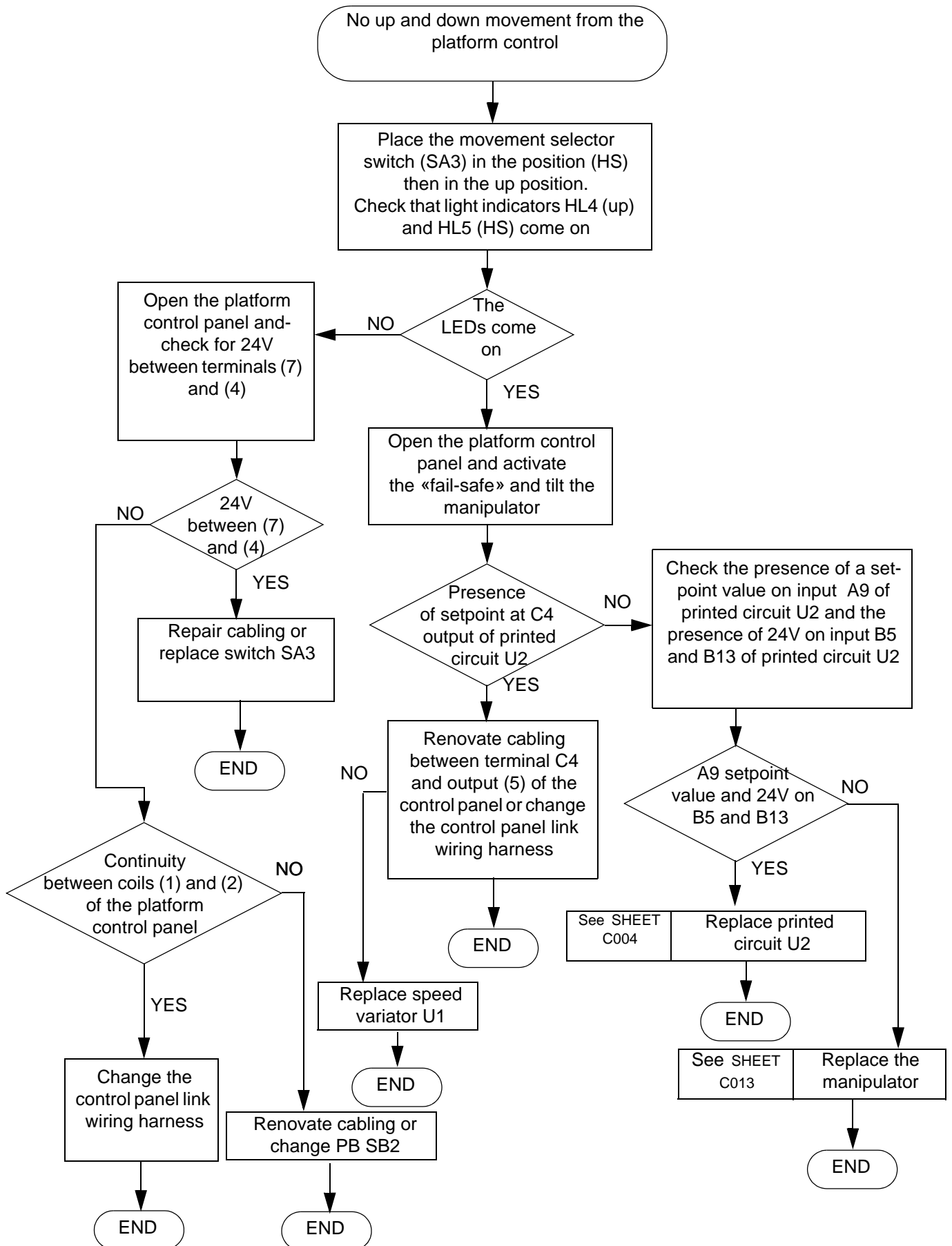

SHEET DP001	FAILURE DETECTION FLOW CHART	Sheet 2/2
	NO UP AND DOWN MOVEMENT FROM THE PLATFORM CONTROL	

SHEET DP002	FAILURE DETECTION FLOW CHART	Sheet 1/2
	NO UP AND DOWN MOVEMENT FROM THE CHASSIS CONTROL	

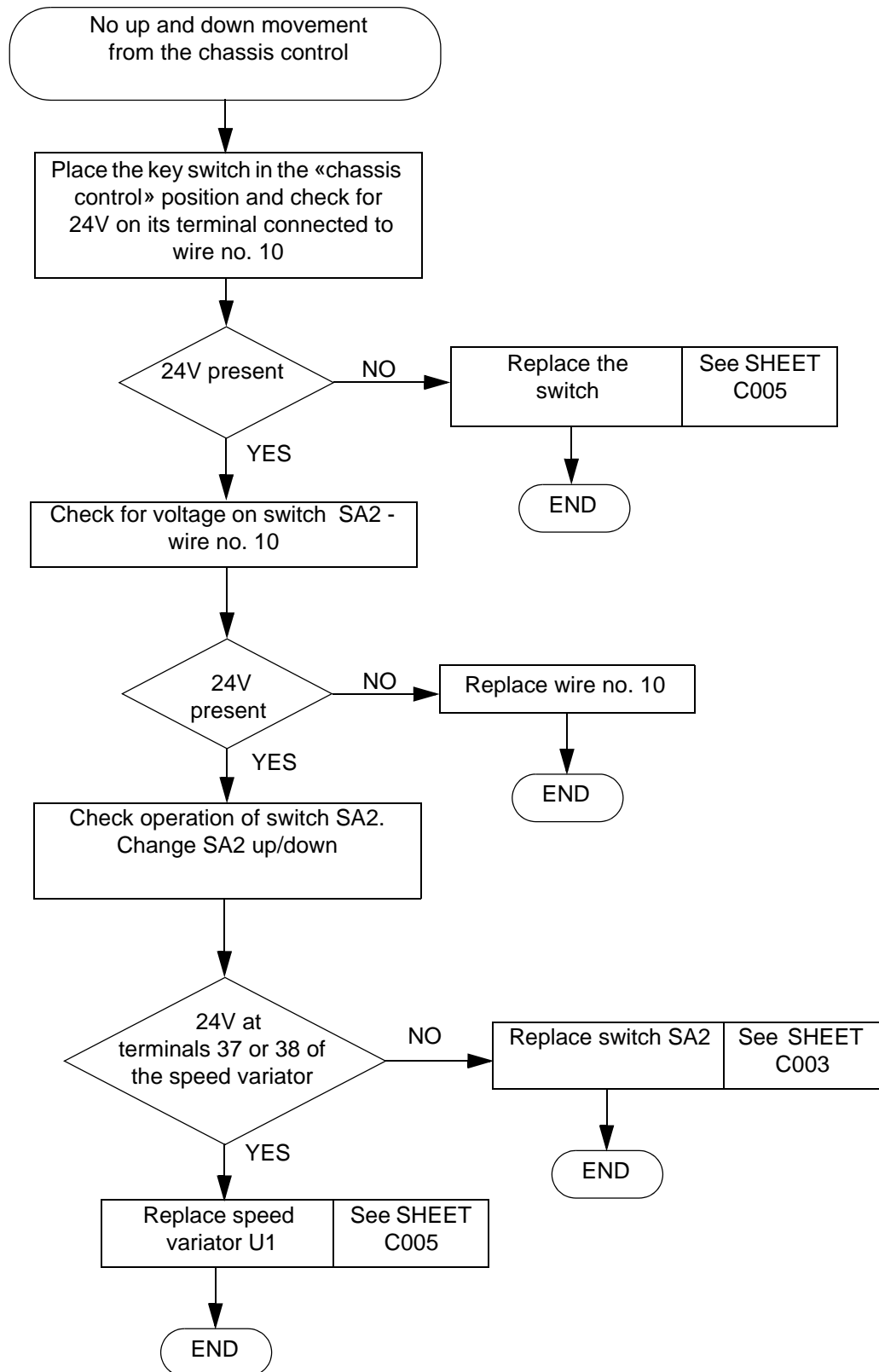

SHEET DP002	FAILURE DETECTION FLOW CHART	Sheet 2/2
	NO UP AND DOWN MOVEMENT FROM THE CHASSIS CONTROL	

SHEET DP003	FAILURE DETECTION FLOW CHART	Sheet 1/4
	NO UP MOVEMENT FROM THE CHASSIS OR PLATFORM CONTROL	

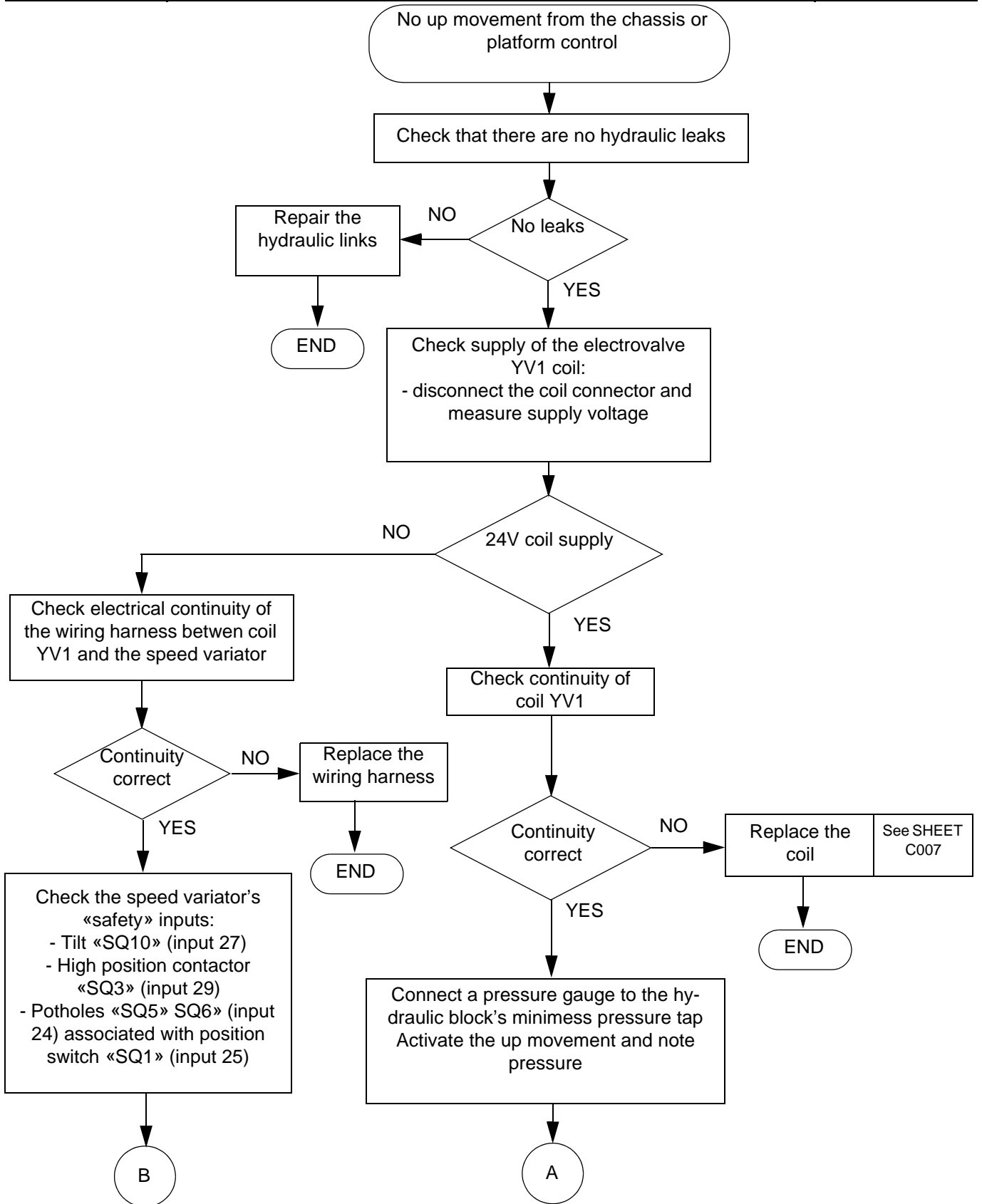

SHEET DP003	FAILURE DETECTION FLOW CHART	Sheet 2/4
	NO UP MOVEMENT FROM THE CHASSIS OR PLATFORM CONTROL	

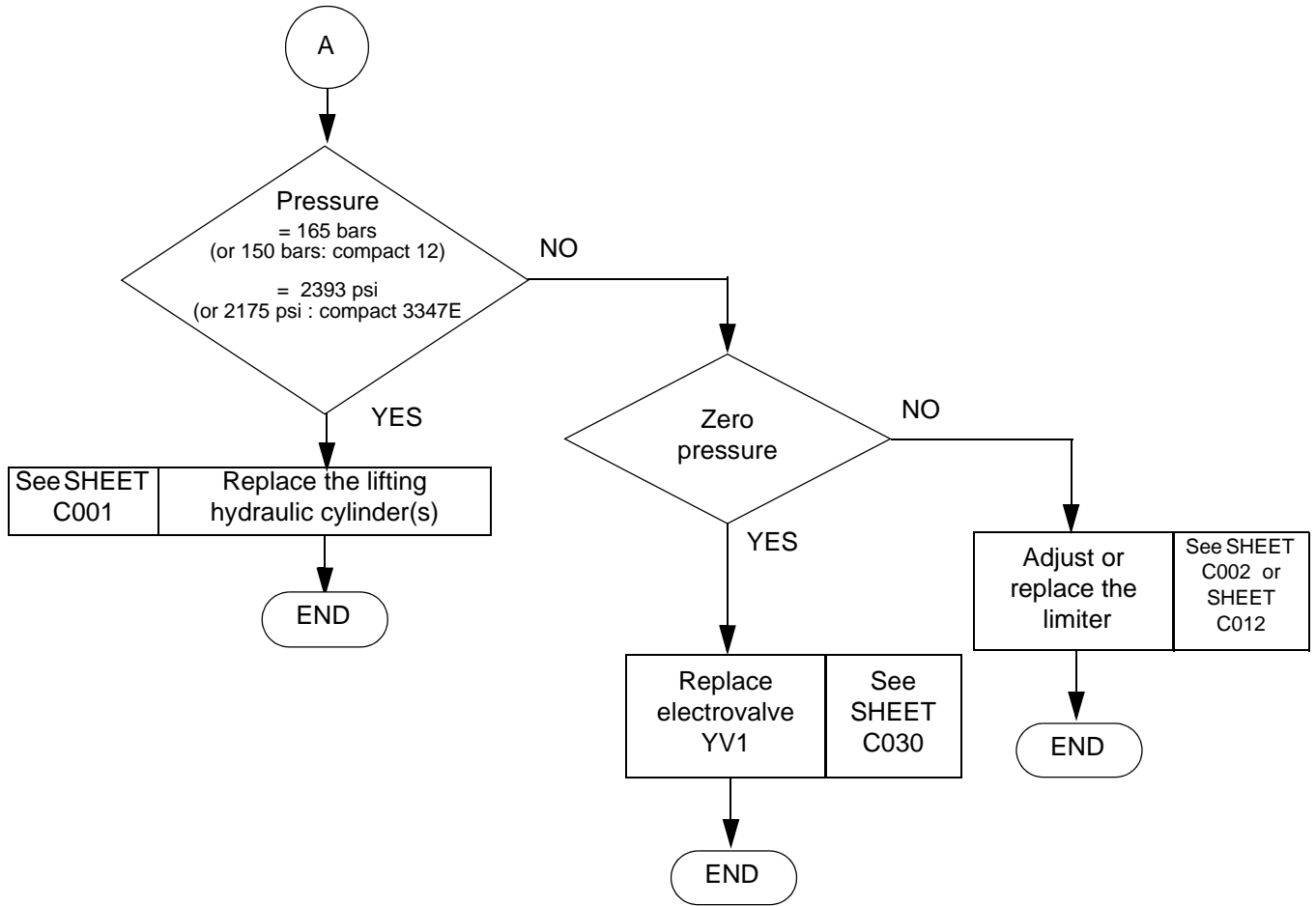

SHEET DP003	FAILURE DETECTION FLOW CHART	Sheet 3/4
	NO UP MOVEMENT FROM THE CHASSIS OR PLATFORM CONTROL	

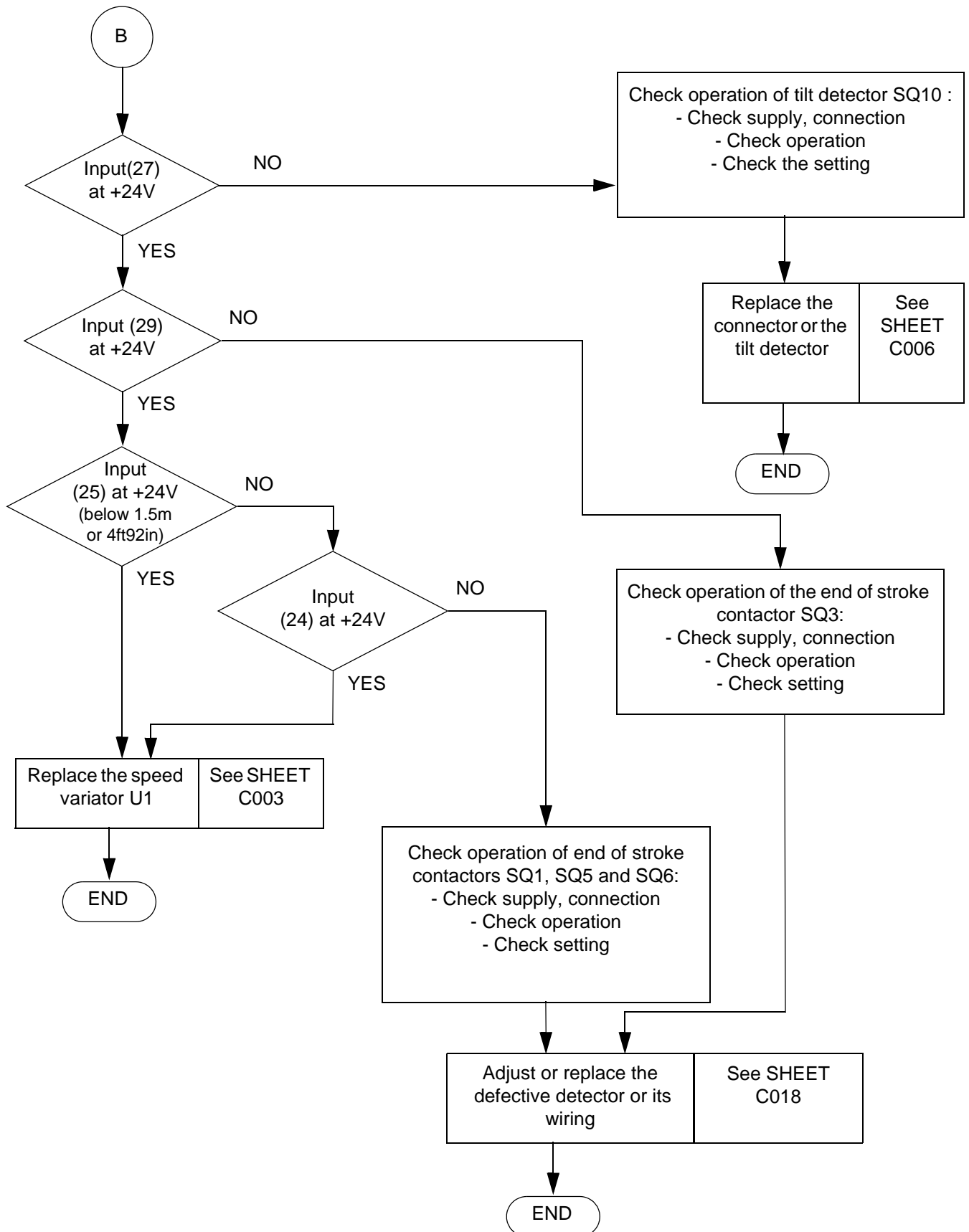

<i>SHEET DP003</i>	FAILURE DETECTION FLOW CHART	Sheet 4/4
	NO UP MOVEMENT FROM THE CHASSIS OR PLATFORM CONTROL	

SHEET DP004	FAILURE DETECTION FLOW CHART	Sheet 1/2
	NO DOWN MOVEMENT FROM THE PLATFORM OR CHASSIS CONTROL	

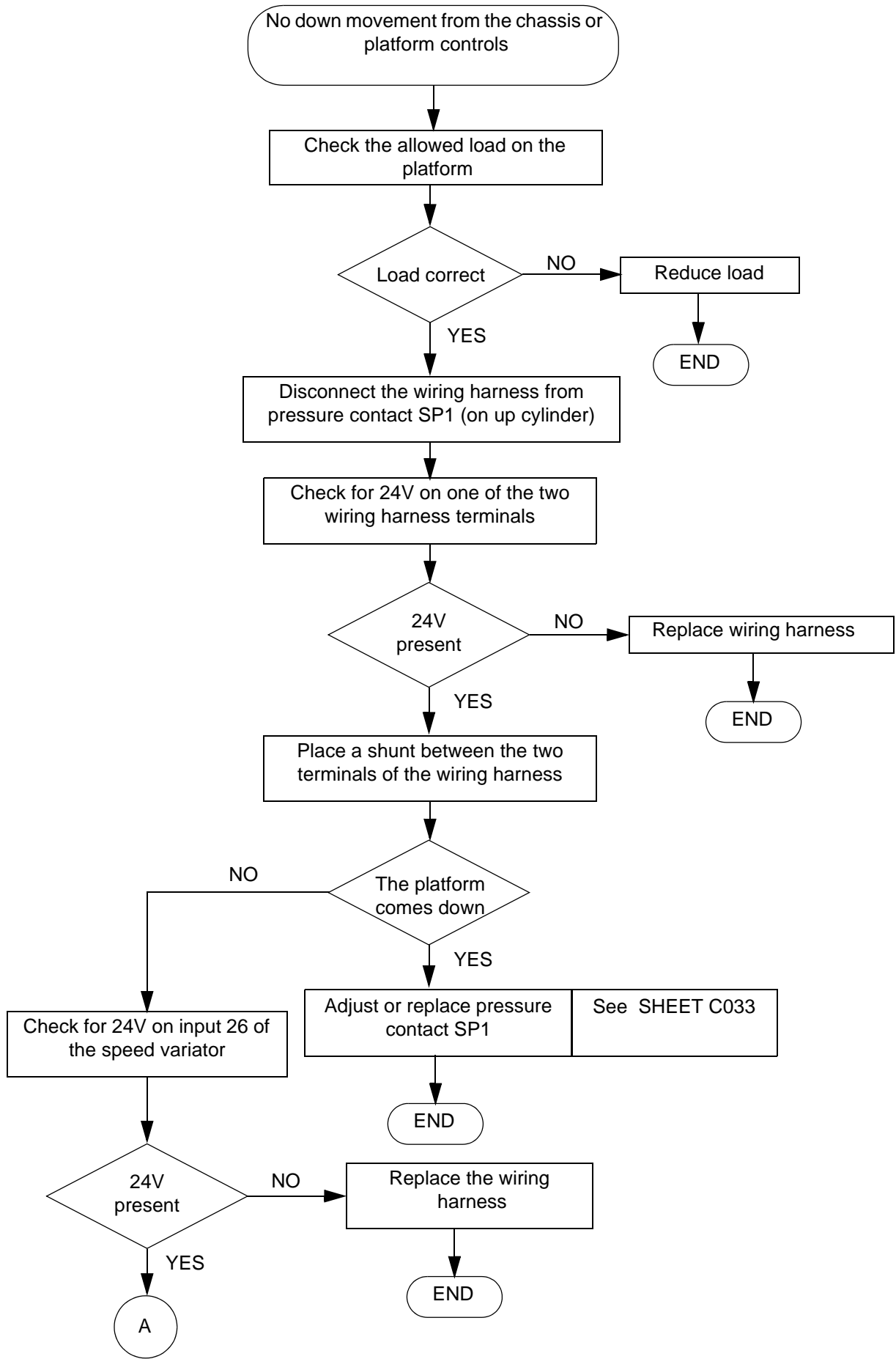

SHEET DP004	FAILURE DETECTION FLOW CHART	Sheet 2/2
	NO DOWN MOVEMENT FROM THE PLATFORM OR CHASSIS CONTROL	

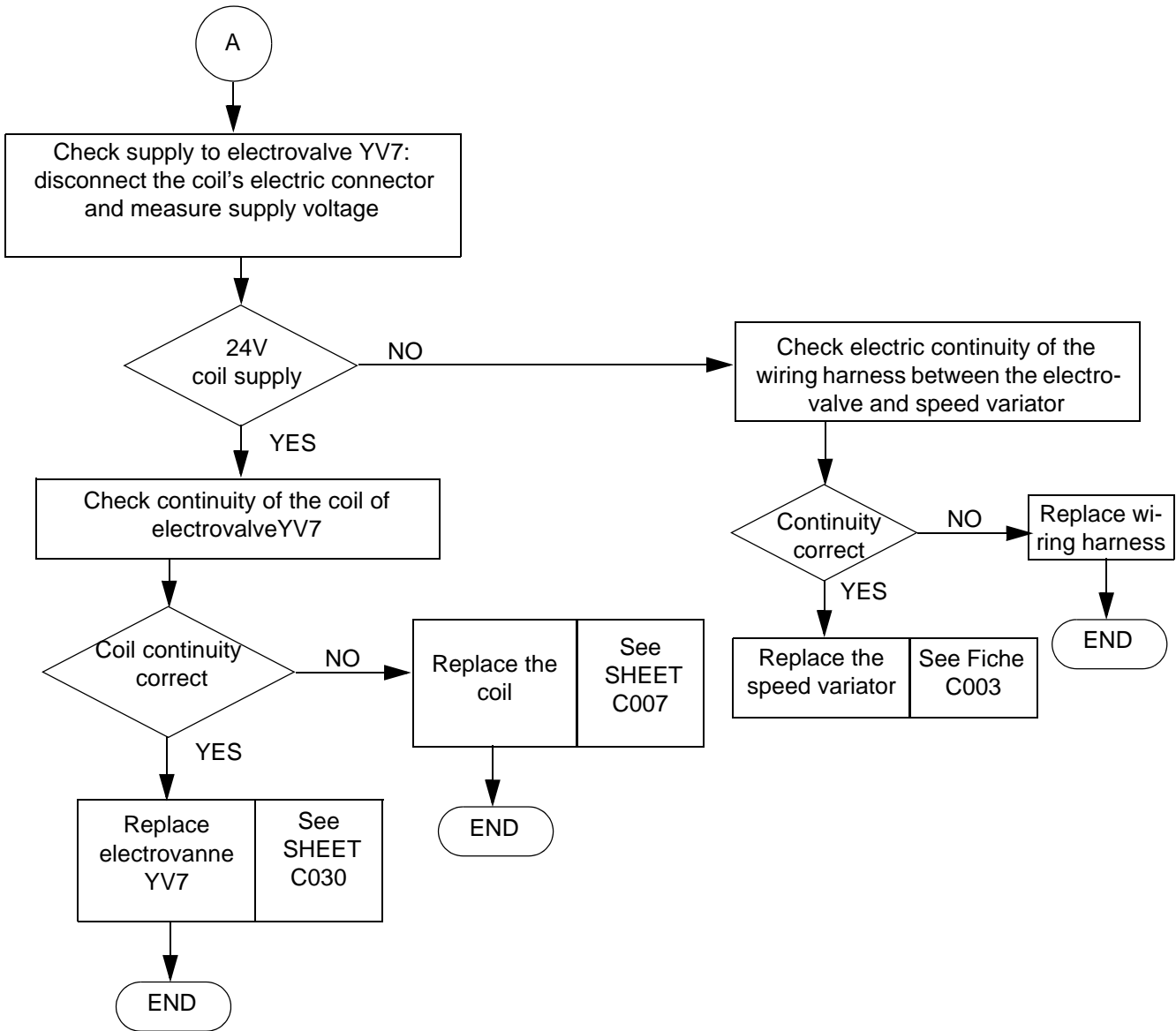

SHEET DP007	FAILURE DETECTION FLOW CHART	Sheet 1/4
	NO MOVEMENT	

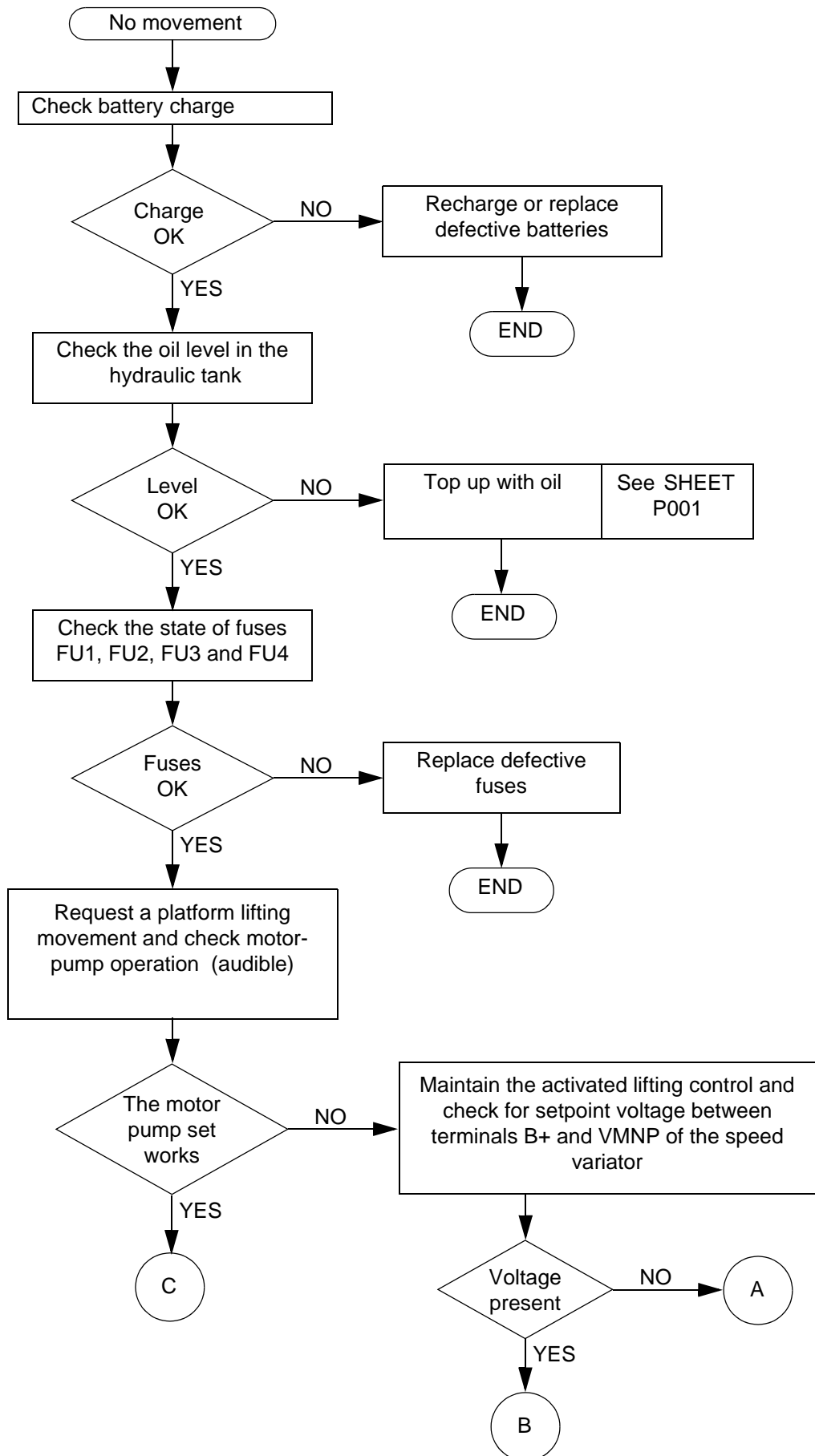

SHEET DP007	FAILURE DETECTION FLOW CHART	Sheet 2/4
	NO MOVEMENT	

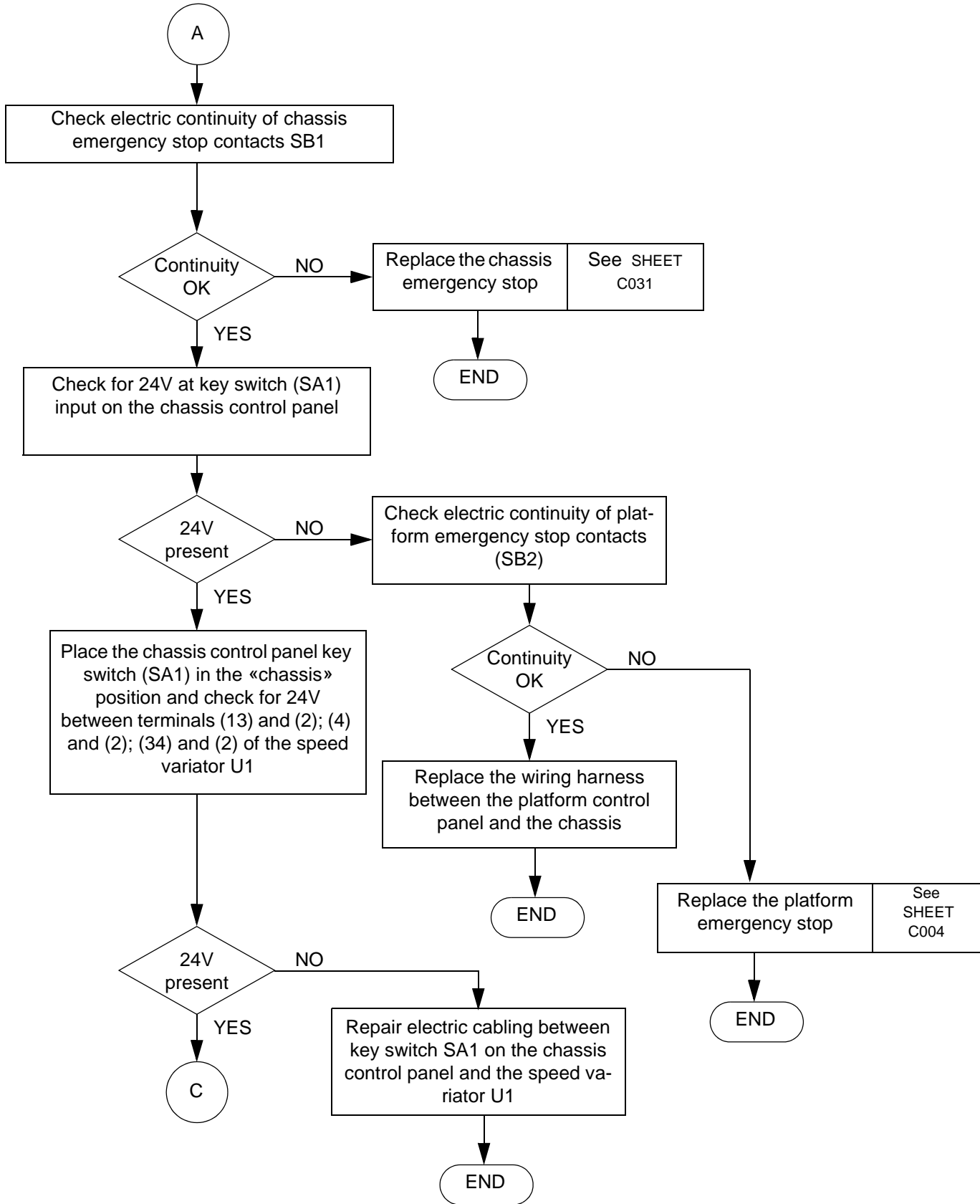

SHEET DP007	FAILURE DETECTION FLOW CHART	Sheet 3/4
	NO MOVEMENT	

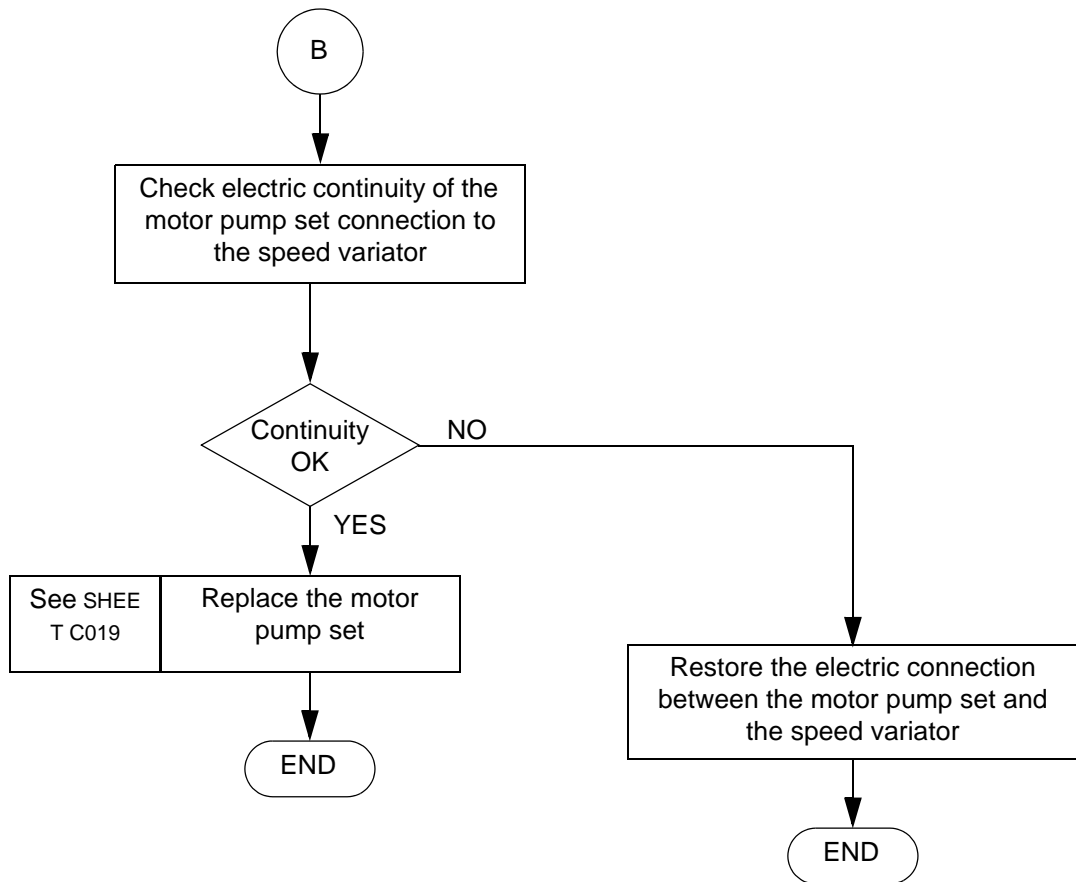

SHEET DP007	FAILURE DETECTION FLOW CHART	Sheet 4/4
	NO MOVEMENT	

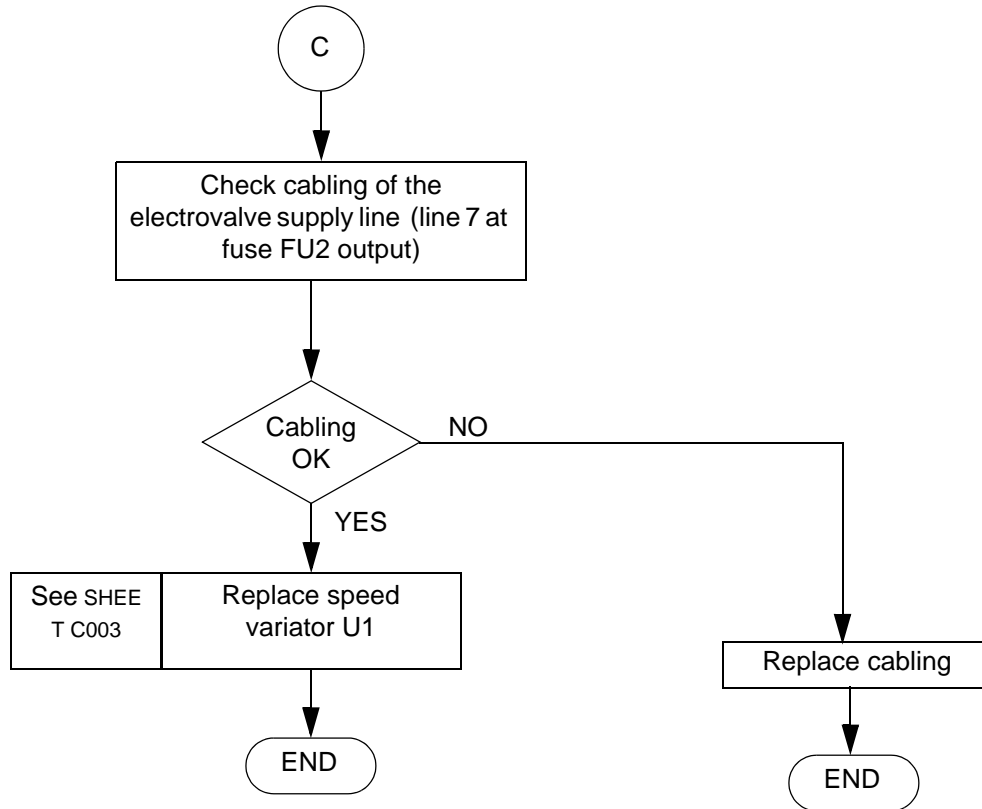

SHEET DP008	FAILURE DETECTION FLOW CHART	Sheet 1/2
	NO STEERING	

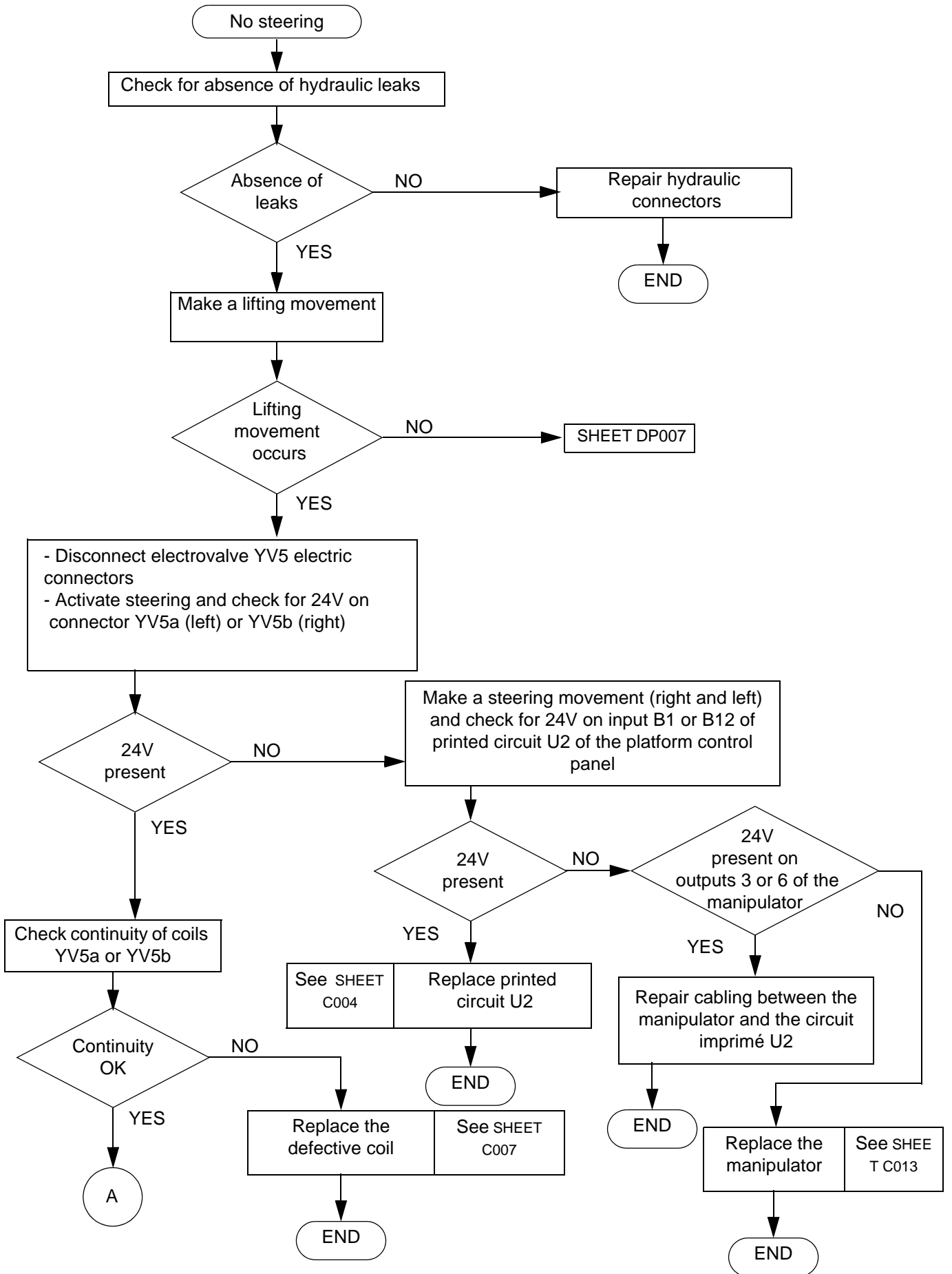

SHEET DP008	FAILURE DETECTION FLOW CHART	Sheet 2/2
	NO STEERING	



Connect a pressure gauge to the minimes tapping on the hydraulic block
Activate steering and note the pressure value (value disappears after 5s)

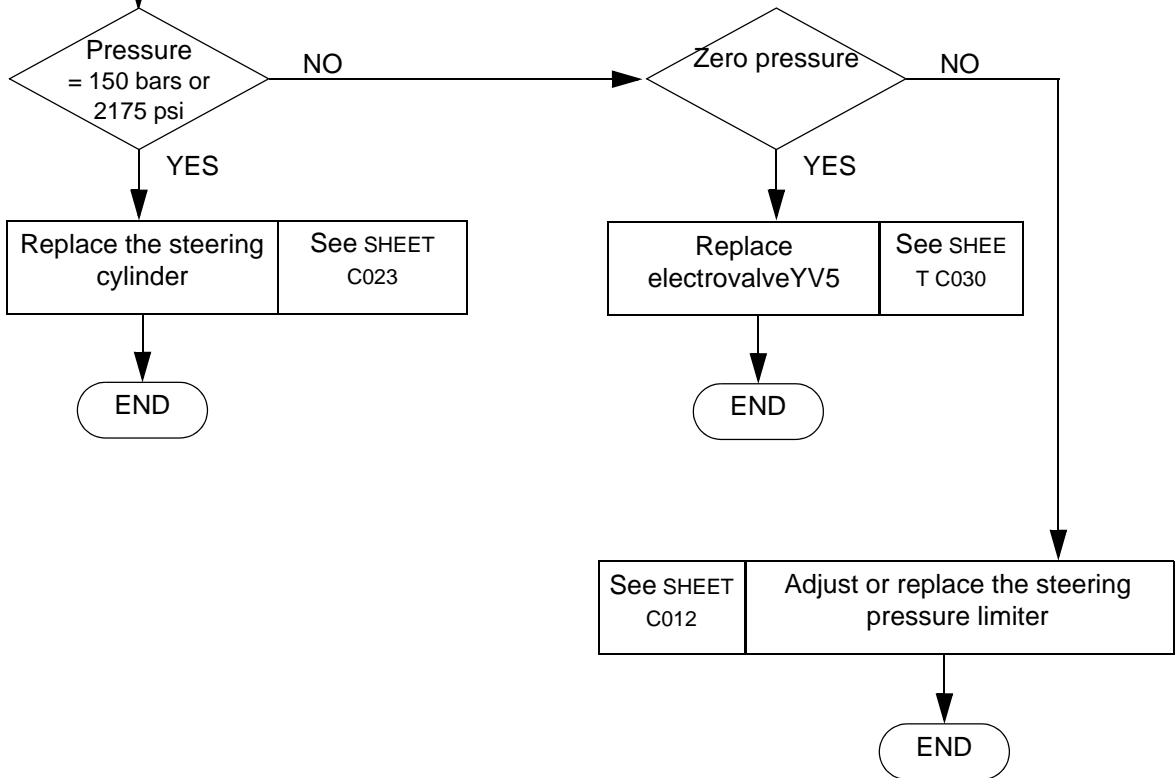

SHEET DP009	FAILURE DETECTION FLOW CHART	Sheet 1/2
	NOISY HYDRAULIC PUMP	

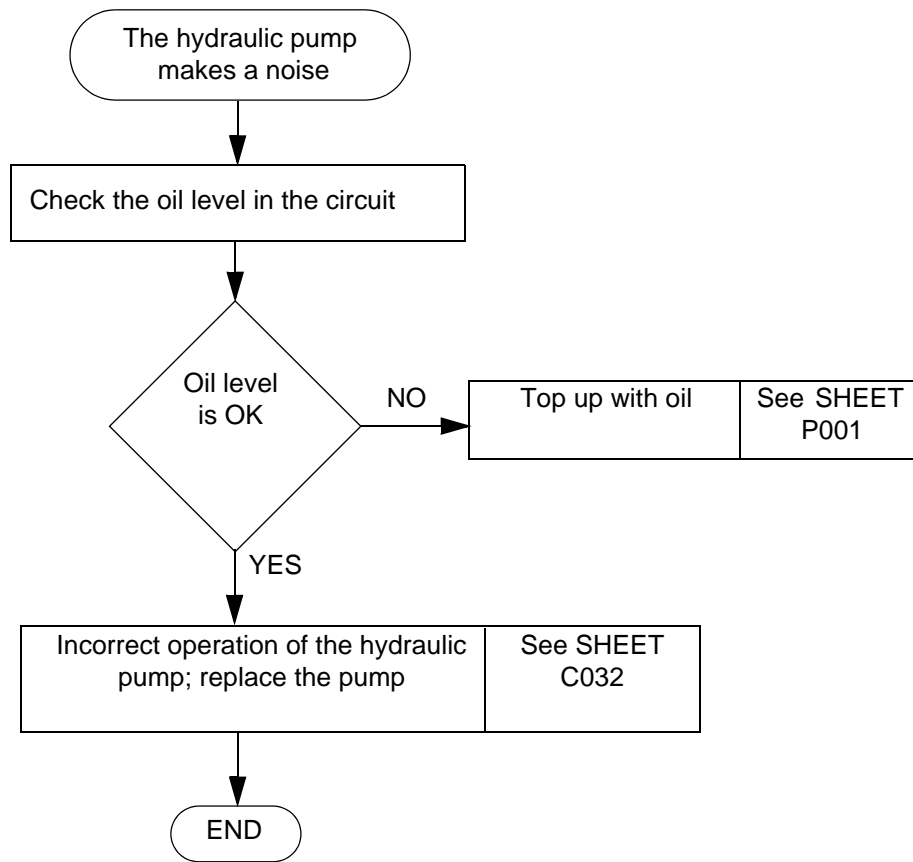

SHEET DP009	FAILURE DETECTION FLOW CHART	Sheet 2/2
	NOISY HYDRAULIC PUMP	

SHEET DP010	FAILURE DETECTION FLOW CHART	Sheet 1/2
	NO TRAVEL IN JUST ONE DIRECTION	

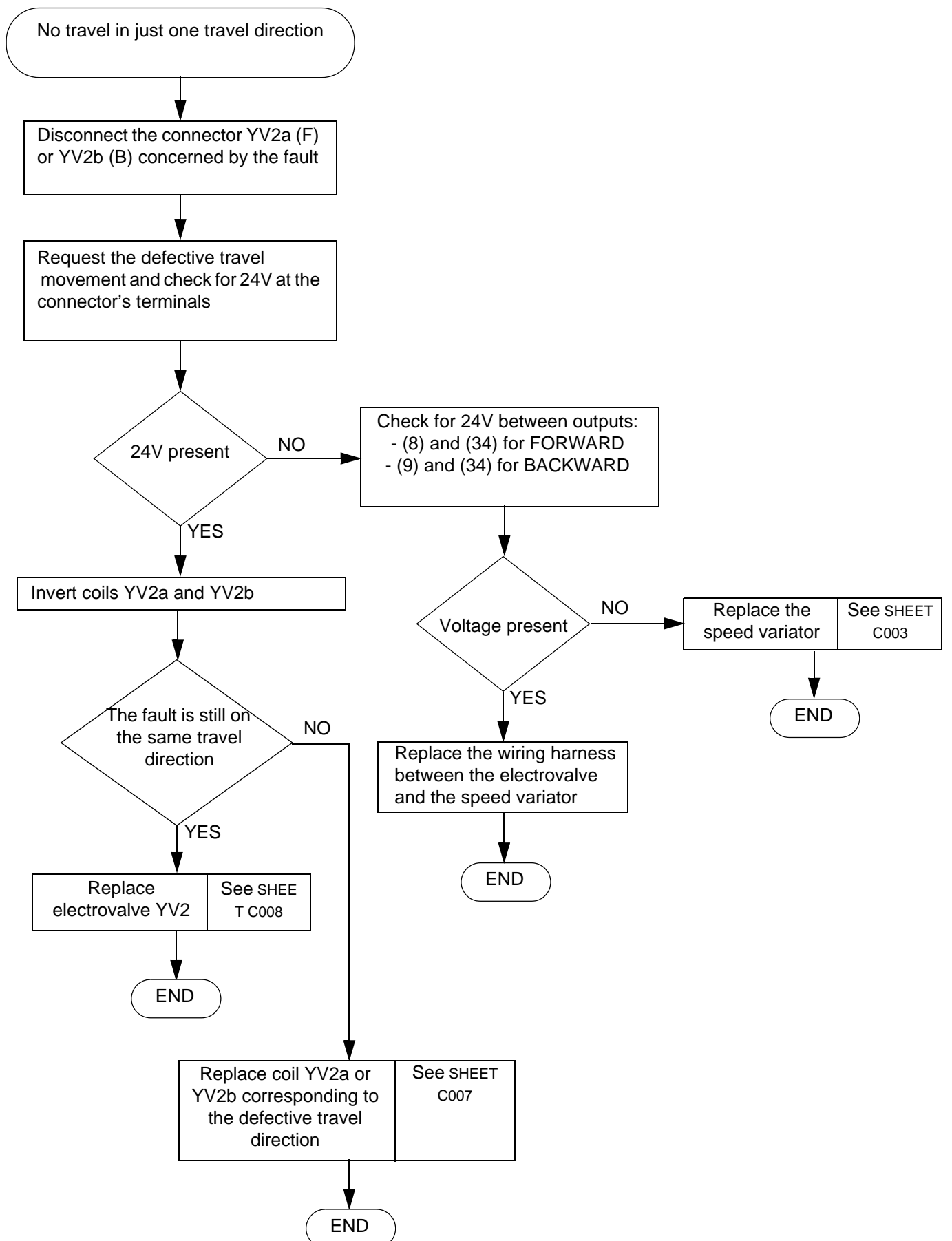

SHEET DP010	FAILURE DETECTION FLOW CHART	Sheet 2/2
	NO TRAVEL IN JUST ONE DIRECTION FORWARD or BACKWARD	

SHEET DP011	FAILURE DETECTION FLOW CHART	Sheet 1/2
	HIGH SPEED UNAVAILABLE BELOW 1.5M OR 4FT92IN	

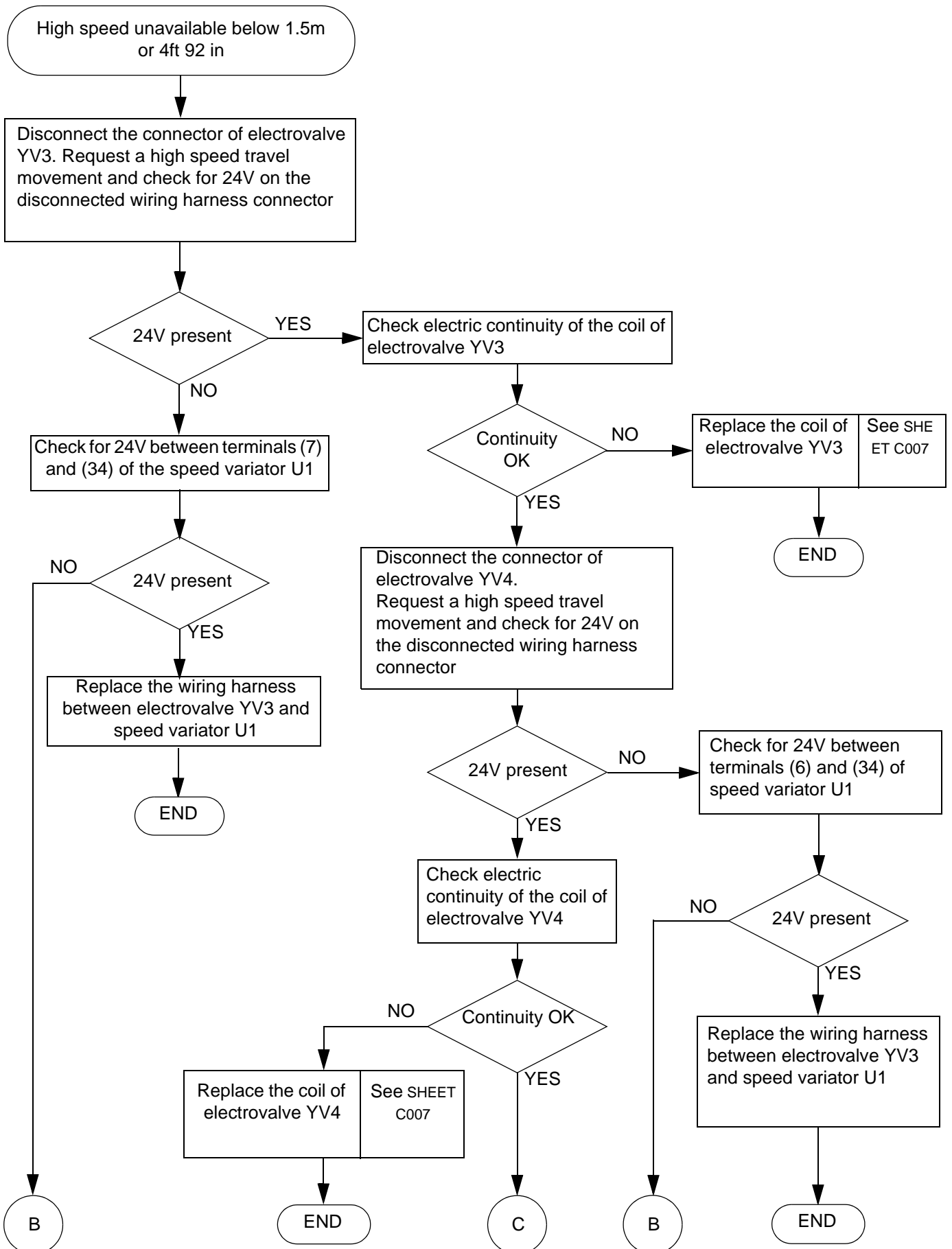

SHEET DP011	FAILURE DETECTION FLOW CHART	Sheet 2/2
	HIGH SPEED UNAVAILABLE BELOW 1.5M OR 4FT92IN	

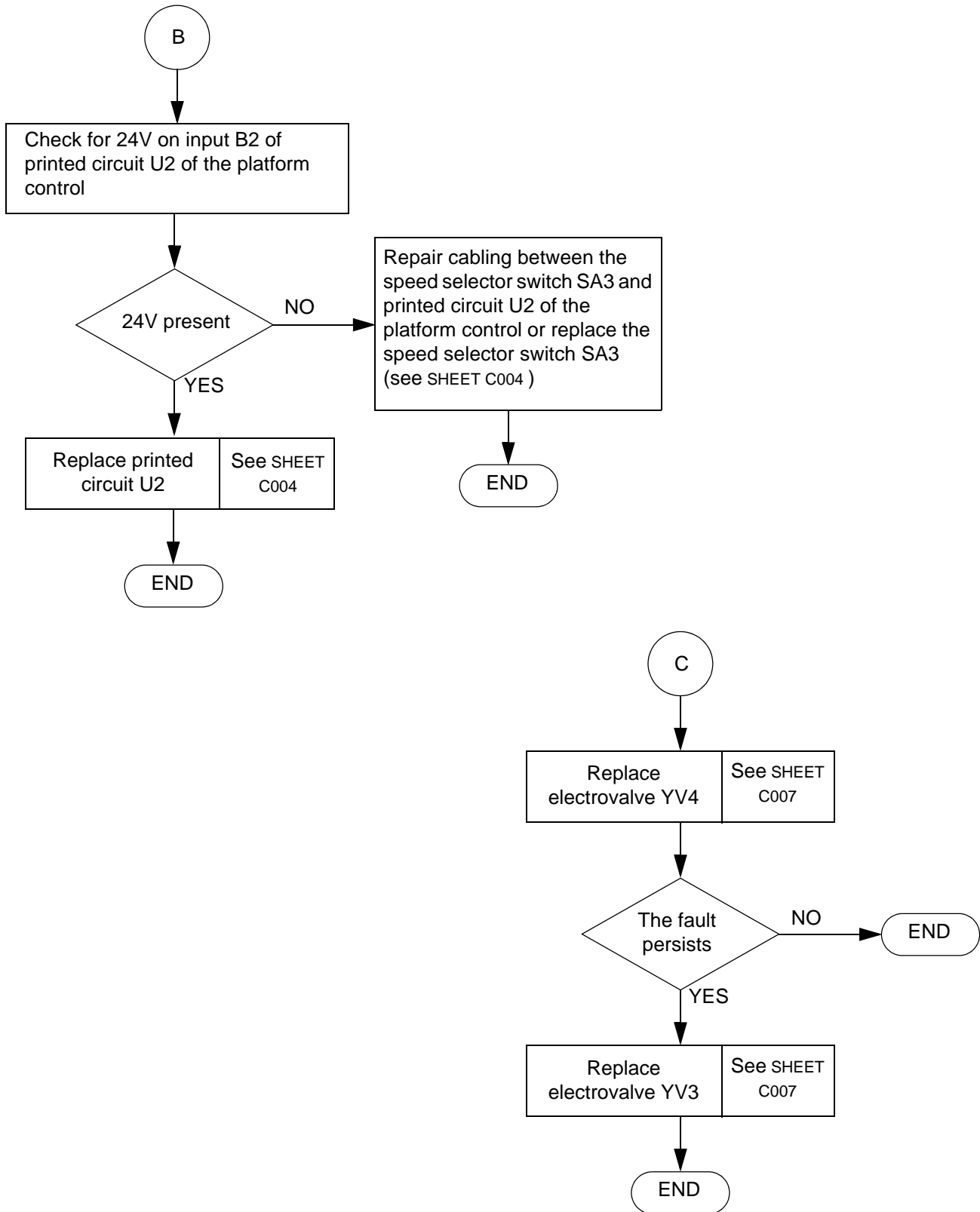

SHEET DP012	FAILURE DETECTION FLOW CHART	Sheet 1/2
	ONLY MICRO-SPEED IS AVAILABLE BELOW 1.5M OR 4FT92IN	

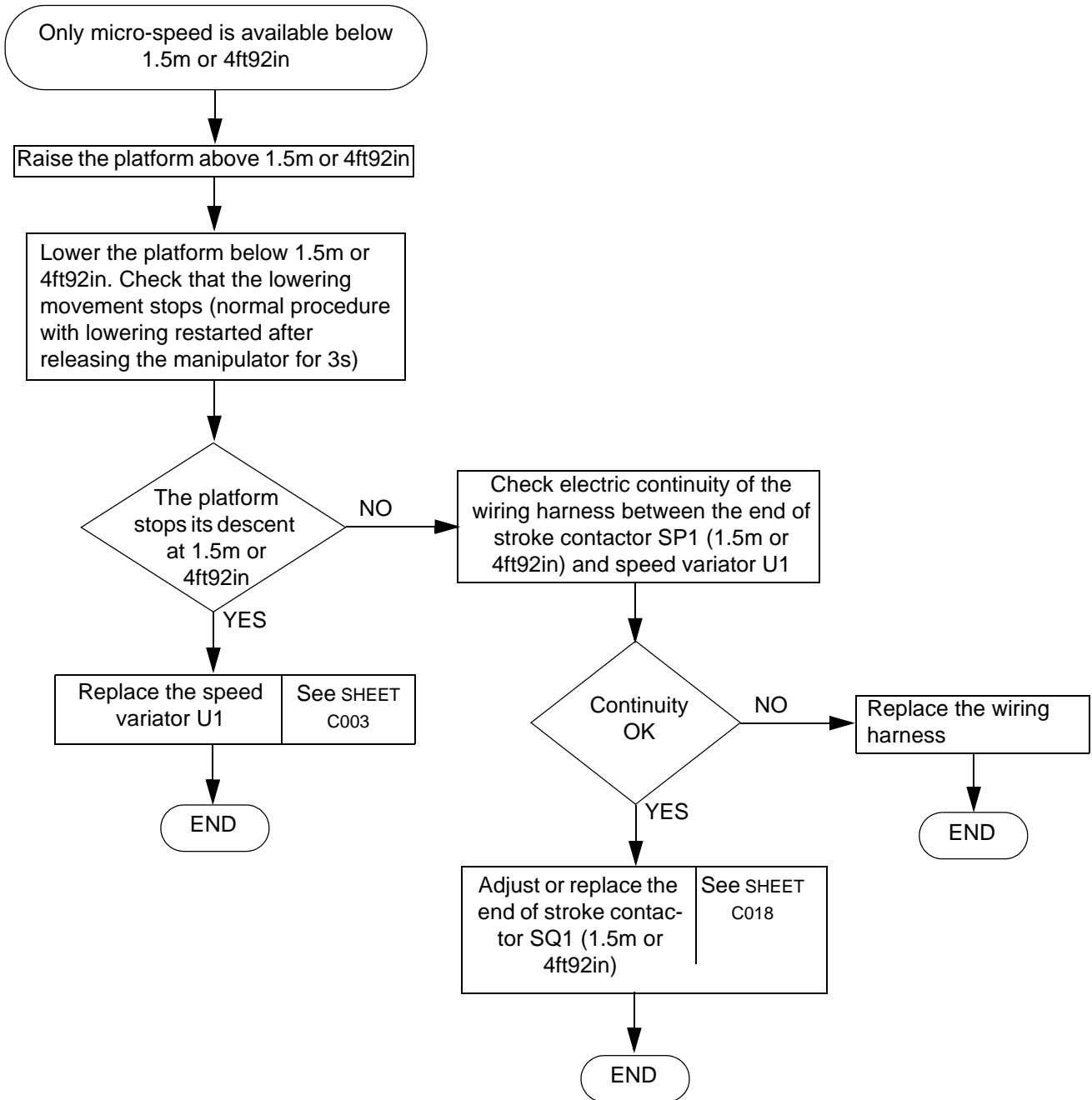

SHEET DP012	FAILURE DETECTION FLOW CHART	Sheet 2/2
	ONLY MICRO-SPEED IS AVAILABLE BELOW 1.5M OR 4FT92IN	

SHEET DP013	FAILURE DETECTION FLOW CHART	Sheet 1/2
	THE POTHOLE SYSTEM IS NOT EXTENDED WHEN THE PLATFORM IS LIFTED	

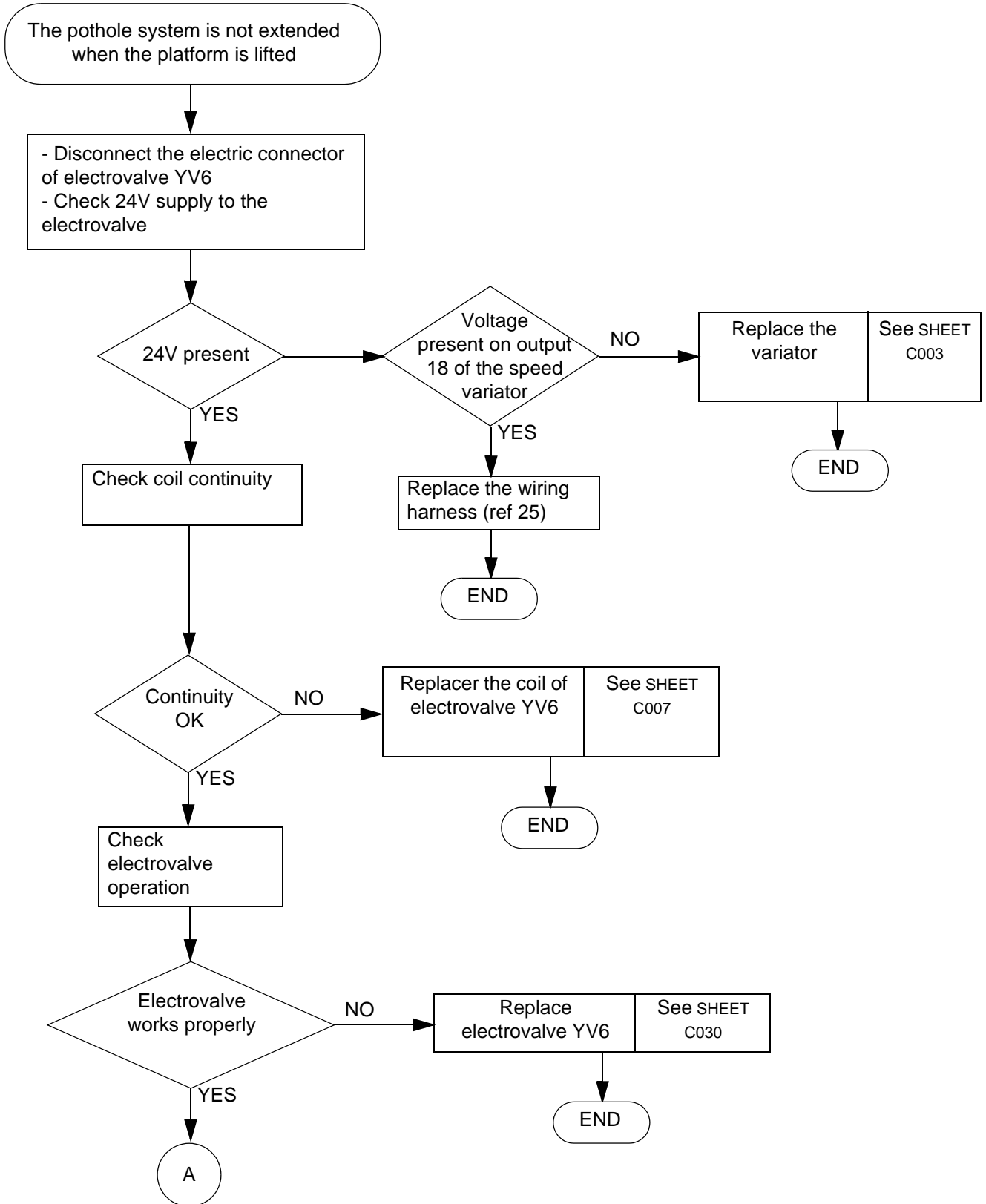

SHEET DP013	FAILURE DETECTION FLOW CHART	Sheet 2/2
	THE POTHOLE SYSTEM IS NOT EXTENDED WHEN THE PLATFORM IS LIFTED	

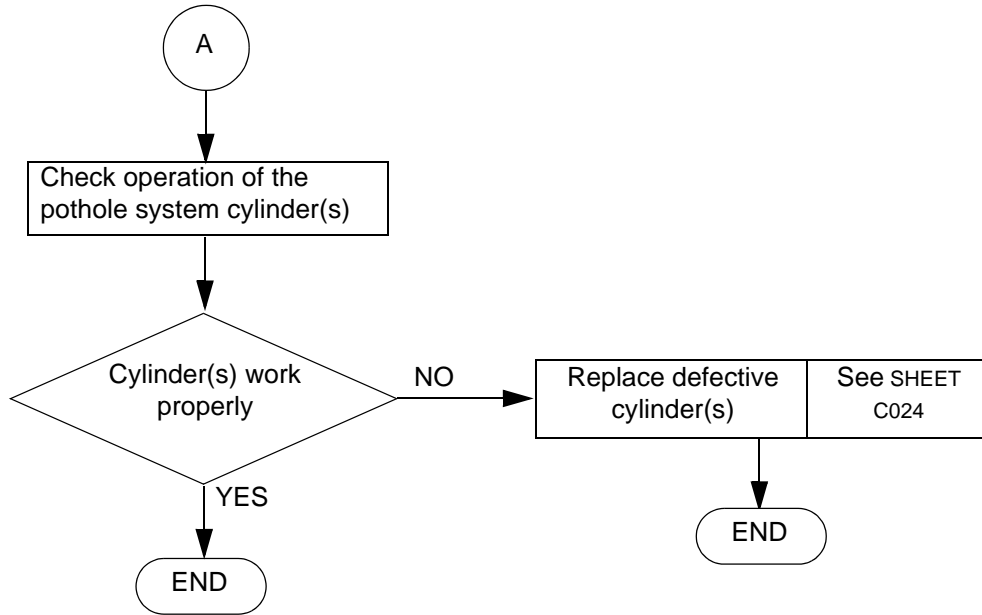

SHEET DP014	FAILURE DETECTION FLOW CHART	Sheet 1/4
	NO MOVEMENT FROM THE PLATFORM CONTROL PANEL	

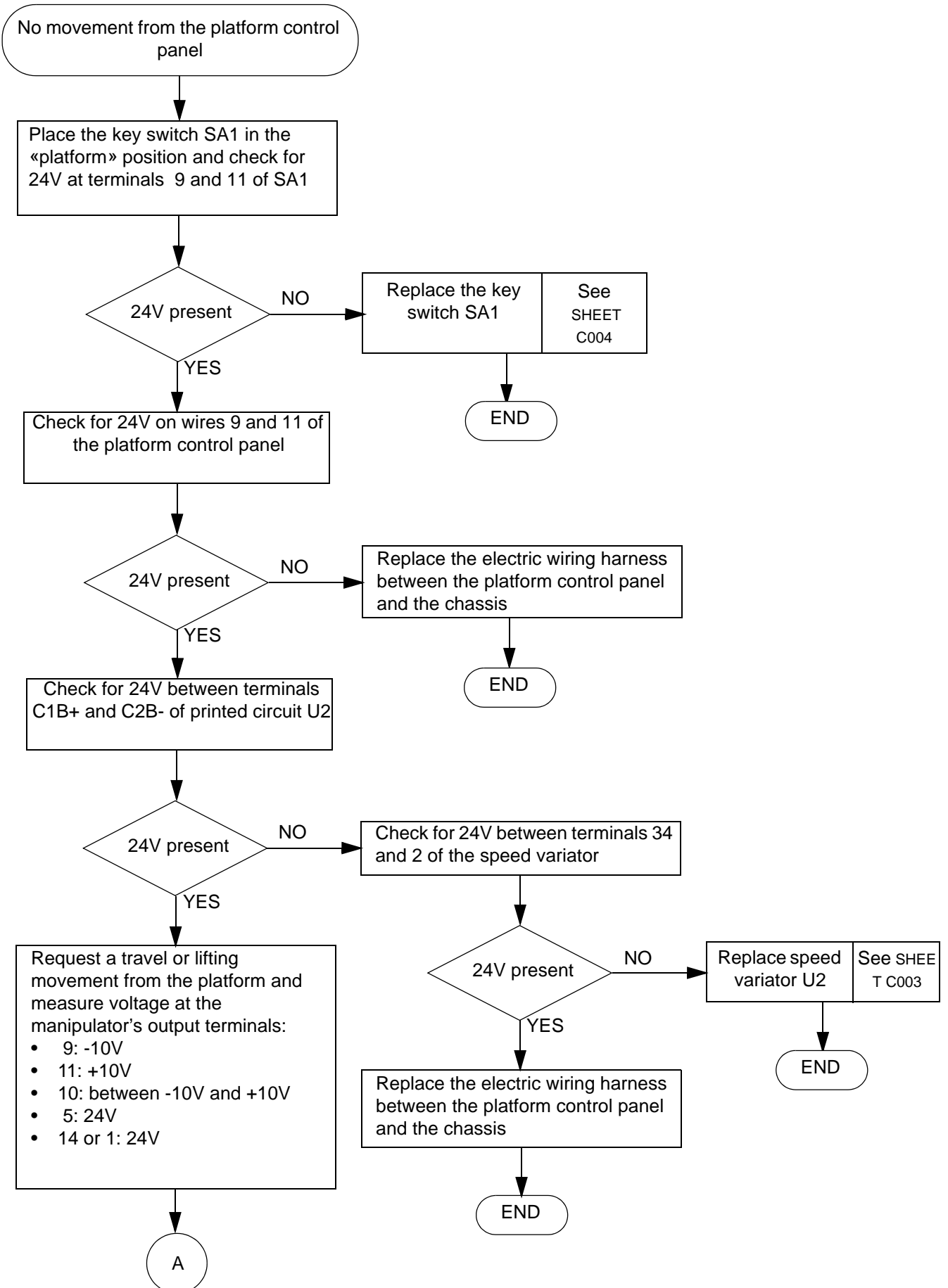

SHEET DP014	FAILURE DETECTION FLOW CHART	Sheet 2/4
	NO MOVEMENT FROM THE PLATFORM CONTROL PANEL	

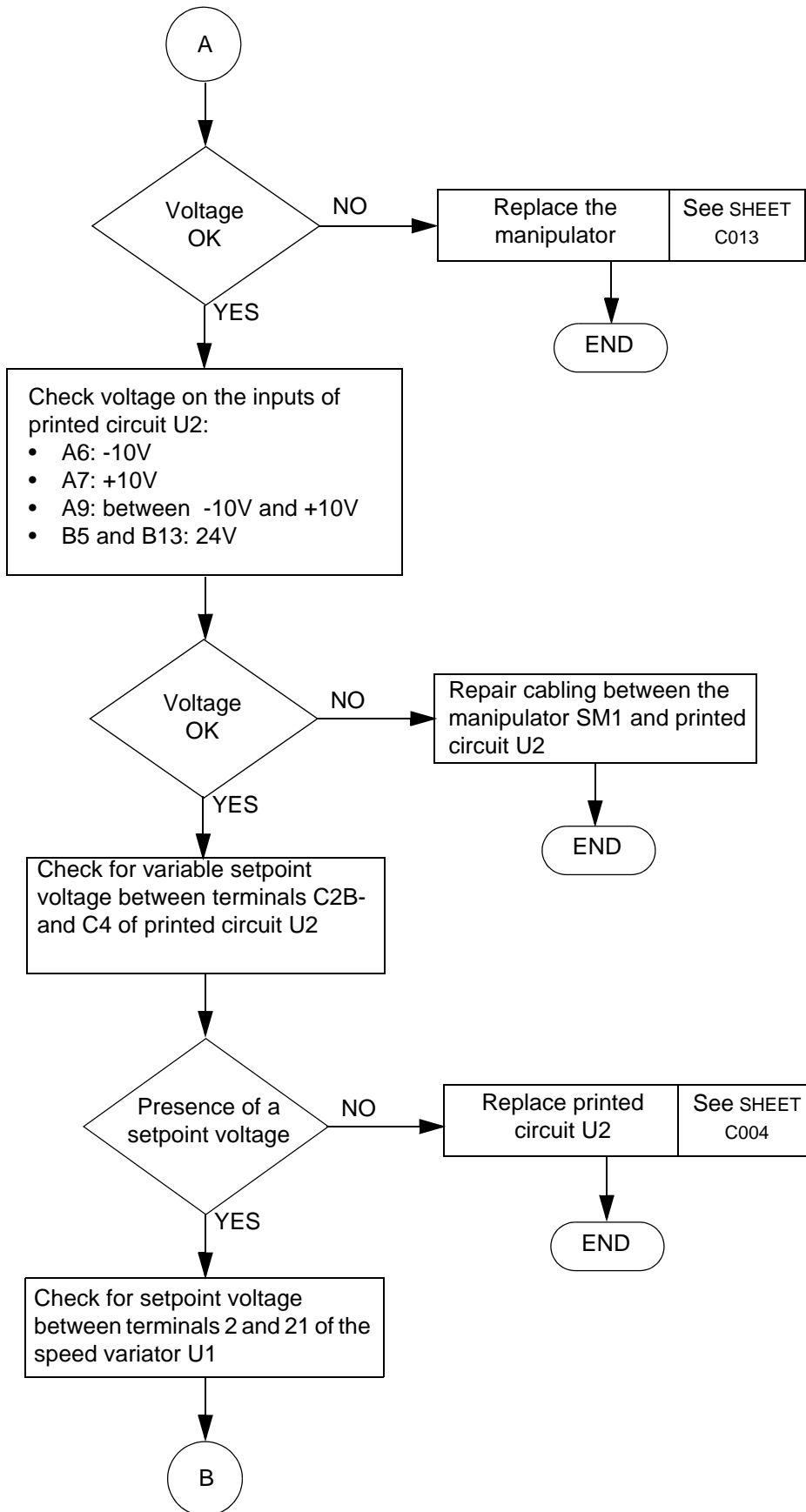

SHEET DP014	FAILURE DETECTION FLOW CHART	Sheet 3/4
	NO MOVEMENT FROM THE PLATFORM CONTROL PANEL	

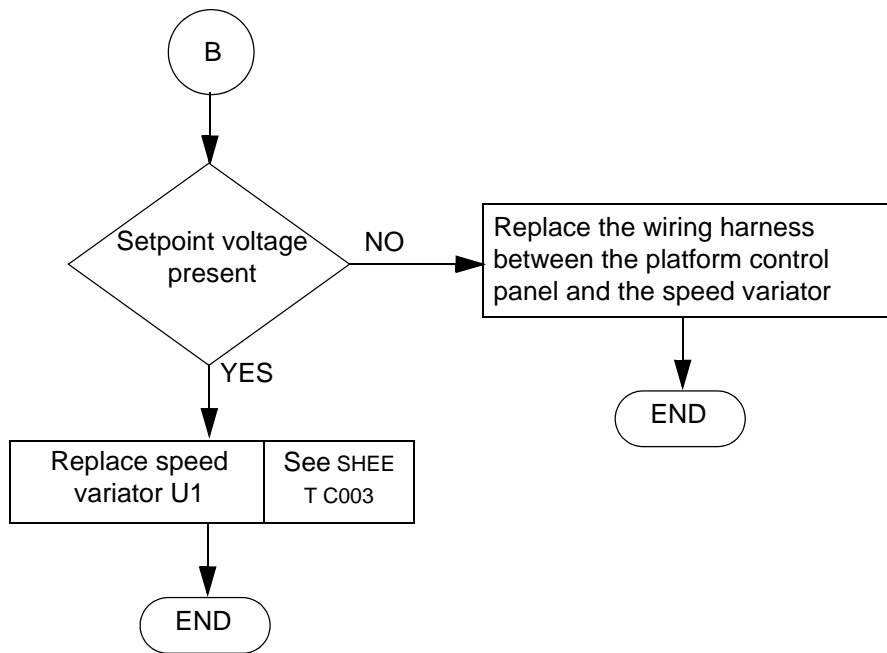

SHEET DP014	FAILURE DETECTION FLOW CHART	Sheet 4/4
	NO MOVEMENT FROM THE PLATFORM CONTROL PANEL	

SHEET DP061	FAILURE DETECTION FLOW CHART	Sheet 1/2
	PLATFORM (ABOVE 1.5M OR 4FT92IN) DESCENT IS SLOW FROM THE PLATFORM OR CHASSIS CONTROL	

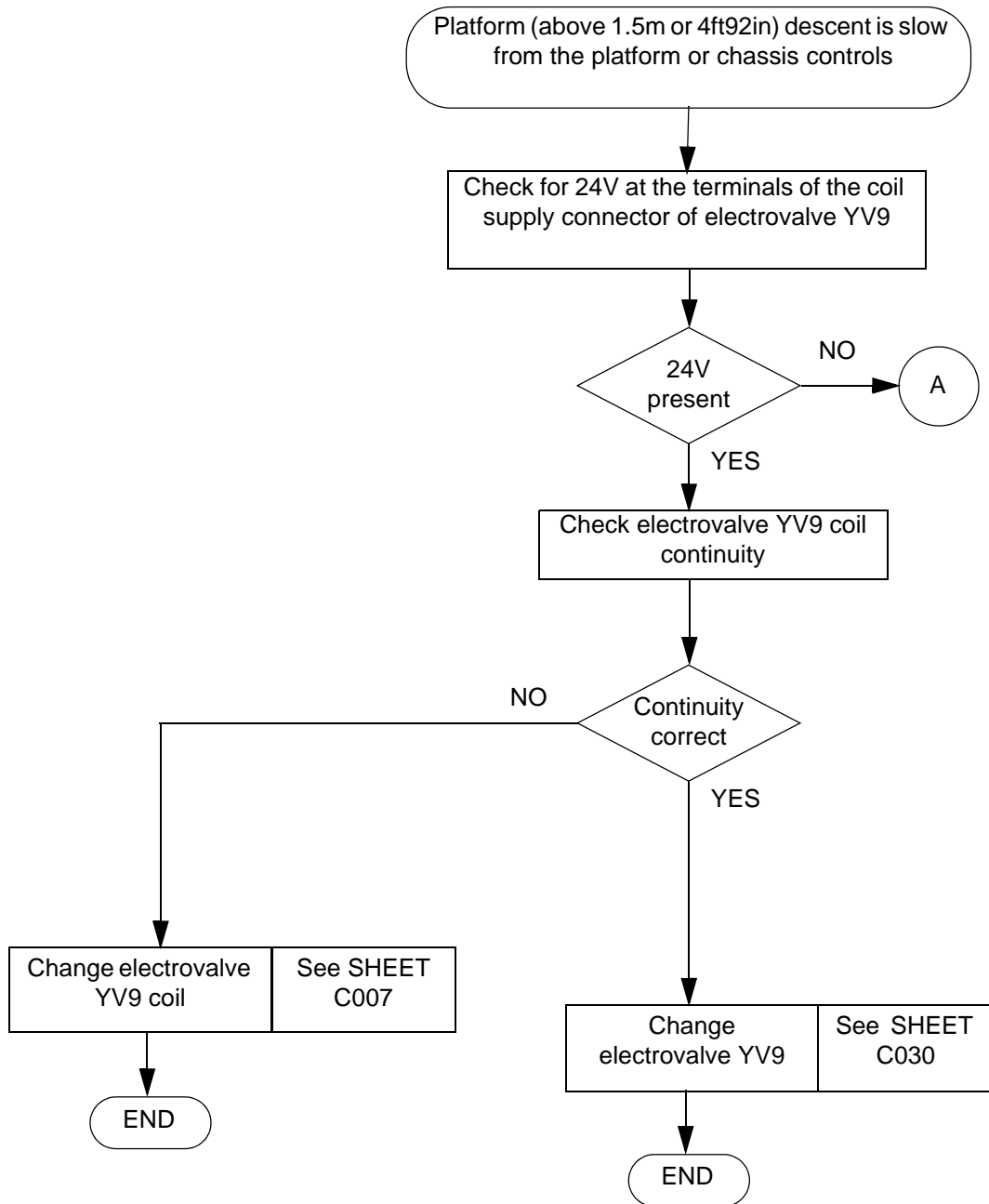

SHEET DP061	FAILURE DETECTION FLOW CHART	Sheet 2/2
	PLATFORM (ABOVE 1.5M OR 4FT92IN) DESCENT IS SLOW FROM THE PLATFORM OR CHASSIS CONTROL	

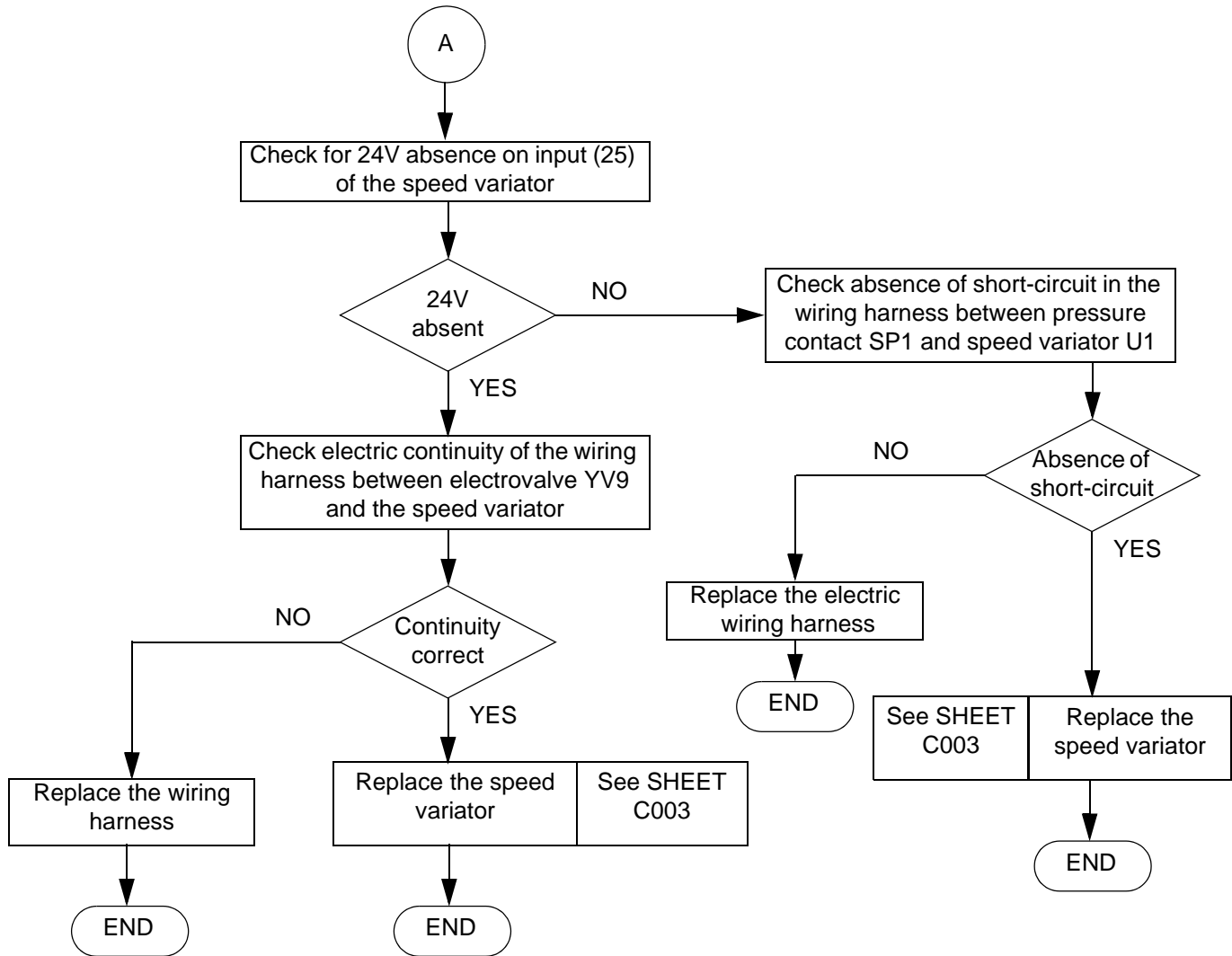

SHEET DP062	FAILURE DETECTION FLOW CHART	Sheet 1/4
	NO TRAVEL MOVEMENT IN BOTH DIRECTIONS FORWARD AND BACKWARD	

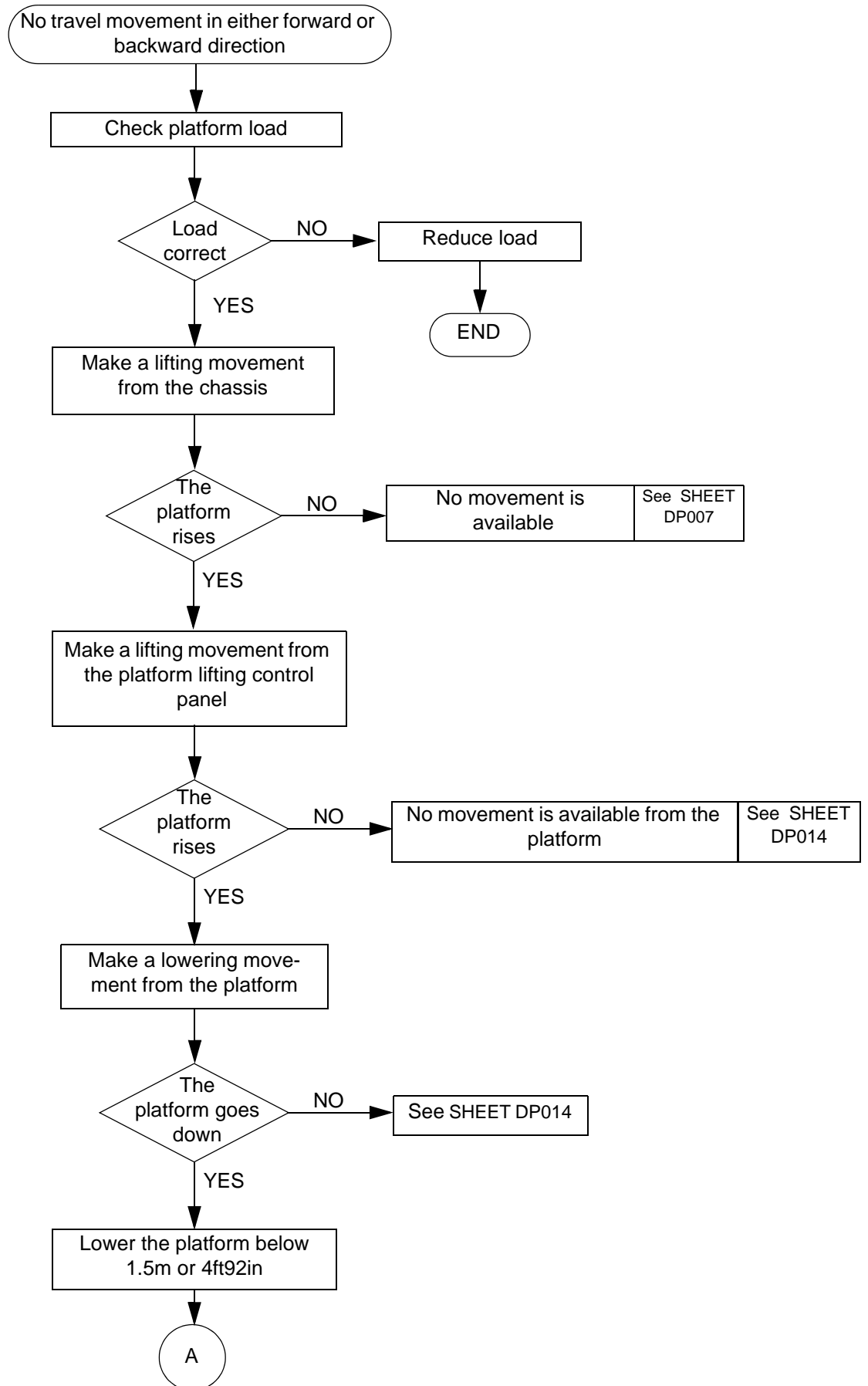

SHEET DP062	FAILURE DETECTION FLOW CHART	Sheet 2/4
	NO TRAVEL MOVEMENT IN BOTH DIRECTIONS FORWARD AND BACKWARD	

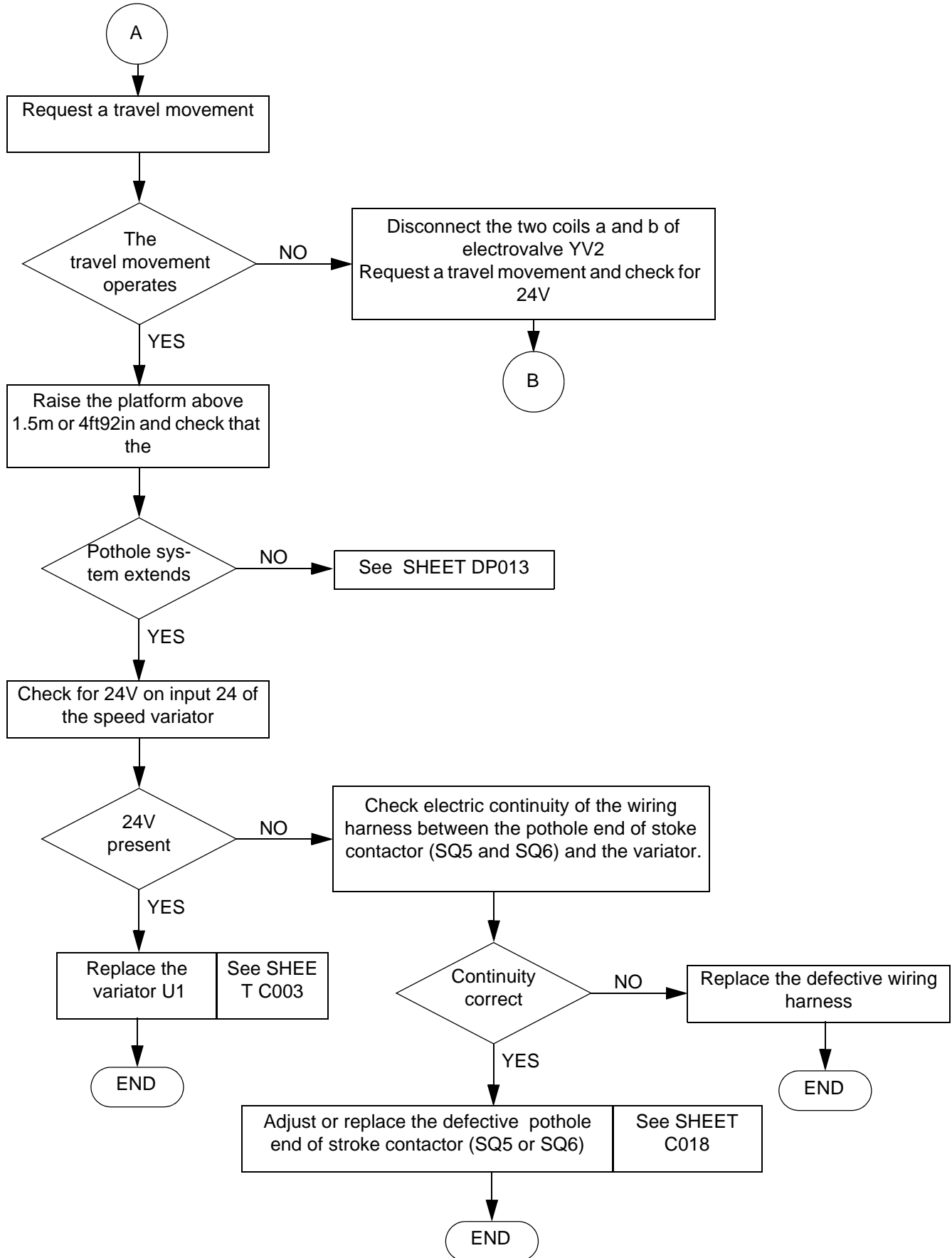

SHEET DP062	FAILURE DETECTION FLOW CHART	Sheet 3/4
	NO TRAVEL MOVEMENT IN BOTH DIRECTIONS FORWARD AND BACKWARD	

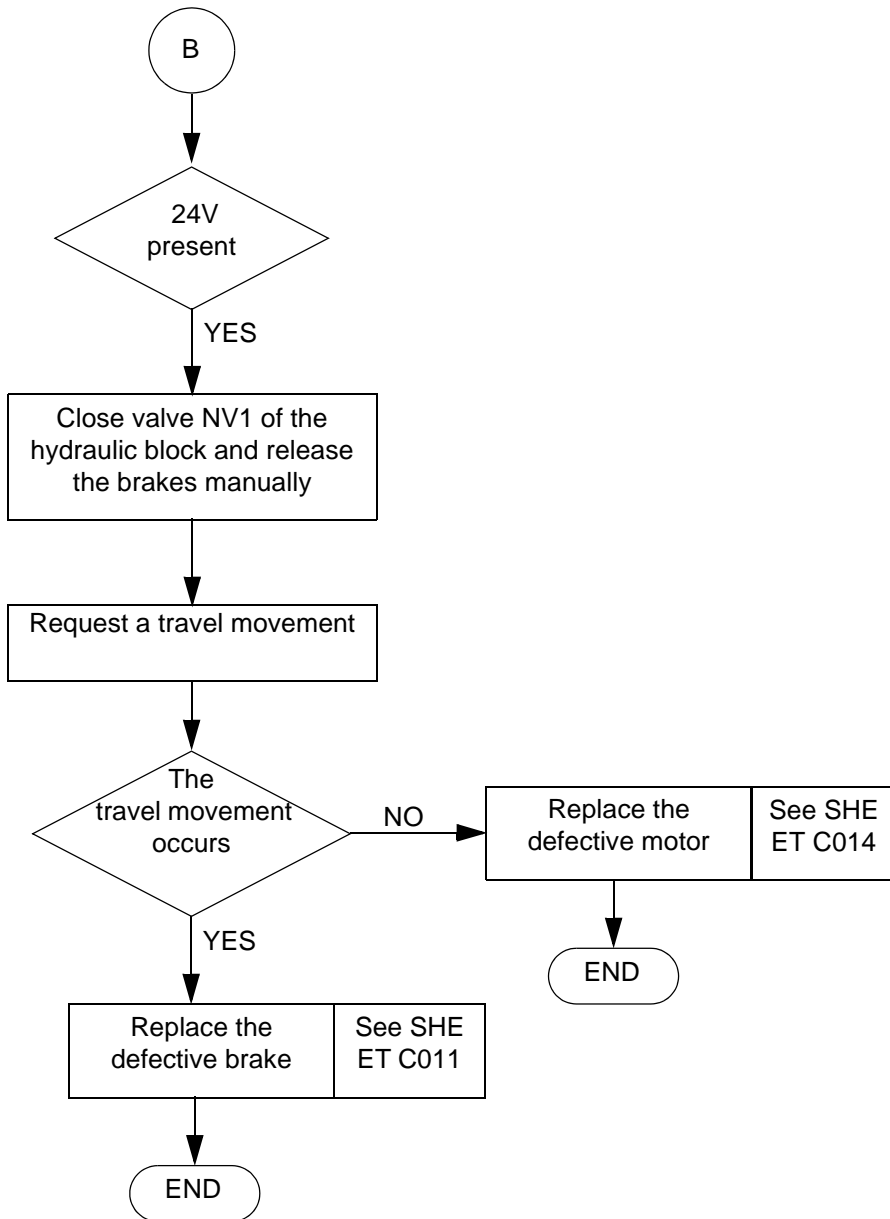

SHEET DP062	FAILURE DETECTION FLOW CHART	Sheet 4/4
	NO TRAVEL MOVEMENT IN BOTH DIRECTIONS FORWARD AND BACKWARD	

10 - CORRECTIVE MAINTENANCE PROCEDURES

List of corrective maintenance sheets:

<i>Sheet no.</i>	<i>Description</i>
SHEET C001	Replacing a lifting cylinder
SHEET C002	Adjusting a hydraulic block pressure limiter
SHEET C003	Replacing a speed variator
SHEET C004	Replacing a component on the platform control station
SHEET C005	Replacing a component on the chassis control station
SHEET C006	Replacing the tilt detector
SHEET C007	Replacing a coil
SHEET C008	Replacing the travel eletrovalve
SHEET C009	Replacing the hydraulic filter
SHEET C010	Replacing a hose
SHEET C011	Replacing a vacuum brake
SHEET C013	Replacing a manipulator
SHEET C014	Replacing a hydraulic travel motor
SHEET C015	Replacing the buzzer
SHEET C016	Replacing the distribution block
SHEET C017	Replacing the remote control system
SHEET C018	Replacing the end of stroke sensor
SHEET C019	Replacing the motor pump set
SHEET C020	Replacing a hydraulic block valve
SHEET C021	Replacing a wheel
SHEET C022	Replacing the brake release pull
SHEET C023	Replacing the steering cylinder
SHEET C024	Replacing a pothole cylinder
SHEET C025	Replacing the platform extension
SHEET C026	Replacing the platform
SHEET C027	Replacing the scissors (and pads)
SHEET C028	Replacing a scissor ring or axle
SHEET C029	Replacing the balancing valves
SHEET C030	Replacing a cartridge electrovalve
SHEET C031	Replacing the chassis emergency stop button
SHEET C032	Replacing the hydraulic pump
SHEET C033	Replacing and adjusting the pressure switch

SHEET C001	CORRECTIVE MAINTENANCE SHEET	Sheet 1/1
	REPLACING A LIFTING CYLINDER	

Caution!
 Ensure that oil temperature
 is not too high.

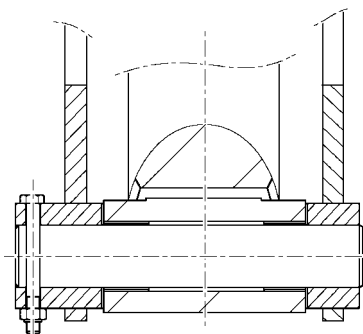
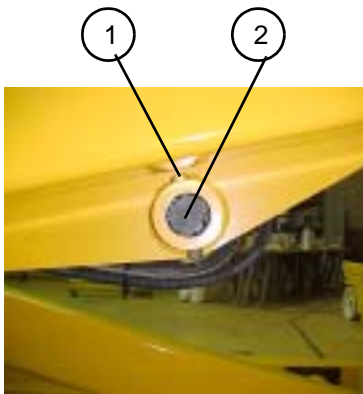

Fig. 1

1 - Preliminary operations

- Put the machine in the maintenance configuration (see § 7.2, page 51).
- Cut off the electric power supply (see § 7.3, page 52).

2 - Removing the cylinder

- Remove the cylinder remote control, if any (see SHEET C017).
- Mark and disconnect the cylinder pressure switch's electric connections.
- Mark and disconnect the cylinder's hydraulic hoses.
- Fit caps to the hoses.
- Put the cylinder into slings.
- Remove the two cylinder axle stop bolts (1), on the rod and body side.
- Remove the two axles (2) (also see figure 1) and remove the cylinder.

3 - Replacing the cylinder

- Put the new cylinder into place using slings.
- Put back the cylinder axle on the cylinder body side and secure using the axle stop bolt.

NB: Fit so that the screw is above the axle and the nut underneath (see figure 2).

- Reconnect the cylinder's hydraulic hoses according to the marks made when dismantling.
- Reconnect the pressure switches electric connections, according to the marks made when dismantling.
- Reconnect the cylinder's remote control, if any (see SHEET C017).
- Put the machine back into the operational configuration.
- Perform several lifting cycles to purge the hydraulic circuit.
- Check the oil level in the hydraulic oil tank.

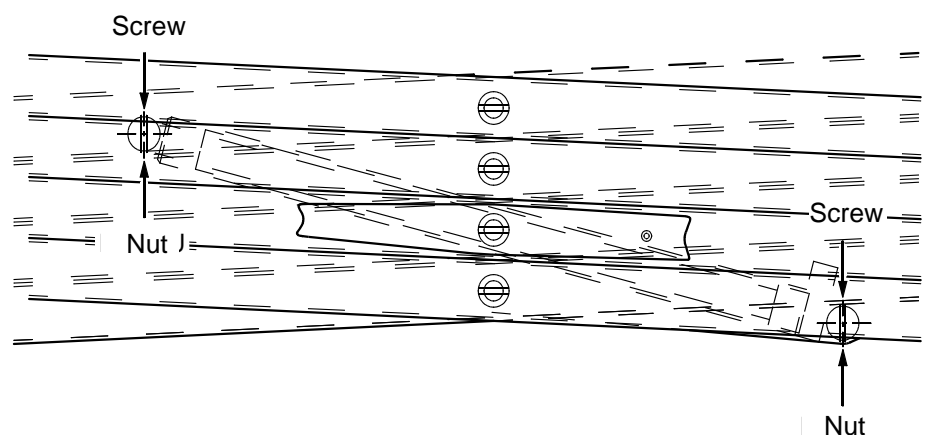
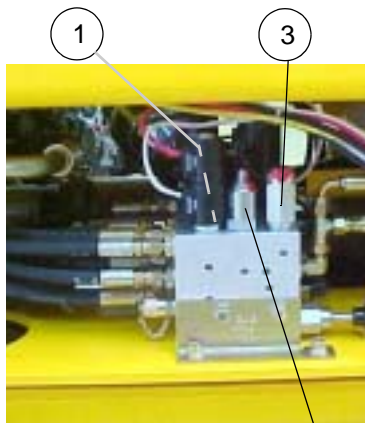

Fig. 2

	CORRECTIVE MAINTENANCE SHEET	

SHEET C002	CORRECTIVE MAINTENANCE SHEET	Sheet 1/2
	ADJUSTING A HYDRAULIC BLOCK PRESSURE LIMITER	

Caution!
 Ensure that oil temperature is not too high.



Compact

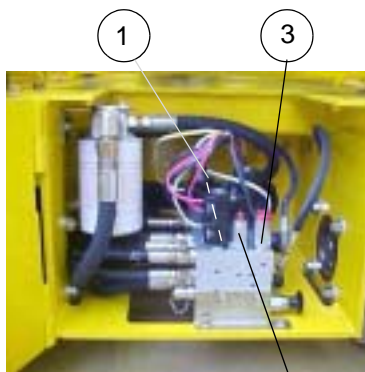

Optimum

1 - Adjusting the general pressure limiter (1)

- Put the machine in the low position.
- Cut off the electric power supply (see § 7.3, page 52).
- Unscrew the cap of the hydraulic pressure tap marked «MX» on the hydraulic block and connect a pressure gauge with sufficient range to measure overall pressure.
- Restore the electric power supply (see § 7.3, page 52).
- Bring the machine against a wall to block the travel movement.
- Request a travel movement and measure overall pressure on the pressure gauge.
- Adjust the hexagonal hollow head screw on the overall pressure limiter (1) so that movements are disabled at the pressure indicated in the table below.
- Put the machine in the maintenance configuration (see § 7.2, page 51).
- Cut off the electric power supply (see § 7.3, page 52).
- Unscrew the pressure gauge and put the cap back on the hydraulic pressure tap.
- Put the machine back in the operational configuration.
- Make several travel movements to check that the machine works properly.

2 - Adjusting the steering pressure limiter (2)

- Put the machine in the low configuration.
- Cut off the electric power supply (see § 7.3, page 52).
- Unscrew the cap of the hydraulic pressure tap marked «MX» on the hydraulic block and connect a pressure gauge with sufficient range to measure the steering pressure.
- Restore the electric power supply (see § 7.3, page 52).
- Activate the steering command as far as possible to the right or left.
- Maintain the steering command and measure the steering pressure on the pressure gauge.

NB: *Steering is disabled after a certain period when at the maximum in one direction, and only the other direction is possible and can re-authorise steering in the initial direction. The steering pressure measurement time is therefore limited.*

- If necessary, adjust the hexagonal hollow head screw on the steering pressure limiter (2) to disable movement at the pressure indicated in the table below.
- Put the machine in the maintenance configuration (see § 7.2, page 51).
- Cut off the electric power supply (see § 7.3, page 52).
- Unscrew the pressure gauge and put the cap back on the hydraulic pressure tap.
- Put the machine back in the operational configuration.
- Make several steering movements to check that the machine works properly.

SHEET C002	CORRECTIVE MAINTENANCE SHEET	Sheet 2/2
	ADJUSTING A HYDRAULIC BLOCK PRESSURE LIMITER	

3 - Adjusting the lifting pressure limiter (3)

- Put the platform in the low configuration.
- Unscrew the lifting pressure limiter adjusting screw (3).
- Place a load corresponding to nominal load + 10% in the platform (see table below).
- Lift the platform and tighten the pressure limiter adjustment screw until movements are disabled for this load.
- Place a load corresponding to nominal load in the platform (see table below).
- Check that the lifting movement is not disabled for this load.
- Put the machine back into the operational configuration.

4 - Load and pressure table

	Nominal load	Nominal load +10%	Overall hydraulic pressure	Steering pressure
H8SN 2032E	outdoor use: 120kg / 265 lb indoor use: 350kg / 770 lb	outdoor use: 132kg / 290 lb indoor use: 385kg / 850 lb	200 bars 3335 PSI	150 bars 2175 PSI
H8SW 2247E	outdoor use: 120kg / 265 lb indoor use: 450kg / 990 lb	outdoor use: 132kg / 290 lb indoor use: 495kg / 1090 lb	200 bars 3335 PSI	150 bars 2175 PSI
H10N 2632E	indoor use only: 230 kg / 500 lb	indoor use only: 253 kg / 520 lb	220 bars 3190 PSI	150 bars 2175 PSI
H10S 2747E	outdoor use: 120kg / 265 lb indoor use: 450kg / 990 lb	outdoor use: 132kg / 290 lb indoor use: 495kg / 1090 lb	220 bars 3190 PSI	150 bars 2175 PSI
H12SN 3347E	outdoor use: 120kg / 265 lb indoor use: 300kg / 660 lb	outdoor use: 132kg / 290 lb indoor use: 330kg / 730 lb	240 bars 3480 PSI	150 bars 2175 PSI
Optimum 6 1530E	outdoor use: 115kg / 254 lb indoor use: 270kg / 595 lb	outdoor use: 126.5kg / 280 lb indoor use: 297kg / 655 lb	230 bars 3335 PSI	100 bars 1450 PSI
Optimum 8 1930E	indoor use only: 230kg / 500 lb	indoor use only: 253kg / 520 lb	230 bars 3335 PSI	100 bars 1450 PSI

(tolerance: + or - 10%)

SHEET C003	CORRECTIVE MAINTENANCE SHEET	Sheet 1/2
	REPLACING THE SPEED VARIATOR	

1 - Preliminary operations

- Put the machine in the low position.
- Cut off the electric power supply (see § 7.3, page 52).
- Disconnect the + and - terminals of the batteries to isolate the electric circuit.

2 - Removing the speed variator

- Disconnect the speed variator's electric connections.
- Remove the speed variator (1).

3 - Replacing the speed variator

- Put the speed variator back into place and secure with the fixing screws.
- Reconnect the speed variator's electric connections.
- Reconnect the + and - terminals of the batteries.
- Put the machine back in the operational configuration.



Compact



Optimum

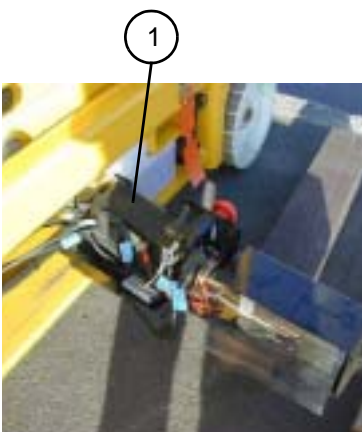

Compact

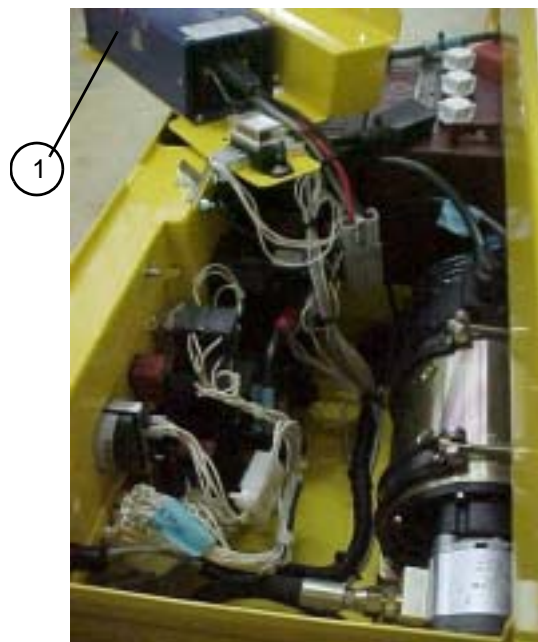

Optimum

SHEET C003	CORRECTIVE MAINTENANCE SHEET	Sheet 2/2
	REPLACING THE SPEED VARIATOR	

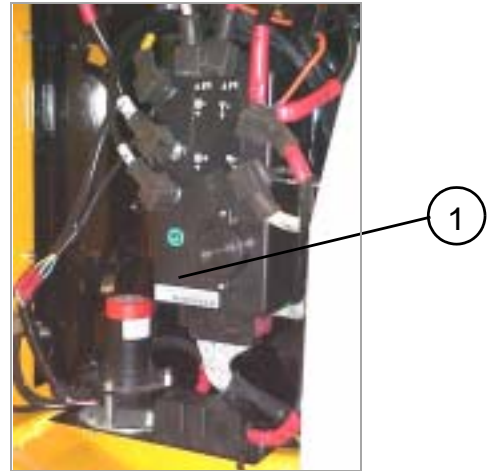

Star 22 J / Star 8



HA12IP / HA33JE - HA15IP / HA43JE



STAR 6 - STAR 13

SHEET C004	CORRECTIVE MAINTENANCE SHEET	Sheet 1/1
	REPLACING A COMPONENT ON THE PLATFORM CONTROL PANEL	

Caution!
Do not use the machine during maintenance operations.

1 - Preliminary operations

- Cut off the electric power supply (see § 7.3, page 50).

2 - Removing a component from the platform control panel

- Remove the closing plate (1) by unscrewing the four fixing screws.
- Mark and disconnect the electric connections of the component to be replaced.
- Remove the component.

3 - Replacing a component on the platform control panel

- Put a new component and seal into place on the front of the platform control panel.



Compact - Optimum

NB: If it is a lever switch, adjust the position of the fixing nut and counter nut so that the switch lever joint axle is on the same level as the seal, to ensure tightness.

- Reconnect the electric connections according to the marks made when dismantling.
- Fix the closing plate with the four fixing screws.
- Perform the function corresponding to the replaced component to check that it works properly.



Star 8 - HM10P (star 10)

	CORRECTIVE MAINTENANCE SHEET	

SHEET C005	CORRECTIVE MAINTENANCE SHEET	Sheet 1/1
	REPLACING A COMPONENT ON THE CHASSIS CONTROL PANEL	

Caution!
Do not use the machine during maintenance operations.

1 - Preliminary operations

- Put the machine in the maintenance configuration (see § 7.2, page 51).
- Cut off the electric power supply (see § 7.3, page 52).

2 - Removing a component from the chassis control panel (1)

- Remove the protective plate (2) from the chassis control panel.
- Mark and disconnect the electric connections of the component requiring replacement.
- Remove the component.

3 - Replacing a component in the chassis control panel

- Put the new component and seal on the front of the chassis control panel.



1

Compact

NB: *If it is a lever switch, adjust the position of the fixing nut and counter nut so that the switch lever joint axle is on the same level as the seal, to ensure tightness.*

- Reconnect the electric connections according to the marks made when dismantling.
- Put back the chassis control panel protective plate.



1

Optimum



2

4 - Test

- Put the machine back into the operational configuration.
- Perform the function corresponding to the replaced component to check that it works properly.

	CORRECTIVE MAINTENANCE SHEET	

SHEET C006	CORRECTIVE MAINTENANCE SHEET	Sheet 1/1
	REPLACING THE TILT DETECTOR	

Caution!
Do not use the machine during maintenance operations.



1 - Preliminary operations

- Place the platform on a flat, level floor with no slope.
- Put the machine in the maintenance configuration (see § 7.2, page 51).
- Cut off the electric power supply (see § 7.3, page 52).

2 - Removing the tilt detector

- Mark and disconnect the tilt detector's electric connections
- Remove the tilt detector by unscrewing the three fixing bolts.

3 - Replacing the tilt detector

- Put a new tilt detector into place and secure with the three fixing bolts.
- Reconnect the electric connections, according to the marks made when dismantling.
- Place a spirit level on the top of the tilt detector and adjust the fixing screws to align the tilt detector.

NB: *A spirit level is built into certain tilt detectors.*

- Put the machine back into the operational configuration.

4 - Operating test of the tilt detector

- Lift the platform to a height of 2m.
- Tilt the tilt detector (see photo) and check that a signal is given (the signal should be audible from the platform).

	CORRECTIVE MAINTENANCE SHEET	

SHEET C007	CORRECTIVE MAINTENANCE SHEET	Sheet 1/1
	REPLACING A COIL	

1 - Preliminary operations

- Put the machine in the maintenance configuration (see § 7.2, page 51).
- Cut off the electric power supply (see § 7.3, page 52).

2 - Removing a coil

- Unscrew the two fixing screws (1) from the fixing lug and take out the hydraulic block.
- Disconnect the relevant coil's electric connector (2).
- Unscrew the nut (3) or (4) and remove the coil (5).

3 - Replacing a coil

- Put a new coil (5) into place and secure with the nut (3) or (4).
- Reconnect the electric connector (2) on the coil.
- Put the hydraulic block back into place and secure with the screws (1) equipped with new flat and toothed washers.
- Put the machine back into the operational configuration.

Check that the coil works properly by performing the movement corresponding to the replaced coil.

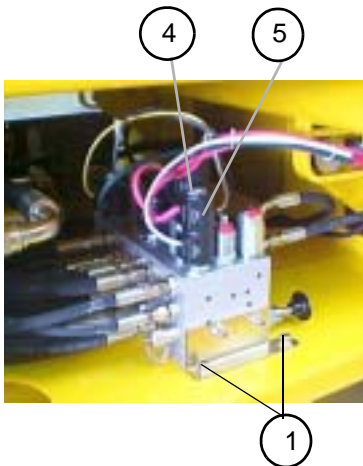

Compact

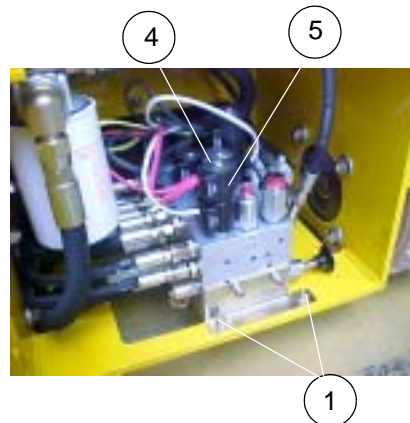
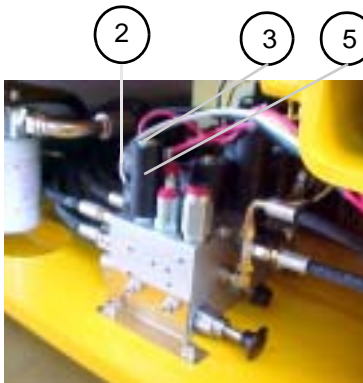

Optimum

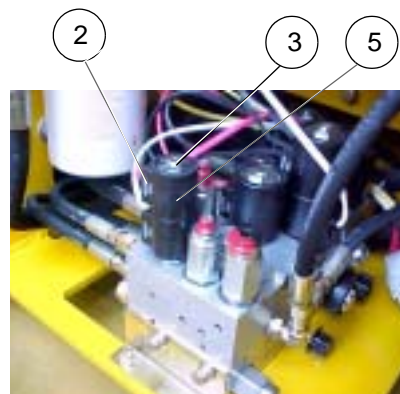

	CORRECTIVE MAINTENANCE SHEET	

SHEET C008	CORRECTIVE MAINTENANCE SHEET	Sheet 1/1
	REPLACING THE TRAVEL ELECTROVALVE	

Caution!
Ensure that oil temperature is not too high.

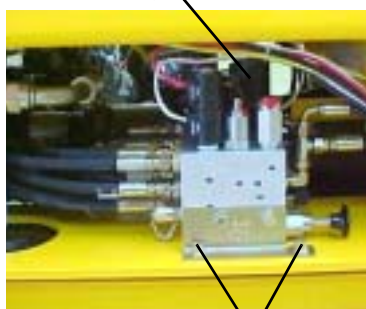

Compact

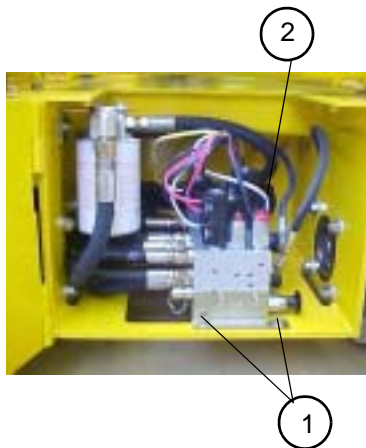

Optimum

1 - Preliminary operations

- Put the machine in the maintenance configuration (see § 7.2, page 51).
- Cut off the electric power supply (see § 7.3, page 52).

2 - Removing the travel electrovalve

- Unscrew the two screws (1) on the fixing lug and take out the hydraulic block.
- Mark and disconnect the coil's electric connections.
- Remove the coils of the electrovalve (2) and remove it.

3 - Replacing the travel electrovalve

- Put a new electrovalve equipped with its seal into place.
- Reconnect the electric connections on the coils.
- Put back the hydraulic block and secure using the screws (1) equipped with new flat and toothed washers.
- Put the machine back into the operational configuration.
- Make several travel movements to check that it works properly.

	CORRECTIVE MAINTENANCE SHEET	

SHEET C009	CORRECTIVE MAINTENANCE SHEET	Sheet 1/1
	REPLACING THE HYDRAULIC FILTER	

Caution!
Ensure that oil temperature is not too high.

1 - Preliminary operations

- Put the machine in the maintenance configuration (see § 7.2, page 51).
- Cut off the electric power supply (see § 7.3, page 52).

2 - Removing the hydraulic filter

- Disconnect the two hydraulic filter hoses.
- Fit caps on the hoses.
- Unscrew the fixing screws (1) and remove the hydraulic filter.
- Remove the two hydraulic filter connections (2).

3 - Replacing the hydraulic filter

- Put the two connections (2) on a new hydraulic filter.
- Put the equipped hydraulic filter into place, respecting the oil flow direction; secure with the fixing screws.
- Reconnect the hydraulic hoses.
- Put the machine back into the operational configuration.
- Perform several lifting cycles to purge the hydraulic circuit.



Compact



Optimum

	CORRECTIVE MAINTENANCE SHEET	

SHEET C010	CORRECTIVE MAINTENANCE SHEET	Sheet 1/1
	REPLACING A HOSE	

Caution!
**Ensure that oil temperature
is not too high.**

1 - Preliminary operations

- Put the machine in the maintenance configuration (see corresponding paragraph).
- Cut off the electric power supply (see corresponding paragraph).

2 - Removing a hose

- Disconnect the hose from the equipment it connects.

NB: Unscrew the hose slowly to allow residual hydraulic pressure to dissipate.

- Fit caps to the equipment holes to protect them.

3 - Replacing a hose

- Reconnect a new hydraulic hose.
 - Put the machine back into the operational configuration.
 - Make several movements using the replaced hose to purge the hydraulic circuit.
 - Check the oil level in the hydraulic oil tank.
-

C010	CORRECTIVE MAINTENANCE SHEET	Sheet 2/2

SHEET C011	CORRECTIVE MAINTENANCE SHEET	Sheet 1/1
	REPLACING A VACUUM BRAKE	

Caution!
*Ensure that oil temperature
 is not too high.*

1 - Preliminary operations

- Put the machine in the low configuration.
- Cut off the electric power supply (see § 7.3, page 52).
- Raise the machine using a jack or hoist.

2 - Removing a vacuum brake (see figure 1)

- Remove the pin (3) and nut (4) fixing the wheel and remove the wheel (1).
- Place a wedge under the vacuum brake.
- Disconnect the vacuum brake's hose.
- Fit a cap to the hose.
- Remove the vacuum brake (2) by removing its fixing bolts (5) (6) (7).

3 - Replacing a vacuum brake

- Put the new vacuum brake (2) into place.
- Secure the vacuum brake using the fixing bolts equipped with new elastic washers (5).
- Reconnect the hydraulic hose.
- Put the wheel (1) into place and secure using the fixing nut and pin.
- Put the machine back into the operational configuration.
- Perform several brake/release operations to purge the hydraulic circuit.
- Check the oil level in the hydraulic oil tank.

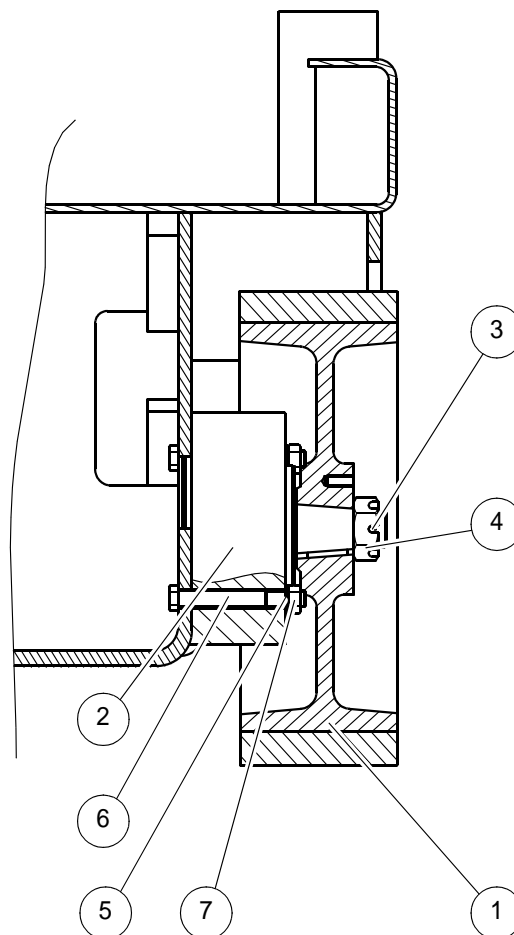

Wheel nut tightening torque :
 25 N/m

To fix the pin, the slot must
 be in front of an hole : at this
 time we can screw until
 30 N/m.

Fig. 1

	CORRECTIVE MAINTENANCE SHEET	

SHEET C013	CORRECTIVE MAINTENANCE SHEET	Sheet 1/1
	REPLACING THE MANIPULATOR	

Caution!
Do not use the machine during maintenance operations.



1 - Preliminary operations

- Put the machine in the maintenance configuration (see § 7.2, page 51).
- Cut off the electric power supply (see § 7.3, page 52).

2 - Removing the manipulator (2)

- Remove the closing plate (1) by removing the four fixing screws.
- Mark and disconnect the manipulator's electric connections.
- Remove the manipulator by removing its fixing screws.

3 - Replacing the manipulator

- Fix a manipulator, equipped with new seals, to the platform control panel.
- Reconnect the electric connections, according to the marks made when dismantling.
- Put the closing plate back into place and secure with the four fixing screws.
- Put the machine back into the operational configuration.
- Make several up and down movements from the platform to check that the manipulator works properly.

	CORRECTIVE MAINTENANCE SHEET	

SHEET C014	CORRECTIVE MAINTENANCE SHEET	Sheet 1/1
	REPLACING A HYDRAULIC TRAVEL MOTOR	

Caution!
*Ensure that oil temperature
 is not too high.*

1 - Preliminary operations

- Put the machine in the low configuration (see § 7.2, page 51).
- Cut off the electric power supply (see § 7.3, page 52).
- Raise the machine using a jack or hoist.

2 - Removing a hydraulic travel motor (see figure 1)

- Remove the pin (2) and nut (1) fixing the wheel and remove the wheel (7).
- Mark and disconnect the two hydraulic motor hoses.
- Fit caps to the hoses.
- Place a wedge under the hydraulic motor.
- Remove the hydraulic motor (4) by removing its four fixing bolts (3) (5) (6).

3 - Replacing a hydraulic travel motor

- Put a new hydraulic motor into place.
- Secure the hydraulic motor using the four fixing bolts, equipped with new elastic washers.
- Reconnect the hydraulic hoses according to the marks made when dismantling.
- Put the wheel back and secure with the fixing nut and pin.
- Put the machine back into the operational configuration.
- Make several travel movements to purge the hydraulic circuit.
- Check the oil level in the hydraulic oil tank.

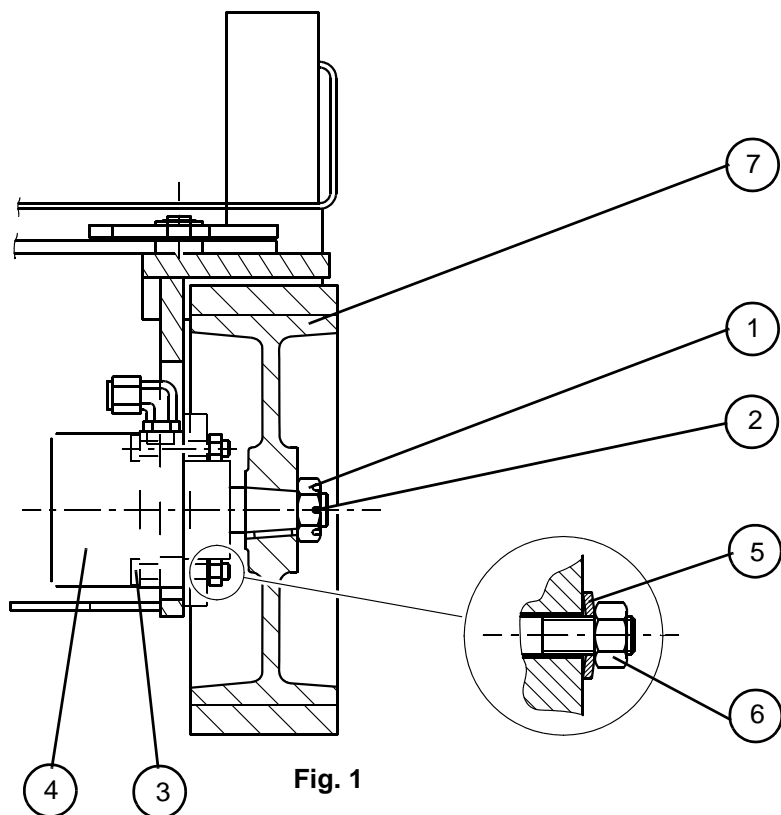

Fig. 1

Wheel nut tightening torque : 25 N/m / 18 lbf.ft

To fix the pin, the slot must be in front of an hole : at this time we can screw until 30 N/m / 22 lbf.ft

	CORRECTIVE MAINTENANCE SHEET	

SHEET C015	CORRECTIVE MAINTENANCE SHEET	Sheet 1/1
	REPLACING THE BUZZER	

Caution!
Do not use the machine during maintenance operations.

1 - Preliminary operations

- Cut off the electric power supply (see § 7.3, page 52).

2 - Remove the buzzer

- Mark and disconnect the buzzer's electric connections (1).
- Remove the buzzer by unscrewing the fixing bolt.

3 - Replacing the buzzer

- Put the new buzzer into place and secure with the fixing bolt.
- Reconnect the electric connections according to the marks made when dismantling.

4 - Test

- Put the machine back into the operational configuration.
- Check that the buzzer gives a signal below 1.5 metres (or 4ft92in) during lowering.



1

Compact



1

Optimum

	CORRECTIVE MAINTENANCE SHEET	

SHEET C016	CORRECTIVE MAINTENANCE SHEET	Sheet 1/1
	REPLACING THE DISTRIBUTION BLOCK	

1 - Preliminary operations

- Put the machine in the maintenance configuration (see § 7.2, page 51).
- Cut off the electric power supply (see § 7.3, page 52).

Caution!
Ensure that oil temperature is not too high.

2 - Removing the distribution block

- Remove the fixing lug (1) securing the distribution block to the chassis, and take out the distribution block (2) to access its components.
- Mark and disconnect the distribution block's electric connections.
- Mark and disconnect the distribution block's hydraulic hoses.

NB: Unscrew the hoses slowly to allow the residual hydraulic pressure to dissipate.

- Fit caps to the hoses.
- Remove the distribution block.

2 - Replacing the distribution block

- Put the new distribution block into place.
- Reconnect the hydraulic hoses according to the marks made when dismantling.
- Reconnect the distribution block's electric connections, according to the marks made when dismantling.
- Secure the distribution block to the chassis using the fixing lug, screws and washers.
- Put the machine back into the operational configuration.
- Perform several lifting, steering and travel cycles to purge the hydraulic circuit.
- Check the oil level in the hydraulic oil tank.

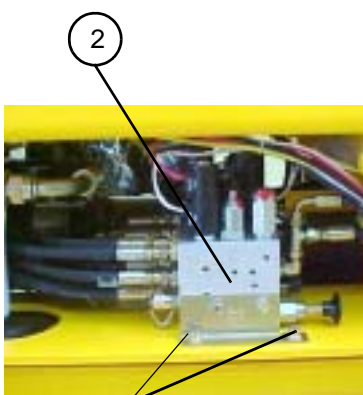

1
Compact

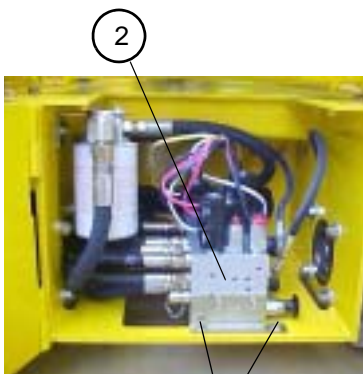

1
Optimum

	CORRECTIVE MAINTENANCE SHEET	

SHEET C017	CORRECTIVE MAINTENANCE SHEET	Sheet 1/2
	REPLACING THE REMOTE CONTROL	

1 - Preliminary operations

- Put the machine in the maintenance configuration (see § 7.2, page 51).
- Cut off the electric power supply (see § 7.3, page 52).

2 - Removing the remote control

- Remove the protective plate (4) of the chassis control station (for **Compact** machines).
- Release the manual control cable (2) of the covered distributing valve on the lifting cylinder.
- Unscrew the plate sheath stop (3) supporting the cable.
- Mark the cable route in the scissor ducts and remove the cable from the ducts.
- Unscrew the blocking nut of the emergency pull (1) and remove the pull and cable assembly.



4

Compact

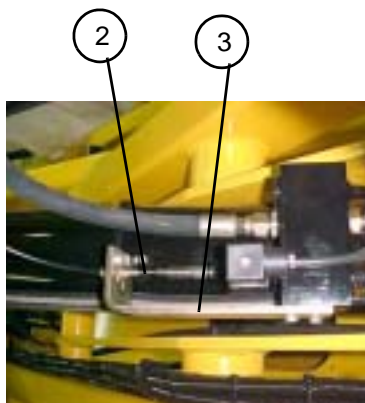

1

Compact



1

Optimum

3 - Replacing the remote control

- Put the remote control cable back into place in the scissor ducts, according to the route marked when dismantling.
- Put the emergency pull (1) in place on the chassis and secure with the blocking nut.
- Screw the sheath stop onto the cable support plate (3) at the distributing valve level.
- Secure the cable to the distributing valve manual control.
- Put the chassis control panel protective plate (4) back into place (for **Compact** machines).
- Put the machine back into the operational configuration.
- Raise the platform to a height of 2m (or 6ft56in) and activate the emergency pull to check that it works properly.

	CORRECTIVE MAINTENANCE SHEET	Sheet 2/2

SHEET C018	CORRECTIVE MAINTENANCE SHEET	Sheet 1/1
	REPLACING AN END OF STROKE CONTACTOR	

Caution!
Do not use the machine during maintenance operations.



1 - Preliminary operations

- Put the machine in the maintenance configuration (see § 7.2, page 51).
- Cut off the electric power supply (see § 7.3, page 52).

2 - Removing an end of stroke contactor

- Mark the position of the end of stroke contactor (1) and its lever (2).
- Remove the end of stroke contactor.
- Open the end of stroke contactor, mark and disconnect the electric connections.

3 - Replacing an end of stroke contactor

- Open the new end of stroke contactor, reconnect the electric connections and close the end of stroke contactor.
- Move the end of stroke contactor's lever (2) back to the position marked when dismantling.
- Put the end of stroke contactor into place in the position marked when dismantling and secure with bolts (3) without tightening.

4 - Test

- Put the machine into the operational configuration.
- Perform the movement, using the contactor concerned (see table) and check that it works properly.
- Adjust the contactor position if necessary and tighten the fixing bolts.

CONTACTOR	MOVEMENT TO BE MADE	CHECK
Lifting end of stroke (SQ3)	Lifting	Lifting disabled in the high position
Pothole end of stroke (SQ5 and SQ6)	Lifting	<ul style="list-style-type: none"> • Extension of the potholes when the platform reaches 1.5m. • Microspeed present
	<ul style="list-style-type: none"> • Disconnect YV6 • Lifting 	<ul style="list-style-type: none"> • Lifting impossible beyond 1.5m • Travel impossible beyond 1.5m
Tilt reset end of stroke (SQ1)	Lifting beyond 1.5m and lowering	Check that the lowering movement is correct with an interruption at 1.5m.
8m end of stroke switch (SQ4) (H12SN only)	Lifting beyond 8m	Travel impossible (microspeed disabled)

	CORRECTIVE MAINTENANCE SHEET	

SHEET C019	CORRECTIVE MAINTENANCE SHEET	Sheet 1/2
	REPLACING THE MOTOR PUMP SET	

1 - Preliminary operations

- Put the machine in the maintenance configuration (see § 7.2, page 51).
- Cut off the electric power supply (see § 7.3, page 52).

Caution!
Ensure that oil temperature is not too high.

NB: *Lift the platform using a gantry crane or fork-lift truck*

2 - Removing the motor pump set

- Remove the upper inspection flap (for **Compact** machines).
- Mark and disconnect the motor's electric connections (1).
- Mark and disconnect the hydraulic pump's hoses (3).
- Fit caps to the hoses.
- Remove the fixing collars (2) from the motor pump set and remove the motor pump set.
- Remove the hydraulic pump's suction and backflow flanges (4).

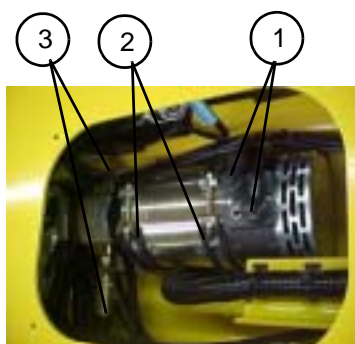

3 - Replacing the motor pump set

- Put the suction and backflow flanges equipped with new seals on a motor pump set.
- Put the motor pump set into place and secure with the collars.
- Reconnect the hydraulic hoses to the pump according to the marks made when dismantling.
- Reconnect the electric connections to the motor according to the marks made when dismantling.
- Close the inspection flap (for **Compact** machines).
- Put the machine back into the operational configuration.
- Perform several lifting cycles to purge the hydraulic circuit.
- Check the oil level in the hydraulic oil tank.



	CORRECTIVE MAINTENANCE SHEET	Sheet 2/2

SHEET C020	CORRECTIVE MAINTENANCE SHEET	Sheet 1/2
	REPLACING A HYDRAULIC BLOCK VALVE	

1 - Preliminary operations

- Put the machine in the maintenance configuration (see § 7.2, page 51).
- Cut off the electric power supply (see § 7.3, page 52).

Caution!
Ensure that oil temperature is not too high.

2 - Removing a valve from the hydraulic block

- Unscrew the fixing screws (3) and take out the hydraulic block (4) if necessary to make access easier.
- Open the valve concerned.
- Unscrew the base (2) of the valve (1) and remove from the hydraulic block.
- Fit a cap to the hydraulic block hole to protect it.

3 - Replacing a valve in the hydraulic block

- Screw a new valve onto the hydraulic block.
- Put the valve back into its initial state.
- Fix the hydraulic block on with the fixing screws (3).
- Put the machine back into the operational configuration.
- Make several travel movements to purge the hydraulic circuit.

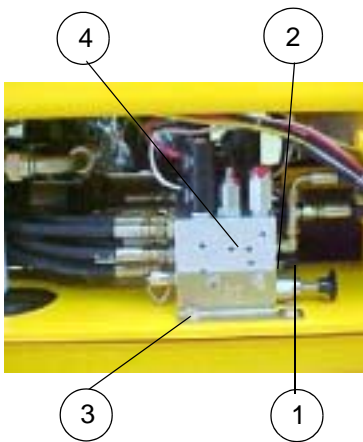

Compact

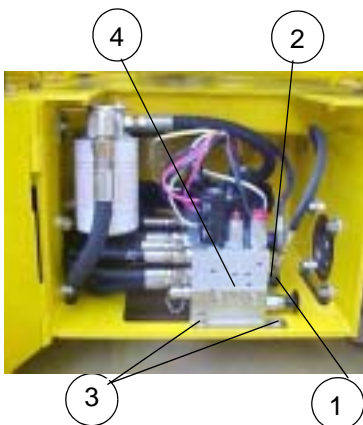

Optimum

	CORRECTIVE MAINTENANCE SHEET	Sheet 2/2

SHEET C021	CORRECTIVE MAINTENANCE SHEET	Sheet 1/2
	REPLACING A WHEEL	

1 - Preliminary operations

- Put the machine in the low configuration.
- Cut off the electric power supply (see § 7.3, page 52).
- Raise the machine using a jack or hoist.

2 - Removing a wheel

- Remove the pin (1) and fixing nut (2) from the wheel and remove the wheel (3).

3 - Replacing a wheel

- Replace the key (4) if necessary.
- Put a new wheel into place and secure with the fixing nut and pin.
- Put the machine back into the operational configuration.

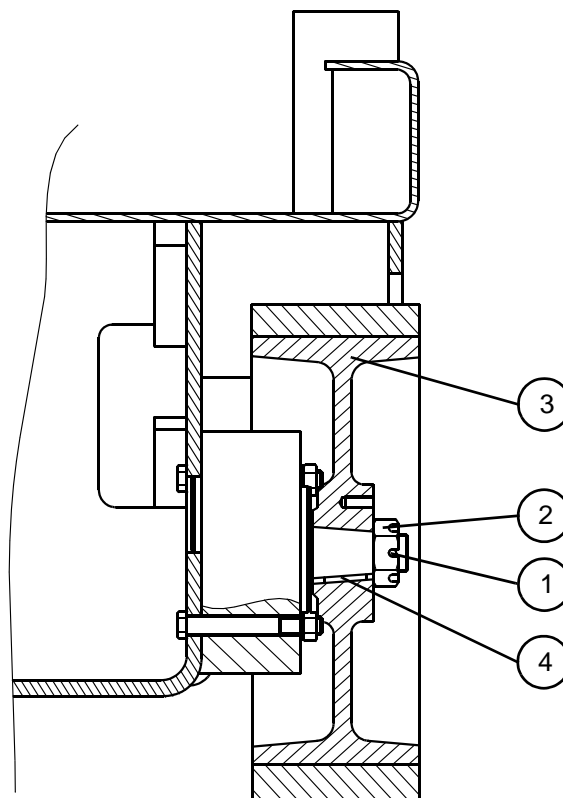

Wheel nut tightening torque : 25 N/m / 18 lbf.ft

To fix the pin, the slot must be in front of an hole : at this time we can screw until 30 N/m / 22 lbf.ft.

	CORRECTIVE MAINTENANCE SHEET	Sheet 2/2

SHEET C022	CORRECTIVE MAINTENANCE SHEET	Sheet 1/2
	REPLACING THE BRAKE RELEASE HAND PUMP	

1 - Preliminary operations

- Put the machine in the maintenance configuration (see § 7.2, page 51).
- Cut off the electric power supply (see § 7.3, page 52).
- Check that the brake release valve NV1 is open.

Caution!
Ensure that oil temperature is not too high.

2 - Removing the brake release hand pump

- Unscrew the brake release hand pump (1) and take it out of the hydraulic block.
- Put a cap on the hydraulic block hole to protect it.

3 - Replacing the manual brake hand pump

- Screw a new brake release hand pump into place.
- Put the machine back in the operational configuration.
- Apply and release the brakes manually several times to purge the hydraulic circuit.

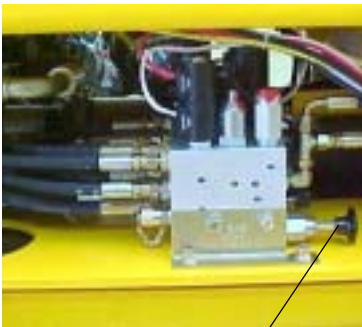

Compact



Optimum

	CORRECTIVE MAINTENANCE SHEET	Sheet 2/2

SHEET C023	CORRECTIVE MAINTENANCE SHEET	Sheet 1/2
	REPLACING THE STEERING CYLINDER	

Caution!
Ensure that oil temperature is not too high.

1 - Preliminary operations

- Put the machine in the low configuration.
- Cut off the electric power supply (see § 7.3, page 52).
- Raise the machine with a jack or hoist.

2 - Removing the steering cylinder

- Mark and disconnect the two steering cylinder hoses (1).



NB: Unscrew the hose slowly to allow residual hydraulic pressure to dissipate.

- Fit caps to the hoses.
- Put the cylinder into slings.
- Remove the screws (3) and blocking yokes (4) then remove the steering cylinder's two axles (2).
- Remove the steering cylinder.

1

3 - Replacing the steering cylinder

- Put a new steering cylinder into place.
- Replace the axles and blocking yokes and secure with screws equipped with new toothed washers.
- Reconnect the hydraulic hoses according to the marks made when dismantling.
- Put the machine back into the operational configuration.
- Make several steering movements to purge the hydraulic circuit.
- Check the oil level in the hydraulic oil tank.

3 2 4



	CORRECTIVE MAINTENANCE SHEET	Sheet 2/2

SHEET C024	CORRECTIVE MAINTENANCE SHEET	Sheet 1/2
	REPLACING A POTHOLE CYLINDER	

1 - Preliminary operations

- Put the machine into the maintenance configuration (see § 7.2, page 51).
- Cut off the electric power supply (see § 7.3, page 52).

Caution!

Ensure that oil temperature is not too high.

2 - Removing a pothole cylinder

- Mark and disconnect the two hoses (2) of the pothole cylinder (1). Fit caps to the hoses.
- Remove the special screw (5), washer (6) and nut (7) from the lower axle.
- Remove the pin (3) and washer (4) from the cylinder's upper joint and remove the pothole cylinder.

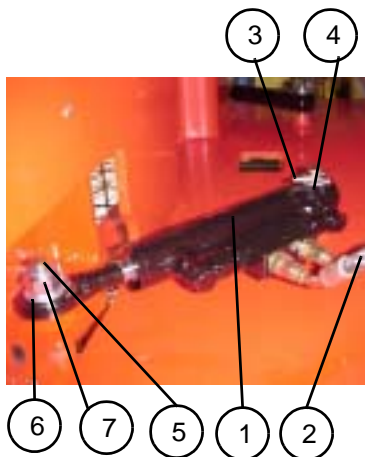

3 - Replacing a pothole cylinder

- Put a new pothole cylinder into place on the upper axle.
- Put the washer into place and secure a new pin.
- Fix the pothole cylinder rod yoke with the special screw, washer and a new nut.
- Reconnect the hydraulic hoses according to the marks made when dismantling.
- Put the machine back into the operational configuration.
- Perform several up/down movements from the platform above 1.5 meters (or 4ft9.2in) and travel movements with the platform lowered to purge the hydraulic circuit.
- Check that the pothole protective system extends and retracts correctly.

NOTA : *If counterweights are fitted with the potholes, check that their position remains correct before replacing the cylinder.*

	CORRECTIVE MAINTENANCE SHEET	Sheet 2/2

SHEET C025	CORRECTIVE MAINTENANCE SHEET	Sheet 1/2
	REPLACING A PLATFORM EXTENSION	

1 - Preliminary operations

- Put the machine in the low position.
- Cut off the electric power supply (see § 7.3, page 52).

2 - Removing the platform extension

- Remove the electric plug and its support, if any, from the platform.
- Remove the control panel (1) and the platform wiring harness (2).
- Put the platform extension (3) into slings.
- Remove the locking pedal (4) and support (5) assembly.
- Remove the two roller and roller axle assemblies at the back of the extension by unscrewing the fixing screws (6).
- Remove the two safety brackets (7).
- Remove the platform extension.



Compact

3 - Replacing the platform extension

- Put the platform extension into place.
- Secure the two safety brackets.
- Put the locking pedal and support assembly, the two rollers and their axles back into place and secure with screws equipped with new toothed washers.
- Install the electric plug support.
- Put the platform control panel back into place and reconnect the platform wiring harness.
- Grease the friction parts of the slides.

NB: *Only use the grease recommended by the manufacturer.*



Optimum

- Put the machine back into the operational configuration.
- Check that the platform extension can be extended and retracted easily.

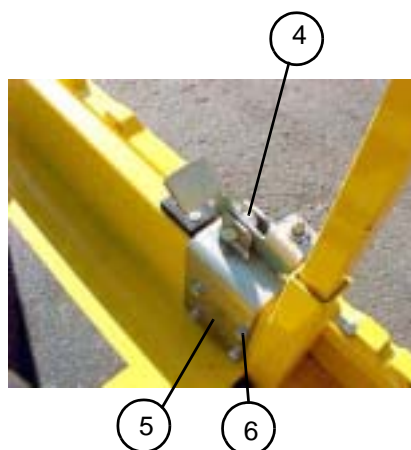

Compact

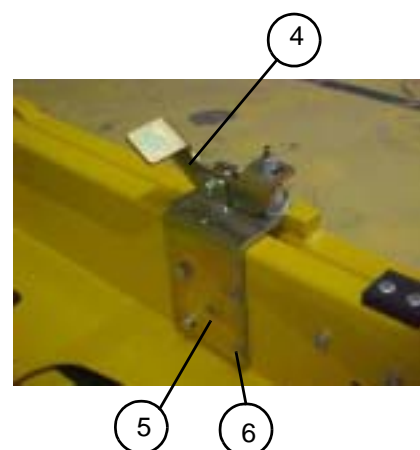

Optimum

•

	CORRECTIVE MAINTENANCE SHEET	Sheet 2/2

SHEET C026	CORRECTIVE MAINTENANCE SHEET	Sheet 1/2
	REPLACING THE PLATFORM	

1 - Preliminary operations

- Put the machine in the low position.
- Cut off the electric power supply (see § 7.3, page 52).

2 - Removing the platform

- Disconnect the wiring harness (1) from the platform control panel.
- Remove the control panel and remove the wiring harnesses from the platform.
- Remove the electric plug and its support, if any, from the platform.
- Put the platform into slings.
- Remove the axle stop bolts from the four platform axles (two fixed axles (2) and two moving axles (3)) and remove the four axles.
- Remove the platform.
- Remove the four pads and check their condition, remove the adjustment wedges if necessary.



1

3 - Replacing the platform

- Put the four pads into place (fixed and moving) on the platform.
- Put the platform on the scissors.
- Put the four fixed and moving platform axles into place and secure with the axle stop bolts.

NB: *Fit the bolts so that the screw is on the outside of the platform and the nut on the inside (see diagram).*

2



- Remount the electric plug, if applicable, on the platform.
- Put back the platform control panel.
- Grease the slides using a spatula

NB: *Only use the grease recommended by the manufacturer.*

3

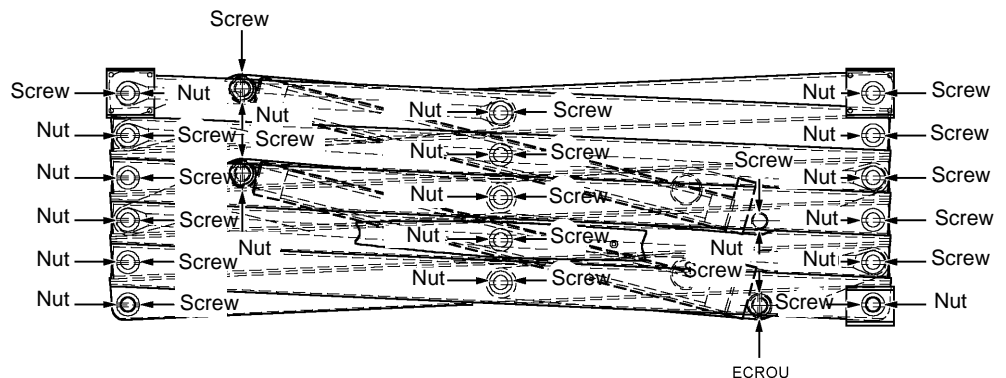

- Put the machine back into the operational configuration.
- Perform several lifting cycles to check that the machine works properly.

	CORRECTIVE MAINTENANCE SHEET	Sheet 2/2

SHEET C027	CORRECTIVE MAINTENANCE SHEET	Sheet 1/2
	REPLACING THE SCISSORS	

1 - Preliminary operations

- Put the machine in the low position.
- Cut off the electric power supply (see § 7.3, page 52).

2 - Remove the scissors

- Remove the platform (see SHEET C025).
- Remove the lifting cylinder(s) (see SHEET C001).
- Mark and remove the hydraulic hoses and electric wiring harness routed along the scissors.
- Fit caps on the hoses and hydraulic equipment.
- Put the scissors into slings.
- Remove the two axle stop bolts (8) on the two fixed chassis axles.
- Remove the two fixed chassis axles using the threaded holes.
- Remove the scissors and pads.

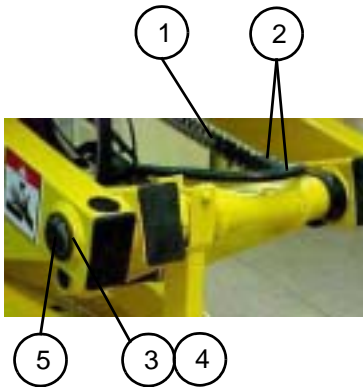

3 - Dismantling the scissors

- Carefully mark the equipment's assembly.
- Remove the cable passage ducts (1):
 - counterbore the eight rivets (2) at both ends of the duct and remove the straps,
 - remove the duct,
 - remove the upper duct stop bracket.
- Put each element into slings and remove, one after the other, removing the elastic rings (3) and washers (4) from the articulation axles (5).

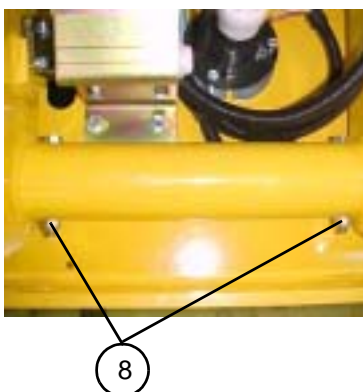

NB: Remove the scissor elements starting from the top.

4 - Reassembling the scissors

- Reassemble according to the dismantling procedure in reverse order, respecting the marks made when dismantling.

5 - Replacing the scissors

- Check the condition of the pads and replace if necessary.
- Put the scissors into slings and into place on the chassis.
- Check that the axial clearance between the chassis and the lower arm (6) does not exceed 1mm; otherwise, adjust the clearance using the adjustment wedges (7) provided (see figure 2).
- Put the two fixed chassis axles into place and secure using the two axle stop bolts.

NB: Fit the bolts so that the screw is on the top of the axle and the nut is underneath (see figure 1).

- Replace the hydraulic hoses and electric wiring harness routed along the scissors, according to the marks made when dismantling.
- Replace the lifting cylinder(s) (see SHEET C001).
- Replace the platform (see SHEET C025).
- Put the machine back into the operational configuration.
- Grease the slides using lead-free grease.

Sheet C027	CORRECTIVE MAINTENANCE SHEET	Sheet 2/2
	REPLACING THE SCISSORS	

NB: Only use the grease recommended by the manufacturer.

- Perform several lifting cycles to check that the machine works properly.

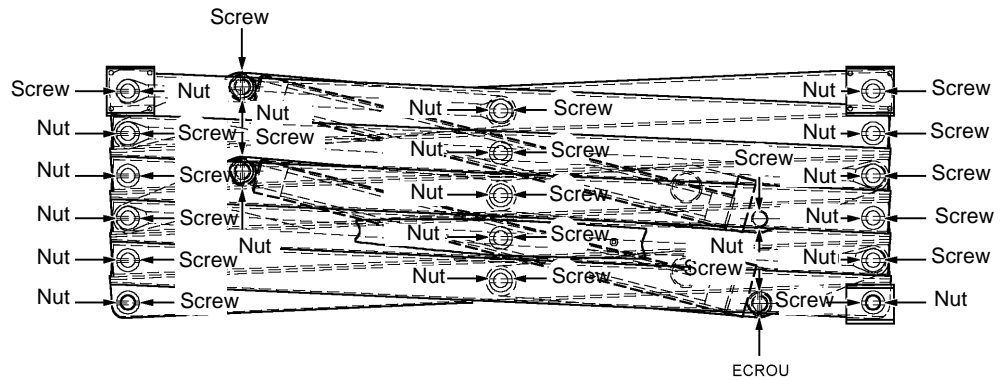

Fig. 1

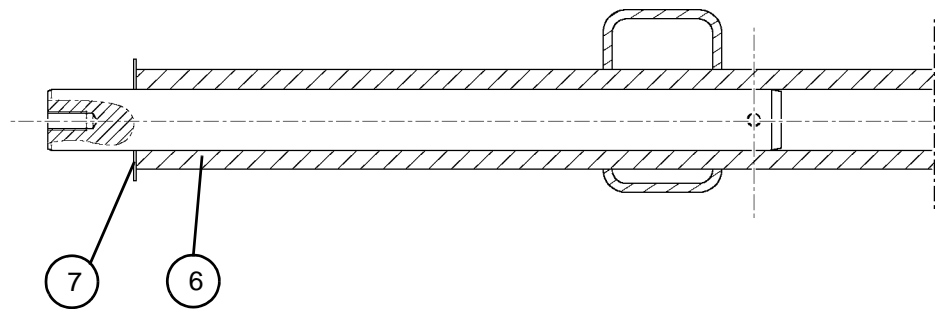

Fig. 2

SHEET C028	CORRECTIVE MAINTENANCE SHEET	Sheet 1/2
	REPLACING A SCISSOR RING OR AXLE	

1 - Preliminary operations

- Put the machine in the low position.
- Cut off the electric power supply (see § 7.3, page 52).

2 - Removing a scissor axle (1) or ring (2)

- Remove the platform (see SHEET C026).
- Remove the elastic ring and washer from the scissor axle in question.
- Remove the axle stop bolt.
- Take out the scissor axle.
- Take out the two scissor rings.

3 - Replacing a scissor axle or ring

- Put new scissor rings into place.
- Put the scissor axle into place and secure using the axle stop bolt.

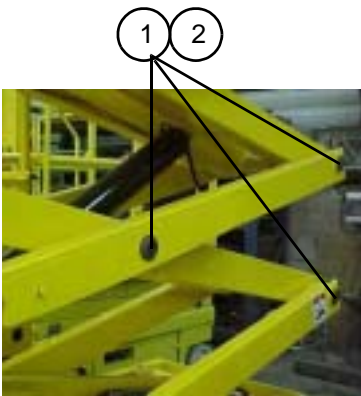

NB: Fit the axle stop bolts so that the screw is above the axle and the nut underneath when the platform is in the high position (see figure below)

- Put the washer and elastic ring back into place.
- Put the platform back (see SHEET C026).
- Put the machine back into the operational configuration.
- Make several lifting movements and check that the scissors work properly.

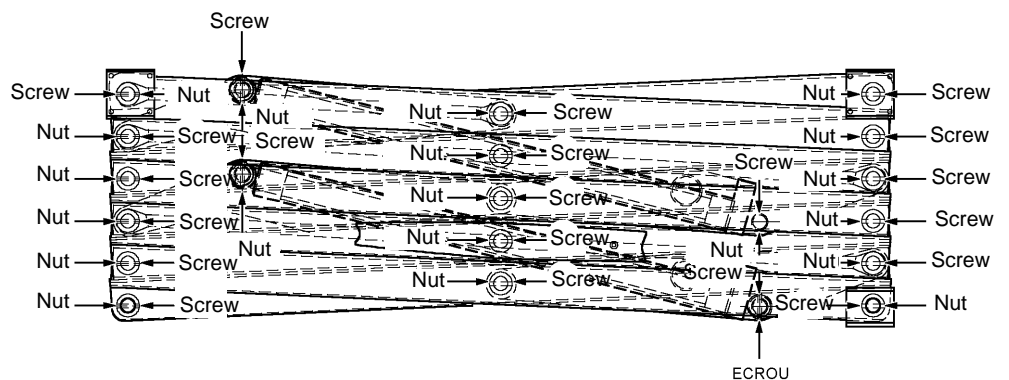

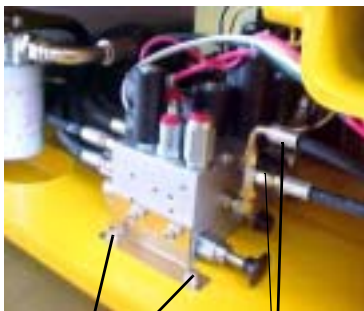

Fig. 1

	CORRECTIVE MAINTENANCE SHEET	Sheet 2/2

SHEET C029	CORRECTIVE MAINTENANCE SHEET	Sheet 1/1
	REPLACING THE BALANCING VALVES	

 **Caution!**
Ensure that oil temperature is not too high.



Compact



Optimum

1 - Preliminary operations

- Put the machine in the low position.
- Cut off the electric power supply (see § 7.3, page 52).

2 - Removing the balancing valves

- Disconnect the hydraulic brake hoses (2) and close the holes on the pipework and hydraulic block.
- Unscrew the two screws (1) of the fixing lug and take out the hydraulic block.
- Remove the balancing valves (3) by unscrewing them.

3 - Replacing the balancing valves

- Screw the new balancing valves (whose characteristics correspond to the machine in question) into the hydraulic block.
- Put the hydraulic block back into place and secure using the screws (1) equipped with new flat and toothed washers.
- Reconnect the hydraulic brake hose onto the block.
- Make several travel movements to purge the circuit.
- Position the machine on a 40% slope and check that the machine does not go into runaway during a travel movement.

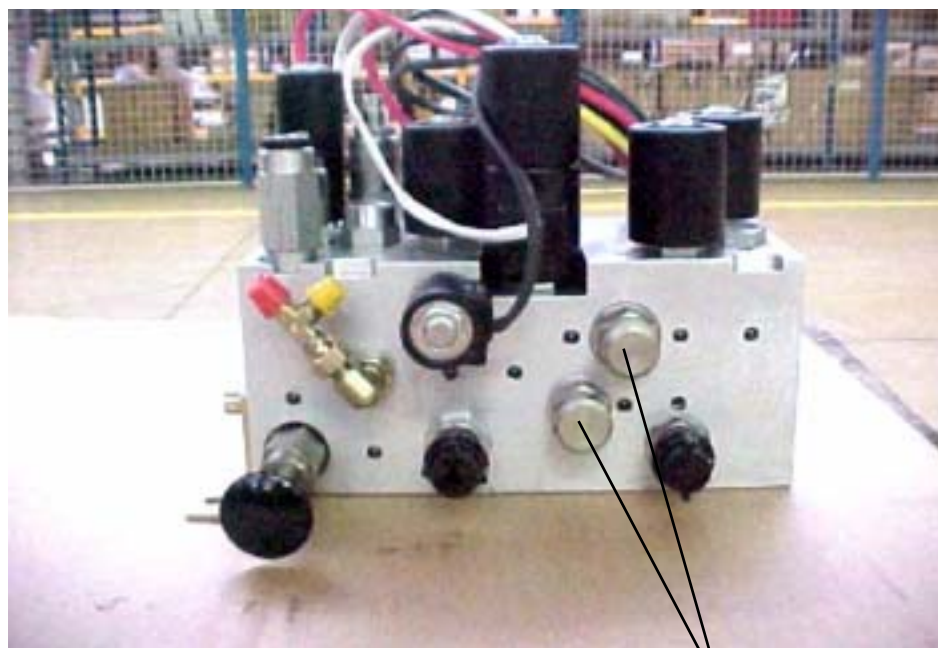

 **Caution!**
The balancing valves are safety elements.
They are calibrated in the plant and must not be re-adjusted.

	CORRECTIVE MAINTENANCE SHEET	

<i>SHEET C030</i>	CORRECTIVE MAINTENANCE SHEET	Sheet 1/1
	REPLACING A CARTRIDGE ELECTROVALVE	

1 - Preliminary operations

- Put the machine in the maintenance configuration (see § 7.2, page 51).
- Cut off the electric power supply (see § 7.3, page 52).

 **Caution!**
Ensure that oil temperature is not too high.

2 - Removing a cartridge electrovalve

- Remove the coil(s) (2) of the electrovalve (see SHEET C007).
- Unscrew the electrovalve (1) with the Allen key and remove from the hydraulic block.

3 - Replacing a cartridge electrovalve

- Screw a new electrovalve, equipped with its seal, into the hydraulic block.
- Put the coil(s) back into place on the electrovalve and put the hydraulic block back into place (see SHEET C007).
- Put the machine back into the operational configuration.
- Perform several movements using the replaced electrovalve to check that it works properly.

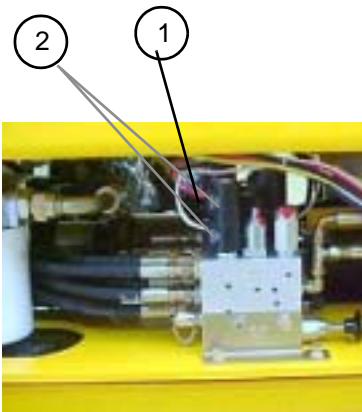

Compact

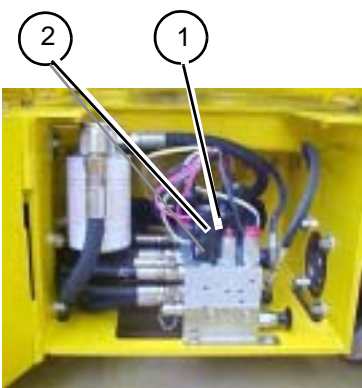

Optimum

	CORRECTIVE MAINTENANCE SHEET	

<i>SHEET C031</i>	CORRECTIVE MAINTENANCE SHEET	Sheet 1/1
	REPLACING THE CHASSIS EMERGENCY STOP BUTTON	

 **Caution!**
Do not use the machine during maintenance operations.

1 - Preliminary operations

- Put the machine in the maintenance configuration (see § 7.2, page 51).
- Disconnect the + and - terminals of the batteries to isolate the electric circuit.

2 - Remove the emergency stop button

- Mark and disconnect the emergency stop button's electric connections (1).
- Remove the emergency stop button (2).

3 - Replacing the emergency stop button

- Put a new emergency stop button into place.
- Reconnect the electric connections according to the marks made when dismantling.

4 - Test

- Put the machine back into the operational configuration.
- Check that the emergency stop button works properly.



Compact



Optimum



Optimum



Compact

	CORRECTIVE MAINTENANCE SHEET	

SHEET C032	CORRECTIVE MAINTENANCE SHEET	Sheet 1/2
	REPLACING THE HYDRAULIC PUMP	

1 - Preliminary operations

- Put the machine in the maintenance configuration (see § 7.2, page 51).
- Cut off the electric power supply (see § 7.3, page 52).

**Caution!**

**Ensure that oil temperature
is not too high.**

2 - Removing the hydraulic pump

- Remove the motorpump set (see SHEET C019).
- Remove the screws securing the pump to the motor and remove the pump.

3 - Replacing the hydraulic pump

- Put a new pump equipped with seal onto the electric motor and secure with the fixing screws.
- Remount the motor pump set (see SHEET C019).
- Put the machine back into the operational configuration.
- Perform several lifting cycles to purge the hydraulic circuit.
- Check the oil level in the hydraulic oil tank.

	CORRECTIVE MAINTENANCE SHEET	Sheet 2/2

SHEET C033	CORRECTIVE MAINTENANCE SHEET	Sheet 1/1
	REPLACING AND ADJUSTING A PRESSURE SWITCH	

Caution!
Ensure that oil temperature is not too high.

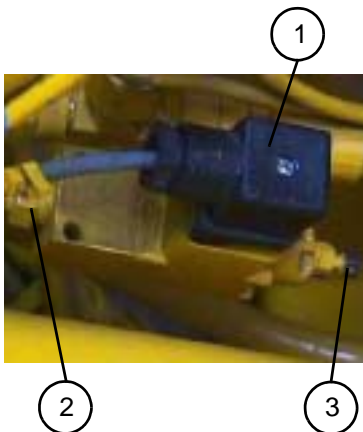

1 - Preliminary operations

- Put the machine in the maintenance configuration (see § 7.2, page 51).
- Cut off the electric power supply (see § 7.3, page 52).
- Check low pressure with the emergency control.

2 - Removing the pressure switch

- Disconnect the lifting electric connector (1) from the lifting cylinder's pressure switch.
- Disconnect the pressure switch's hydraulic hose (2).
- Fit a cap to the hose.
- Unscrew and remove the pressure switch fixing screws.

3 - Replacing the pressure switch

- Screw a new pressure switch, equipped with its seal, into place.
- Reconnect the pressure switch's hydraulic hose.
- Reconnect the pressure switch's electric connector.
- Put the machine back into the operational configuration.

4 - Adjusting the pressure switch

- Place a load corresponding to «movement disabling load» in the platform (see table below), raise the platform until the small rod of the lifting cylinder is disengaged and adjust the pressure switch screw (3) located on the lifting cylinder so that the movements are disabled for this given load.
- Check that the machine works properly in all positions with a load slightly less than nominal load on the platform.

Machine	Nominal load	Load setting for disabling movements
H8SN 2032E	outdoor use: 120kg / 265 lb indoor use: 350kg / 770 lb	outdoor use: 120kg / 265 lb indoor use: 350kg / 770 lb
H8SW 2247E	outdoor use: 120kg / 265 lb indoor use: 450kg / 990 lb	outdoor use: 120kg / 265 lb indoor use: 450kg / 990 lb
H10N 2632E	indoor use only: 230 kg / 500 lb	indoor use only: 230 kg / 500 lb
H10S 2747E	outdoor use: 120kg / 265 lb indoor use: 450kg / 990 lb	outdoor use: 120kg / 265 lb indoor use: 450kg / 990 lb
H12SN 3347E	outdoor use: 120kg / 265 lb indoor use: 300kg / 660 lb	outdoor use: 120kg / 265 lb indoor use: 300kg / 660 lb
Optimum 6 1530E	outdoor use: 115kg / 254 lb indoor use: 270kg / 595 lb	outdoor use: 115kg / 254 lb indoor use: 270kg / 595 lb
Optimum 8 1930E	indoor use: 230kg / 500 lb	indoor use: 230kg / 500 lb

(tolerance: + or - 10%)