

Part No.514004110002

Rev: C

Nov. 2022

# Maintenance Manual

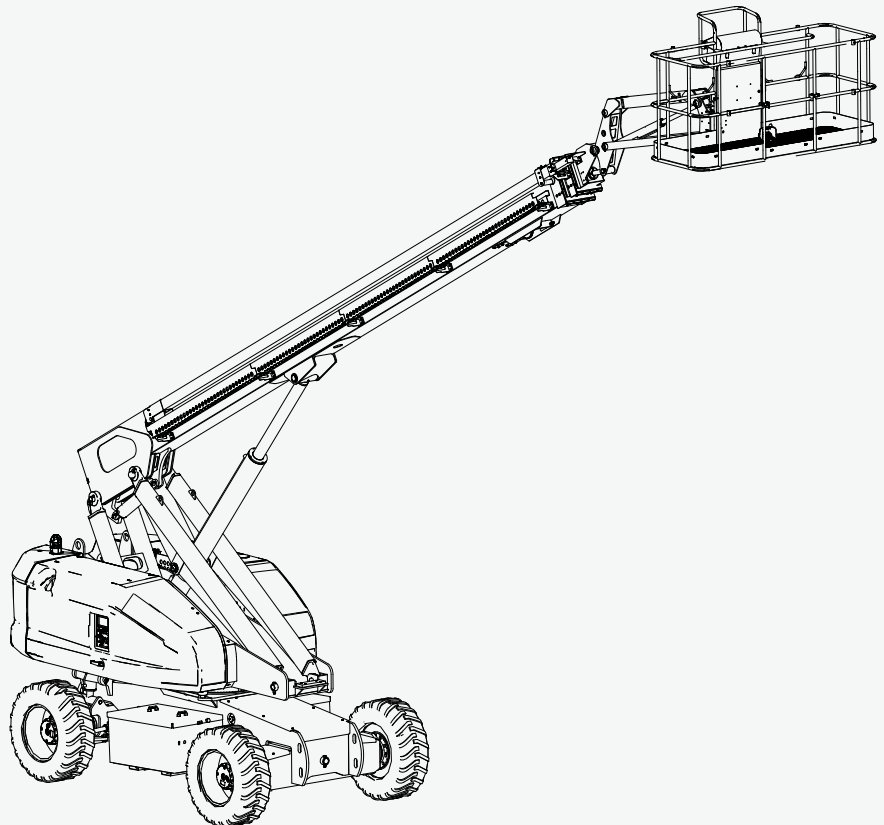
---

**TB24E Plus/TB800E Plus**

**TB26EJ Plus/TB860EJ Plus**

**TB26E Plus/TB850E Plus**

**TB28EJ Plus/TB910EJ Plus**



CE *ANSI* GB

**SINOBOOM**



 **WARNING**

Operating, servicing and maintaining this vehicle or equipment can expose you to chemicals including engine exhaust, carbon monoxide, phthalates, and lead, which are known to the State of California to cause cancer and birth defects or other reproductive harm. To minimize exposure, avoid breathing exhaust, do not idle the engine except as necessary, service your vehicle or equipment in a well-ventilated area and wear gloves or wash your hands frequently when servicing. For more information go to: [www.P65warnings.ca.gov](http://www.P65warnings.ca.gov).  
For disposal, please follow your nation regulation.

## Manual revision history:

REV	DATE	DESCRIPTION	REMARK
A	Oct. 2021	Original issue	
B	Mar. 2022	Revised version, changed to open-circuit variable displacement pump	
C	Nov. 2022	Updated manual, implemented the BS EN 280-1:2022 standard requirements, revised the logic description of drive speed select switch etc.	

### Please contact us:

Website : [www.sinoboom.com](http://www.sinoboom.com)

E-mail : [sales@sinoboom.com](mailto:sales@sinoboom.com)

Sales Tel : 0086-0731-87116222

Service Tel : 0086-0731-87116333

Address : No.128, East Jinzhou Avenue, Ningxiang High-tech Industrial Park, Changsha, Hunan, China

Zip Code : 410600

Copyright © Hunan Sinoboom Intelligent Equipment Co., Ltd. All Rights Reserved

The final interpretation right of this manual belongs to Hunan Sinoboom Intelligent Equipment Co., Ltd.

# APPLICABLE RANGE

Use the following table to identify the specific serial number for models included in this manual. Check the model of your machine before consulting the manual, and then use the correct manual according to the serial number of the model. See the nameplate on your machine to identify the model and serial number. (See *Decals/Nameplate Inspection* of the *Operation Manual* for details.)

Model	Trade Identification		Serial No.
	Metric	Imperial	
TB24E Plus	TB24E Plus	TB800E Plus	From 1400300100 to present
TB26EJ Plus	TB26EJ Plus	TB860EJ Plus	From 1400400231 to present
TB26E Plus	TB26E Plus	TB860E Plus	From 1401100100 to present
TB28EJ Plus	TB28EJ Plus	TB910EJ Plus	From 1400700274 to present

## NOTE:

- Product model is applied in product nameplate for distinction of products of different main parameters.
- Product trade identification is applied in marketing and machine decals for distinction of products of different main parameters, and can be classified as metric type and imperial type: The metric trade identification is applicable to machines for countries/regions using metric system or as specially required by customers; The imperial trade identification is applicable to the machines for countries/regions using imperial system or as specially required by customers.

**This Page Intentionally Left Blank**

# STATEMENTS

Hunan Sinoboom Intelligent Equipment Co., Ltd. (Hereinafter referred to as Sinoboom) will upload the latest product manual information to the website [www.sinoboom.com](http://www.sinoboom.com) as soon as possible. However, due to continuous product improvement, the information in this manual is subject to change without prior notice.

This manual covers the basic parts information of one or more products. Therefore, please use this manual according to your needs. If you find problems in the manual or have suggestions for improvement, feel free to share your feedback with Sinoboom, and we will address these issues as soon as possible.

Feel free to consult and download the *Operation Manual*, *Maintenance Manual* and *Parts Manual* of the products you need online at [www.sinoboom.com](http://www.sinoboom.com).

Hunan Sinoboom Intelligent Equipment Co., Ltd. retains the right of final interpretation of the manual.

---

**SINOBOOM**



All of the above are registered trademarks of Hunan Sinoboom Intelligent Equipment Co., Ltd..

**This Page Intentionally Left Blank**

# TABLE OF CONTENTS

<b>Introduction</b> .....	<b>v</b>	Electrical System.....	3-1
<b>1 Safety</b> .....	<b>1-1</b>	Machine Control.....	3-1
Safety Definitions .....	1-1	Safety Measures .....	3-1
Reporting Accidents.....	1-1	<b>4 Service and Guidelines</b> .....	<b>4-1</b>
Electrocution Hazards.....	1-2	Machine Preparation, Inspection and	
Tipping Hazards and Rated Load .....	1-2	Maintenance .....	4-1
Jobsite Hazards .....	1-4	General .....	4-1
Unsafe Operation Hazards.....	1-6	Preparation, inspection and	
Fall Hazards.....	1-7	maintenance .....	4-1
Collision Hazards .....	1-7	Qualified Sinoboom equipment	
Crush Hazards .....	1-8	mechanic .....	4-1
Explosion and Fire Hazards.....	1-9	Pre-operation inspection.....	4-1
Damaged Machine Hazards .....	1-9	Pre-delivery inspection and	
Bodily Injury Hazards .....	1-9	frequent inspection .....	4-1
Battery Hazards .....	1-10	Annual machine inspection .....	4-1
Hydraulic Hazards .....	1-12	Preventive maintenance .....	4-2
Welding and Polishing Requirements	1-12	Storage .....	4-3
After Using the Machine.....	1-12	Maintenance and Servicing	
<b>2 Specifications</b> .....	<b>2-1</b>	Precautions .....	4-3
Machine Specifications .....	2-1	General .....	4-3
Motor Specifications .....	2-11	Safety and workmanship .....	4-3
Function Speed .....	2-12	Cleanliness .....	4-4
Weight of Major Components .....	2-12	Component removal and installation	4-4
Hydraulic System Specifications .....	2-14	Component disassembly and	
Hydraulic Hose and Fitting		assembly .....	4-4
Specifications .....	2-14	Scrap of structural parts .....	4-4
Hydraulic Hose Torque .....	2-14	Pressure-fit parts .....	4-5
Hydraulic Fitting Torque .....	2-15	Bearings .....	4-5
Hydraulic Hose and Fitting Tight-		Gaskets.....	4-5
ening Procedure .....	2-17	Bolt usage and torque application ..	4-5
Fastener Torque Specifications .....	2-17	Hydraulic lines and electrical wiring	4-5
<b>3 System Descriptions</b> .....	<b>3-1</b>	Hydraulic system .....	4-5
Power Source .....	3-1	Lubrication.....	4-5
Hydraulic System .....	3-1	Battery .....	4-5
		Pins and composite bearing.....	4-5

Application of Insulating Silicone Grease to Electrical Connections ..... 4-6

## **5 Maintenance Procedures ..... 5-1**

Conducting a Pre-delivery Inspection . 5-1

Following a Maintenance Schedule ... 5-2

Completing a Repair & Inspection Report..... 5-2

Major Modification and Repair Record 5-5

Checklist A Procedures ..... 5-6

A-1 Inspect All Manuals..... 5-6

A-2 Inspect All Decals ..... 5-6

A-3 Inspect Damaged, Loose or Lost Parts ..... 5-6

A-4 Inspect Hydraulic Oil Level ..... 5-6

A-5 Inspect Hydraulic Leakage ..... 5-7

A-6 Functional Tests ..... 5-7

A-7 Perform Maintenance after 30 Days ..... 5-11

A-8 Exhaust Oscillate Cylinder ..... 5-11

A-9 Check Battery Level ..... 5-11

Checklist B Procedures ..... 5-12

B-1 Replace Hydraulic Oil Tank Return Filter Element ..... 5-12

B-2 Inspect Rim, Tire and Fasteners ..... 5-12

B-3 Inspect Hydraulic Oil ..... 5-13

B-4 Inspect Electrical Wiring ..... 5-13

B-5 Inspect Emergency Lowering . 5-13

B-6 Inspect Air filter of Hydraulic Tank ..... 5-14

B-7 Replace High-Pressure Filter Element ..... 5-14

B-8 Test Drive Speed ..... 5-15

B-9 Inspect Length and Angle Sensors ..... 5-15

B-10 Inspect Tilt Protection ..... 5-16

B-11 Inspect Drive Reducer Oil Level ..... 5-16

B-12 Inspect Slewing Reducer Oil Level ..... 5-17

B-13 Inspect Slewing Bearing Bolts ..... 5-17

B-14 Lubricate Slewing Bearing ... 5-18

B-15 Inspect Platform Rotate Cylinder Fasteners ..... 5-18

B-16 Test Cylinder Drift ..... 5-19

B-17 Test Counterbalance Valve Locking ..... 5-19

B-18 Test Oscillate Outriggers ..... 5-20

B-19 Inspect Battery ..... 5-20

B-20 Test Braking Distance ..... 5-21

Checklist C Procedures ..... 5-21

C-1 Inspect Boom Extending/Retracting Wire Ropes and Pulleys ..... 5-21

C-2 Replace Air filter of Hydraulic Tank ..... 5-22

C-3 Inspect Weighing System ..... 5-22

Checklist D Procedures ..... 5-23

D-1 Replace Drive Reducer Gear Oil ..... 5-23

D-2 Replace Slewing Reducer Gear Oil ..... 5-23

D-3 Replace Hydraulic Oil ..... 5-23

D-4 Replace Hydraulic Tank Suction Filter ..... 5-24

D-5 Inspect Boom Wear Pads ..... 5-24

## **6 Repair Procedures ..... 6-1**

Boom and Platform Components ..... 6-1

Boom and Platform Systems ..... 6-1

Platform Controller ..... 6-2

Platform ..... 6-2

Platform Rotate Motor ..... 6-2

Jib Boom Assembly (TB26EJ Plus&28EJ Plus only) ..... 6-3

Platform Level Cylinder ..... 6-3

Cable Track Assembly ..... 6-4

- Steel Cable Tensioning Adjustment. 6-4
- Main Boom Assembly ..... 6-5
- Chassis and Turntable Components .. 6-6
  - Tires and Rims..... 6-6
  - Turntable Slewing Mechanism..... 6-7
  - Battery Box ..... 6-11
  - Battery ..... 6-11
- Hydraulic System ..... 6-12
  - Layout of Hydraulic Elements..... 6-12
  - Function Manifold..... 6-14
  - Hydraulic Symbols..... 6-21
  - Hydraulic Schematic..... 6-22
- Electrical System..... 6-26
  - Fault Code Description ..... 6-26
  - Use and Maintenance of Battery... 6-44
  - Electrical Symbols ..... 6-47
  - Electrical Schematic ..... 6-49

**7 Control system ..... 7-1**

- Display interface ..... 7-1
- Main interface after booting ..... 7-3
- Description of icon function ..... 7-3
- Language setting..... 7-4
- Test-run information..... 7-5
  - Sensor calibration ..... 7-5
  - Weight calibration..... 7-6
  - Joystick calibration ..... 7-6
- Advanced setting..... 7-7
  - Sensor configuration..... 7-7
  - Turntable enable..... 7-7
  - Standardization ..... 7-8
  - Proportional configuration ..... 7-9
  - Parameter restore/save..... 7-11
- System information ..... 7-12
  - Time setting..... 7-12
  - Sensor information ..... 7-12
  - Digital input information..... 7-13
  - Digital output information ..... 7-13
  - Proportional information ..... 7-14

- Engine information (for models equipped with an engine) ..... 7-14
- Turntable panel information ..... 7-17
- Platform information..... 7-17
- Alarm information ..... 7-18

**Appendix 1: Prepare the Work Record before Delivery..... A-1**

**Appendix 2 : Repair & Inspection Report ..... A-3**

**Appendix 3: Major Modification and Repair Record ..... A-7**



# INTRODUCTION

Thank you for choosing and using the machinery of Hunan Sinoboom Intelligent Equipment Co., Ltd. Always read, understand and become familiar with the operation requirements of the machine and its associated safety procedures before operating, maintaining and repairing the machine. Operating the machine without becoming familiar with its specific operation requirements and safety procedures poses serious risks. Operators who follow safety rules and operate the machine carefully and effectively will prevent personal injury, property loss and accidents.

Use this machine only to transport tools to work locations and for performing tasks on the work platform. Operators must be competent and must obtain training to carefully use the machine and follow safety procedures. Only trained and authorized personnel may operate the machine.

This manual guides the operator and authorized personnel in maintaining the machine. The operator is responsible for reading, understanding and implementing the maintenance and safety procedures in this manual and for following the manufacturer's instructions before beginning any work. Read, understand and follow all safety rules and operating instructions. The operator must also consider the machine's uses and limitations and the conditions at the jobsite before using this machine. Strictly following all safety requirements in this manual is critical.

Consider this manual a part of the machine, along with *Operation Manual* and *Parts Manual*, and always keep the manuals with the machine. The owner or administrator of the machine shall offer all manuals and other necessary information provided by the machine manufacturer regarding the daily inspection and maintenance to each of the renters. If the machine is sold, the owner or administrator must pass along the manuals and other necessary information to the purchaser. The owner or administrator of the machine shall also provide the manufacturer's maintenance information to the person responsible for maintaining the machine.

If you have any questions, contact Hunan Sinoboom Intelligent Equipment Co., Ltd..

**This Page Intentionally Left Blank**

# 1 SAFETY

Read, understand and comply with the safety rules and regulations of your workplace and your government.

Before using the machine, ensure the operator is properly trained and qualified in safely operating the machine. The training includes but is not limited to :

- Warning and instruction decals on the machine
- Pre-operation inspection
- Any factors that may affect the machine stability
- Common hazards and countermeasures
- Jobsite inspection
- Functions of all controls and associated knowledge, including emergency control.
- Personal protection equipment that suits the task, workplace and environment.
- Safety operation
- Transporting the machine
- Measures against unauthorized use
- Operating instructions

Understand that as the operator you have the responsibility and right to shut down the machine in case of failure with the machine or other emergency at your workplace.

## NOTICE

*People suffering from heart disease, hypertension, epilepsy and other diseases and people who fear heights must never operate or use this machine. Also, people who have alcohol or drugs in their system, or experience excessive fatigue or depression, are prohibited from operating or using this machine.*

## SAFETY DEFINITIONS



This safety alert symbol appears with most safety statements. It means attention, become alert, your safety is involved! Please read and abide by the message that follows the safety alert symbol.

## DANGER

Indicates a hazardous situation that, if not avoided, **will** result in death or serious injury.

## WARNING

Indicates a hazardous situation that, if not avoided, **could** result in death or serious injury.

## CAUTION

Indicates a hazardous situation that, if not avoided, **could** result in minor or moderate injury.

## NOTICE

*Indicates a situation that can cause damage to the engine, personal property and/or the environment, or cause the equipment to operate improperly.*

**NOTE:** Indicates a procedure, practice or condition that should be followed in order for the engine or component to function in the manner intended.

## REPORTING ACCIDENTS

In case of any accident involving the machinery of Hunan Sinoboom Intelligent Equipment Co., Ltd., notify Hunan Sinoboom Intelligent Equipment Co., Ltd. Immediately, even if no personal injury or property damage occurs during the accident. Contact Hunan Sinoboom Intelligent Equipment Co., Ltd. by telephone and provide all necessary details. Failure to notify the manufacturer within 48 hours of the incident involving the machinery of Hunan Sinoboom Intelligent Equipment Co., Ltd. may void the product's warranty.

## NOTICE

*Thoroughly inspect the machine and all its functions after any accident, being sure to test first from the ground controller and then from the platform controller. Ensure the machine's lifting height does not exceed 3 m(9.8 ft) until all damage has been repaired and all controllers operate properly.*

## ELECTROCUTION HAZARDS

**NOTE:** This machine is not insulated and does not have an electric shock protection function.


All operators and managers shall comply with national or local regulations regarding the minimum safe distance of live conductors above the ground. In the absence of such requirements, operators and managers should follow the minimum safety distance requirements in [Table 1-1 Minimum Safe Distance, page 1-2](#).

## TIPPING HAZARDS AND RATED LOAD




Maximum rated load bearing capacity of the platform:

**Table 1-2**

Metric	300kg (unrestricted / 2 persons & tools) 454kg (restricted / 3 persons & tools)
Imperial	661 lb (unrestricted / 2 persons & tools) 1000 lb (restricted / 3 persons & tools)


**WARNING**

**ELECTRICAL SHOCK HAZARDS**

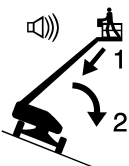
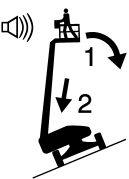
- Always maintain a safe distance from power lines and electrical equipment in accordance with applicable government regulations and see [Table 1-1 Minimum Safe Distance, page 1-2](#).
- Consider platform and boom movement, wire swinging or drooping, beware of strong winds or gusts, and do not operate the machine when there is lightning or heavy rain.
- If the machine comes into contact with live wires, keep away from the machine. Personnel on the ground or on the platform must not touch or operate the machine until the power is switched off.
- Do not use the machine as a ground wire during welding and polishing operations.

**Table 1-1 Minimum Safe Distance**

Voltage (Phase to Phase, kV)	Minimum Safe Distance (m/ft)
0-50	3.05 (10)
50-200	4.60 (15)
200-350	6.10 (20)
350 -500	7.62 (25)
500 -750	10.67 (35)
750 -1000	13.725 (45)

**⚠ WARNING**

**TIPPING HAZARDS**



- Personnel, equipment and materials on the platform must not exceed the maximum platform capacity.
- Only raise or extend the boom when the machine is on solid, level ground.
- Select only the low speed when driving the machine on a slope.
- Do not use the tilt alarm as a level indicator. The tilt alarm on the platform will sound only if the machine is heavily tilted.
- If the tilt alarm sounds when the machine drives up a slope, please lower the boom per the following procedure and move the machine onto firm level ground. Be sure not to rotate the boom when lowering.
  1. Lower the main boom;
  2. Retract the telescopic boom.
- If the tilt alarm sounds when the machine drives down a slope, please lower the boom per the following procedure and move the machine onto firm level ground. Be sure not to rotate the boom when lowering.
  1. Retract the telescopic boom ;
  2. Lower the main boom.
- Do not drive faster than 1.1 km/h (0.68 mph) when the platform is raised.
- When the platform is raised, the machine cannot travel on uneven terrain, unstable surfaces or in other dangerous conditions.
- Do not operate the machine during strong winds or gusts, and do not increase the surface area of the platform or load. Increasing the area exposed to the wind will reduce the stability of the machine.
- When the machine is on rough ground, with gravel or other uneven surfaces, or near holes and steep slopes, maintain a minimum distance of 0.6m (2ft) and reduce the speed.

**⚠ WARNING**

**TIPPING HAZARDS**

- When on the platform do not push and pull objects outside of it. The maximum side force allowed is 600N (135 lbf)restricted/400N (90 lbf) unrestricted.
- Tow the machine only from the tiedown/lifting points on the chassis.
- Never use the boom or platform to stabilize or support any objects outside of the machine.
- Do not change any machine parts that may affect safety and stability.
- Do not replace key parts that affect machine stability with different weights or specifications.
- Do not modify or change moving aerial platforms without the manufacturer's prior written permission.
- On the platform, do not attach an additional device for placing tools or other materials to the guardrail. This will increase the platform weight, surface area and load.
- Do not place on, or fasten any overhanging load to any part of this machine.
- Do not place ladders or scaffolding on the platform or any parts of the machine.
- Do not use the machine on a moving or active surface or on a vehicle. Ensure all tires are in good condition, the slotted nuts tightened and the cotter pins complete.
- Do not use a battery that weighs less than the original one(lead-acid battery 655kg[1444 lb] and lithium battery 240kg[529 lb] ), and do not remove or modify the counterweight or other parts inside the battery box. The battery not only provides power, it also serves as a counterweight. The battery is vital to maintaining the stability of the machine.
- Do not use the platform or boom assembly to push other machines or objects.

**⚠ WARNING**

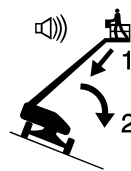
**TIPPING HAZARDS**

- Do not let the platform or boom assembly touch the nearby structures.
- Do not tie off the platform with rope or other binding materials to the nearby structures.
- Do not put a load outside the platform.
- When the platform is caught or stuck or when other objects in the vicinity impede its normal movement, do not use the platform controller to lower the platform. If you intend to lower the platform with a ground controller, you must operate it only after all personnel have left the platform.

**JOBSITE HAZARDS**

**⚠ WARNING**

**JOBSITE HAZARDS**



- Do not operate the machine on surfaces, edges or potholes that cannot bear the weight of the machine. Raise or extend the boom only when the machine is on firm, flat ground.
- Never travel on uneven terrain or unstable surfaces or in other dangerous conditions when raising the platform.
- When the machine is on rough ground, with gravel or other uneven surfaces, or near holes and steep slopes, maintain a minimum distance of 0.6m (2ft) and reduce the speed.
- Do not use the tilt alarm as a horizontal indicator. The tilt alarm on the platform will sound only when the machine is heavily tilted.
- If the tilt alarm sounds when the machine drives up a slope, lower the boom per the following procedure and move the machine onto firm level ground. Be sure not to rotate the boom while lowering.
  1. Lower the main boom;
  2. Retract the telescopic boom.
- If the tilt alarm sounds when the machine drives down a slope, lower the boom per the following procedure and move the machine onto firm level ground. Be sure not to rotate the boom while lowering.
  1. Retract the telescopic boom;
  2. Lower the main boom.
- Running speed should not exceed 1.1km/h (0.68 mph) when the platform rises.
- If the machine can be used outdoors, never operate it during strong winds or gusts. Do not lift the platform when the wind speed exceeds 12.5 m/s (28 mph). If the wind speed increases to beyond 12.5 m/s (28 mph) after the

**⚠ WARNING**

**JOBSITE HAZARDS**

**platform is lifted, fold the platform and stop operating the machine.**

- **Do not use any device that may increase the wind load on the machine.**
- **Do not drive or lift the machine on slopes, steps or vaulted surfaces that exceed the maximum gradeability of the machine.**

Before or during machine operation, check the jobsite for possible hazards and pay attention to the environmental restrictions, including flammable and explosive gas/dust. If the machine is to be used in any other applications, or by any other means, other than those specified by **Sinoboom**, it must be approved or guided by the manufacturer.

Table 1-3

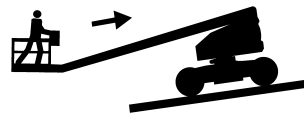
BEAUFORT NUMBER	METERS/SECOND	MILE/HOUR	DESCRIPTION	GROUND CONDITION
0	0 ~ 0.2	0 ~ 0.5	Calm	Calm. Smoke rises vertically.
1	0.3 ~ 1.5	1 ~ 3	Light air	Wind motion visible in smoke.
2	1.6 ~ 3.3	4 ~ 7	Light breeze	Wind felt on exposed skin. Leaves rustle.
3	3.4 ~ 5.4	8 ~ 12	Gentle breeze	Leaves and smaller twigs in constant motion.
4	5.5 ~ 7.9	13 ~ 18	Moderate breeze	Dust and loose paper rise. Small branches begin to move.
5	8.0 ~ 10.7	19 ~ 24	Fresh breeze	Smaller trees sway.
6	10.8 ~ 13.8	25 ~ 31	Strong breeze	Large branches in motion. Flags waving near horizontal. Umbrella use becomes difficult.
7	13.9 ~ 17.1	32 ~ 38	Near gale/ moderate gale	Whole trees in motion. Effort needed to walk against the wind.
8	17.2 ~ 20.7	39 ~ 46	Fresh gale	Twigs broken from trees. Cars veer on road.
9	20.8 ~ 24.4	47 ~ 54	Strong gale	Light structure damage.

**NOTICE**

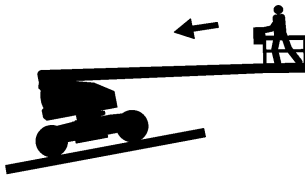
*Maximum gradeability is applicable for machines with platform retracted.*

*Gradeability means the maximum allowable tilt angle of the machine when it is on solid ground and the platform is only capable of carrying one person. As the weight of the machine's platform increases, the machine's climbing capacity reduces.*

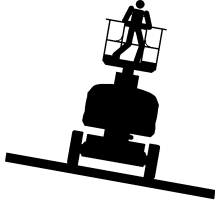
Maximum gradeability :



Uphill: 45%/24°



Downhill: 30%/17°



Side slope: 25%/14°

## UNSAFE OPERATION HAZARDS

At a minimum, operators must operate and maintain the machine as stated in the *Operation Manual* and in the *Maintenance Manual* in addition to following more stringent industry regulations and workplace rules. Never engage in unsafe machine operation.

Do not use the machine in the following situations:

- Unrelated personnel/equipment is present in the working envelope of the machine.
- Use as a crane (except the custom-made ones with such function).
- Use on the truck, trailer, tracked vehicle, ship, scaffold and the like without written consent by the manufacturer or a qualified professional.
- Improper securing of the machine to another object by just leaning, fastening or binding.
- Stunt or imprudent use of the machine.
- Overloaded or over-moment situation.
- Other prohibited situations as specified in the *Operation Manual* and *Maintenance Manual*.

### WARNING

#### UNSAFE OPERATION HAZARDS



- Do not push any object outside the platform. The maximum side force allowed is 600N (135 lbf)-restricted/400N (90 lbf)-unrestricted.
- Tow the machine only from the tie-down/lifting points on the chassis.
- Never use the boom or platform to stabilize or support any objects outside of the machine.
- Do not modify any component that may affect the machine safety and stability.
- Do not replace key parts that affect machine stability with parts of different weights or specifications.
- Do not change or modify the machine without the manufacturer's written permission.
- On the platform, do not attach an additional device for placing tools or other materials to the guardrail. This will increase the platform weight, surface area and load.
- Do not put ladders or scaffolding on the platform or any part of this machine.
- Do not use additional devices to increase the working height of the machine.
- Do not use the machine on any mobile or movable surface or vehicle. Ensure all tires are in good condition, the slotted nuts tightened and the cotter pins complete.
- Do not use a battery that weighs less than the original lead-acid battery (655kg [1444 lb]) or lithium battery (240kg [529 lb]), and do not remove or modify the counterweight or other parts inside the battery box. The battery not only provides power, but also serves as a counterweight. The battery is vital to maintaining the stability of the machine.





**⚠ WARNING**

**UNSAFE OPERATION HAZARDS**

- Do not place or attach any suspended load onto any part of the machine.
- Do not use the machine as a crane or lifting device.
- Do not use the platform to push the machine or other objects.
- Do not allow the platform or boom to touch nearby structures.
- Do not use ropes or other binding materials to tie the platform or boom onto nearby structures.
- Do not put the load outside the platform.
- When the platform is caught or stuck or when other objects in the vicinity impede its normal movement, do not use the platform controller to lower the platform. If you intend to lower the platform with the ground controller, you must operate it only after all personnel have left the platform.
- When one or more of the machine's tires are off the ground, evacuate all personnel before attempting to stabilize the equipment. Use a crane, forklift or other suitable equipment to stabilize the machine.

**⚠ WARNING**

**FALL HAZARDS**

- Each person on the platform must wear harnesses or use safety equipment consistent with government regulations. Fasten the cable to the fixed point of the platform. Never fasten the cable of more than one person to a fixed point on the platform.
- Do not sit, stand or crawl on the guardrails. When on the platform always remain standing on the platform floor.
- Do not enter or exit the platform through the boom.
- Keep the platform floor free of obstacles.
- Do not allow mud, oil stains, grease or other slippery substances reside on the footwear or platform floor.
- Do not enter or exit the platform unless the machine is fully in stowed position.
- Close the platform entrance door before operating the machine.
- Do not operate the machine if the handrails are not properly installed and the platform entry door is not closed.

## FALL HAZARDS

At a minimum, operators must operate and maintain the machine as stated in the operation manual and in the maintenance manual in addition to following more stringent industry regulations and workplace rules.

## COLLISION HAZARDS

At a minimum, operators must operate and maintain the machine as stated in *Operation Manual* and in the *Maintenance Manual* in addition to following more stringent industry regulations and workplace rules.

### ⚠ WARNING

#### COLLISION HAZARDS



- Pay attention to the field of sight and the presence of blind spots when moving or operating the machine.
- Persons except the operator must maintain a distance of at least 1.8m (5.9ft) from the machine while it is travelling or swinging.
- When the work platform of a moving machine is approx. 2m (6.6ft) away from the obstructions, elevate or lower the work platform, rather than directly driving towards the obstructions.
- Switch to the low speed gear before parking the machine that drives at high speed.
- Do not engage the high speed gear when the machine is driving reverse or in restricted or enclosed work area.
- Check the work area to avoid ground and overhead obstructions or other possible risks.
- Be sure to exercise caution when using the platform controller and ground controller. Color-marked directional arrows indicate the functions of travel, lift/lower and steering.
- Users must comply with user, workplace and government rules regarding the use of personal protective equipment (hard hats, safety belts and gloves, etc.).
- Place the machine on level ground or in a secured position before releasing the brake.
- Ensure no people or obstructions are beneath the platform before lowering it.
- When the machine is conducting aerial work, warn the operator/ other people not to work, stand or walk under the raised boom or platform. Set up roadblocks if necessary.
- Limit the speed of travel according to ground conditions, crowding, gradients, the presence and location of personnel and any



### ⚠ WARNING

#### COLLISION HAZARDS

- other factors that may cause collisions.
- Do not operate the machine on the route of any crane or overhead traveling device unless the crane control is locked or precautions have been taken to prevent any potential collision.
- Keep the machine away from any stationary objects (buildings etc.) or mobile objects (vehicles, cranes etc.).
- Never operate a machine in a dangerous way or for fun.

## CRUSH HAZARDS

A potential crush hazard exists during movement of the machine. Always keep body parts and clothing a safe distance from the machine during machine operation.




### ⚠ WARNING

#### CRUSH HAZARDS





- Do not place your hands and arms where they may become crushed or trapped.
- Do not work under the platform or the boom when the boom is not protected by a crane.
- Maintain good judgment and planning when using the controller on the ground to operate the machine. Maintain proper distance between operator, machine and fixed object.

## EXPLOSION AND FIRE HAZARDS

 <b>WARNING</b>	
<b>EXPLOSION AND FIRE HAZARDS</b>	
	<ul style="list-style-type: none"> <li>Do not use the machine or charge the battery in hazardous or potentially flammable or explosive atmosphere.</li> </ul>
	<ul style="list-style-type: none"> <li>For the engine-powered machines, never add fuel while the engine is still running, and only add fuel when the place is well ventilated and free of flame, spark or any other hazards that may cause explosion.</li> <li>Never spray ether on the engine equipped with glow plug.</li> </ul>



## DAMAGED MACHINE HAZARDS

<b>NOTICE</b>
<p><i>To avoid machine damage, follow all operation and maintenance requirements in the Operation Manual and the Maintenance Manual.</i></p>

 <b>WARNING</b>	
<b>DAMAGED MACHINE HAZARDS</b>	
	<ul style="list-style-type: none"> <li>Do not use the machine if it is damaged or not in proper operating condition.</li> <li>Thoroughly inspect and test for all functions of the machine before use. Immediately mark and stop damaged or faulty machines.</li> <li>Ensure that all maintenance operations have been performed in accordance with the <i>Operation Manual</i> and the <i>Maintenance Manual</i>.</li> <li>Make sure all labels are in place and are legible.</li> <li>Ensure that the <i>Operation Manual</i> and <i>Maintenance Manual</i> are sound, easy to read and stored in the storage compartment on the platform.</li> </ul>

## BODILY INJURY HAZARDS

Always follow all operation and maintenance requirements in this manual and the Maintenance Manual.

 <b>WARNING</b>	
<b>BODILY INJURY HAZARDS</b>	
	<ul style="list-style-type: none"> <li>Do not operate the machine when there are oil spills/leaks. Oil spills or leaks in hydraulic fluids may penetrate and burn the skin.</li> <li>Always operate the machine in well ventilated atmosphere to prevent carbon monoxide poisoning.</li> </ul>

**NOTE:** The operator must carry out maintenance during the pre-operation inspection only. During operation, keep the left and right doors of the chassis closed and locked. Only trained service personnel can open the left and right doors to repair the machine.

## BATTERY HAZARDS

 WARNING

## FIRE AND EXPLOSION HAZARD



- Batteries contain sulfuric acid and may generate explosive mixtures of hydrogen and oxygen gases. Keep any device that may produce sparks or flames (- including cigarettes/smoking materials) away from the battery to prevent explosion.
- Do not touch the battery terminals or cable clips with tools that may produce sparks.
- Do not charge the battery under direct sunlight.
- The battery should be charged in a well-ventilated site.
- Should the battery overheat, deform, leak, smell or smoke during service, stop using the battery immediately and place it in an open area far away from the crowd.
- Do not throw the battery to a fire or heater.

 WARNING

## CHEMICAL BURN HAZARD



- Avoid battery acid spilling or contacting unprotected skin. Wash the skin with plenty of water and seek medical attention immediately if battery acid contacts skin.
- If the battery acid escapes, please use baking soda to neutralize the acid.

 WARNING

## ELECTROCUTION HAZARD



- Contact with hot circuit may cause serious injury or death. Be sure to wear goggles, gloves and protective clothing.
- Remove all rings, watches and other accessories.

**⚠ WARNING**

**UNSAFE OPERATION HAZARD**



- Strictly follow the manufacturer’s recommendations on how to properly use and maintain the battery.
- The battery charger can only be connected to 3-phase AC outlet, and ensure the charger works properly before charging.
- Only use the charger provided by the manufacturer.
- The battery is only applicable for the matching equipment, so do not use it otherwise.
- Only the properly trained personnel authorized by the workplace are allowed to remove the battery from the machine.
- Before replacing the battery, be sure to identify the appropriate number of personnel and the lifting method.
- The wrapping of the battery is prone to becoming damaged by pointed objects, so do not use a pointed part to collide with the battery.
- Do not place other objects or tools upon the battery to avoid short circuit.
- Always keep the battery vertically placed. If tiltedly placed, the battery acid may escape.
- Never short circuit the battery positive and negative poles.
- Do not use the battery positive and negative conversely.
- Do not connect the battery directly to a power outlet.
- Do not tap, throw or step on the battery.
- Do not immerse the battery under water, acid or alkaline solution with salt, and do not expose the battery to the rain.
- Do not tamper with battery system to avoid serious accident.
- Cut off the battery main switch if the battery is not to be used for an extended period.

**⚠ WARNING**

**UNSAFE OPERATION HAZARD**

- The waste battery may pose danger, so do not discard at will. If it needs to be scrapped, contact a battery recycling company.
- Except for the professionals, do not perform a systematic maintenance or service to the battery, otherwise it may cause bodily injuries or damage to the battery system.
- Except for the professionals, do not tamper with the settings or service a signal light when the system is running, otherwise it may cause bodily injuries or damage to the battery system.
- Except for the professionals, do not remove the battery housing, otherwise it may cause damage to the battery system.

**NOTICE**

*It will not covered by the warranty if the battery attenuates or fails due to customer’s overuse (- continued use after battery level less than 10%) or failure to charge the battery for a long time (not timely charged for 3 days or longer when the battery level less than 10%).*

## HYDRAULIC HAZARDS

### WARNING

#### BURN AND SPRAY HAZARDS



- When the hydraulic system is hot, do not touch to avoid severe skin burn.



- After the machine shutdown, thoroughly clean the spilled hydraulic oil. Do not throw the oil on the ground. Once the maintenance and repair is complete, immediately clean any oil on the skin, Dispose of the used oil as per the governing laws and regulations.
- Do not use your hand to block the hydraulic leaks. If the leakage occurs, please first release the system pressure and maintain only after the hydraulic oil cools down. If any injury is caused by the spray of hydraulic oil, go to the doctor immediately, otherwise severe complication may develop.

### WARNING

#### WELDING HAZARDS



- Comply with the welder manufacturer's recommendations for procedures concerning proper use of the welder.
- Welding leads or cables may only be connected after turning off the power unit.
- Carry out welding operations only after the welding cable has been correctly connected.
- Do not use the machine as a ground wire during welding operation.
- At all times, make sure that the power tools are completely stored in the working platform. Do not hang the power tools on the railing of the working platform or the work area outside the working platform, or hang the power tools directly by the wire.

Before performing welding, grinding and polishing work, welders must seek permission of the responsible department at the workplace.

## WELDING AND POLISHING REQUIREMENTS

Before welding, grinding and polishing operations, always ensure you read and understand all operation and maintenance requirements in the *Operation Manual* and the *Maintenance Manual*.

## AFTER USING THE MACHINE

1. Choose a safe parking location that is on sturdy, level ground and that is free of obstructions. Avoid areas with heavy traffic.
2. Lower the boom to stowed position.
3. Take off all loads from the platform.
4. Push in the emergency stop button at the platform controls to the OFF position.
5. Close the cover of platform controls to protect the control panel, handle and controller from hostile weather conditions.
6. Push in the emergency stop button at ground controls to the OFF position.
7. Turn the key switch at the ground controls to OFF position and remove the key to avoid unauthorized operation of the machine.
8. Turn off the main power switch.

### **NOTICE**

*After using the machine, the power off switch must be disconnected.*

**This Page Intentionally Left Blank**

# 2 SPECIFICATIONS

## MACHINE SPECIFICATIONS

Table 2-1 TB24E Plus specifications

ITEMS	TB24E Plus (METRIC)	TB800E Plus (IMPERIAL)
<b>DIMENSION</b>		
Max platform height	24.4m	80ft 0.6in
Max working height	26.4m	86ft 7in
Max horizontal reach (restricted/ unrestricted)	19.18m/21.5m	62ft 11in/70ft 6in
Overall length (stowed)	11.55m	37ft 11in
Overall width (stowed)	2.49m	8ft 2in
Overall height (stowed)	2.88m	9ft 5in
Wheelbase	3m	9ft 10in
Ground clearance	0.36m	1ft 2in
Tire size (spec/type)	Options 385/65-22.5 (foam-filled) 385/65-24/10.00 (solid)	
Platform dimension (L×W×H)	Options 1.45×0.85×1.1 m 1.83×0.85×1.1 m 2.44×0.91×1.1 m	Options 4ft 9in×2ft 9in×3ft 7in 6ft×2ft 9in×3ft 7in 8ft×3ft×3ft 7in
<b>PERFORMANCE</b>		
Rated platform capacity (restricted)	454 kg (3 people & tools)	1000lb (3 people & tools)
Rated platform capacity (unrestricted)	300 kg (2 people & tools)	661 lb (2 people & tools)
Turntable rotation/continuity	360°/continuous	
Platform rotation	160°	
Max drive speed (stowed)	4.8km/h	3mph
Max drive speed (raised)	1.1km/h	0.68mph
Drive mode (drive×steer)	4WD×2WS	
Gradeability	45%/24°	
Turntable tailswing	1.45m	4ft 9in
Max allowable inclination	5°	
Turning radius (inside)	3.65m	12ft
Turning radius (outside)	6.91m	22ft 8in

ITEMS	TB24E Plus (METRIC)	TB800E Plus (IMPERIAL)
Max allowable side force (restricted/unrestricted)	600N/400N	135 lbf/90 lbf
Max operating noise level	79dB	
IP rating	IP65	
<b>POWER</b>		
Hybrid motor (voltage/power)	53V AC/15 kW	
Hydraulic tank capacity	170L	37.4gal (UK)/44.9gal (US)
Hydraulic system pressure	21MPa	3045Psi
Battery (number×voltage, capacity)	2×40V, 480Ah (lead-acid battery) 2×40V, 500Ah (lithium battery)	
Power system voltage	80V DC	
Control system voltage	12V DC	
Charger (input voltage/output current)	100-400V AC/40A (80A)	
<b>GROUND BEARING DATA</b>		
Max tire load	9620kg	21208 lb
Pressure against ground	730kPa	105.9Psi
<b>ENVIRONMENT</b>		
Max allowable wind speed	12.5 m/s	28 mph
Max allowable altitude	1000 m	3280ft
Allowable ambient temperature (lead-acid battery)	-10°C ~ 40°C	14°F ~ 104°F
Allowable ambient temperature (-lithium battery)	-20°C ~ 40°C	-4°F ~ 104°F
Max allowable RH	90%	
Storage environment	Stored at -20°C to 50°C (-4°F to 122°F) in a well-ventilated environment with 90% relative humidity (20°C [68°F]), and away from rain, sun, corrosive gas, inflammables and explosives.	
<b>WEIGHT</b>		
Gross weight (unladen)	17589kg	38777 lb

**Table 2-2 TB26EJ Plus specifications**

ITEMS	TB26EJ Plus (METRIC)	TB860EJ Plus (IMPERIAL)
<b>DIMENSION</b>		
Max platform height	26.3m	86ft 3in
Max working height	28.3m	92ft 10in
Max horizontal reach (restricted/unrestricted)	18.65m/20.6m	61ft 2in/67ft 7in

ITEMS	TB26EJ Plus (METRIC)	TB860EJ Plus (IMPERIAL)
Overall length (stowed)	12.5m	41ft
Overall width (stowed)	2.49m	8ft 2in
Overall height (stowed)	2.88m	9ft 5in
Wheelbase	3m	9ft 10in
Ground clearance	0.36m	1ft 2in
Tire size (spec/type)	Options 385/65-22.5 (foam-filled) 385/65-24/10.00 (solid)	
Platform dimension (L×W×H)	Options 1.45×0.85×1.1 m 1.83×0.85×1.1 m 2.44×0.91×1.1 m	Options 4ft 9in×2ft 9in×3ft 7in 6ft×2ft 9in×3ft 7in 8ft×3ft×3ft 7in
PERFORMANCE		
Rated platform capacity (restricted)	454 kg (3 people & tools)	1000lb (3 people & tools)
Rated platform capacity (unrestricted)	300 kg (2 people & tools)	661 lb (2 people & tools)
Turntable rotation/continuity	360°/continuous	
Platform rotation	160°	
Max drive speed (stowed)	4.8km/h	3 mph
Max drive speed (raised)	1.1km/h	0.68 mph
Drive mode (drive×steer)	4WD×2WS	
Gradeability	45%/24°	
Turntable tailswing	1.45m	4ft 9in
Max allowable inclination	5°	
Turning radius (inside)	3.65m	12 ft
Turning radius (outside)	6.91m	22ft 8in
Max allowable side force (restricted/unrestricted)	600N/400N	135 lbf/90 lbf
Max operating noise level	79dB	
IP rating	IP65	
POWER		
Hybrid motor (voltage/power)	53V AC/15 kW	
Hydraulic tank capacity	170L	37.4gal (UK)/44.9gal (US)
Hydraulic system pressure	21MPa	3045Psi
Battery (number×voltage, capacity)	2×40V, 480Ah (lead-acid battery) 2×40V, 500Ah (lithium battery)	
Power system voltage	80V DC	

ITEMS	TB26EJ Plus (METRIC)	TB860EJ Plus (IMPERIAL)
Control system voltage	12V DC	
Charger (input voltage/output current)	100-400V AC/40A (80A)	
<b>GROUND BEARING DATA</b>		
Max tire load	9620kg	21208 lb
Pressure against ground	730kPa	105.9 Psi
<b>ENVIRONMENT</b>		
Max allowable wind speed	12.5 m/s	28 mph
Max allowable altitude	1000 m	3280 ft
Allowable ambient temperature (lead-acid battery)	-10°C ~ 40°C	14°F ~ 104°F
Allowable ambient temperature (-lithium battery)	-20°C ~ 40°C	-4°F ~ 104°F
Max allowable RH	90%	
Storage environment	Stored at -20°C to 50°C (-4°F to 122°F) in a well-ventilated environment with 90% relative humidity (20°C [68°F]), and away from rain, sun, corrosive gas, inflammables and explosives.	
<b>WEIGHT</b>		
Gross weight (unladen)	18059kg	39813lb

**Table 2-3 TB26E Plus specifications**

ITEMS	TB26E Plus (METRIC)	TB850E Plus (IMPERIAL)
<b>DIMENSION</b>		
Max platform height	25.8m	84ft 8in
Max working height	27.8m	91ft 2in
Max horizontal reach (restricted/unrestricted)	18.65m/20.6m	61ft 2in/67ft 7in
Overall length (stowed)	11.55m	37ft 11in
Overall width (stowed)	2.49m	8ft 2in
Overall height (stowed)	2.88m	9ft 5in
Wheelbase	3m	9ft 10in
Ground clearance	0.36m	1ft 2in
Tire size (spec/type)	Options 385/65-22.5 (foam-filled) 385/65-24/10.00 (solid)	
Platform dimension (L×W×H)	Options 1.45×0.85×1.1 m 1.83×0.85×1.1 m 2.44×0.91×1.1 m	Options 4ft 9in×2ft 9in×3ft 7in 6ft×2ft 9in×3ft 7in 8ft×3ft×3ft 7in

ITEMS	TB26E Plus (METRIC)	TB850E Plus (IMPERIAL)
<b>PERFORMANCE</b>		
Rated platform capacity (restricted)	454 kg (3 people & tools)	1000lb (3 people & tools)
Rated platform capacity (unrestricted)	300 kg (2 people & tools)	661 lb (2 people & tools)
Turntable rotation/continuity	360°/continuous	
Platform rotation	160°	
Max drive speed (stowed)	4.8km/h	3mph
Max drive speed (raised)	1.1km/h	0.68mph
Drive mode (drive×steer)	4WD×2WS	
Gradeability	45%/24°	
Turntable tailswing	1.45m	4ft 9in
Max allowable inclination	5°	
Turning radius (inside)	3.65m	12ft
Turning radius (outside)	6.91m	22ft 8in
Max allowable side force (restricted/unrestricted)	600N/400N	135 lbf/90 lbf
Max operating noise level	79dB	
IP rating	IP65	
<b>POWER</b>		
Hybrid motor (voltage/power)	53V AC/15 kW	
Hydraulic tank capacity	170L	37.4gal (UK)/44.9gal (US)
Hydraulic system pressure	21MPa	3045Psi
Battery (number×voltage, capacity)	2×40V, 480Ah (lead-acid battery) 2×40V, 500Ah (lithium battery)	
Power system voltage	80V DC	
Control system voltage	12V DC	
Charger (input voltage/output current)	100-400V AC/40A (80A)	
<b>GROUND BEARING DATA</b>		
Max tire load	9620kg	21208 lb
Pressure against ground	730kPa	105.9Psi
<b>ENVIRONMENT</b>		
Max allowable wind speed	12.5 m/s	28 mph
Max allowable altitude	1000 m	3280ft
Allowable ambient temperature (lead-acid battery)	-10°C ~ 40°C	14°F ~ 104°F

ITEMS	TB26E Plus (METRIC)	TB850E Plus (IMPERIAL)
Allowable ambient temperature (-lithium battery)	-20°C ~ 40°C	-4°F ~ 104°F
Max allowable RH	90%	
Storage environment	Stored at -20°C to 50°C (-4°F to 122°F) in a well-ventilated environment with 90% relative humidity (20°C [68°F]), and away from rain, sun, corrosive gas, inflammables and explosives.	
WEIGHT		
Gross weight (unladen)	17649kg	38909lb

**Table 2-4 TB28EJ Plus specifications**

ITEMS	TB28EJ Plus (METRIC)	TB910EJ Plus (IMPERIAL)
DIMENSION		
Max platform height	27.6m	90ft 7in
Max working height	29.6m	97ft 1in
Max horizontal reach (restricted/unrestricted)	18.65m/20.6m	61ft 2in/67ft 7in
Overall length (stowed)	12.5m	41ft
Overall width (stowed)	2.49m	8ft 2in
Overall height (stowed)	2.88m	9ft 5in
Wheelbase	3m	9ft 10in
Ground clearance	0.36m	1ft 2in
Tire size (spec/type)	Options 385/65-22.5 (foam-filled) 385/65-24/10.00 (solid)	
Platform dimension (L×W×H)	Options 1.45×0.85×1.1 m 1.83×0.85×1.1 m 2.44×0.91×1.1 m	Options 4ft 9in×2ft 9in×3ft 7in 6ft×2ft 9in×3ft 7in 8ft×3ft×3ft 7in
PERFORMANCE		
Rated platform capacity (restricted)	454 kg (3 people & tools)	1000 lb (3 people & tools)
Rated platform capacity (unrestricted)	300 kg (2 people & tools)	661 lb (2 people & tools)
Turntable rotation/continuity	360°/continuous	
Platform rotation	160°	
Max drive speed (stowed)	4.8km/h	3 mph
Max drive speed (raised)	1.1km/h	0.68 mph
Drive mode (drive×steer)	4WD×2WS	
Gradeability	45%/24°	

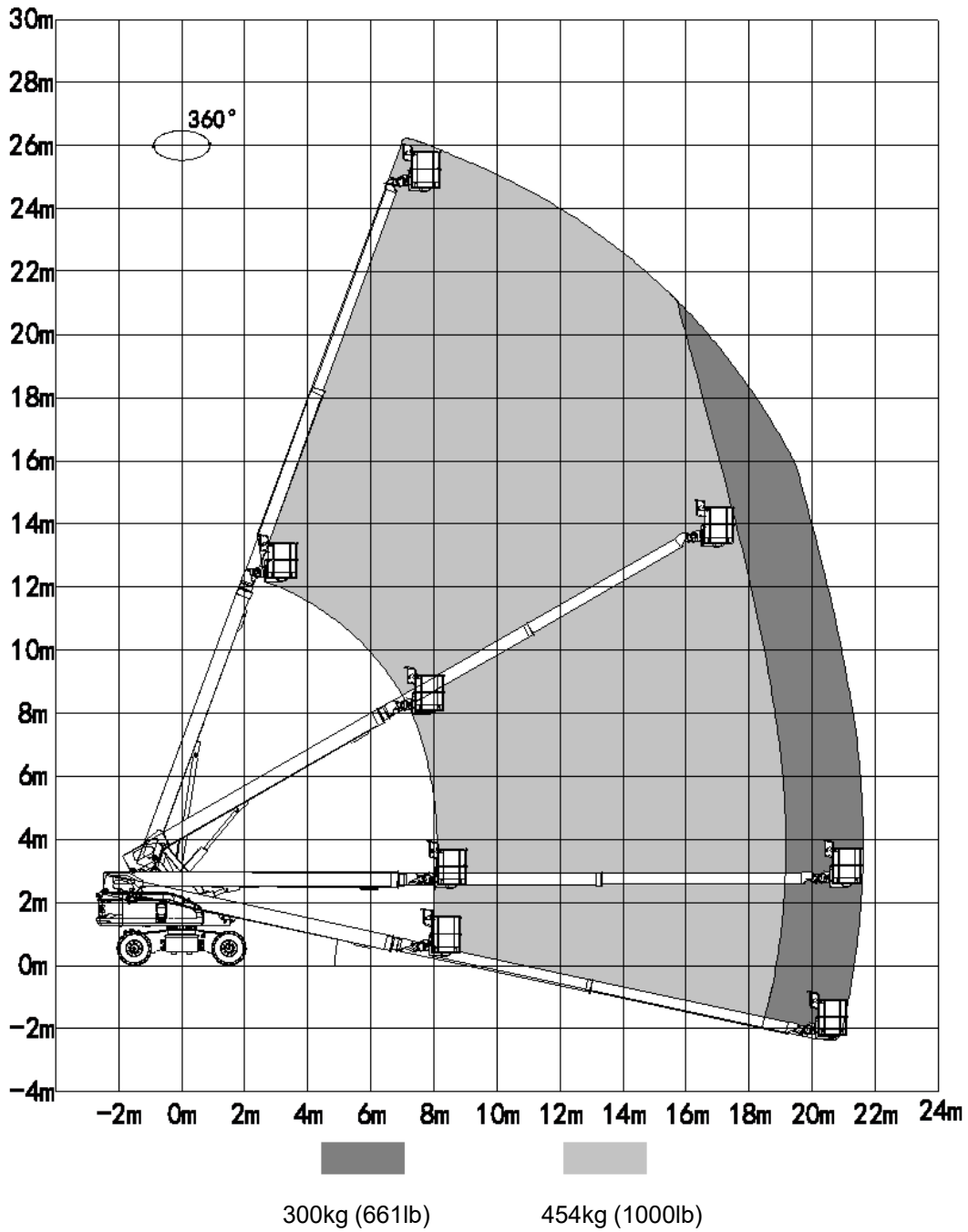
ITEMS	TB28EJ Plus (METRIC)	TB910EJ Plus (IMPERIAL)
Turntable tailswing	1.45m	4ft 9in
Max allowable inclination	5°	
Turning radius (inside)	3.65m	12 ft
Turning radius (outside)	6.91m	22ft 8in
Max allowable side force (restricted/unrestricted)	600N/400N	135 lbf/90 lbf
Max operating noise level	79dB	
IP rating	IP65	
POWER		
Hybrid motor (voltage/power)	53V AC/15 kW	
Hydraulic tank capacity	170L	37.4gal (UK)/44.9gal (US)
Hydraulic system pressure	21MPa	3045Psi
Battery (number×voltage, capacity)	2×40V, 480Ah (lead-acid battery) 2×40V, 500Ah (lithium battery)	
Power system voltage	80V DC	
Control system voltage	12V DC	
Charger (input voltage/output current)	100-400V AC/40A (80A)	
GROUND BEARING DATA		
Max tire load	9620kg	21208 lb
Pressure against ground	730kPa	105.9 Psi
ENVIRONMENT		
Max allowable wind speed	12.5 m/s	28 mph
Max allowable altitude	1000 m	3280ft
Allowable ambient temperature (lead-acid battery)	-10°C ~ 40°C	14°F ~ 104°F
Allowable ambient temperature (-lithium battery)	-20°C ~ 40°C	-4°F ~ 104°F
Max allowable RH	90%	
Storage environment	Stored at -20°C to 50°C (-4°F to 122°F) in a well-ventilated environment with 90% relative humidity (20°C [68°F]), and away from rain, sun, corrosive gas, inflammables and explosives.	
WEIGHT		

ITEMS	TB28EJ Plus (METRIC)	TB910EJ Plus (IMPERIAL)
Gross weight (unladen)	18119kg	399461lb

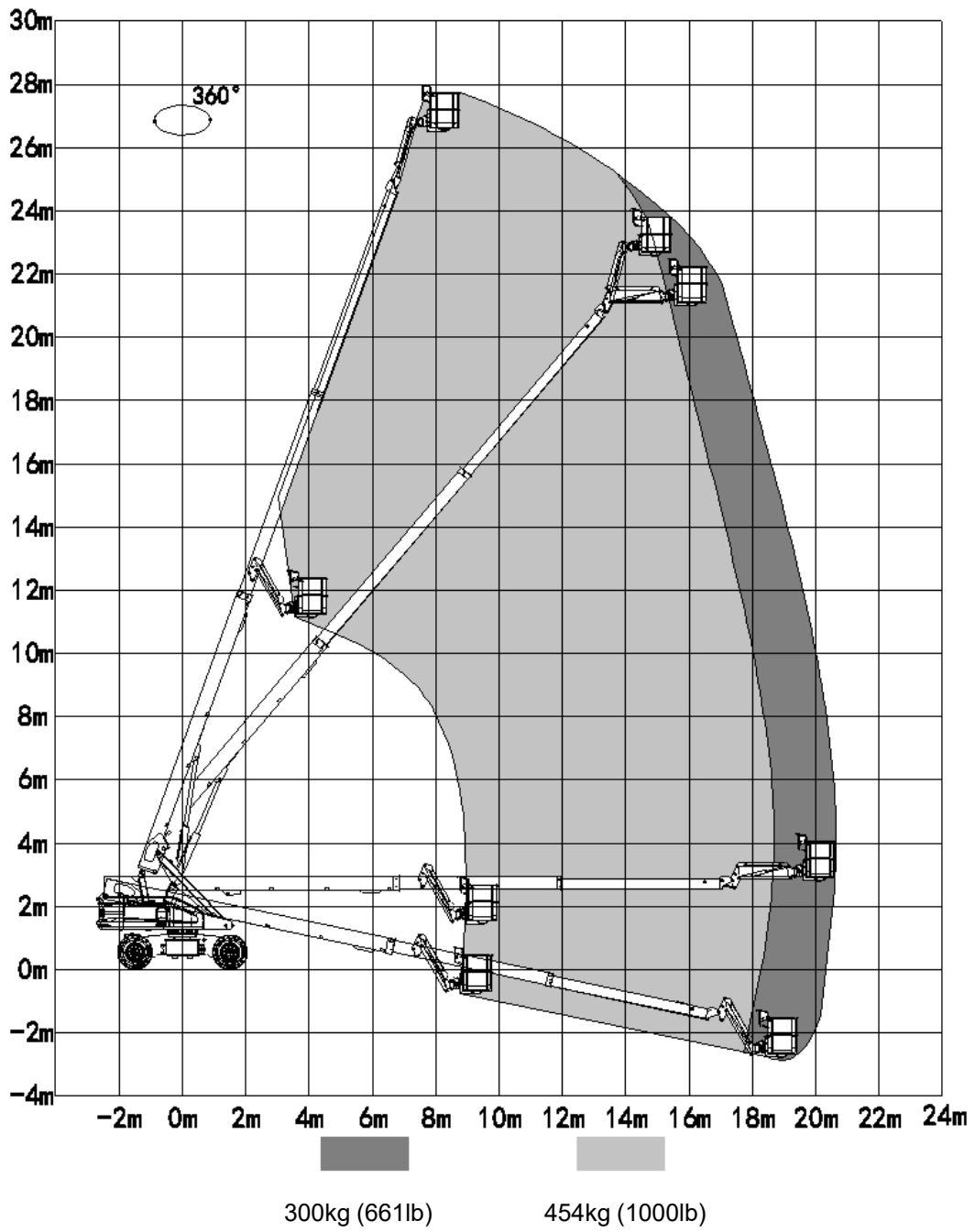
**Note:**

- a) The platform height plus the operator height (taken as 2m [6ft 7in]) is the working height.
- b) The ground bearing data is approximate, not factoring different options, thus it's only applicable in adequately safe conditions.
- c) In different areas, hydraulic oil, engine oil, coolant, fuel and lubricant should be added in accordance with the environmental temperature.
- d) In cold weather, auxiliary devices are needed to start the machines.
- e) Rated platform capacity refers to the rated load of the platform, including the loads of persons, materials, tools, platform accessories and other objects borne by the platform.
- f) The total vibration value of the platform does not exceed  $2.5\text{m/s}^2$ , and the maximum root-mean-square value of the weighted acceleration of the entire machine does not exceed  $0.5\text{m/s}^2$ .

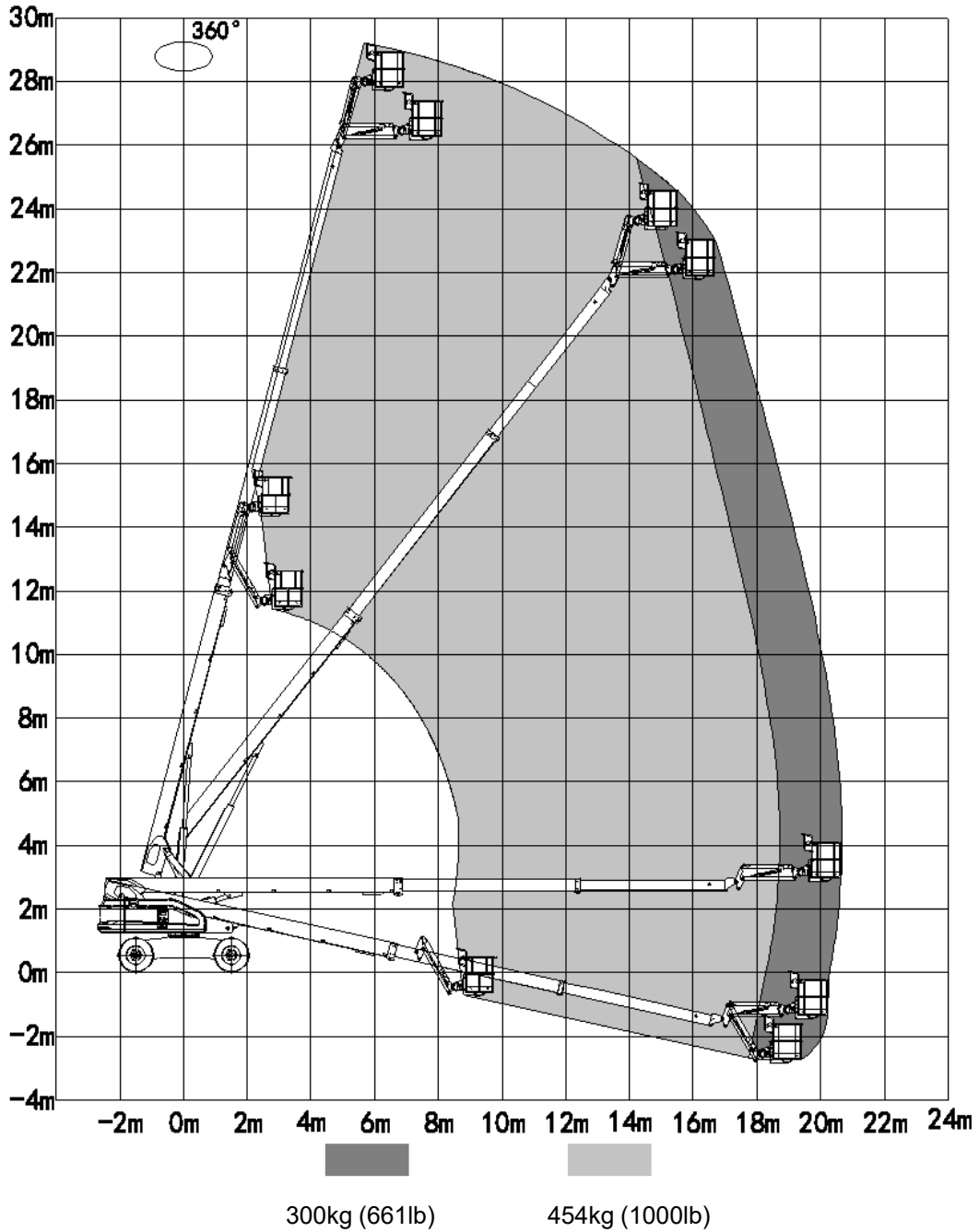
TB24E Plus chart of working envelope (5°)



TB26EJ Plus chart of working envelope (5°)



TB28EJ Plus chart of working envelope (5°)



MOTOR SPECIFICATIONS

Table 2-5 Hybrid motor

Power	15kW
Voltage	53V
Torque	55Nm
RPM	2600rpm

Frequency	88.3Hz
Current	226A

Table 2-6 Drive motor

Power	3kW
Voltage	53V
RPM	3520rpm

Frequency	120.2Hz
Current	46A

## FUNCTION SPEED

Table 2-7

ITEM	TB24E Plus & 26E Plus	TB26EJ Plus & 28EJ Plus
Boom up	95 ~ 110s	95 ~ 110s
Boom down	85 ~ 100s	85 ~ 100s
Turntable rotate (360°)-stowed	95 ~ 103s	95 ~ 103s
Turntable rotate (360°)-boom fully extended	210 ~ 250s	210 ~ 250s
Boom extend	80 ~ 90s	80 ~ 90s
Boom retract	70 ~ 80s	70 ~ 80s
Platform rotate (160°)	18 ~ 22s	18 ~ 22s
Platform level up	50 ~ 60s	50 ~ 60s
Platform level down	40 ~ 50s	40 ~ 50s
Jib up	\	32 ~ 38s
Jib down	\	22 ~ 28s
Max drive speed (30m) -stowed	20 ~ 25s	20 ~ 25s
Max drive speed (30m) -operating	88 ~ 108s	88 ~ 108s

- a) The function speed depends on the start and end point of the movement rather than the controls/ switches.
- b) The test results of drive speed vary with tires of different specifications.
- c) All the speed tests should be conducted from the platform controller. The test results will differ if testing from the ground controller.
- d) All the tests should be conducted with the hydraulic oil temperature between 50–60°C. If the hydraulic oil temperature is too low, the test results will be affected.

### Test requirements:

**Boom up/down:** With the boom fully retracted, raise and lower the boom through two full cycles.

**Turntable rotate:** With the boom centered, rotate the turntable through two full cycles.

**Boom extend/retract:** With the boom fully raised, extend and retract the boom through two full cycles.

**Platform rotate :** With the platform horizontal, rotate left and right the platform through two full cycles.

**Jib up/down:** With the platform horizontal, raise and lower the jib boom through two full cycles.

**Drive-stowed:** With the machine on level surface, switch to drive high speed, fully stroke the drive control handle to drive forward and reverse for 30m respectively. Test twice.

**Drive-operating:** With the machine on level surface, fully stroke the drive control handle to drive forward and reverse for 30m respectively. Test twice.

## WEIGHT OF MAJOR COMPONENTS

**WARNING**

UNSAFE OPERATION HAZARD

- Do not move heavy components without mechanical assistance.
- Do not place heavy components upon instable surfaces.

Table 2-8

Component	Metric (kg)	Imperial (lb)
Chassis assembly	6318	13931
Turntable assembly	7514	16568

Component	Metric (kg)	Imperial (lb)
Boom assembly (TB24E Plus)	3326	7334
Boom assembly (TB26EJ Plus)	3497	7711
Boom assembly (TB26E Plus)	3316	7312
Boom assembly (TB28EJ Plus)	3552	7832
Base boom	889	1960
1st telescopic boom	465	1025
2nd telescopic boom	308	679
Jib boom assembly (TB26EJ&28EJ Plus)	161	355
Cable track	139	306
Telescoping mechanism	397	875
Platform	187	412
Power unit	20	44
Hybrid motor	66	146
Counterweight (turntable)	4898	10798
Slewing mechanism	367	809
Main boom telescope cylinder	316	697
Main boom level cylinder, upper	39	86
Main boom level cylinder, lower	37	82
Main boom lift cylinder	373	822
Jib boom cylinder (TB26EJ&28EJ Plus)	34	75
Platform rotator	40	88
Drive motor	43	95
Drive reducer	120	265
Wheel assembly	315	695
Battery (lead-acid)	655	1444
Battery (lithium)	240	529
Counterweight (inside battery box)- lithium battery only	433	955
Note: The weight of components may vary with different options selected.		

## HYDRAULIC SYSTEM SPECIFICATIONS

Table 2-9

ITEM	SPECIFICATION
<b>Hydraulic Oil</b>	
Normal temperature region (0°C~40°C [32°F~104°F])	L-HM46
Cold region (-25°C~25°C [-13°F~77°F])	L-HV32
High temperature region (> 40°C [104°F])	L-HM68
Extremely cold region (< -30°C [-22°F])	Special program to be determined
<b>Hydraulic Pump</b>	
Type	Open-circuit variable displacement pump
Displacement	45.9cc/r
Rated operating pressure	32 MPa (4640 Psi)
<b>Function Manifold</b>	
Boom function manifold pressure	21MPa (3045 Psi)

## HYDRAULIC HOSE AND FITTING SPECIFICATIONS

### HYDRAULIC HOSE TORQUE

Hydraulic hoses must be torqued to the following specifications.

Table 2-10 Hydraulic Hose Torque

METRIC THREAD	L (LIGHT-DUTY)	S (HEAVY-DUTY)
M12 × 1.5	19 ± 1 Nm (14 ± 1 ft-lb)	
M14 × 1.5	26 ± 2 Nm (19 ± 2 ft-lb)	
M16 × 1.5	40 ± 3 Nm (30 ± 2 ft-lb)	
M18 × 1.5	50 ± 4 Nm (37 ± 3 ft-lb)	
M20 × 1.5	-	60 ± 4 Nm (44 ± 3 ft-lb)
M22 × 1.5	70 ± 5 Nm (52 ± 4 ft-lb)	-
M24 × 1.5	-	85 ± 6 Nm (63 ± 4 ft-lb)
M26 × 1.5	90 ± 6 Nm (66 ± 4 ft-lb)	-

METRIC THREAD	L (LIGHT-DUTY)	S (HEAVY-DUTY)
M30 × 2	120 ± 8 Nm (89 ± 6 ft-lb)	140 ± 10 Nm (103 ± 7 ft-lb)
M36 × 2	150 ± 12 Nm (111 ± 9 ft-lb)	180 ± 12 Nm (133 ± 9 ft-lb)
M42 × 2	-	260 ± 16 Nm (192 ± 12 ft-lb)
M45 × 2	240 ± 15 Nm (177 ± 11 ft-lb)	-
M52 × 2	250 ± 16 Nm (184 ± 12 ft-lb)	280 ± 18 Nm(207 ± 13 ft-lb )

**HYDRAULIC FITTING TORQUE**

Hydraulic fittings with metric thread must be torqued to the following specifications.

**Table 2-11 Hydraulic Fitting Torque – Metric**

THREAD SIZE	INSTALLED INTO ALUMINUM	INSTALLED INTO STEEL	
	ED, O-RING + CIRCLIP	ED, O-RING + CIRCLIP	O-RING
<b>L (LIGHT-DUTY)</b>			
M10×1	18 ± 1 Nm(13 ± 1 ft-lb )	20 ± 2 Nm (15 ± 2 ft-lb)	18 ± 1 Nm (13 ± 1 ft-lb)
M12×1.5	30 ± 2 Nm (22 ± 2 ft-lb)	35 ± 2 Nm (26 ± 2 ft-lb)	30 ± 2 Nm (22 ± 2 ft-lb )
M14×1.5	42 ± 3 Nm (31 ± 2 ft-lb)	48 ± 4 Nm (35 ± 3 ft-lb )	35 ± 2 Nm (26 ± 2 ft-lb)
M16×1.5	55 ± 4 Nm (41 ± 3 ft-lb)	60 ± 4 Nm (44 ± 3 ft-lb)	40 ± 3 Nm (30 ± 3 ft-lb)
M18×1.5	75 ± 5 Nm (55 ± 4 ft-lb)	75 ± 5 Nm (55 ± 4 ft-lb)	45 ± 3 Nm (33 ± 4 ft-lb)
M22×1.5	90 ± 6 Nm (66 ± 4 ft-lb)	130 ± 8 Nm (96 ± 6 ft-lb)	60 ± 4 Nm(44 ± 3 ft-lb )
M27×2	120 ± 8 Nm (89 ± 6 ft-lb)	185 ± 12 Nm (136 ± 9 ft-lb)	100 ± 7 Nm (74 ± 5 ft-lb)
M30×2	140 ± 8 Nm (103 ± 6 ft-lb)	245 ± 15 Nm (181 ± 11 ft-lb)	135 ± 8 Nm (100 ± 6 ft-lb)
M33×2	180 ± 10 Nm (133 ± 7 ft-lb)	320 ± 20 Nm (236 ± 15 ft-lb)	160 ± 10 Nm(118 ± 7 ft-lb )
M42×2	240 ± 15 Nm (177 ± 11 ft-lb)	450 ± 25 Nm (332 ± 18 ft-lb)	210 ± 13 Nm (155 ± 10 ft-lb)
M48×2	280 ± 20 Nm (207 ± 15 ft-lb)	540 ± 30 Nm (398 ± 22 ft-lb)	260 ± 15 Nm (192 ± 11 ft-lb)
<b>S (HEAVY-DUTY)</b>			
M12×1.5	33 ± 2 Nm (24 ± 2 ft-lb)	43 ± 3 Nm (32 ± 2 ft-lb)	35 ± 2 Nm (26 ± 2 ft-lb)
M14×1.5	42 ± 3 Nm (31 ± 2 ft-lb)	50 ± 4 Nm (37 ± 3 ft-lb)	45 ± 3 Nm (33 ± 2 ft-lb)
M16×1.5	55 ± 4 Nm (41 ± 3 ft-lb)	75 ± 5 Nm (55 ± 4 ft-lb)	55 ± 4 Nm (41 ± 3 ft-lb)
M18×1.5	75 ± 5 Nm (55 ± 4 ft-lb)	95 ± 6 Nm (70 ± 4 ft-lb)	70 ± 5 Nm (52 ± 4 ft-lb)
M22×1.5	90 ± 6 Nm (66 ± 4 ft-lb)	140 ± 8 Nm(103 ± 6 ft-lb )	100 ± 10 Nm (74 ± 7 ft-lb)
M27×2	120 ± 8 Nm (89 ± 6 ft-lb)	185 ± 12 Nm (136 ± 9 ft-lb)	160 ± 10 Nm (118 ± 7 ft-lb)
M30×2	140 ± 8 Nm (103 ± 6 ft-lb)	245 ± 15 Nm (181 ± 11 ft-lb)	210 ± 13 Nm (155 ± 10 ft-lb)
M33×2	180 ± 10 Nm (133 ± 7 ft-lb)	320 ± 20 Nm (236 ± 15 ft-lb)	260 ± 15 Nm (192 ± 11 ft-lb)

THREAD SIZE	INSTALLED INTO ALUMINUM	INSTALLED INTO STEEL	
	ED, O-RING + CIRCLIP	ED, O-RING + CIRCLIP	O-RING
M42×2	240 ± 15 Nm (177 ± 11 ft-lb)	450 ± 25 Nm (332 ± 18 ft-lb)	330 ± 20 Nm (243 ± 15 ft-lb)
M48×2	280 ± 20 Nm (207 ± 15 ft-lb)	540 ± 30 Nm (398 ± 22 ft-lb)	420 ± 25 Nm (310 ± 18 ft-lb)

Hydraulic fittings with British Standard Pipe (BSP) thread) must be torqued to the following specifications.

**Table 2-12 Hydraulic Fitting Torque – British Standard Pipe (BSP)**

THREAD SIZE	INSTALLED INTO ALUMINUM	INSTALLED INTO STEEL	
	ED, O-RING + CIRCLIP	ED, O-RING + CIRCLIP	O-RING
<b>L (LIGHT-DUTY)</b>			
G1/8A	20 ± 1 Nm (15 ± 1 ft-lb)	20 ± 1 Nm (15 ± 1 ft-lb)	-
G1/4A	35 ± 2 Nm (26 ± 2 ft-lb)	40 ± 2 Nm (30 ± 2 ft-lb)	-
G3/8A	50 ± 3 Nm (37 ± 2 ft-lb)	75 ± 5 Nm (55 ± 2 ft-lb)	-
G1/2A	75 ± 5 Nm (55 ± 2 ft-lb)	95 ± 6 Nm (70 ± 4 ft-lb)	-
G3/4A	120 ± 8 Nm (89 ± 6 ft-lb)	185 ± 12 Nm (136 ± 9 ft-lb)	-
G1A	180 ± 10 Nm (133 ± 7 ft-lb)	320 ± 20 Nm (236 ± 15 ft-lb)	-
G1-1/4A	240 ± 15 Nm (177 ± 11 ft-lb)	450 ± 25 Nm (332 ± 18 ft-lb)	-
G1-1/2A	280 ± 20 Nm (207 ± 15 ft-lb)	540 ± 30 Nm (398 ± 22 ft-lb)	-
<b>S (HEAVY-DUTY)</b>			
G1/4A	40 ± 3 Nm (30 ± 2 ft-lb)	43 ± 3 Nm (32 ± 2 ft-lb)	-
G3/8A	55 ± 3 Nm (41 ± 2 ft-lb)	85 ± 5 Nm (63 ± 4 ft-lb)	-
G1/2A	80 ± 5 Nm (59 ± 4 ft-lb)	120 ± 8 Nm (89 ± 6 ft-lb)	-
G3/4A	120 ± 8 Nm (89 ± 6 ft-lb)	185 ± 12 Nm (136 ± 9 ft-lb)	-
G1A	180 ± 10 Nm (133 ± 7 ft-lb)	320 ± 20 Nm (236 ± 15 ft-lb)	-
G1-1/4A	240 ± 15 Nm (177 ± 11 ft-lb)	450 ± 25 Nm (332 ± 18 ft-lb)	-
G1-1/2A	280 ± 20 Nm (207 ± 15 ft-lb)	540 ± 30 Nm (398 ± 22 ft-lb)	-

Hydraulic fittings with Unified Thread Standard (UNC/UNF) thread must be torqued to the following specifications.

**Table 2-13 Hydraulic Fitting Torque – Unified Thread Standard (UNC/UNF)**

THREAD SIZE	INSTALLED INTO ALUMINUM	INSTALLED INTO STEEL
	O-RING	O-RING
<b>L (LIGHT-DUTY)</b>		
7/16-20	21 ± 2 Nm (15 ± 2 ft-lb)	21 ± 2 Nm (15 ± 2 ft-lb)

THREAD SIZE	INSTALLED INTO ALUMINUM	INSTALLED INTO STEEL
	O-RING	O-RING
9/16-18	34 ± 2 Nm (25 ± 2 ft-lb)	35 ± 2 Nm (26 ± 2 ft-lb)
11/16-12	40 ± 3 Nm (30 ± 2 ft-lb)	50 ± 4 Nm (37 ± 3 ft-lb)
3/4-16	50 ± 3 Nm (37 ± 2 ft-lb)	65 ± 4 Nm (48 ± 3 ft-lb)
7/8-14	75 ± 5 Nm (55 ± 4 ft-lb)	110 ± 8 Nm (81 ± 6 ft-lb)
1-1/16-12	110 ± 8 Nm (81 ± 6 ft-lb)	140 ± 10 Nm (103 ± 7 ft-lb)
1-5/16-12	160 ± 10 Nm (118 ± 7 ft-lb)	210 ± 15 Nm (155 ± 11 ft-lb)
<b>S (HEAVY-DUTY)</b>		
7/16-20	21 ± 2 Nm (15 ± 2 ft-lb)	23 ± 2 Nm (17 ± 2 ft-lb)
9/16-18	34 ± 2 Nm (25 ± 2 ft-lb)	40 ± 3 Nm (30 ± 2 ft-lb)
11/16-12	40 ± 3 Nm (30 ± 2 ft-lb)	65 ± 4 Nm (48 ± 3 ft-lb)
3/4-16	50 ± 3 Nm (37 ± 2 ft-lb)	80 ± 6 Nm (59 ± 4 ft-lb)
7/8-14	75 ± 5 Nm (55 ± 4 ft-lb)	125 ± 10 Nm (92 ± 7 ft-lb)
1-1/16-12	110 ± 8 Nm (81 ± 6 ft-lb)	185 ± 15 Nm (136 ± 11 ft-lb)
1-5/16-12	160 ± 10 Nm (118 ± 7 ft-lb)	280 ± 20 Nm (207 ± 15 ft-lb)

**HYDRAULIC HOSE AND FITTING TIGHTENING PROCEDURE**

The hydraulic hose and fitting must be installed as per the following requirements.

1. Before installation, check the seals on the hose and fitting, and replace the seal or even the hose assembly and fitting if the seal is found to be damaged or oil spills out of the seal. The seal cannot be reused if the fitting or hose end has been tightened beyond specifications.
2. If the seal is to be replaced, lubricate the seal before installation.

3. Position the hose and nut squarely on the fitting. Then tighten the nut as required.
4. Tighten the nut or fitting to the torque specified in the appropriate table.
5. After installation, perform all machine functions and inspect the hose, fittings and related components to confirm there are no leaks.

**FASTENER TORQUE SPECIFICATIONS**

Unless special torque requirements are stated in this manual or other instructions, torque metric bolts to the values listed in the table below.

**Table 2-14 Fastener Torque Specifications – Metric**

NOMINAL DIAMETER (MM)	PITCH (MM)	CLASS 8.8	CLASS 10.9	CLASS 12.9
5	0.8	7 Nm (5 ft-lb)	9 Nm (7 ft-lb)	10 Nm (7 ft-lb)
6	1	12 Nm (9 ft-lb)	15 Nm (11 ft-lb)	18 Nm (13 ft-lb)
8	1.25	30 Nm (22 ft-lb)	35 Nm (26 ft-lb)	42 Nm (31 ft-lb)

NOMINAL DIAMETER (MM)	PITCH (MM)	CLASS 8.8	CLASS 10.9	CLASS 12.9
	1	30 Nm (22 ft-lb)	37 Nm (27 ft-lb)	45 Nm (33 ft-lb)
10	1.5	55 Nm (41 ft-lb)	75 Nm (55 ft-lb)	85 Nm (63 ft-lb)
	1.25	56 Nm (41 ft-lb)	77 Nm (57 ft-lb)	87 Nm (64 ft-lb)
	1	60 Nm (44 ft-lb)	80 Nm (59 ft-lb)	92 Nm (68 ft-lb)
12	1.75	95 Nm (70 ft-lb)	125 Nm (92 ft-lb)	150 Nm (111 ft-lb)
	1.5	100 Nm (74 ft-lb)	130 Nm (96 ft-lb)	155 Nm (114 ft-lb)
	1.25	105 Nm (77 ft-lb)	135 Nm (100 ft-lb)	160 Nm (118 ft-lb)
14	2	150 Nm (110 ft-lb)	200 Nm (148 ft-lb)	230 Nm (170 ft-lb)
	1.5	165 Nm (122 ft-lb)	210 Nm (155 ft-lb)	250 Nm (184 ft-lb)
16	2	230 Nm (170 ft-lb)	300 Nm (221 ft-lb)	360 Nm (266 ft-lb)
	1.5	250 Nm (184 ft-lb)	320 Nm (236 ft-lb)	380 Nm (280 ft-lb)
18	2.5	320 Nm (236 ft-lb)	420 Nm (310 ft-lb)	500 Nm (369 ft-lb)
	1.5	360 Nm (266 ft-lb)	470 Nm (345 ft-lb)	550 Nm (406 ft-lb)
20	2.5	450 Nm (332 ft-lb)	600 Nm (443 ft-lb)	700 Nm (516 ft-lb)
	1.5	500 Nm (369 ft-lb)	650 Nm (479 ft-lb)	770 Nm (568 ft-lb)
22	2.5	600 Nm (443 ft-lb)	800 Nm (590 ft-lb)	980 Nm (723 ft-lb)
	2	650 Nm (479 ft-lb)	850 Nm (627 ft-lb)	1050 Nm (774 ft-lb)
24	3	750 Nm (553 ft-lb)	1050 Nm (774 ft-lb)	1250 Nm (923 ft-lb)
	2	800 Nm (590 ft-lb)	1100 Nm (811 ft-lb)	1300 Nm (959 ft-lb)
27	3	1150 Nm (848 ft-lb)	1500 Nm (1106 ft-lb)	1800 Nm (1327 ft-lb)
30	3.5	1500 Nm (1106 ft-lb)	2000 Nm (1475 ft-lb)	2400 Nm (1770 ft-lb)

Unless special torque requirements are listed in this manual or other instructions, torque Unified Thread Standard bolts (label: UNC) to the values listed in the table below.

**Table 2-15 Bolt Torque Specifications Unified – Thread Standard (UNC)**

NOMINAL DIAMETER (IN)	OPPOSITE NUT SIZE (S)	CLASS 5	CLASS 8
1/4-20	7/16"	10 Nm (7 ft-lb)	14 Nm (10 ft-lb)
5/16-18	1/2"	21 Nm (15 ft-lb)	29 Nm (21 ft-lb)
3/8-16	9/16"	37 Nm (27 ft-lb)	51 Nm (38 ft-lb)
7/16-14	5/8"	60 Nm (44 ft-lb)	82 Nm (60 ft-lb)
1/2-13	3/4"	90 Nm (66 ft-lb)	130 Nm (96 ft-lb)
9/16-12	13/16"	130 Nm (96 ft-lb)	180 Nm (133 ft-lb)

NOMINAL DIAMETER (IN)	OPPOSITE NUT SIZE (S)	CLASS 5	CLASS 8
5/8-11	15/16"	178 Nm (131 ft-lb)	250 Nm (184 ft-lb)
3/4-10	1-1/8"	315 Nm (232 ft-lb)	445 Nm (328 ft-lb)
7/8-9	-	509 Nm (375 ft-lb)	715 Nm (527 ft-lb)

Unless special torque requirements are listed in this manual or other instructions, torque Unified Thread Standard bolts (label: UNF) to the values listed in the table below.

**Table 2-16 Bolt Torque Specifications – Thread Standard (UNF)**

NOMINAL DIAMETER (IN)	OPPOSITE NUT SIZE (S)	CLASS 5	CLASS 8
1/4-28	7/16"	11.5 Nm (8 ft-lb)	16 Nm (11 ft-lb)
5/16-24	1/2"	23 Nm (17 ft-lb)	32 Nm (24 ft-lb)
3/8-24	9/16"	41 Nm (30 ft-lb)	58 Nm (43 ft-lb)
7/16-20	5/8"	65 Nm (48 ft-lb)	92 Nm (68 ft-lb)
1/2-20	3/4"	100 Nm (74 ft-lb)	145 Nm (107 ft-lb)
9/16-18	13/16"	145 Nm (107 ft-lb)	200 Nm (148 ft-lb)
5/8-18	15/16"	200 Nm (148 ft-lb)	280 Nm (207 ft-lb)
3/4-16	1-1/8"	350 Nm (258 ft-lb)	495 Nm (365 ft-lb)
7/8-14	-	560 Nm (413 ft-lb)	780 Nm (575 ft-lb)

**This Page Intentionally Left Blank**

# 3 SYSTEM DESCRIPTIONS

## POWER SOURCE

The machine is powered by a hybrid motor.

The machine uses a 12V battery to drive a 12V power unit to drive the gear pump which provides auxiliary power to the system.

## HYDRAULIC SYSTEM

The machine is driven by a hybrid motor, which drives the oil pump to provide high pressure oil. The entire hydraulic system can be divided into two parts: one for controlling boom functions and turntable rotation, and the other for controlling steer function and oscillation function.

When the motor operates, the open-circuit variable pump, the electric proportional flow valve and the solenoid directional valve on the boom function manifold work together to drive the hydraulic actuator to work. Based on different flow requirements of boom action, high-pressure oils with different flow rates will be output by the electronic control system through adjusting the current of the electric proportional valve and the open-circuit variable pump through adjusting the angle of swash plate. In order to avoid excessive pressure in the hydraulic system and damage to the hydraulic components, pressure-limiting relief valves are installed in the hydraulic system. In addition, the hydraulic system is equipped with an emergency power unit, which can realize the emergency operation of the boom action.

## ELECTRICAL SYSTEM

The system adopts two 40V lead acid batteries in series or two 40V lithium battery in series to drive the drive motor and hybrid motor for controlling boom functions, turntable rotation and steer functions, and provide 12V control power for the whole machine through a DC converter.

A 12V maintenance-free storage battery is used in the system to provide emergency power supply for the whole machine.

All storage batteries are charged through external power supply and use the same charger. A power-off switch is fitted to protect the control system.

## MACHINE CONTROL

The machine functions are controlled by two controllers, one installed on the left side of turntable to control the turntable rotation and boom functions, the other on the platform to control the machine drive, turntable rotation and boom functions. The controller communicates signals through a high-speed data bus.

## SAFETY MEASURES

A wide range of sensors and limit switches are used to provide signals for the controller.

- The level sensor measures the inclinations in X axis and Y axis of the chassis. When the inclined angle in X or Y axis exceeds 5°, the alarm will go off and restrict such functions as lift, drive and steer. For more information, please reference [B-10 Inspect Tilt Protection, page 5-16](#).
- The length sensor measures the boom extended length. When the boom extended length exceeds the maximum allowable horizontal reach, the boom is restricted from continuing extending. For more information, please reference [B-9 Inspect Length and Angle Sensors, page 5-15](#).
- The angle sensor measures the boom lift angle. When the boom lift angle exceeds the limits, the boom is restricted from continuing lifting/lowering. For more information, please reference [B-9 Inspect Length and Angle Sensors, page 5-15](#).
- The weight sensor measures the weight on the platform. When the weight on the platform exceeds the rated load, the associated functions will be restricted. For more information, please reference [C-3 Inspect Weighing System, page 5-22](#).

**This Page Intentionally Left Blank**

# 4 SERVICE AND GUIDELINES

## MACHINE PREPARATION, INSPECTION AND MAINTENANCE

### GENERAL

This section provides safety and necessary information for the machine operators. For maximum service life and safe operation, ensure that all necessary inspections and maintenance have been completed before placing the machine into service.

#### Machine positions

##### Stowed position:

Boom descends and retracts in place.

##### Non-operating position:

Boom rises at an angle not exceeding 15°, and extends not exceeding 1.2m (3.9 ft).

##### Operating/raised position:

Boom rises at an angle exceeding 15°, or extends beyond 1.2m (3.9 ft).

## PREPARATION, INSPECTION AND MAINTENANCE

It is important to establish and conform to a comprehensive inspection and preventive maintenance program. This manual outlines the scheduled machine inspections and maintenance recommended by Hunan Sinoboom Intelligent Co., Ltd., Consult your national, regional or local regulations for aerial work platforms. The frequency of inspections and maintenance must be increased as environment, severity and frequency of usage requires.

## QUALIFIED SINOBOOM EQUIPMENT MECHANIC

Qualified Sinoboom equipment mechanic is a person recognized by Sinoboom as one who, by possession of a recognized degree, certificate, training, has successfully demonstrated the ability and proficiency to service, repair and maintain the subject Sinoboom product model.

## PRE-OPERATION INSPECTION

Prior to daily use or work shift of operators, the user or operator should perform a pre-operation inspection. Refer to the *Operation Manual* for the complete procedure for the pre-operation inspection. The *Operation Manual* must be entirely read and understood before performing the pre-operation inspection.

## PRE-DELIVERY INSPECTION AND FREQUENT INSPECTION

The pre-delivery inspection shall be performed by qualified Sinoboom equipment mechanic. The pre-delivery inspection and the frequent inspection are performed in the same manner, but at different times. The pre-delivery inspection shall be performed before each sale, lease or rental delivery. The frequent inspection shall be accomplished for each machine in service for 3 months or 150 hours (whichever comes first); out of service for a period of more than 3 months; or when purchased used. The frequency of this inspection must be increased as environment, severity and frequency of usage requires.

Reference the *Prepare the Work Record before Delivery* and *Repair & Inspection Report* for items requiring inspection. Reference the *Inspection Procedures* in appropriate areas of this manual to perform the inspection and maintenance procedures.

## ANNUAL MACHINE INSPECTION

The annual machine inspection must be performed on an annual basis, no later than 13 months from the date of the prior annual machine inspection. Hunan Sinoboom Intelligent Equipment Co., Ltd. recommends this task be performed by a factory-trained service technician, a person recognized by Sinoboom as one who, by possession of a recognized degree, certificate, training, has successfully demonstrated the ability and proficiency to service, repair and maintain the subject Sinoboom product model.

Reference the *Repair & Inspection Report* for items requiring inspection. Reference the *Inspection Procedures* in appropriate areas of this manual to perform the inspection and maintenance procedures.

For the purpose of receiving the safety-related bulletins, it is important that Hunan Sinoboom Intelligent Equipment Co., Ltd. has updated ownership information for each machine. When performing each

annual machine inspection, notify Hunan Sinoboom Intelligent Equipment Co., Ltd. of the current machine ownership information.

### PREVENTIVE MAINTENANCE

The preventive maintenance must be performed by a qualified Sinoboom equipment mechanic.

Reference the *Repair & Inspection Report* and *Maintenance Schedule* in this manual for the inspection items and intervals. Reference the *Inspection Procedures* in appropriate areas of this manual to perform the inspection and maintenance procedures.

**Table 4-1**

Type	Frequency	Primary Responsibility	Service Qualification	Reference
Pre-operation Inspection	Prior to use each day; or at each operator change.	User or operator	User or operator	Operation Manual
Pre-delivery Inspection	Prior to each sale, lease or rental delivery.	Owner, dealer or user	Qualified Sinoboom mechanic	Maintenance Manual, Pre-delivery Preparation Form, and Maintenance Inspection Report
Frequent Inspection	In service for 3 months or 150 hours, whichever comes first; or out of service for a period of more than 3 months; or purchased used.	Owner, dealer or user	Qualified Sinoboom mechanic	Maintenance Manual and Maintenance Inspection Report
Annual Machine Inspection	Annually, no later than 13 months from the date of the prior annual inspection.	Owner, dealer or user	Factory-trained service technician	Maintenance Manual, Pre-delivery Preparation Form, and Maintenance Inspection Report
Preventive Maintenance	At intervals as specified in the Maintenance Manual.	Owner, dealer or user	Qualified Sinoboom mechanic	Maintenance Manual, Maintenance Inspection Report, and Maintenance Schedule

## STORAGE

Please observe the following recommendations to ensure the best performance of cylinders and avoid corrosion due to an extended period of storage (indoor/outdoor):

- The machine should be stored in stowed position with all tires adjusted to keep aligned.
- Fully raise and lower the scissor and steer left and right the wheels twice a week to lubricate the cylinders.

## MAINTENANCE AND SERVICING PRECAUTIONS

### GENERAL

This section assists you in the use and application of the maintenance and servicing procedures contained in this manual.

## SAFETY AND WORKMANSHIP

Before servicing the machine, take the following preventive measures:

1. Cut off the power source to disable the machine and set up a sign in a readily visible place.
2. Place all controls in OFF position to prevent unintended activation of the controls.
3. Lower the platform to the lowest position if possible, or at least ensure it won't fall off.
4. Before releasing or removing any hydraulic component, dissipate the hydraulic pressure in the hydraulic circuit.

If the machine is not serviced in the state as above for the sake of the particular nature of the maintenance task, it should at least observe the safety rules regarding the maintenance and repair of the machine contained in this manual and the Operation Manual.

Your safety, and that of others, is the first consideration when engaging in the maintenance of equipment. Never attempt to move heavy parts without the aid of a mechanical device. Do not allow heavy objects to rest in an unstable position. When raising a portion of the equipment, ensure that adequate support is provided.

## CLEANLINESS

1. The most important single item in preserving the service life of a machine is to keep dirt and foreign materials out of the vital components. Precautions have been taken to safeguard against this. Shields, covers, seals and filters are provided to keep air, fuel and oil supplies clean; however, these items must be maintained on a scheduled basis to function properly.
2. When air, fuel or oil lines are disconnected, clean the adjacent areas as well as the openings and fittings. As soon as a component or line is disconnected, cap or cover all openings to prevent entry of foreign matter.
3. Clean and inspect all parts during servicing and maintenance, and assure that all passages and openings are unobstructed. Cover all parts to keep them clean. Be sure all parts are clean before they are installed. New parts should remain in their containers until they are ready to be used.

## COMPONENT REMOVAL AND INSTALLATION

1. Establish as per this manual a safe and reasonable program appropriate to the on-site conditions for installation of the machine.
2. The personnel engaging in disassembly and installation of this machine should be competent in the task and understand how to use the personal protection equipment in a correct manner.
3. The qualified personnel should not install the machine unless a thorough inspection of the ground for installation, the hidden foundation as well as the anchored parts is made or sufficiently evidenced to comply with the manufacturer's requirements.
4. The wind speed at the installation location should not be more than 8.3m/s.
5. Check the on-site conditions like power supply, foundation, track, etc., and install only when all are eligible.
6. All parts should be checked before installation to verify they are in good condition.
7. The high-strength bolts should be tightened as required in this manual.
8. The requirements for the reception of the on-site installed machine are as follows:
  - Conduct the required inspection and function test to confirm the machine is properly installed for the purpose of the particular application and all safety devices operate smoothly.
  - The static and dynamic load tests of the machine suggest a compliance with the relevant standard.

- The qualified personnel should sign on the handover document to evidence the integrity of the machine. All inspection/test results should be documented (including the inspector name, title, organization and date).
9. The disassembly of the machine should also follow the same safety requirements for the installation of the machine.
  10. If mechanical assistance is required for the disassembly of the machine, please choose the suitable lifting points, lifting tools, and lifting equipment according to this manual and the onsite conditions. The lifting equipment that allows adjustment is preferred. All lifting tools (chains, sling, etc.) should be parallel to each other and should better remain vertical to the top of the component being lifted.
  11. Should it be necessary to remove a component on an angle, keep in mind that the capacity of an eyebolt or similar bracket lessens, as the angle between the supporting structure and the component becomes less than 90 degrees.
  12. If a part resists removal, check to see whether all nuts, bolts, cables, brackets, wiring, etc., have been removed and that no adjacent parts are interfacing.

## COMPONENT DISASSEMBLY AND ASSEMBLY

When disassembling or reassembling a component, complete the procedural steps in sequence. Do not partially disassemble or assemble one part, then start on another. Always recheck your work to assure that nothing has been overlooked. Do not make any adjustments, other than those recommended, without obtaining proper approval.

## SCRAP OF STRUCTURAL PARTS

- When some major component fails to fulfill the safety requirements due to corrosion, wear, etc., it should be refitted or reinforced, otherwise it should be scrapped.
- When the stressed structure suffers a permanent deformation and a repair is impossible, it should be scrapped.
- When the major stressed structure loses stability at large, it should never get repaired and must be scrapped.
- When a crack is present on a structure or a weld, it can be properly reinforced according to the stress and crack conditions, and continued use is only allowed when it meets the original design requirements, otherwise it should be scrapped.

## PRESSURE-FIT PARTS

When assembling pressure-fit part, use a molybdenum disulfide base compound or equivalent to lubricate the mating surface.

## BEARINGS

1. When a bearing is removed, cover it to keep out dirt and abrasives. Clean bearings in nonflammable cleaning solvent and allow to drip dry. Compressed air can be used but do not spin the bearing.
2. Discard bearings if the races and balls (or rollers) are pitted, scored, or burned.
3. If bearing is found to be serviceable, apply a light coat of oil and wrap it in clean (waxed) paper. Do not unwrap reusable or new bearings until they are ready to install.
4. Lubricate new or used serviceable bearings before installation. When pressing a bearing into a retainer or bore, apply pressure to the outer race. If the bearing is to be installed on a shaft, apply pressure to the inner race.

## GASKETS

Check that holes in gaskets align with openings in the mating parts. If it becomes necessary to hand-fabricate a gasket, use gasket material or stock of equivalent material and thickness. Be sure to cut holes in the right location, as blank gaskets can cause serious system damage.

## BOLT USAGE AND TORQUE APPLICATION

### NOTICE

*Self-locking fasteners, such as nylon insert and thread deforming locknuts, are not intended to be reinstalled after removal.*

1. Always use new replacement hardware when installing locking fasteners. Use bolts of proper length. A bolt which is too long will bottom before the head is tight against its related part. If a bolt is too short, there will not be enough thread area to engage and hold the part properly. When replacing parts, use only those having the same specifications of the original, or one which is equivalent.
2. Unless specific torque requirements are given within the text, standard torque values should be used on heat-treated bolts, studs, and steel nuts, in

accordance with recommended shop practices.  
(See [Fastener Torque Specifications, page 2-17](#))

## HYDRAULIC LINES AND ELECTRICAL WIRING

Clearly mark or tag hydraulic lines and electrical wiring, as well as their receptacles, when disconnecting or removing them from the unit. This will assure that they are correctly reinstalled.

## HYDRAULIC SYSTEM

1. The primary enemy of a hydraulic system is contamination. Contaminants enter the system by various means, e.g., using inadequate hydraulic oil, allowing moisture, grease, filings, sealing components, sand, etc., to enter when performing maintenance.
2. Keep the system clean. If evidence of metal or rubber particles are found in the hydraulic system, drain and flush the entire system.
3. Disassemble or reassemble parts on clean work surface. Clean all metal parts with non-flammable cleaning solvent. Lubricate components, as required, to aid assembly.

## LUBRICATION

Service applicable components with the amount, type, and grade of lubricant recommended in this manual, at the specified intervals. When recommended lubricants are not available, consult your local supplier for an equivalent that meets or exceeds the specifications listed.

## BATTERY

Clean battery, using a non-metallic brush and a solution of baking soda and water. Rinse with clean water. After cleaning, thoroughly dry battery and coat terminals with an anti-corrosion compound.

## PINS AND COMPOSITE BEARING

1. Pinned joints should be disassembled and inspected if the following occurs:
  - Excessive sloppiness in joints.
  - Noise originating from the joint during operation.

2. The composite bearing should be replaced if the following occurs:
  - Frayed or separated fibers on the liner surface.
  - Cracked or damaged liner backing.
  - Bearing that have moved or spun in their housing.
  - Debris embedded in liner surface.
3. Pins should be replaced if any of the following is observed (pin should be properly cleaned prior to inspection):
  - Detectable wear in the bearing area.
  - Flaking, peeling, scoring, or scratches on the pin surface.
  - Rusting of the pin in the bearing area.
4. Reassembly of pins and composite bearing:
  - Housing should be blown out to remove all dirt and debris. Bearings and bearing housings must be free of all contamination.
  - Bearing/pins should be cleaned with a solvent to remove all grease and oil. The composite bearing is a dry joint and needs no lubricating.
  - Pins should be inspected to ensure it is free of burrs, nicks, and scratches which would damage the bearing during installation and operation.

**NOTICE**

*The oxidization exceeding a certain period will increase the resistance of the connector and eventually lead to electrical failure.*

2. Silicone grease should be applied to each electrical cord that is exposed at the outside of the connector to prevent short circuit. Besides, the joint between the male and female connectors should also be applied with silicone grease. Other joints that may allow entry of water into the connectors, like the area around the anti-pull buckle, should be properly sealed as well.

**NOTICE**

*Since the electrical conductivity of cleaning solvent is superior to that of water, it is mostly likely that this will occur when using pressure cleaning method to clean the machine.*

3. Silicone grease should be applied to each contact of the connectors for battery case and charger.

**NOTICE**

*The setting type sealant can be used to avoid short circuit and keep the connections tidy, but it will make the future removal of pins more difficult.*

## APPLICATION OF INSULATING SILICONE GREASE TO ELECTRICAL CONNECTIONS

Insulating silicone grease should be applied to all electrical connections for the purpose of :

- Avoiding oxidization of the mechanical joints between the male pins and female pins.
- Avoiding electrical failure due to low conductivity between the pins in humid environment.

The following procedure should be observed to apply the insulating silicone grease to the electrical connections. The procedure applies to all plugged connections outside of the power distribution box. The silicone grease is not suitable for the connectors with enclosed outer surface.

1. Prior to the machine assembling, apply silicone grease around the male pins and female pins inside the connectors to prevent oxidization. An injector may be used for the convenience of operation.

# 5 MAINTENANCE PROCEDURES


This section provides specific procedures for scheduled maintenance inspection.

 **WARNING**


**UNSAFE OPERATION HAZARD**



**Improper maintenance may result in death, severe injury or machine damage.**

 **WARNING**

**HIGH PRESSURE HAZARD**



**Before releasing or removing the hydraulic components, release the hydraulic oil pressure in the hydraulic circuit, particularly with the counterweight valve.**

Observe the following rules :

- Preventive maintenance procedure should be established by the user according to the manufacturer's recommendations, machine operational environment and intensity of use, which should include both the regular inspection and the annual inspection.
- Professionally trained, qualified personnel must conduct routine maintenance inspections on this machine.
- Daily routine maintenance inspections must occur during normal operation of the machine. Maintenance inspectors must carry out inspection and maintenance according to the repair & inspection report and must complete the repair & inspection report.
- Regular maintenance inspections must occur by operators and at quarterly, biannual and annual intervals by qualified, trained personnel. Qualified, trained personnel must check and maintain the machine according to the repair & inspection report and must complete the repair & inspection report.
- Immediately remove a damaged or malfunctioning machine, mark it and stop using it.
- Repair any damaged or malfunctioning machine before operating it.
- Keep all machine inspection records for at least 10 years or until the machine is no longer in use or as required by machine owner/company/custodian.

- The inspection and maintenance intervals depend on the manufacturer's recommendations, and should also be appropriate to the operational conditions and environment.
- Conduct a quarterly inspection on machines that have been out of service for a period lasting longer than three months.
- While maintaining the machine, replace any parts on the machine using the same parts or the same parts of the original machine.
- Unless otherwise specified, perform the maintenance procedures according the following terms and conditions:
  - Park the machine on flat, level and solid ground.
  - Place the machine in non-operating position.
  - Turn the key switch on ground controller to OFF position and remove the key to prevent unauthorized use of the machine.
  - Pull out the red emergency stop buttons on ground and platform controls to OFF position to avoid unintended start-up of the operating system.
  - Turn off the main power switch.
  - Disconnect all DC power supply.
  - Lock all wheels to prevent movement of the machine.

## CONDUCTING A PRE-DELIVERY INSPECTION

When the machine owner/company changes, in addition to conducting a pre-delivery inspection, the corresponding inspection shall be carried out according to the maintenance schedule requirement and repair & inspection report. When conducting a pre-delivery inspection, comply with the following requirements:

1. It is the responsibility of the machine owner/company to perform a pre-delivery inspection.
2. Follow this procedure each time before delivery. Performing a pre-delivery inspection could reveal potential problems with the machine before you begin putting the machine into service.
3. Never use a damaged or malfunctioning machine. Tag the machine and do not use it.

4. Only professionally trained, qualified personnel may repair the machine and must follow the procedures as stated in *operation manual* and *maintenance manual*.
5. A competent operator must conduct daily maintenance on this machine as stated in *operation manual* and *maintenance manual*.

Before delivering the machine, complete the following record using these instructions:

1. Prepare the machine before delivery, which includes performing a pre-delivery inspection, following maintenance procedures and performing functional inspections.
2. Use the following table to note the results. After each section is complete, mark the appropriate box.
3. Record the inspection results. If any inspection results are "NO", the machine must be stopped and re-inspected after repair is completed and marked in the box marked "inspection".

**Table 5-1**

<b>PREPARE THE WORK RECORD BEFORE DELIVERY</b>			
Model			
Serial No.			
<b>Inspection Item</b>	<b>YES/Machine is in Good Condition</b>	<b>NO/Machine Has Damage or Malfunction</b>	<b>REPAIRED/Machine Has Been Repaired</b>
Pre-operational Inspection			
Maintenance Procedure			
Functional Inspection			
Machine Buyer/ Renter			
Inspector Signature			
Inspector Title			
Inspector Company			

## FOLLOWING A MAINTENANCE SCHEDULE

Regular maintenance inspections must occur daily, quarterly, biannually (every 6 months) and annually, and must be performed by the personnel qualified in the maintenance and service of the machine models involved. Use the table to help you adhere to a routine maintenance schedule.

**Table 5-2**

<b>INSPECTION INTERVAL</b>	<b>INSPECTION PROCEDURES</b>
Every day or every 8 hours	A
Every quarter or every 250 hours	A+B
Every half a year or every 500 hours	A+B+C
Every year or every 1000 hours	A+B+C+D

## COMPLETING A REPAIR & INSPECTION REPORT

1. The Repair & Inspection Report is divided into four parts (A, B, C and D) according to the time requirements of the maintenance schedule and the maintenance procedure requirements.
2. The Repair & Inspection Report shall include the inspection form of all regular inspections.
3. Duplicate the Repair & Inspection Report template for each inspection. Store the completed forms for 10 years or until the machine is no longer in use or as required by machine owner/company.
4. Use the following table to record the results. After one item is complete, mark the appropriate box.
5. If any inspection item is marked as "NO", the machine must be stopped and re-inspected after repair is completed and the box marked "- REPAIRED" shall be checked. Select the appropriate inspection procedure based on the inspection type.

Table 5-3

<b>REPAIR &amp; INSPECTION REPORT</b>				
Model				
Serial No.				
<b>Checklist A Procedures</b>				
<b>Items</b>	<b>YES/Machine is in Good Condition</b>	<b>NO/Machine Has Damage or Malfunction</b>	<b>REPAIRED/ Machine Has Been Repaired</b>	<b>Problem Description</b>
A-1 Inspect All Manuals				
A-2 Inspect All Decals				
A-3 Inspect Damaged, Loose or Lost Parts				
A-4 Inspect Hydraulic Oil Level				
A-5 Inspect Hydraulic Oil Leakage				
A-6 Inspect Fuel Level				
A-7 Inspect Fuel Leakage				
A-8 Perform Oscillation Cylinder Exhausting				
A-9 Check Battery Level				
<b>Checklist B Procedures</b>				
<b>Items</b>	<b>YES/Machine is in Good Condition</b>	<b>NO/Machine Has Damage or Malfunction</b>	<b>REPAIRED/ Machine Has Been Repaired</b>	<b>Problem Description</b>
B-1 Inspect and Replace Hydraulic Oil Tank Return Filter Element				
B-2 Inspect Rim, Tire and Fasteners				
B-3 Inspect Hydraulic Oil				
B-4 Inspect Electrical Wiring				
B-5 Inspect Emergency Lowering				
B-6 Inspect Air Filter of Hydraulic Tank				
B-7 Replace High-pressure Filter Element				
B-8 Test Driving Speed				
B-9 Inspect Length and Angle Sensors				

<b>REPAIR &amp; INSPECTION REPORT</b>				
B-10 Inspect Tilt Protection				
B-11 Inspect Drive Reducer Oil Level				
B-12 Inspect Slewing Reducer Oil Level				
B-13 Inspect Slewing Bearing Bolts				
B-14 Lubricate Slewing Bearing				
B-15 Inspect Platform Oscillation Cylinder Fasteners				
B-16 Test Cylinder Drift				
B-17 Inspect Counterbalance Valve Locking				
B-18 Test Oscillation Outriggers and Oscillation Multi-way Valve Lever				
B-19 Inspect Battery				
B-20 Test Braking Distance				
<b>Checklist C Procedures</b>				
Items	YES/Machine is in Good Condition	NO/Machine Has Damage or Malfunction	REPAIRED/ Machine Has Been Repaired	Problem Description
C-1 Inspect Boom Extending/ Retracting Wire Ropes and Pulleys				
C-2 Replace Hydraulic Tank Air Filter				
C-3 Inspect Weighing System				
<b>Checklist D Procedures</b>				
Items	YES/Machine is in Good Condition	NO/Machine Has Damage or Malfunction	REPAIRED/ Machine Has Been Repaired	Problem Description
D-1 Replace Drive Reducer Gear Oil				
D-2 Replace Slewing Reducer Gear Oil				
D-3 Replace Hydraulic Oil				
D-4 Replace Hydraulic Tank Suction Filter				

<b>REPAIR &amp; INSPECTION REPORT</b>				
D-5 Inspect Boom Wear Pads				
User				
Inspector Signature				
Inspection Date				
Inspector Title				
Inspector Company				

## MAJOR MODIFICATION AND REPAIR RECORD

1. A major modification/repair is a modification/repair made to all or part of a machine that affects the stability, strength or performance of the machine.
2. Each time the machine owner/company makes a major modification/repair to the machine, it should be documented using the form below. Keep the form properly until the machine is taken out of service, or as requested by the machine owner/company.
3. Major modifications/repairs to the machine must be performed by a qualified service technician.
4. The machine must be inspected and verified after major modifications/repairs, with the inspection items including but not limited to all items in the maintenance and inspection report.
5. If the inspection result of each item in the Maintenance and Inspection Report is "YES", the "Machine Status after Modification/Repair" in the form will be "Good" and the machine can be used. If either inspection result is "NO", the machine must be re-inspected after the repair is completed until the machine is in "Good" condition before continuing to use the machine.

**Table 5-4**

<b>Major Modification and Repair Record</b>					
Model					
Serial No.					
Date	Problem Description	Modification/Repair Item	Machine Status after Change	Repairman's Company and Position	Repairman Signature


## CHECKLIST A PROCEDURES

### A-1 Inspect All Manuals

Keeping the *Operation Manual* and *Maintenance Manual* in appropriate place is vital to safe machine operation. The manuals should be kept at all times in the manual storage container on the platform. If the manual is missing or illegible, it will fail to provide the information necessary for safe machine operation.

- Verify the manual storage container is properly installed on the platform.
- Verify the *Operation Manual* and *Maintenance Manual* are in good condition and placed inside the storage container.
- Verify each page of the manuals is legible and intact.
- Return the manual to the storage container after each use.

**Note:** If the manuals need to be replaced, please contact Hunan Sinoboom Intelligent Equipment Co., Ltd..

### A-2 Inspect All Decals

Ensuring all decals in good condition is vital to safe machine operation. Decals serve not only to alert the operator to potential hazards but also to provide the user with information regarding operation and maintenance. An illegible decal will fail to provide correct instructions for the operator, which may lead to the occurrence of unsafe operation.

- Refer to the Decals/Nameplate Inspection in *Operation Manual* and use the list and chart of decals to determine the correct location of a decal.
- Verify all decals are legible and free of damage, and replace in time if necessary.

**Note:** If the decals on the machine need to be replaced, please contact Hunan Sinoboom Intelligent Equipment Co., Ltd..

### A-3 Inspect Damaged, Loose or Lost Parts

Before each use or work shift, check the machine for any damaged, improperly installed, loose or lost parts and unauthorized changes:

- Electrical components, wiring, cables and safety ropes
- Hydraulic hoses & fittings, hydraulic cylinder and manifolds
- Hydraulic tank
- Battery pack and its connection
- Drive motor & reducer, slewing motor & reducer
- Boom wear pads and telescopic axle wear pads
- Limit switch and horn
- Tires and rims
- Alarms and lighting (if equipped)
- Platform (including rails, floor plate, safety lock, brackets and entry door)
- Personal protection equipment
- Emergency control equipment
- Operation instructions, warning and control decals
- Structure and welding cracks
- Nuts, bolts and other fasteners

<b>NOTICE</b>
<i>If any damaged part, incorrect installation or missing part is discovered, please replace it immediately and install it correctly; if any fastener is found detached or loose, please secure it immediately.</i>

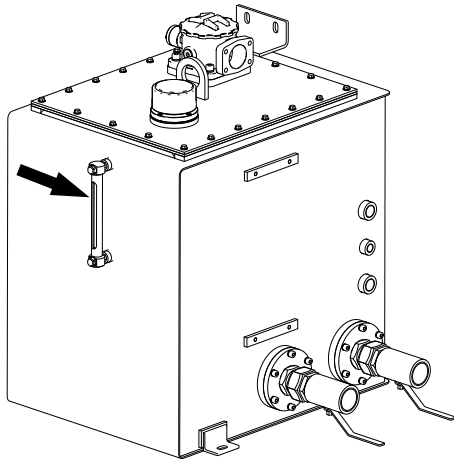
### A-4 Inspect Hydraulic Oil Level

Ensuring appropriate hydraulic oil level is vital to proper operation of the machine. If too high, the oil will spill out from the oil tank during machine operation, if too low, the oil pump will suction air and damage hydraulic

components. Performing daily inspection of the hydraulic oil level will help you determine if a problem exists in the hydraulic system.

Perform the following procedures with the boom in stowed position:

1. Open the left turntable cover to make visual inspection of the sides of hydraulic tank, the hydraulic oil level should be within the marking range of oil level indicator.



**Figure 5-1**

2. Ensure the hydraulic tank body and its connections are free of leaks.
3. Add oil as needed. Never overfill the tank.

**Table 5-5**

CUSTOMER REQUIREMENTS	HYDRAULIC OIL MARK
Normal-temperature region 0°C to 40°C (32°F to 104°F)	L-HM46
Cold region -25°C to 25°C (-13°F to 77°F)	L-HV32
High-temperature region greater than 40°C (104°F)	L-HM68
Extremely cold region less than -30°C (-22°F)	Special programmes need to be identified.

**NOTICE**

*Different hydraulic oils can be added according to customer requirements upon factory delivery, but cannot be mixed.*

**A-5 Inspect Hydraulic Leakage**

Preventing the hydraulic oil from leaking is vital to safe and normal machine operation. If the hydraulic leaks fail to be discovered, it will lead to hazardous situations, reduce the machine performance and damage components.

Inspect the area on or around the following components for hydraulic spill, dripping or residues:

- Hydraulic tank, filters, hoses, fittings, and emergency power unit
- All hydraulic cylinders, manifolds and pumps
- Boom system
- Slewing bearing
- Drive chassis
- Areas around the machine

**A-6 Functional Tests**

Testing each machine function is vital to safe machine operation. If any function operates improperly, it will pose dangers to safe operation. Ensure each function operates smoothly and reliably, without shaking, sharp or unusual noise.

**WARNING**

**UNSAFE OPERATION HAZARD**



**Be sure to observe the instructions and safety rules noted in this manual and *Operation Manual*, otherwise it may lead to death or severe injury.**

For the specific procedure for functional tests, please reference the Pre-operation Function Test section in *Operation Manual*. Before performing the functional test, ensure that the safety rules in the operation manual are fully read and understood.

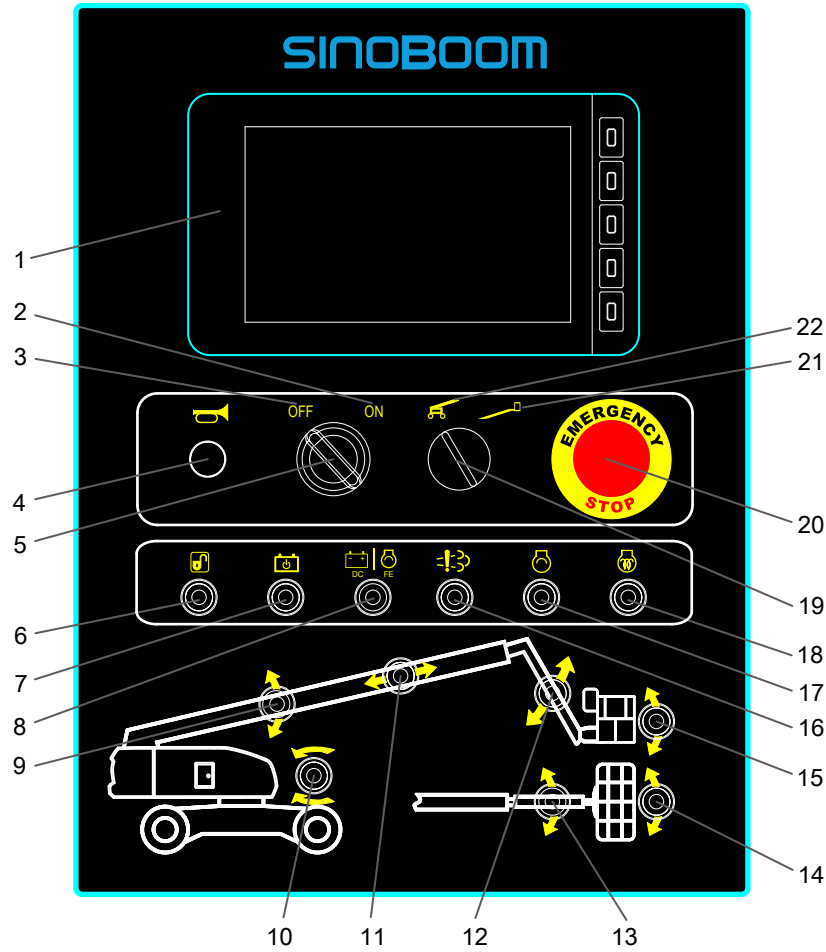


Figure 5-2 Ground Controller

Table 5-6

1. Display (shown below)	9. Main boom up/down switch	17. Not used
2. ON position	10. Turntable rotate switch	18. Not used
3. OFF position	11. Main boom telescope switch	19. Ground/Platform select switch
4. Horn button	12. Jib up/down switch-TB26EJ Plus&28EJ Plus only	20. Emergency stop button
5. Key switch	13. Jib rotate switch-not used	21. Platform control position
6. Enable switch	14. Platform rotate switch	22. Ground control position
7. Emergency power switch	15. Platform level switch	
8. Not used	16. Not used	

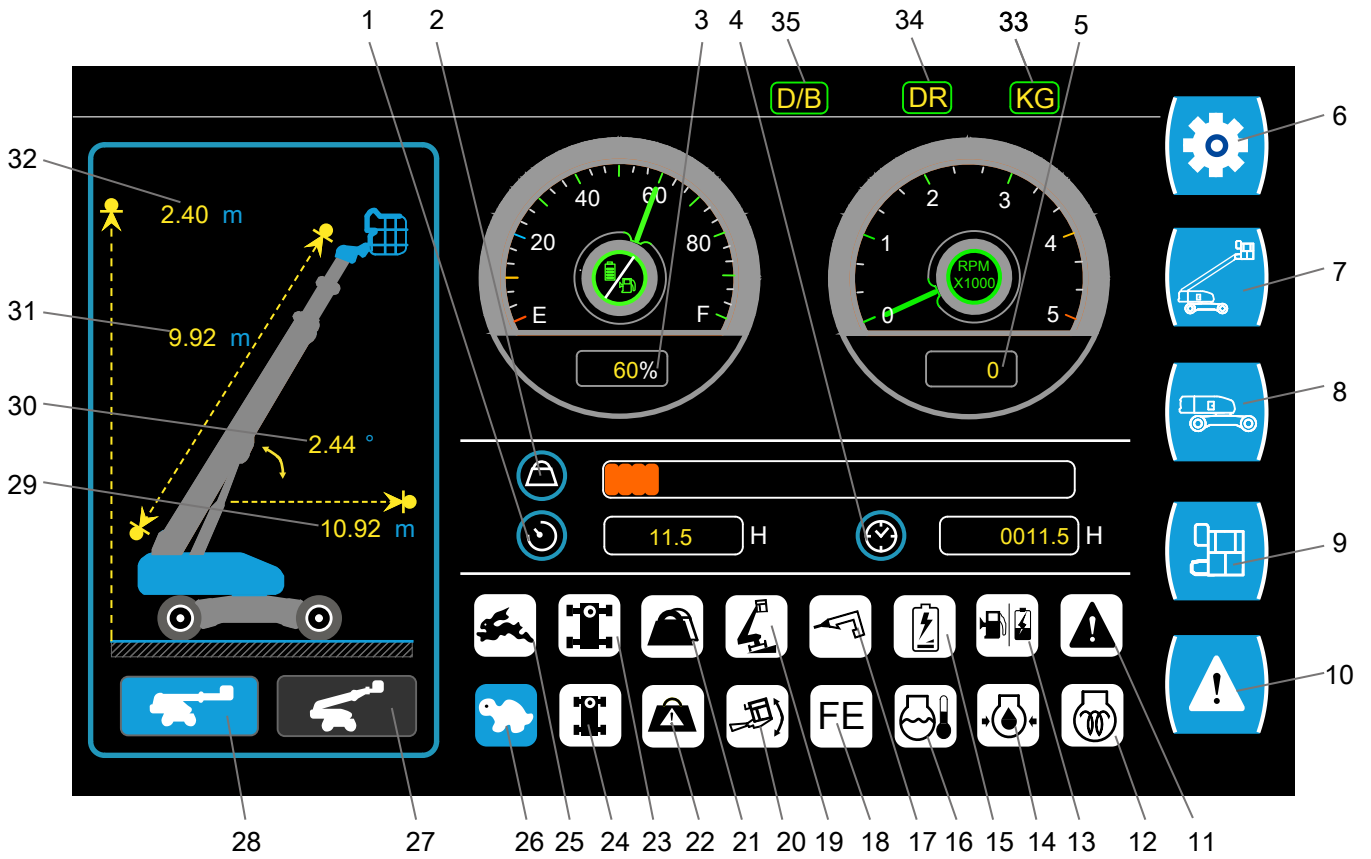


Figure 5-3 Ground Controller Display

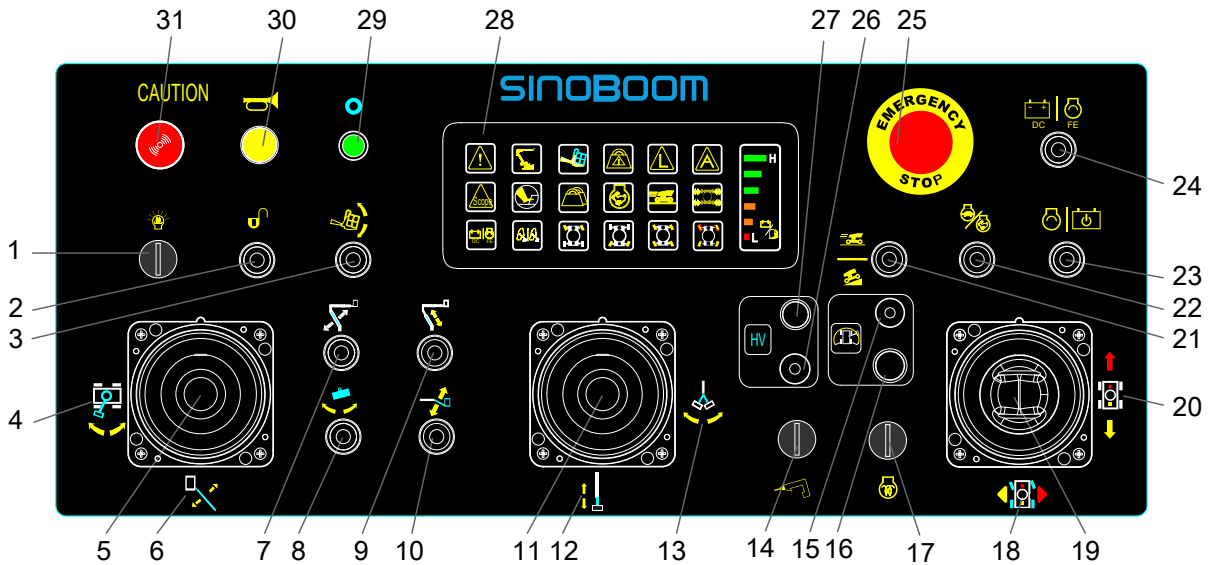
Table 5-7

1. Current work hours	13. Low battery alarm	25. Not used
2. Platform load	14. Not used	26. Not used
3. Battery gauge	15. Low battery alarm	27. Operating position
4. Accumulated work hours	16. Not used	28. Non-operating position
5. Tachometer	17. Inverter on	29. Boom horizontal reach
6. Setup menu	18. Not used	30. Boom angle above horizontal
7. Machine info	19. Chassis tilt alarm	31. Boom length
8. Turntable info	20. Platform tilt alarm	32. Platform height
9. Platform info	21. Heavy load indicator	33. Overload limit
10. Alarm message	22. Overload alarm	34. Drive limit (operating position)
11. Fault alarm	23. Not used	35. Drive and boom functions allowed

12. Not used	24. Not used	
--------------	--------------	--

**Note:**

1. When the Overload Limit symbol appears, if the platform is overloaded, a series of functions will be restricted if the machine is in operating position. Details are provided below.
2. When the Drive Limit symbol appears, it indicates the drive function is restricted if the machine is in operating position.
3. When the Drive & Boom Function Allowed symbol appears, it indicates the drive and boom functions are allowed to operate simultaneously.



**Figure 5-4 Platform Controller**

**Table 5-8**

1. Work light switch (if equipped)	12. Main boom telescope direction	23. Emergency power switch
2. Release switch (if equipped)	13. Not used	24. Not used
3. Platform level switch	14. Inverter switch (if equipped)	25. Emergency stop switch
4. Turntable rotate direction	15. Rear position indicator light	26. Not used
5. Main boom lift/turntable rotate control handle	16. Rear position travel drive switch	27. Not used
6. Main boom lift direction	17. Not used	28. Malfunction indicator panel
7. Not used	18. Steer direction	29. Power indicator light
8. Platform rotate switch	19. Drive/steer control handle	30. Horn button
9. Not used	20. Drive direction	31. Buzzer button

10. Jib up/down switch-TB26EJ Plus&28EJ Plus only	21. Drive high/low speed select switch	
11. Main boom telescope/jib rotation proportion control handle	22. Not used	

### A-7 Perform Maintenance after 30 Days

Perform maintenance for a new machine after the machine is used for 30 days or 50 hours. After that, perform other maintenance items as scheduled.

Perform the following procedures:

- B-1 Inspect and replace the return filter of hydraulic oil tank.
- B-2 Inspect rims, tires and fasteners
- B-13 Inspect slewing bearing bolts
- B-15 Inspect platform rotate cylinder fasteners

### A-8 Exhaust Oscillate Cylinder

**NOTICE**

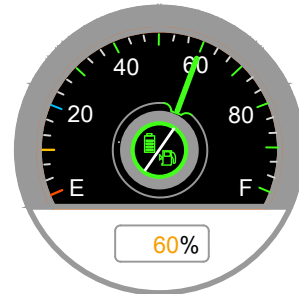
*While exhausting the oscillate cylinder, be sure to keep the platform in stowed position.*

Before the first use of the new machine, the oscillate cylinder must be exhausted. This procedure must also be performed if the oscillate cylinder or counterbalance valve is replaced.

1. Place a wooden block which measures 120mm ( 4.7 in ) with slope surface in front of the machine.
2. Drive the machine to rest the front left wheel upon the block and drive off.
3. Drive the machine to rest the front right wheel upon the block and drive off.
4. Repeat the steps 2 and 3 until the oscillate cylinders on both sides have been successfully exhausted.
5. Inspect the counterbalance valve locking.

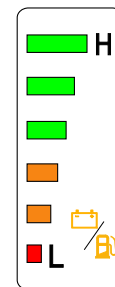
### A-9 Check Battery Level

1. Turn the ground/platform select switch at the ground controller to the ground control position, pull out the emergency stop button on the ground controller to the ON position, and then turn the key switch at the ground controller to the ON position, then the display panel of the ground controller will display the battery level in percentage.



**Figure 5-5**

2. Or turn the ground/platform select switch at the ground controller to the platform control position, pull out the emergency stop button at the ground controller and platform controller to the ON position, and then turn the key switch at the ground controller to the ON position, then the display panel of the platform controller will display the battery capacity with progress bar.



**Figure 5-6**


**NOTICE**

*When the battery level is about 20%, the battery must be charged. It is forbidden to charge the battery after the it runs out.*

## CHECKLIST B PROCEDURES

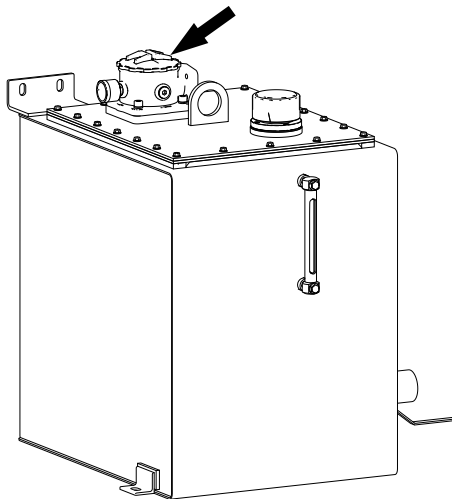
### B-1 Replace Hydraulic Oil Tank Return Filter Element

Replacing the hydraulic tank return filter on a regular basis is vital to proper machine operation and extending service life. Repeated use of a unqualified cleanliness or blocked filter could cause damage to the machine components. Replace the return filter more frequently in harsh environments.

<b>! WARNING</b>	
	<p><b>BURN HAZARD</b></p> <p>Allow the hydraulic oil to cool to room temperature before servicing the hydraulic system.</p>


<b>NOTICE</b>	
<i>Shut off the machine before inspection.</i>	

1. Open the left side cover of the turntable.
2. Locate the return filter of hydraulic oil tank.



**Figure 5-7**

3. Use a wrench to remove the return filter.

<b>! WARNING</b>	
<b>HIGH PRESSURE HAZARD</b>	
	<p>Slowly remove the hydraulic components to reduce hydraulic oil pressure. High hydraulic oil pressure could penetrate the skin. Seek medical attention immediately.</p>

4. Loosen the filter end cap and remove the filter element.
5. Apply a thin coat of oil film over the new gasket of return filter.
6. Clean the filter housing and install the new element, then re-install the return filter.
7. Clean the oil that may spill during the procedure.
8. Start the machine from the ground controller.
9. Verify the filter and hydraulic components are free of leaks.

### B-2 Inspect Rim, Tire and Fasteners

Good maintenance of rims and tires is vital to safe machine operation. The machine might tip over if the rim or the tire has problems. Repair any problems with the rims and tires before operating the machine.

The machine is equipped with solid tires that do not need to be inflated.

1. Inspect the tires on a daily basis for damage or excessive wear. If any of the following condition occurs, immediately remove the machine from service and replace tires or tire assembly (including rims). For the requirements and procedure for the replacement, please reference [Tires and Rims, page 6-6](#).
  - Ply separation of tires, i.e., circumferential rips or lamination occurring to in between the rubbers.
  - Detachment from rims: the rubber comes off from the steel rims.
  - Rubber surface locally peeling off in lumps.
  - Rubber cracks in radial direction.
  - Rubber worn to the wear mark.
2. Inspect the lug nuts are torqued to specification (700Nm[517ft-lb]).

### NOTICE

*Tighten the lug nuts prior to the first use or after each tire removal, inspect and retorque every 3 months or 150 hours of operation.*

### B-3 Inspect Hydraulic Oil

Inspecting and replacing the hydraulic oil is vital to proper machine operation and extending service life. The machine may be unable to operate properly if the cleanliness of hydraulic oil is unqualified, and the hydraulic parts may be damaged if using contaminated oil. Replace the hydraulic oil often, especially when the service environment is very harsh.

**Note:** Due to wear and tear on the mesh components, metal particles may appear in the hydraulic fluid or filter of the new machine.

### WARNING



#### BURN HAZARD

**Before maintaining the hydraulic system, allow the hydraulic fluid to cool to room temperature.**

Replace the hydraulic oil if any of the following conditions exist :

- The hydraulic oil is milky white and cloudy.
- The hydraulic oil is blackened.
- Obtain a sample of the hydraulic oil and inspect it in sunlight. Rub the oil between two fingers to determine if it contains metal particles.
- The hydraulic oil has an abnormal smell.

See [D-3 Replace Hydraulic Oil, page 5-23](#) for the replacement steps.

### B-4 Inspect Electrical Wiring

Maintaining electrical wiring in good condition is vital to safe operation and good machine performance. Continued use of the machine with damaged electrical wiring or in corrosive environment will cause severe injury. Before operating the machine, be sure to replace or repair the damaged or corroded electrical wires.

### WARNING



#### ELECTROCUTION HAZARD

**Before inspecting the electrical wires, be sure to disconnect the battery and the charger on the AC outlet. Contact with hot or live circuits could result in death or serious injury.**

1. Inspect the following areas for damage or corrosion :
  - Turntable manifold wiring
  - Ground controller
  - Platform controller
2. Check the cable track system for damaged or corroded power cords.
3. Check each adjustable joint for loose connection and ensure the sensor wiring is free of damage.

### B-5 Inspect Emergency Lowering

When the electric motor fails, depending on the actual conditions, move the emergency power switch on the ground or platform controller to start the hydraulic pump, and meanwhile move the function switch to enable the boom lowering, retracting and rotating.

### NOTICE

- *The emergency power switch serves only for a short time of use (with the platform lowered to the maximum degree possible) when the electric motor fails.*
- *When the emergency power is in use, do not operate two or more functions simultaneously, otherwise the auxiliary motor and pump will get overloaded.*

#### Operating from the ground :

1. Turn the Ground/Platform select switch on the ground controller to the ground control position.
2. Pull out the emergency stop button on the ground controller to the ON position.
3. Turn the key switch on the ground controller to the ON position.
4. Move and hold the emergency power switch on the ground controller.
5. Move the corresponding boom function switch on the ground controller to lower the platform.

#### Operating from the platform :

1. Turn the Ground/Platform select switch on the ground controller to the platform control position.
2. Pull out the emergency stop buttons on both the ground and platform controllers to the ON position.
3. Turn the key switch on the ground controller to the ON position.
4. Move and hold the emergency power switch on the platform controller.
5. Move the corresponding boom function switch on the platform controller to lower the platform.

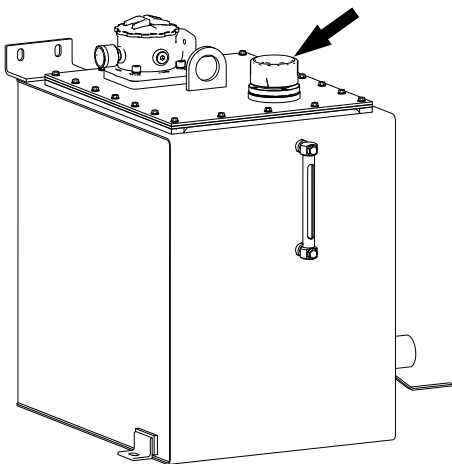
## B-6 Inspect Air filter of Hydraulic Tank

Keeping the breather cap of hydraulic tank in well-ventilated condition is vital to normal operation of hydraulic pump and extending service life. Unqualified cleanliness or blocked air filter of hydraulic tank may cause the hydraulic pump to suction improperly, and continued operation may result in component damage. The air filter of hydraulic tank should be inspected more often in hostile operating environment.

### NOTICE

*Shut off the machine before inspection.*

1. Remove the air filter of hydraulic tank.



**Figure 5-8**

2. Check the air filter element of hydraulic tank.
3. The air should pass through the air filter smoothly.
4. If the air has difficulty in passing through the air filter, observe the following steps to clean the air filter.
5. Use neutral solvent to clean the air filter, then blow dry and repeat the Step 2.
6. Install the air filter back to the hydraulic tank.

## B-7 Replace High-Pressure Filter Element

Replacing high-pressure filter element on a regular basis is vital to proper machine operation and extending service life. A dirty or blocked filter could cause the machine to work improperly, and continued operation may result in component damage. The high-pressure filter element should be replaced more often in hostile operating environment.

### WARNING

#### BURN HAZARD

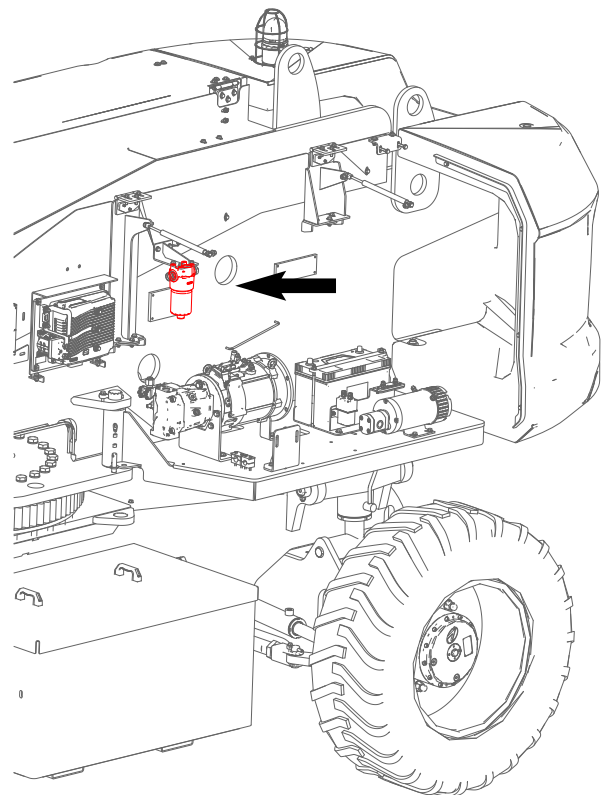


**Be cautious of hot hydraulic oil. Bodily contact with hot hydraulic oil may result in severe burn.**

### NOTICE

*Shut off the machine before inspection.*

1. Open the right side cover of turntable, and locate the high-pressure filter.



**Figure 5-9 High-pressure filter**

2. Place a suitable vessel under the filter.

- Remove the filter from the mounting bracket.

**WARNING**

**HIGH-PRESSURE HAZARD**

**Slowly remove the hydraulic elements to reduce the oil pressure. High-pressure oil may penetrate the skin. Should any injury occur, go to a doctor at once.**

- Replace the filter element as needed.
- Clean up the hydraulic oil spills.
- Start the machine from the ground controller.
- Inspect the high-pressure filter and relevant components for leakage.

### B-8 Test Drive Speed

- Depress the foot switch.
- Slowly push forward the drive/steer control handle to full drive speed.
- Move upward the drive high/low speed select switch on the platform controller to select the drive high speed.
- The test results should be as shown in the table below:

**Table 5-9**

POSITION	MAX DRIVE SPEED
Operating	1.1km/h (0.68mph)
Non-operating	4.8km/h (3 mph)

NOTICE

*If the drive speed exceeds the test results as shown above by 10%, please immediately tag and remove the machine from service.*

### B-9 Inspect Length and Angle Sensors

Regularly inspecting length and angle sensors is vital to safe machine operation. If the sensors can't function properly, it will pose dangers to machine operation.

#### Inspecting length sensor

#### 0kg≤platform capacity≤300kg (661 lb)

- Turn the Ground/Platform select switch at ground controller to the Ground.
- Pull out the emergency stop button at the ground controller to ON position.
- Turn the key switch at ground controller to ON position.
- Using the main boom lift and jib up/down function (if equipped), adjust the main boom and jib boom (if equipped) to horizontal.
- Using the main boom telescope function, extend the main boom.
- TB24E Plus: when the boom extends to the farthest (the ground display reads 21.5m), the buzzers at the ground and platform controller should be sounding, boom further extending and boom up/down should be restricted, but boom retracting and turntable rotating should be allowed.
- TB26E Plus&26EJ Plus&28EJ Plus: When the boom extends to the farthest (the ground display reads 20.6m), the buzzers at the ground and platform controller should be sounding, boom further extending and boom up/down should be restricted, but boom retracting and turntable rotating should be allowed.
- Using the main boom telescope switch, retract the boom.
- The boom can be fully retracted.

#### 300kg (661 lb)≤platform capacity≤454kg (1000 lb)

- Turn the Ground/Platform select switch at ground controller to the Ground.
- Pull out the emergency stop button at the ground controller to ON position.
- Turn the key switch at ground controller to ON position.
- Using the main boom lift and jib up/down function (if equipped), adjust the main boom and jib boom (if equipped) to horizontal.
- Using the main boom telescope function, extend the main boom.
- TB24E Plus: when the boom extends to the farthest (the ground display reads 19.18m), the buzzers at the ground and platform controls should be sounding, boom further extending and boom up/down should be restricted, but boom retracting and turntable rotating should be allowed.
- TB26E Plus&26EJ Plus&28EJ Plus: when the boom extends to the farthest (the ground display reads 18.65m of boom length), the buzzers at the ground and platform controls should be

sounding, boom further extending and boom up/down should be restricted, but boom retracting and turntable rotating should be allowed.

8. Using the main boom telescope switch, retract the boom.
9. The boom can be fully retracted.

## Inspecting angle sensor

1. Turn the Ground/Platform select switch at ground controller to the Ground.
2. Pull out the emergency stop button at the ground controller to ON position.
3. Turn the key switch at ground controller to ON position.
4. Using the main boom lift and jib up/down function (if equipped), adjust the main boom and jib boom (if equipped) to horizontal.
5. Using the main boom lift function, fully raise/lower the main boom.
6. When the main boom is raised to the upper limit of lift angle (ground display reads  $70^{\circ}[\pm 1^{\circ}]$ ), the boom should be prevented from further raising.
7. When the main boom is lowered to the lower limit of lift angle (ground display reads  $-12^{\circ}[\pm 1^{\circ}]$ ), the boom should be prevented from further lowering.
8. Using the boom telescope and up/down function, retract and lower the boom.
9. The boom can be fully retracted.

**Note:** The max allowable tolerance of the angle sensor is not greater than  $0.5^{\circ}$  within its full range of measurement.

## B-10 Inspect Tilt Protection

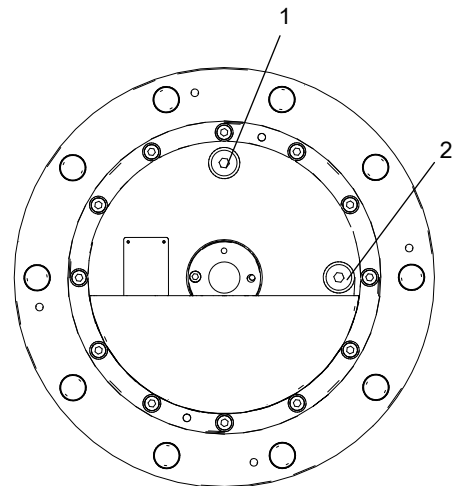
1. Start the machine.
2. With the machine in non-operating position, flip the level switch to exceed  $5^{\circ}$  in X (left-to-right)/Y (front-to-back) direction.
3. The tilt alarm sounds and the chassis tilt indicator light flashes, no function is restricted.
4. With the machine in operating position, flip the level switch to exceed  $5^{\circ}$  in X (left-to-right)/Y (front-to-back) direction.
5. The tilt alarm should sound with the chassis tilt indicator light flashing, some functions are restricted, but the boom retracting, turntable rotating and boom lowering when retracted to less than 1.2m (3ft 11in) should be allowed.

6. Place two wooden blocks under the two wheels on the left or right side of the machine. The wooden block measures  $750 \times 250 \times 190\text{mm}$  ( $2.46 \times 0.82 \times 0.6\text{ft}$ ). With the machine in non-operating position, drive it onto the two wooden blocks.
7. The tilt alarm should sound with the chassis tilt indicator light flashing, no function should be restricted.
8. Drive the machine off and remove the wooden blocks.
9. Place two wooden blocks under the two wheels on the front or rear of the machine. The wooden block measures  $750 \times 250 \times 265\text{mm}$  ( $2.46 \times 0.82 \times 0.87\text{ft}$ ). With the machine in operating position, drive it onto the two wooden blocks.
10. The tilt alarm should sound with the chassis tilt indicator light flashing, some functions are restricted, but the boom retracting, turntable rotating and boom lowering when retracted to less than 1.2m (3ft 11in) should be allowed.
11. Retract and lower the boom, drive off the machine in non-operating position and remove the wooden blocks.

## B-11 Inspect Drive Reducer Oil Level

Inappropriate gear oil level of drive reducers will reduce the machine performance, and continued use could result in component damage.

1. Drive the machine to rotate the reducer until one bolt at top and the other one at 90 degrees, as shown in the figure below.



**Figure 5-10**

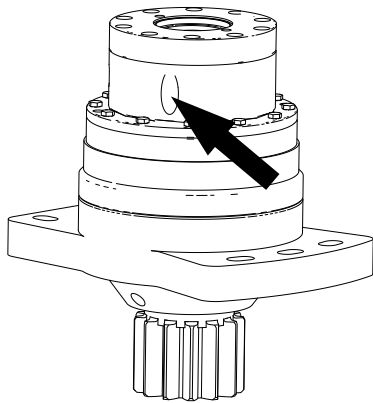
2. Remove the bolt #2, and check the oil level.
3. The oil level should be even with the bolt hole.

4. If necessary, add oil to the bolt hole.
5. Remove the bolt #1, add gear oil to the bolt hole #1 until the oil level is even with that of the bolt hole #2.
6. Install the bolts back.
7. Clean up the gear oil spills during the inspection.
8. Perform this inspection procedure to all drive reducers of the machine.

3. The oil level should be even with the plug hole.
4. If the oil level is lower than the plug hole, add gear oil.
5. Add gear oil from the fill port until the oil level is even with the plug hole.
6. Install the plug back.
7. Clean up the gear oil spills during the inspection.

**B-12 Inspect Slewing Reducer Oil Level**

Inappropriate gear oil level of slewing reducers will reduce the machine performance, and continued use could result in component damage.

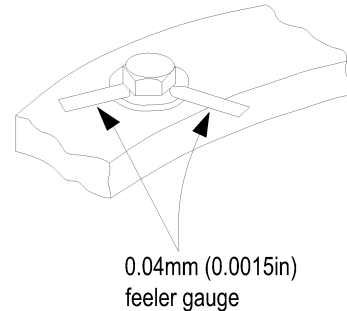


**Figure 5-11**

1. Open the left side cover of turntable, and locate the slewing reducer.
2. Remove the plug of fill port to check the oil level.

**B-13 Inspect Slewing Bearing Bolts**

Regularly inspecting the slewing bearing bolts is vital to proper machine operation. This inspection should be performed after the first 50 hours of operation and every 600 hours thereafter. If the bolts come off or get loose, replace with new ones. Apply threadlocker Loctite 272 to the new bolts and torque to specification. After the bolts are replaced and torqued, re-inspect the bolts for tightness.



**Figure 5-12**

**Inspecting the connecting bolts between chassis and slewing bearing**

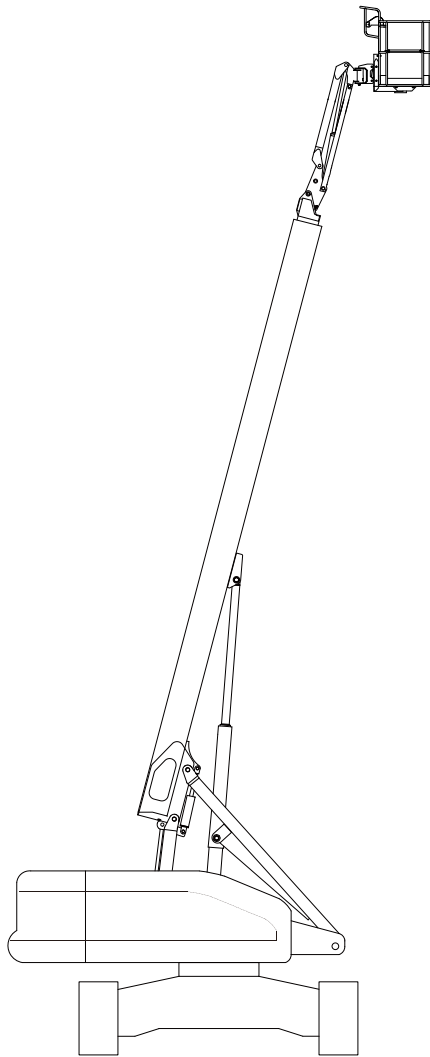


**Figure 5-13**

1. Fully extend the boom and raise it to horizontal position.
2. Locate the connecting bolts between chassis and slewing bearing.
3. As indicated by the arrow [Fig 5-11 , page 5-17](#), insert a 0.04mm feeler gauge in between the bolt and washer.

4. Ensure the feeler gauge won't go through the outside of bolt head to the bolt shank.
5. Rotate the turntable to inspect all the bolts.

**Inspecting the connecting bolts between turntable and slewing bearing**



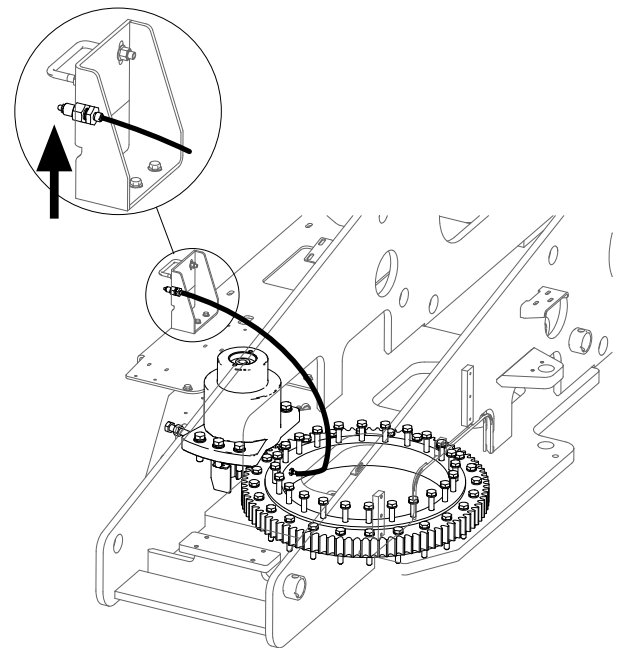
**Figure 5-14**

1. Fully retract the boom and raise it to full height.
2. Locate the connecting bolts between turntable and slewing bearing.
3. As indicated by the arrow [Fig 5-11 , page 5-17](#), insert a 0.04mm feeler gauge in between the bolt and washer.
4. Ensure the feeler gauge won't go through the outside of bolt head to the bolt shank.
5. Lower the main boom to horizontal position, and fully extend the main boom.
6. As indicated by the arrow [Fig 5-11 , page 5-17](#), insert a 0.04mm feeler gauge in between the bolt and washer.
7. Ensure the feeler gauge won't go through the outside of bolt head to the bolt shank.

## B-14 Lubricate Slewing Bearing

Regularly lubricating the slewing bearing from a long distance is vital to proper machine operation. The Lubricating frequency and the amount of lubricant used should be increased if the machine is operated on successive work shifts or in hostile environment.

- Lube point : 1 grease nipple (see the following figure)

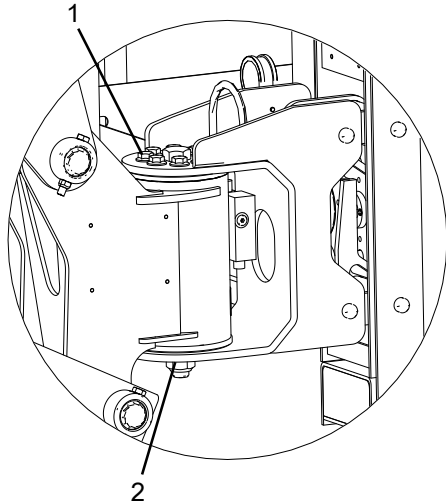


**Figure 5-15**

- Amount : as needed
- Lubricant : ZL-3 lithium based grease

## B-15 Inspect Platform Rotate Cylinder Fasteners

Regularly inspecting the platform rotate cylinder fasteners is vital to proper and safe machine operation.



**Figure 5-16**

1. Place the machine in stowed position.
2. Locate the platform rotate motor.
3. Inspect whether the bolt #1 as indicated in the above figure is properly torqued to specification ( 100Nm[74ft-lb] ).
4. If necessary, replace the bolt, torque to specified value, and apply threadlocker Loctite 272.
5. Inspect whether the nut #2 as indicated in the above figure is properly torqued to specification ( 630Nm[465ft-lb] ).
6. If the bolt needs to be replaced, be sure to torque to specification.

### B-16 Test Cylinder Drift

#### Platform drift

Measuring the drift from platform to ground: with rated load on platform and power off, fully extend the main boom. The maximum allowable drift in 10 minutes is 50mm (1.97 in). If the test result exceeds this value, please proceed as below.

#### Cylinder drift

**Table 5-10**

Cylinder Bore Diameter (mm/in)	Maximum Allowable Drift in 10 Minutes (mm/in)
63/2.48	0.96/0.037
80/3.15	0.63/0.025
100/3.94	0.39/0.015
125/4.92	0.23/0.009

Cylinder Bore Diameter (mm/in)	Maximum Allowable Drift in 10 Minutes (mm/in)
160/6.30	0.14/0.006
180/7.09	0.13/0.005
200/7.87	0.10/0.0038
220/8.66	0.08/0.0030

- Measure drift at cylinder rod with a calibrated dial indicator.
- The oil in cylinder must be at ambient temperature and consistent.
- The cylinder must be applied with normal load from the platform.
- The cylinder is acceptable if it passes this test.

**NOTE:** This information is based on 6 drops per minute cylinder leakage. Since the hydraulic oil expands or contracts due to thermal effect, thus the test value of cylinder drift may have a tolerance of 7/10000 for each temperature change of 1°C.

### B-17 Test Counterbalance Valve Locking

<b>NOTICE</b>
<p><i>After exhausting the oscillate cylinders, test the counterbalance valve locking, thereafter test the oscillate system quarterly, or after replacing any system component, or when any system malfunction is discovered.</i></p>

1. Place a 120mm (4.7 in) wooden block with bevel side in front of the front left wheel of the machine.
2. Extend the boom by at least 1.2m to place the machine in operating position.
3. Drive the machine to rest the front left wheel on the wooden block.
4. Slowly rotate the turntable to the right by 90 degrees.
5. The rear detection indicator light will illuminate, move the function switches to keep the boom horizontal and fully extended.
6. Inspect the oscillate cylinder, ensure the oscillate cylinder on the side with load applied is without any evidence of retracting, and then retract the boom.
7. Move the reverse drive switch to drive the machine off the wooden block.
8. The assistant on the ground should inspect whether the wheel on the front left or rear right still remains off the ground, and keep it elevated.

9. Slowly rotate the turntable to allow the turntable back to the center position (at the center between the two drive wheels).
10. Drive the machine forward or reverse, the oscillate cylinder on the front left wheel should be released to lower the wheel to come in close contact with the ground.
11. Perform the same procedure to test the oscillate cylinder on the front right side.
12. If the oscillate cylinder malfunctions, the malfunction must be cleared by qualified service technician before proceeding to next step.

## B-18 Test Oscillate Outriggers

**WARNING**

**TIPPING HAZARD**

To perform this test, the machine must be in stowed position.

1. Inspect the tie rod of multi-way valve is properly secured before machine startup.
2. Start the machine at the platform controller.
3. Drive the machine to allow the right steer wheel upon the kerb or a block with thickness of 120mm (4.7 in).
4. The other 3 wheels of the machine should come in close contact with the ground.
5. Drive the machine to allow the left steer wheel upon the kerb or a block with thickness of 120mm (4.7 in).
6. The other 3 wheels of the machine should come in close contact with the ground.
7. Drive the machine to allow the both steer wheels upon the kerb or a block with thickness of 120mm (4.7 in).
8. The non-steer wheels of the machine should come in close contact with the ground.

## B-19 Inspect Battery

The condition of battery could affect the performance of machine. Improper level of battery electrolyte or damaged cable and wiring may damage battery parts and pose dangerous conditions.

**WARNING**

ELECTROCUTION HAZARD

- Contact with live circuit may cause serious injury or death. Be sure to wear goggles, gloves and protective clothing.
- Remove all rings, watches and other jewelry.

**WARNING**

CHEMICAL BURN HAZARD

- Avoid the battery acid escaping out and contact with skin, if does, wash the skin with plenty of clear water and seek medical assistance.
- If battery acid spills, use water mixed with bicarbonate (baking soda) to neutralize the acid.

**Note:** Before performing this procedure, fully charge the battery, and hold it still for 24 hours to equalize the battery cells.

1. Ensure the battery cells are wired reliably with the locking nuts torqued to the specifications as below:

Nut type	Torque
M8	9 ~ 11Nm (6.6 ~ 8.1ft-lb)
M10	18 ~ 23Nm (13.2 ~ 17ft-lb)

**NOTICE**

*Improper connection may cause reduced performance, damaged terminals, fusions and even fires.*

2. Ensure the battery negative and positive are correctly connected.
3. Ensure the battery cable connections are not corroded.

**Note:** Adding a terminal protector and anti-corrosion sealant will prevent the terminals and cables from corrosion.

The instructions below are applied only for batteries requiring maintenance :

4. Wear goggles, gloves and protective clothing.
5. Remove the ventilation cover.
6. Top up the liquid gravity meter and drain it for two or three times, then take a sample from the battery electrolyte.
7. Measure the specific gravity of all battery cells in sequence and note down the readings.
8. If the ambient temperature is above 27°C (80°F), add 0.004 to calibrate the specific gravity reading for every 5°C (40°F) higher; if the ambient temperature is below 27°C (80°F), subtract 0.004 to calibrate the specific gravity reading for every 5°C (40°F) lower.
  - Result 1: if the specific gravity reading of each battery cell is 1.250 or higher, and the difference in the specific gravity readings is less than 0.050, proceed with the next step.
  - Result 2: if the specific gravity reading of one or more battery cells is below 1.250, it indicates the battery is running low and needs charging. After charging, measure the specific gravity, and if the Result 1 is obtained, proceed with the next step.
  - Result 3: if the difference in the specific gravity readings of any battery cells is greater than 0.050, equalize the battery pack and hold it still for 6 hours before re-measurement of the specific gravity. If the Result 1 is obtained, proceed with the next step.

**Note:** if the Result 1 cannot be obtained even after many attempts, the battery may have malfunctions.
9. Check the battery electrolyte level, and add distilled water to the required level if needed.
10. Install the ventilation cover to the battery.

**B-20 Test Braking Distance**

The brake device must be kept in good condition and work smoothly to ensure the normal and safe operation of the machine.

1. Depress the foot switch.
2. Slowly deflect the drive/steer proportional control joystick to full drive speed position.
3. Push upward the drive high/low speed select switch on the platform controller to switch the drive speed to high speed.
4. Quickly release the drive/steer proportional control joystick after the machine runs stably.
5. Measure the braking distance of the machine.

Result: the braking distance should be 0.8m (2.62 ft)~1.2m (3.94 ft).

<b>NOTICE</b>
<i>The brake must be able to hold the machine on any slope it is able to climb.</i>

**CHECKLIST C PROCEDURES**

**C-1 Inspect Boom Extending/Retracting Wire Ropes and Pulleys**

Boom extending/retracting wire ropes are used for the extension and retraction of boom. Boom extension and retraction should be performed smoothly and without hesitation, jerking and unusual noise.

<b>NOTICE</b>
<i>Shut off the machine before inspection.</i>

1. Remove the boom end cover.
2. Inspect for the followings :
  - In case of frayed, broken, corroded or kinked wire strands, and broken or damaged pulleys, replace the wire ropes and pulleys.
  - In case of foreign materials on the wire ropes, clean the wire ropes.
  - If the wire ropes are located outside the pulleys, adjust the wire ropes to the appropriate position.
  - Manually guide the wire ropes and inspect the tension. A properly tensioned wire rope should be impossible or hard to be moved.
3. If no deficiencies are discovered after inspection, install back the boom end cover.
4. Extend the boom approximately 0.6m.
5. Retract the boom, and visually inspect the movement of the 2nd and 3rd boom sections.
6. The retraction displacement of the 2nd boom section should not be more than 1/2 that of the 3rd boom section.

<b>NOTICE</b>
<i>The wire ropes and pulleys should be replaced together, i.e., if the wire rope is replaced, the matching pulley should also be replaced.</i>

C-2 Replace Air filter of Hydraulic Tank

Keeping the breather cap of hydraulic tank in well-ventilated condition is vital to normal operation of hydraulic pump and extending service life. Dirty or blocked air filter of hydraulic tank may cause the hydraulic pump to suction improperly, and continued operation may result in component damage. The air filter of hydraulic tank should be inspected more often in hostile operating environment.


1. Using a wrench, remove the air filter of hydraulic tank ( located as shown in **Fig 5-7 , page 5-14** ) .
2. Install and tighten the new filter.

C-3 Inspect Weighing System


Before the test, fully raise and lower the boom and fully extend and retract the boom at least twice to ensure the pulley and track are adequately lubricated.

Table 5-11

MODES	TEST RESULTS
KG mode	<p><b>Under restricted configuration:</b> When the load does not exceed 454kg (1000 lb) , ensure that the platform is able to lift to the highest position. When the load exceeds 454kg (1000 lb) , the buzzer will sound continuously, the overload indicator light will flash, the display screen will indicate platform overload, all motion functions are restricted and will not resume until the excessive load is removed.</p> <p><b>Under unrestricted configuration:</b> When the load does not exceed 300kg (661 lb) , ensure that the platform is able to lift to the highest position. when the load exceeds 300kg (661 lb) , the buzzer will sound continuously, the overload indicator light will flash, the display screen will indicate platform overload, all motion functions are restricted and will not resume until the excessive load is removed.</p>
Non-KG mode	<p><b>Under restricted configuration:</b> When the load does not exceed 454kg (1000 lb) , ensure that the platform is able to lift to the highest position. When the load exceeds 454kg (1000 lb) , the buzzer will sound continuously, the overload indicator light will flash, the display screen will indicate platform overload, some motion functions will be restricted, but boom retracting, turntable rotating and boom lowering after fully retracted is allowed. All motion functions will not resume until the excessive load is removed.</p> <p><b>Under unrestricted configuration:</b> When the load does not exceed 300kg (661 lb), ensure that the platform is able to lift to the highest position. When the load exceeds 300kg (661 lb), the buzzer will sound continuously, the overload indicator light will flash, the display screen will indicate platform overload, some motion functions will be restricted, but boom retracting, turntable rotating and boom lowering after fully retracted is allowed. All motion functions will not resume until the excessive load is removed.</p>

 **WARNING**

**TIPPING HAZARD**



While performing override operation on the machine, please avoid operation in a dangerous direction.

**NOTICE**

*Override operation is an emergency operation in an emergency state. Before conducting any override operation, please make sure the surrounding area and the whole machine are in a safe state, try to avoid operation in a dangerous direction and ensure personal safety.*

For overseas models, with the machine in the KG mode, if activating any function switch while flipping the emergency power switch after an overload alarm, the override operation should be performed, and the corresponding action can be performed. The time of the override operation and the actual weight on the platform are recorded on the display.

### CHECKLIST D PROCEDURES

#### D-1 Replace Drive Reducer Gear Oil

Regularly replacing drive reducer gear oil is vital to good machine performance and extending service life of the reducer.

1. Drive the machine to rotate the reducer to the position with one bolt at the bottom, as shown in the figure below.

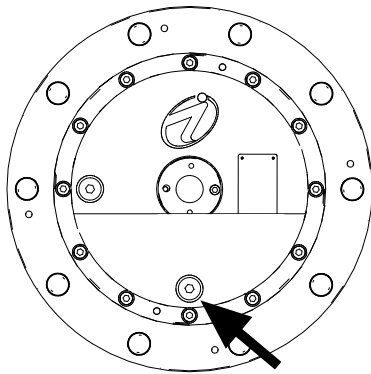


Figure 5-17

2. Place a suitable vessel under the bolt as indicated by the arrow in the figure.
3. Remove the bolt as indicated.
4. Fully drain the drive reducer gear oil to the vessel.
5. Mount back the loosened bolt.
6. Drive the machine to rotate the reducer until one bolt is at top and the other is at 90 degrees.

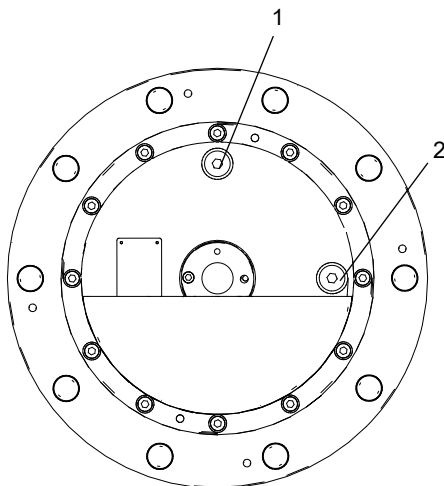


Figure 5-18

7. Remove the #1 and #2 bolts as indicated.
8. Add new gear oil to the port #1 until the oil level is even with that of the port #2.
9. Mount back the bolts.
10. Clean up the oil spills in performing the inspection procedure.
11. Perform the same procedure on all drive reducers of the machine.



#### D-2 Replace Slewing Reducer Gear Oil

Regularly replacing slewing reducer gear oil is vital to good machine performance and extending reducer service life.

1. Open the left side cover of turntable, and locate the slewing reducer.
2. Place a suitable vessel under the drain plug of the slewing reducer.
3. Remove the drain plug.
4. Fully drain the slewing reducer gear oil to the vessel.
5. Mount back the drain plug.
6. Remove the fill plug (for the location, reference [B-12 Inspect Slewing Reducer Oil Level, page 5-17](#)), add new gear oil to the fill port until the oil level is even with the bottom of the fill plug.
7. Mount back the fill plug.
8. Clean up the gear oil spills in performing the inspection procedure.

#### D-3 Replace Hydraulic Oil

Regularly replacing hydraulic oil is vital to good machine performance and extending service life. Unqualified cleanliness of oil may cause the machine to perform poorly and continued use may result in hydraulic component damage. It is recommended to change the hydraulic oil every year or every 1,000 hours. Particularly harsh working condition requires the oil changes to be performed more frequently.

 <b>WARNING</b>	
<b>BURN HAZARD</b>	
	<b>Before servicing the hydraulic system, allow the hydraulic oil to cool down to room temperature.</b>

## NOTICE

The inspection must be performed with the machine off.

Before re-installing the removed hoses and fittings, check whether the seals on the hoses and fittings are broken or missing; if any seal is damaged or missing, replace the seal with a new one, or replace the hose assembly and fittings directly. When installing hoses and fittings, tighten them according to the specified torque. See [Hydraulic Hose and Fitting Specifications, page 2-14](#).

1. Open the left side cover of turntable, and locate the hydraulic tank.
2. Close the hydraulic shutoff valve located on the side of hydraulic tank.
3. Remove the drain plug at the bottom of the tank, and completely drain the oil into a suitable vessel. For the capacity of hydraulic tank, please reference [Machine Specifications, page 2-1](#). After the oil is completely drained, re-install the drain plug.



## WARNING



### HIGH PRESSURE HAZARD

**Slowly remove the hydraulic elements to reduce the oil pressure. High-pressure oil may penetrate the skin. Should any injury occur, go to a doctor at once.**

4. Disconnect and plug the suction hoses.
5. Disconnect and plug the return hoses.
6. Remove the retaining bolts from the hydraulic tank cover, and remove the hydraulic tank cover.
7. Rinse out the inside of the tank using a mild solvent, and open the drain plug to empty the solvent.
8. After the hydraulic tank becomes dry, re-install the hydraulic tank cover and attach the suction hose and return hose to the hydraulic tank.
9. Add new hydraulic oil as needed.

## D-4 Replace Hydraulic Tank Suction Filter

Regularly replacing hydraulic tank suction filter is vital to good machine performance and extending service life. Dirty hydraulic oil may cause the machine to function improperly and continued use may result in hydraulic component damage. Extremely dirty condition requires the oil changes to be performed more frequently.

When performing the procedure [D-3 Replace Hydraulic Oil, page 5-23](#), the hydraulic tank suction filter must also be replaced.

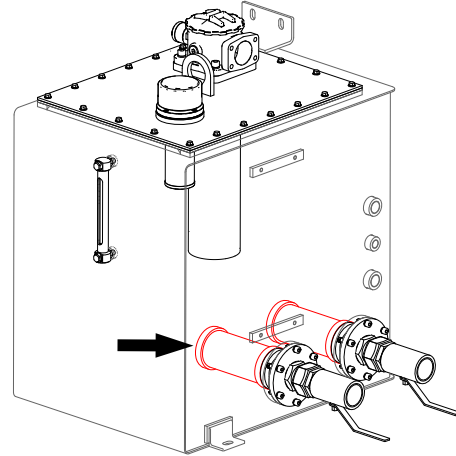
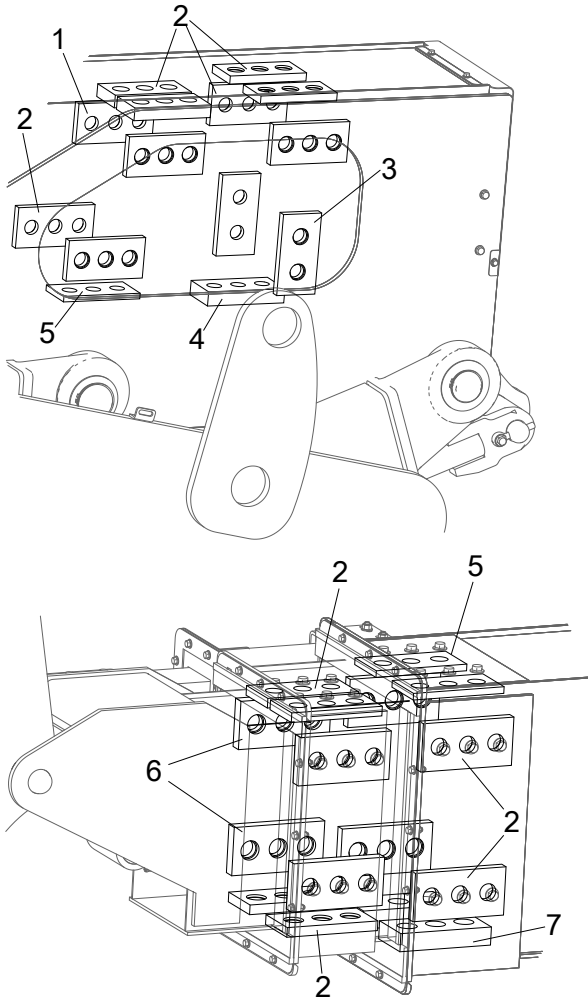


Figure 5-19

## D-5 Inspect Boom Wear Pads

Regularly inspecting the boom wear pads is vital to safe machine operation. Friction pair develops between each wear pad and the telescope boom surface. Improperly shimmed wear pads or continued use of extremely worn wear pads may result in component damage and unsafe operating conditions.



**Figure 5-20**

1. Remove the both boom end covers or nylon brush.
2. Measure the thickness of each wear pad as indicated in the above figure. The wear pad thickness specifications are listed in the table below.

**Table 5-12**

NO.	Thickness Specifications
1	16mm ( 0.63in )
2	25mm ( 0.98in )
3	16mm ( 0.63in )
4	28mm ( 1.10in )
5	11mm ( 0.43in )
6	20mm ( 0.79in )
7	30mm ( 1.18in )

3. When the wear extent of the wear pad is greater or equal to 3mm(0.118in.), the wear pad assembly should be timely replaced.

**NOTICE**

*The wear pad disassembled from the boom should never be reused. Be sure to replace with a new wear pad assembly.*

**This Page Intentionally Left Blank**

# 6 REPAIR PROCEDURES

## WARNING



**Repair procedures shall be completed by a person trained and qualified on the repair of this machine.**

**Immediately tag and remove from service a damaged or malfunctioning machine.**

**Repair any machine damage or malfunction before operating the machine.**

**Before machine startup :**

- **Read, understand and obey the safety rules and operating instructions contained in operation manual.**
- **Read all procedures and rules.**
- **Unless otherwise specified, perform each repair procedure with the machine in the following configuration:**
  - **Machine parked on a firm, level surface.**
  - **Platform in the stowed position.**
  - **Key switch in the OFF position with the key removed.**
  - **All wheels chocked.**

## BOOM AND PLATFORM COMPONENTS

### Boom and Platform Systems

#### Broken Cable Indicator System

The boom of this machine is a 3–section proportionally driven telescopic boom. The first telescopic boom is cylinder-driven, the second telescopic boom is driven by a separate wire rope system. Rope system contains redundant ropes that are capable of allowing the operator to continue use of the machine with a single rope failure. The retract cable is installed outside the boom so that the failures with retract cable are self-

revealing to the operator. Failures with the extend cable require the addition of the Broken Cable Indicator System in order to be self-revealing to the operator. This system uses a proximity sensor to detect excessive movement of the sensed rope as would be expected with a rope failure. A broken cable detection results in illuminating the indicator on the ground control display panel and triggering the alarm, and such functions as boom extending and raising are restricted while boom retracting and lowering is permitted. It is the responsibility of the operator to take the appropriate action.

#### Platform Control Enable System

The platform controls make use of a time dependent enable circuit to limit the time availability of “live” or enabled controls. When the footswitch is depressed, the controls are enabled and the operator has 7 seconds to operate any function. The controls will remain enabled as long as the operator continues to use any function and will remain enabled 7 seconds after the last function has been used. While the controls are “live”, the enabled light will be illuminated in the platform display panel. When the time limit has been reached, the enabled light will turn off and the controls will be “dead” or disabled. To continue use of the machine the controls must be re-enabled to start the timer system over again. This is done by releasing all functions, then releasing and re-depressing the footswitch.

#### Boom Position Sensing System

The boom position sensing system uses the boom angle sensor and boom length sensor mounted in the pivot end of base boom to indicate the boom position. The boom operating position is recognized when the angle sensor reads more than 15° with respect to gravity or the length sensor reads more than 1.2m extension, otherwise it indicates that the boom is in the non-operating position. The jib boom position is excluded from consideration.

This system is used to control the following systems :

- Drive Speed Cutback System
- Axle Extension System

#### Drive Speed Cutback System

When boom is positioned in operating position, the drive motors are automatically restricted to the operating speed mode.

## Platform Controller

**WARNING**

**ELECTROCUTION HAZARD**

**Before performing this procedure, be sure to disconnect the battery and the charger on AC outlet. Contact with live conductors may result in death or serious injury.**

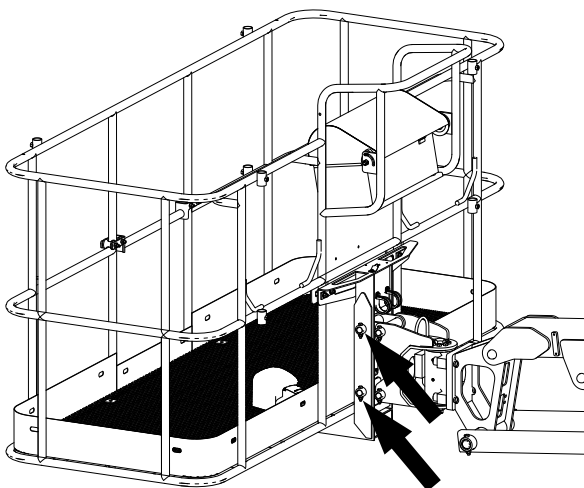
**NOTICE**

*Perform this procedure with the machine in stowed position.*

1. Disconnect external power supply, and push in the emergency stop buttons on the platform and ground controllers to OFF position.
2. Locate the cable connected to the bottom of the platform controller.
3. Disconnect and tag the cable from the bottom of the platform controller.
4. Remove the retaining bolts from the platform controller.
5. Remove the platform controller from the machine.

## Platform

1. Remove the platform controller from the platform. For the specific procedure, please reference [Platform Controller, page 6-2](#).
2. Remove the footswitch.
3. Support and secure the platform to an appropriate lifting device.
4. Remove the platform mounting bolts.



**Figure 6-1**

5. Use a brass drift or wooden hammer to tap the connecting pin out.
6. Slowly move the platform away with a lifting device.

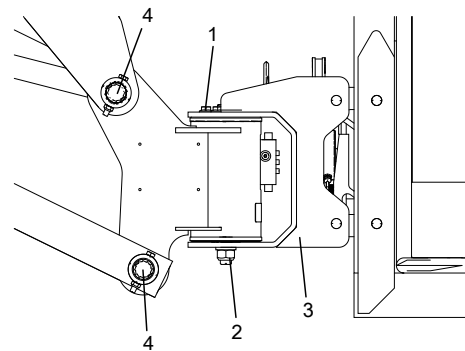
## Platform Rotate Motor

**NOTICE**

*Before re-installing the removed hoses and fittings, check whether the seals on the hoses and fittings are broken or missing; if any seal is damaged or missing, replace the seal with a new one, or replace the hose assembly and fittings directly. When installing hoses and fittings, tighten them according to the specified torque. See [Hydraulic Hose and Fitting Specifications, page 2-14](#).*

**Note :**


Platform rotate motor is used to drive the platform to rotate within the range of 160°.




**Figure 6-2**

1. Remove the platform.
2. Tag, disconnect and plug the hydraulic hoses from the both ports of platform rotate cylinder, and cap the fittings on the manifold.
3. Use a suitable device to support the platform rotate motor bracket 3#.
4. Remove the retaining bolts 1# and pivot pin 2#, and then remove the bracket 3#.
5. Use a suitable device to support the platform rotate motor.
6. Remove the bolts and nuts securing the pivot pin 4# to the platform rotate motor.
7. Remove the platform rotate motor.

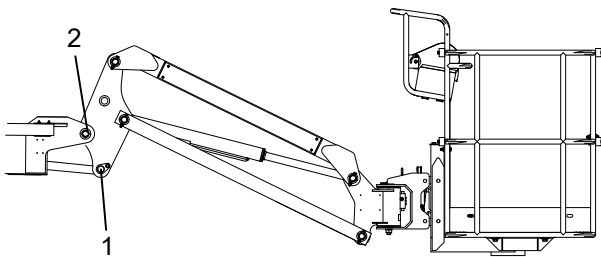
### Jib Boom Assembly (TB26EJ Plus&28EJ Plus only)


**WARNING**

**MOVING OBJECT HAZARD**



**Wear eye protection when tapping the brass drift with wooden hammer.**



**Figure 6-3**

#### Removing the jib boom assembly

**NOTICE**

*Before re-installing the removed hoses and fittings, check whether the seals on the hoses and fittings are broken or missing; if any seal is damaged or missing, replace the seal with a new one, or replace the hose assembly and fittings directly. When installing hoses and fittings, tighten them according to the specified torque. See [Hydraulic Hose and Fitting Specifications, page 2-14](#).*

1. Position the main boom horizontal, and attach the jib boom assembly to a suitable crane.
2. Use a suitable device to support the upper level cylinder.
3. Remove the fasteners at the pivot pin 1# of upper level cylinder, and drive the pivot pin 1# out using brass drift and wooden hammer.
4. Remove the fasteners at the pivot pin 2#, and drive the pivot pin 2# out using brass drift and wooden hammer.
5. Using the crane, slowly lift the jib boom assembly off the main boom.


#### Inspecting the jib boom assembly

**NOTICE**


*When inspecting the pins and bearings, please see [Pins and composite bearing, page 4-5](#).*

- Check the pivot pins for wear, scratch, deformation or other damages, and replace if needed.
- Check the inside of bearings for wear, scratch, deformation or other damages, and replace if needed.
- Check the jib lift cylinder connecting pins for wear, scratch, deformation or other damages. Before installation, ensure the pin surface is treated with protection. Replace if needed.
- Check the inside of the bearings connecting the platform rotate motor for wear, scratch, deformation or other damages, and replace if needed.
- Check all threaded parts for elongation, thread deformation, torsion or other damages, and replace if needed.
- Check all structures of jib boom assembly for deformation, cracks, weld detachment or other damages, and replace the jib boom if needed.

#### Platform Level Cylinder


**WARNING**

**MOVING OBJECT HAZARD**



**Wear eye protection when tapping the brass drift with wooden hammer.**

**NOTICE**

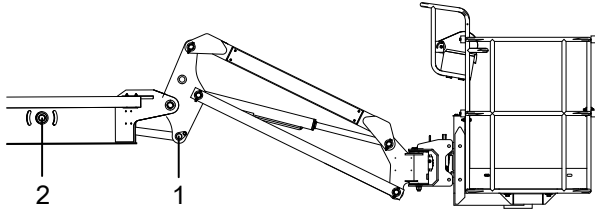
*When removing the cylinder, special care should be taken to avoid the fall of the cylinder and component damage.*

The machine is configured with 2 platform level cylinders located at the boom upper end and lower end.

The platform level cylinder is used for maintaining the platform level (in relation to the turntable) through the entire range of motion.

1. Extend the boom until the platform level cylinder rod-end pivot pin is accessible.
2. Slightly raise the boom and place a support under the platform.
3. Lower the boom until the platform sits on the support. Take special care not to press the total weight of boom over the support.

4. Disconnect and plug the hydraulic lines to the platform level cylinder.
5. Remove the retaining screw from the rod-end pivot pin #1 of the platform level cylinder. And do not move the pivot pin.



**Figure 6-4**

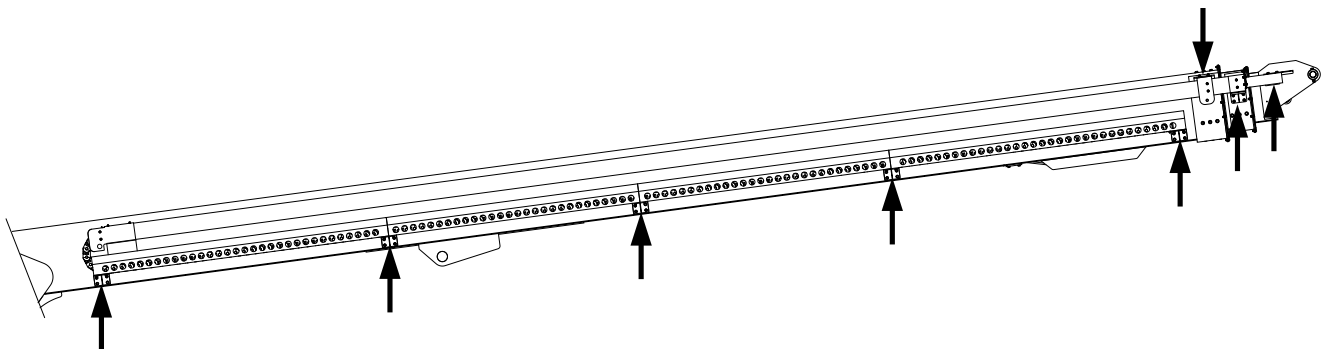
6. Remove the retaining ring from the pivot pin #2. And do not move the pivot pin.
7. Support the platform level cylinder with an appropriate supporting device to protect the piston rod from damage.

8. Use brass drift and wooden hammer to tap the pivot pin #1 out.
9. Use brass drift and wooden hammer to tap the pivot pin #2 out.
10. Carefully remove the cylinder from the boom.

## Cable Track Assembly

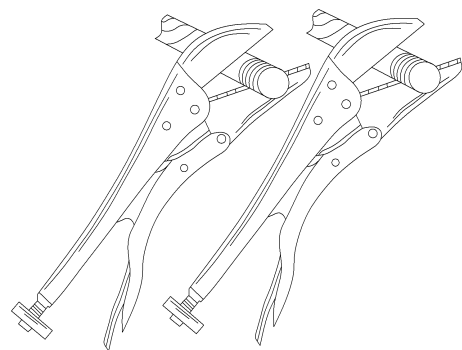
### NOTICE

*Before re-installing the removed hoses and fittings, check whether the seals on the hoses and fittings are broken or missing; if any seal is damaged or missing, replace the seal with a new one, or replace the hose assembly and fittings directly. When installing hoses and fittings, tighten them according to the specified torque. See [Hydraulic Hose and Fitting Specifications, page 2-14](#).*



**Figure 6-5**

1. Tag, disconnect and plug all hydraulic hoses and cables from cable track guide to the platform.
2. Remove the hydraulic hoses and cables from the cable track.
3. Using a suitable lifting device, fully support the cable track along the entire length.
4. Remove the bolts as indicated by the arrows in the above figure.
5. Using the lifting device, slowly move the cable track away from the boom.



**Figure 6-6**

## Steel Cable Tensioning Adjustment

1. Position the boom to horizontal and extend 1.5–1.8m (5ft-6ft).
2. Remove the lock nuts from the wire rope retainer.
3. Using a tool, hold the thread end (platform end) of the retract cable to prevent it from rotating.

### NOTICE

*Do not hold the wire rope on the thread.*

- Using a wrench, torque alternately the adjusting nuts of the both retract cables to 112 Nm (82.68 ft-lb).

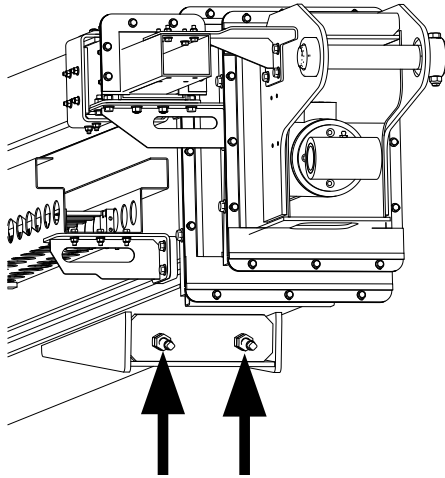


Figure 6-7

- Retract the boom to 0.6–0.9m (2ft-3ft) of boom extension.
- Using a tool, hold the thread end (turntable end) of the extend cable to prevent it from rotating.
- Using a wrench, torque alternately the adjusting nuts of the both extend cables to 112 Nm (82.68 ft-lb).

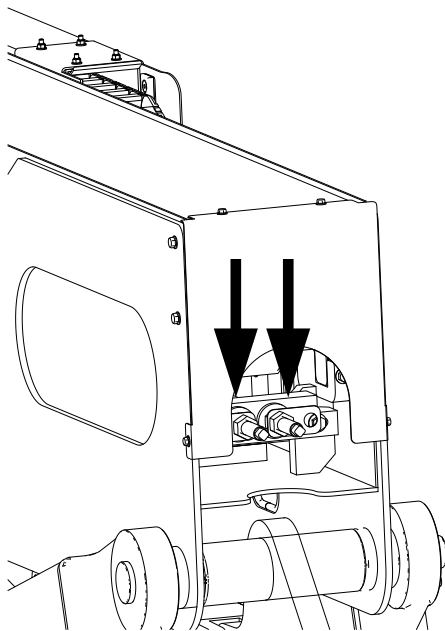


Figure 6-8

- Fully retract the boom, and ensure each boom section position dimensions fall within the tolerances in the figure below.

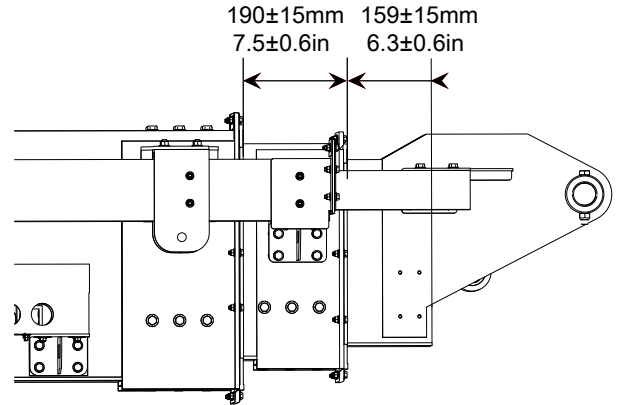


Figure 6-9

- Re-install the locknut to the steel cable retainer.
- Check each boom function operates properly.

Main Boom Assembly

**⚠ WARNING**

**MOVING OBJECT HAZARD**

**Wear eye protection when tapping the brass drift with a wooden hammer.**

**NOTICE**

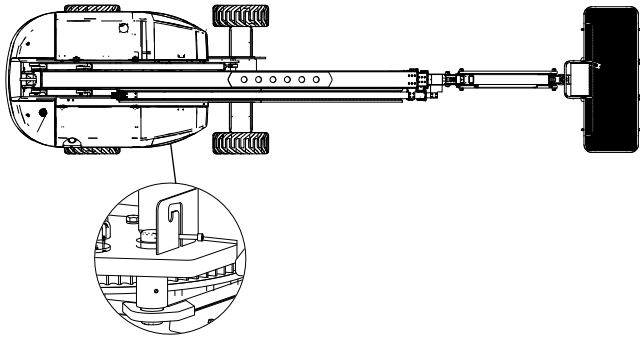
*Before re-installing the removed hoses and fittings, check whether the seals on the hoses and fittings are broken or missing; if any seal is damaged or missing, replace the seal with a new one, or replace the hose assembly and fittings directly. When installing hoses and fittings, tighten them according to the specified torque. See [Hydraulic Hose and Fitting Specifications, page 2-14](#).*

**⚠ WARNING**

**UNSAFE OPERATION HAZARD**

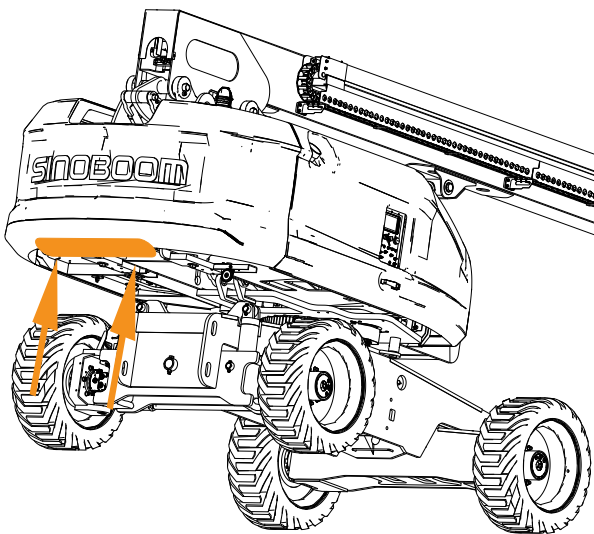
**Before removing the main boom assembly and lift cylinder, verify that:**

- The boom is positioned in the chassis drive direction, and the turntable lock pin is secured, as shown in [Fig 6-9, page 6-6](#).
- The counterweight is adequately supported by a rigid structure, as shown in [Fig 6-10, page 6-6](#).



**Figure 6-10**

5. Remove the retaining ring at the pivot pin #1 connecting the main boom lift cylinder with the boom.
6. Using a brass drift and wooden hammer, tap the pivot pin #1 out.
7. Using a suitable lifting device (capacity not less than 5t), secure the lifting straps to the bottom end of the main boom.
8. Remove the bolts and keeper pins of the pivot pins #2 and #3 connecting the boom assembly with the support arm.
9. Using a brass drift and wooden hammer, tap the pivot pins #2 and #3 out.
10. Using a lifting device, slowly lift the boom assembly off the turntable.



**Figure 6-11**

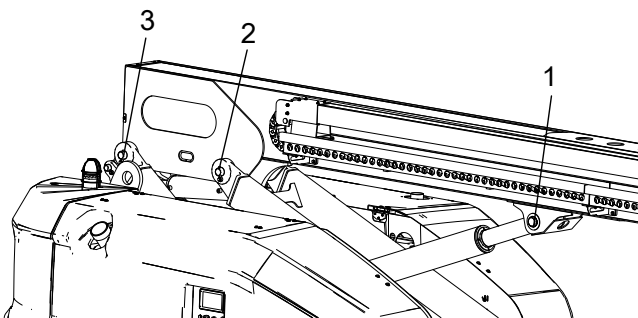
## CHASSIS AND TURNTABLE COMPONENTS

### Tires and Rims

#### Replacing tires and rims

Hunan Sinoboom Intelligent Equipment Co., Ltd. recommends that the replacement tires be of the same size, ply rating and brand as the original tires. For the part number of a specific machine model, please reference the Part Manual. If the replacement tires are not as Hunan Sinoboom Intelligent Equipment Co., Ltd. recommends, the following requirements of tires should be met:

1. Ply rating/rated load and dimension equal to or greater than original.
2. Tire tread contact width equal to or greater than original.
3. Wheel diameter, width and offset dimensions equal to the original.
4. Approved for the application by the tire manufacturer (including intended purposes, maximum drive speed and maximum tire load, etc.).
5. Due to size variations between different tire brands, both tires on the same axle should be of the same brand.



**Figure 6-12**

1. Slightly raise the boom until the main boom lift cylinder is accessible.
2. Tag, disconnect and plug the hydraulic hoses and cables to the boom assembly.
3. Using a suitable lifting device (capacity not less than 5t), secure the lifting straps to the main boom end.
4. Adequately support the main boom lift cylinder with a suitable supporting device.

**⚠ WARNING**

**UNSAFE OPERATION HAZARD**




The tires and rims installed on each product model have been designed for stability requirements. Size changes such as rim width, center piece location, diameter, etc., without written factory recommendations, may result in an unsafe condition regarding stability.

**Installing tires and rims**

It is extremely important to apply and maintain proper wheel mounting torque.

**⚠ WARNING**

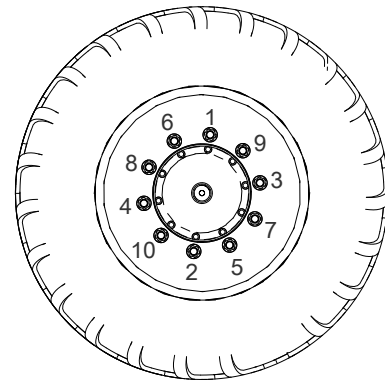
**UNSAFE OPERATION HAZARD**



- Use the wheel nuts that suit the rim bolts. The wheel nuts must be installed and maintained at the proper torque to prevent loose wheels, broken studs and possible dangerous separation of wheels from the axle. Be sure to only use the nuts matched to the cone angle of the wheel.
- Tighten the lug nuts to the proper torque to prevent wheels from coming loose. Use a torque wrench to tighten the fasteners. If you do not have a torque wrench, tighten the fasteners with a socket wrench, then immediately have a service garage or dealer tighten the lug nuts to the proper torque. Over-tightening will result in breaking the studs or permanently deforming the mounting stud holes in the wheels.

The proper procedure for attaching wheels is as follows:

1. First apply the threadlocker Loctite 272 to the nuts, then hand tighten all nuts to prevent the bolts and nuts becoming loose. Do not use a lubricant on threads or nuts.
2. Tighten the nuts in the sequence as shown below.



**Figure 6-13**

3. The tightening of the nuts should be done in stages. Following the recommended sequence, tighten nuts per wheel torque as listed in the table below.

**Table 6-1**

1st Stage	2nd Stage	3rd Stage
250Nm (185ft-lb)	550Nm (406ft-lb)	700Nm (517ft-lb)

**NOTICE**

*Wheel nuts should be torqued prior to first use of machine and after each wheel removal. Check torque every 3 months or 150 hours of operation.*

**Turntable Slewing Mechanism**

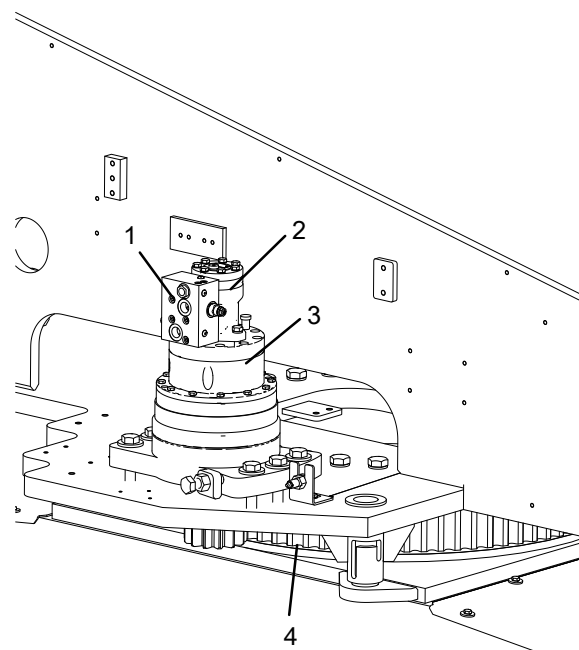


Figure 6-14

Table 6-2

NO.	DESCRIPTION
1	Slewing Buffer Valve
2	Slewing Motor
3	Slewing Reducer
4	Slewing Bearing

NO.	DESCRIPTION
9	Second Stage Planetary Gear Set Assembly (see <a href="#">Fig 6-17 Second Stage Planetary Gear Set Assembly, page 6-9</a> )
10	Screw
11	Mounting Disc
12	Screw

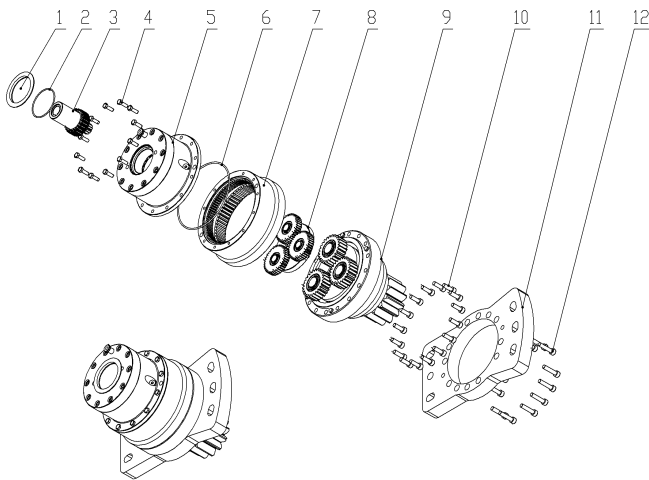


Figure 6-15 Slewing Reducer Assembly

Table 6-3

NO.	DESCRIPTION
1	Dust Cover
2	O-ring
3	Spline Sleeve
4	Bolt
5	Brake Assembly (see <a href="#">Fig 6-15 Brake Assembly, page 6-8</a> )
6	O-ring
7	Gear Ring
8	First Stage Planetary Gear Set Assembly (see <a href="#">Fig 6-16 First Stage Planetary Gear Set Assembly, page 6-9</a> )

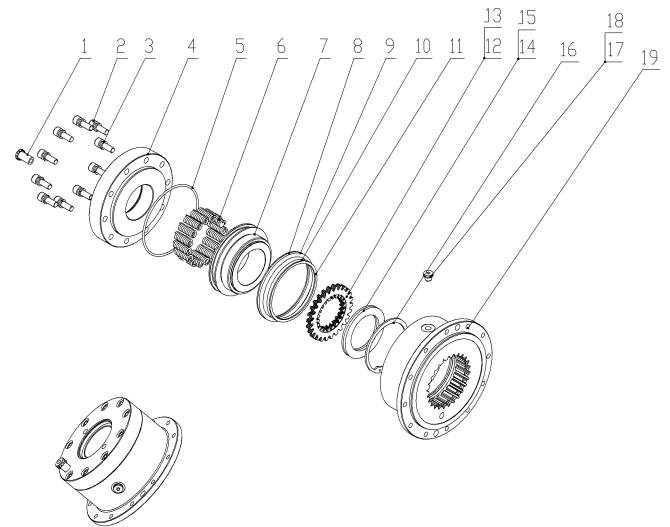
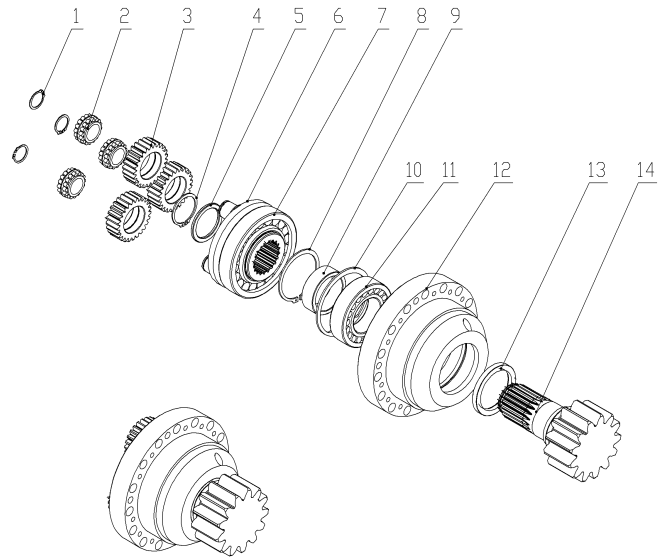


Figure 6-16 Brake Assembly

Table 6-4

NO.	DESCRIPTION
1	Breather Plug
2	Screw
3	Standard Spring Washer
4	Motor Seat
5	O-ring
6	Spring
7	Piston
8	O-ring
9	Retainer Ring
10	O-ring
11	Retainer Ring

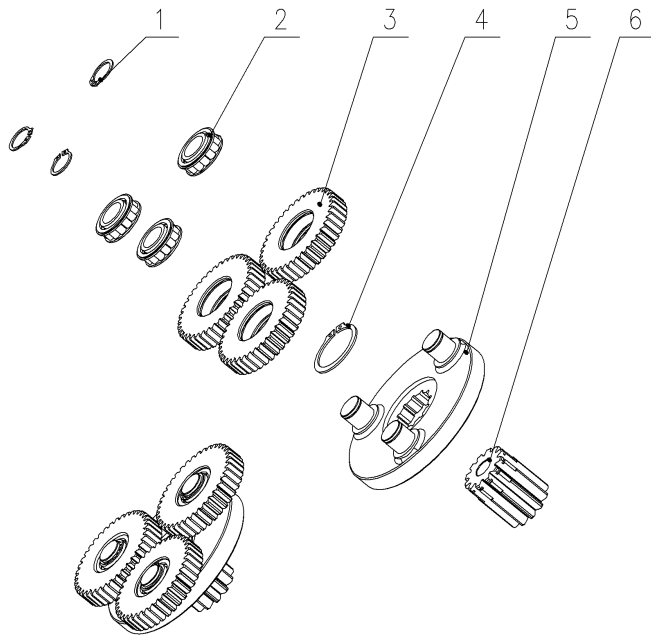
NO.	DESCRIPTION
12	Outer Friction Disc
13	Inner Friction Disc
14	Adjuster Shim
15	Backing Plate
16	Standard Retainer Ring for Hole
17	Thread Plug
18	Compound Gasket
19	Brake Housing



**Figure 6-18 Second Stage Planetary Gear Set Assembly**

**Table 6-6**

NO.	DESCRIPTION
1	Retainer Ring for Shaft
2	Bearing
3	Second Stage Planet Gear
4	Retainer Ring for Shaft
5	Gasket
6	Second Stage Planet Gear Carrier
7	Bearing
8	Retainer Ring for Shaft
9	Spacer Bush
10	Retainer Ring for Hole
11	Bearing
12	Bearing Seat
13	Oil Seal
14	Output Spline Shaft



**Figure 6-17 First Stage Planetary Gear Set Assembly**

**Table 6-5**

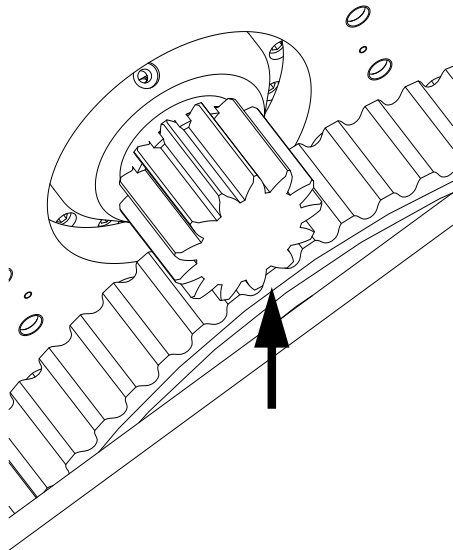
NO.	DESCRIPTION
1	Standard Retainer Ring for Shaft
2	Bearing
3	First Stage Planet Gear
4	Retainer Ring for Shaft
5	First Stage Planet Gear Carrier
6	Second Stage Sun Gear

**Removal of slewing drive device**

1. Tag, disconnect and plug the hydraulic hoses of slewing buffer valve and slewing reducer brake.
2. Remove the bolt and washer from the slewing buffer valve, and then remove the slewing buffer valve from the slewing motor.
3. Remove the bolts securing the slewing reducer to the turntable, and then remove the slewing reducer.

### Installation of slewing drive device

1. Clear the foreign matters and burrs on the mounting surface and gears of slewing reducer.
2. Place the slewing reducer on the turntable mounting surface, use a feeler gauge to measure the gear backlash relative to the slewing bearing, be sure the gear backlash falls within 0.15—0.25mm (0.006—0.01in).

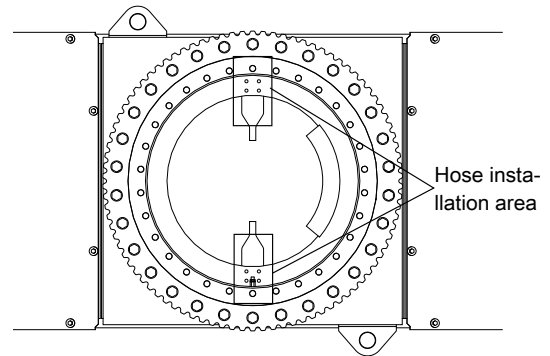


**Figure 6-19**

3. If the gear backlash exceeds the specification, adjust the nut to specification.
4. With washer on the bolt, apply threadlocker Loctite 272. Install the mounting bolts to secure the slewing reducer to the turntable, after installation pre-tighten in diagonal order.
5. Ensure the slewing reducer fits in well with the turntable.
6. Use a wrench to tighten the bolts in diagonal order.
7. Add gear oil to the slewing reducer until the gear surface is covered.
8. Clean the mounting surface of slewing reducer, and mate the axis pin of slewing motor with the reducer pin hole.
9. Rotate the motor housing to align the slewing motor bolt hole with the reducer bolt hole. Apply threadlocker Loctite 272 to the bolt with washer on, install the bolt and tighten.

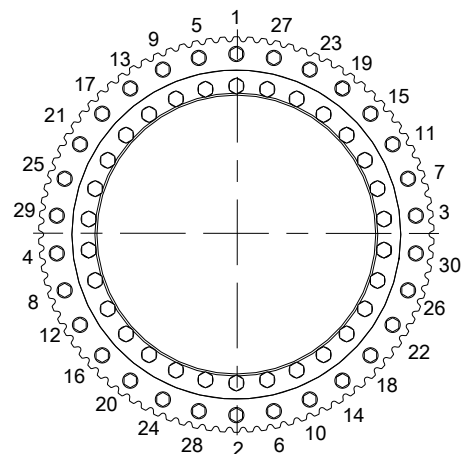
### Installation of slewing bearing

1. Use a lifting device with sufficient capacity to lift the slewing bearing over the mounting surface of chassis.
2. Ensure the soft strap intallation area of the slewing bearing is vertical to the boom direction.



**Figure 6-20**

3. Use a feeler gauge to measure the clearance between the mounting surface of the slewing bearing and that of the chassis, ensure the clearance  $\leq 0.2\text{mm}$  (0.008in).
4. Using the special washer for the high-strength bolt, mate the washer surface with the mounting surface, apply threadlocker Loctite 272 to the bolt, and intall the bolts one by one.
5. Tighten the bolts in the sequence as shown in the figure below.



**Figure 6-21**

6. The tightening of bolts should be done in stages, Follow the stages and the recommended torques as listed in the table below to tighten the bolts.

Table 6-7

1st Stage	2nd Stage	3rd Stage
180Nm (133ft-lb)	360Nm (266ft-lb)	600Nm (443ft-lb)

7. Hand turn the inner ring of the slewing bearing, ensure it moves smoothly.
8. Detach the lifting device from the slewing bearing.
9. Rotate the inner ring of the slewing bearing until the soft strap area on the inner ring and that on the outer ring are symmetrically arranged around the center of the slewing bearing.
10. Using a lifting device, lift the turntable to the mounting surface of the slewing bearing.
11. Using the special washer for the high-strength bolt, mate the washer surface with the mounting surface, apply threadlocker Loctite 272 to the bolt, and install the bolts one by one.
12. Refer to [Fig 6-20 , page 6-10](#) , and tighten the retaining bolts in the sequence as indicated.
13. Refer to [Table 6-7 , page 6-11](#) , and tighten the bolts per the recommended torques and sequence.

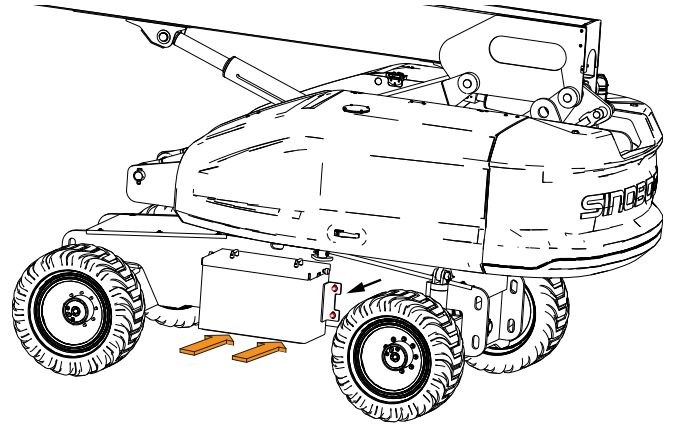


Figure 6-22

1. Locate the battery box on the chassis side.
2. Tag and disconnect the wiring to the battery.
3. Place the fork arms of a forklift under the battery box to be removed ( as indicated by the yellow arrows in the [Fig 6-21 , page 6-11](#) ) for support.
4. Remove the bolts from both sides of the battery box.
5. Slowly lower the fork arms to move the battery box clear of the chassis.

Battery Box

**⚠ WARNING**

ELECTROCUTION HAZARD

- Before removing the battery, cut off the power to the charger and machine.
- Contact with hot circuit may cause serious injury or death. Be sure to wear goggles, gloves and protective clothing.
- Remove all rings, watches and other jewelry.

The machine is equipped with two battery boxes, located on both sides of the chassis.

Battery

**⚠ WARNING**

ELECTROCUTION HAZARD

- Before removing the battery, cut off the power to the charger and machine.
- Contact with hot circuit may cause serious injury or death. Be sure to wear goggles, gloves and protective clothing.
- Remove all rings, watches and other jewelry.

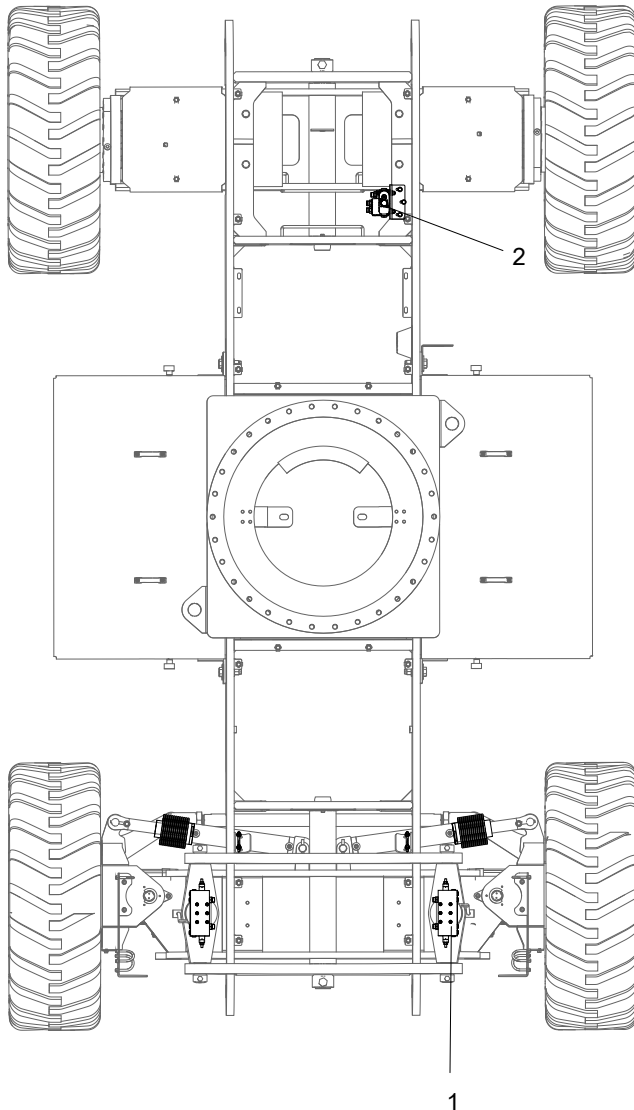
The battery is installed at 2 locations, inside the battery boxes on both sides of chassis and inside the right turntable cover.

**Battery on the right side of turntable :**

1. Open the right turntable cover and locate the battery.
2. Tag and disconnect the battery cables.
3. With assistance of a lifting device, remove the battery.

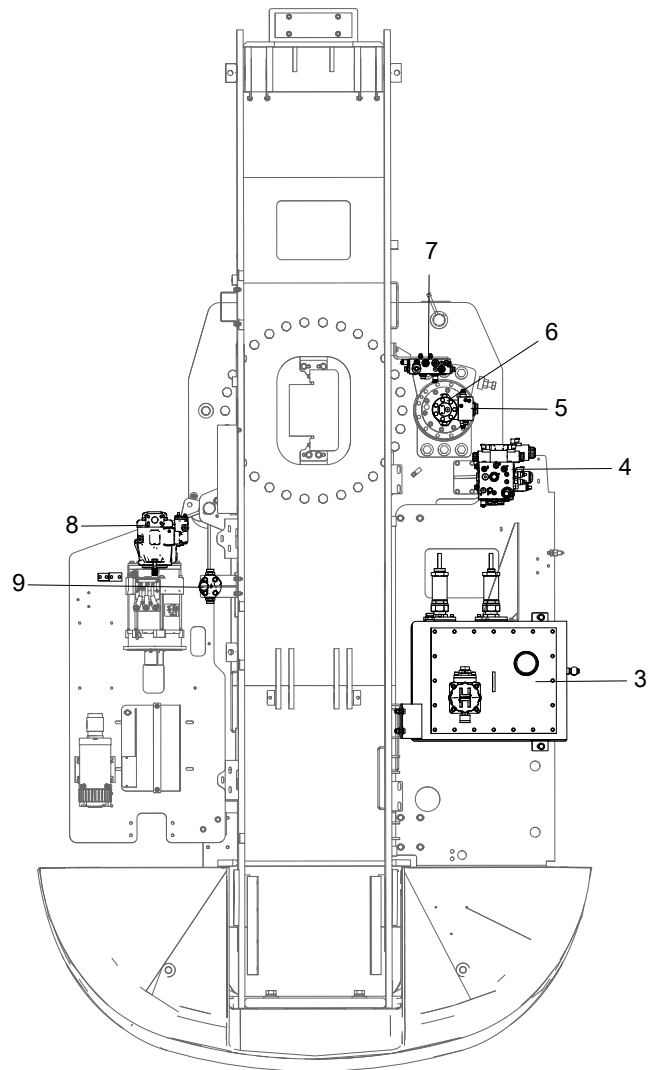
## Battery on both sides of chassis :

1. Remove the battery box. For the details, see [Battery Box, page 6-11](#).
2. With assistance of a lifting device, remove the battery.



## HYDRAULIC SYSTEM

### Layout of Hydraulic Elements



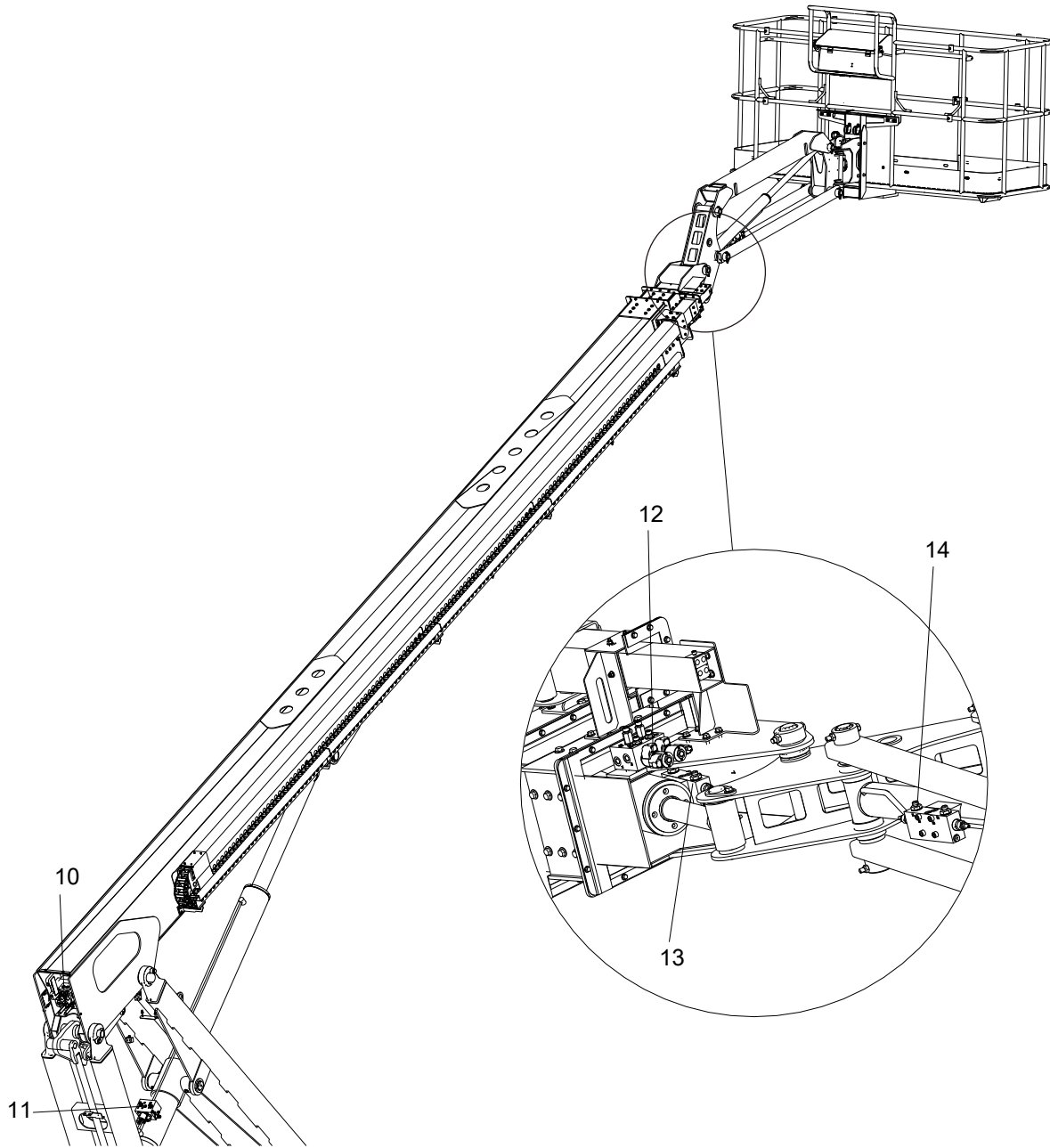
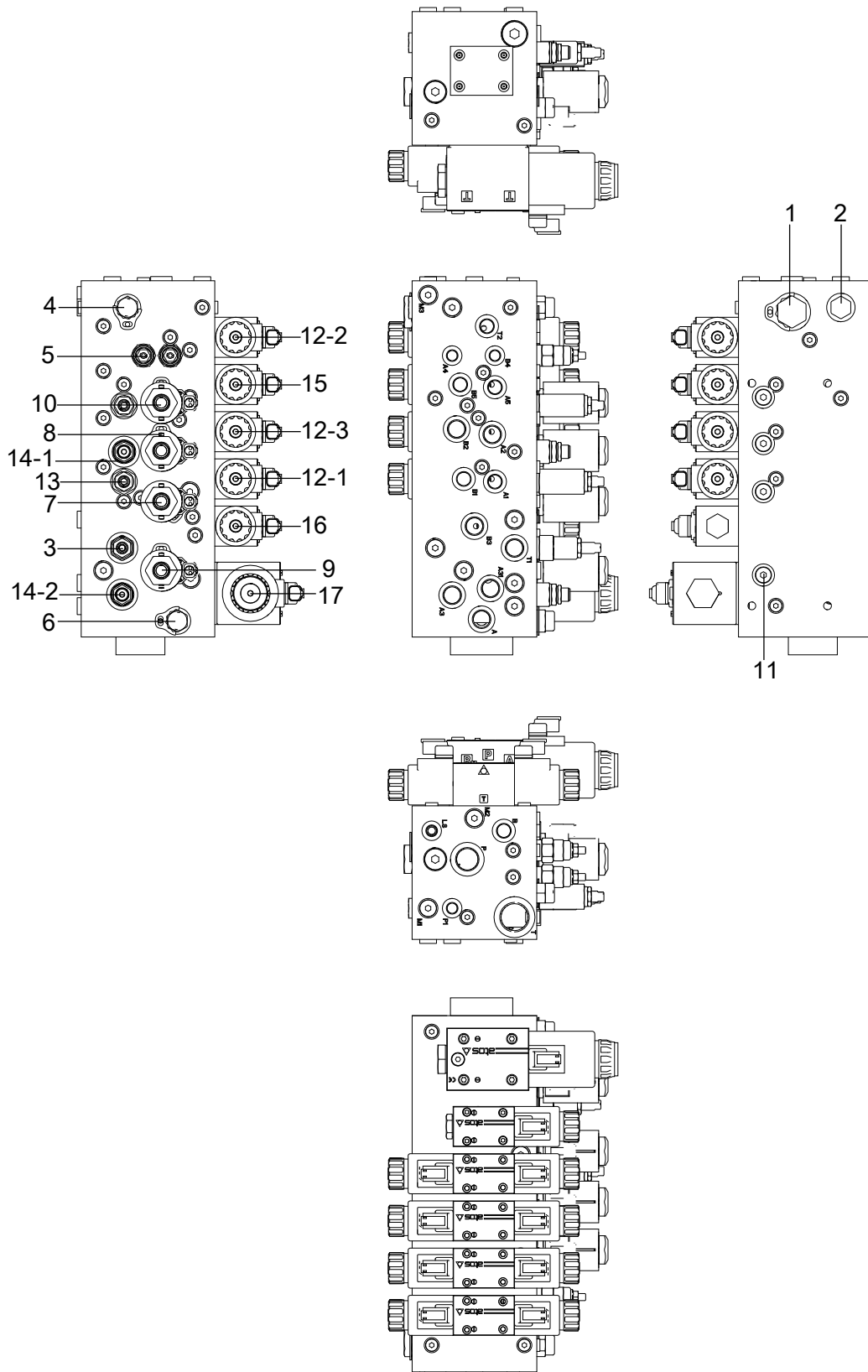


Figure 6-23

Table 6-8

1. Oscillate counterbalance valve	6. Cycloid motor	11. Lift control valve
2. Oscillate multi-way valve	7. Oscillate control valve	12. Level counterbalance valve
3. Hydraulic tank	8. Open-circuit variable displacement pump	13. Platform duplex valve
4. Boom function manifold	8.High-pressure filter	14. Level counterbalance valve
5. Slewing buffer valve	10. Telescope counterbalance valve	

## Function Manifold

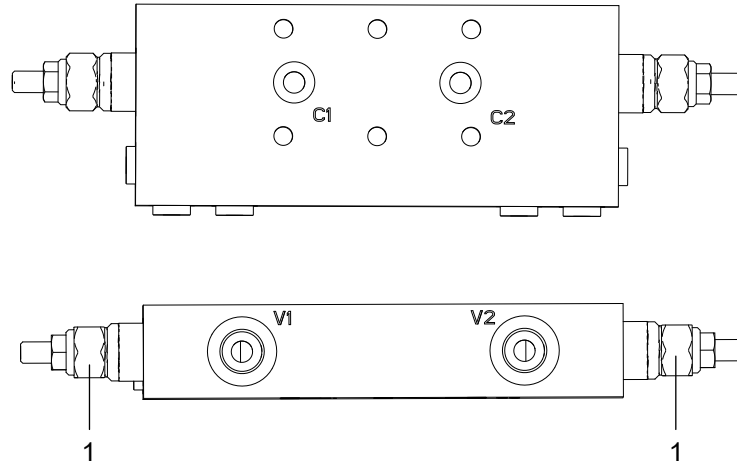


**Figure 6-24 boom function manifold (PN.202040003176)**

**Table 6-9 boom function manifold (PN.202040003176)**

NO.	NAME	TORQUE	FUNCTION
1	Check valve	85–95Nm (63–70ft-lb)	Keep fluid flowing in one way
2	Check valve	40–45Nm (30–33ft-lb)	Keep fluid flowing in one way
3	Relief valve	33.9Nm (25ft-lb)	Control system pressure
4	Compensator valve	27.1Nm (20ft-lb)	Release power unit pressure
5	Damper	5Nm (3.7ft-lb)	\
6	Flow valve	27.1Nm (20ft-lb)	Release LS feedback pressure
7	Solenoid directional valve	36.7Nm (27ft-lb)	Control turntable slewing
8	Solenoid directional valve	40.6Nm (30ft-lb)	Control boom lifting\lowering
9	Solenoid directional valve	40.6Nm (30ft-lb)	Control boom telescoping
10	Solenoid directional valve	36.7Nm (27ft-lb)	Control platform leveling
11	Check valve	26–28Nm (19–21ft-lb)	Keep fluid flowing in one way
12	6-way Y-type gate valve	8Nm (6ft-lb)	Control the direction of turntable slewing, boom luffing and platform leveling
13	Relief valve	25.8–28.5Nm (19–21ft-lb)	Control steering pressure
14	Relief valve	55–65Nm (41–48ft-lb)	Control lowering and boom extending pressure
15	6-way O-type gate valve	8Nm (6ft-lb)	Control steer direction
16	6-way solenoid valve	8Nm (6ft-lb)	Control boom telescoping direction
17	10-way solenoid valve	15Nm (11ft-lb)	Control boom telescoping direction
18	Counterbalance valve	34–41Nm (25–30ft-lb)	Maintain a balanced load
19	Bolt	15Nm (11ft-lb)	\
20	Cover plate	\	\
21	Coil	14Nm (10ft-lb)	\
22	Plug	11–12Nm (8–9ft-lb)	\
23	Plug	25–28Nm (18–21ft-lb)	\
24	Plug	41–48Nm (30–35ft-lb)	\
25	Plug	72–82Nm (51–61ft-lb)	\
26	Bolt	8Nm (6ft-lb)	\

NO.	NAME	TORQUE	FUNCTION
27	Bolt	15Nm (11ft-lb)	\
28	Damper	5Nm (3.7ft-lb)	\



**Figure 6-25 202040003032 oscillate counterbalance valve**

**Table 6-10 202040003032 oscillate counterbalance valve**

NO.	NAME	TORQUE	FUNCTION
1	Counterbalance valve	40 ~ 45Nm (30 ~ 33ft-lb)	Keep the load balanced

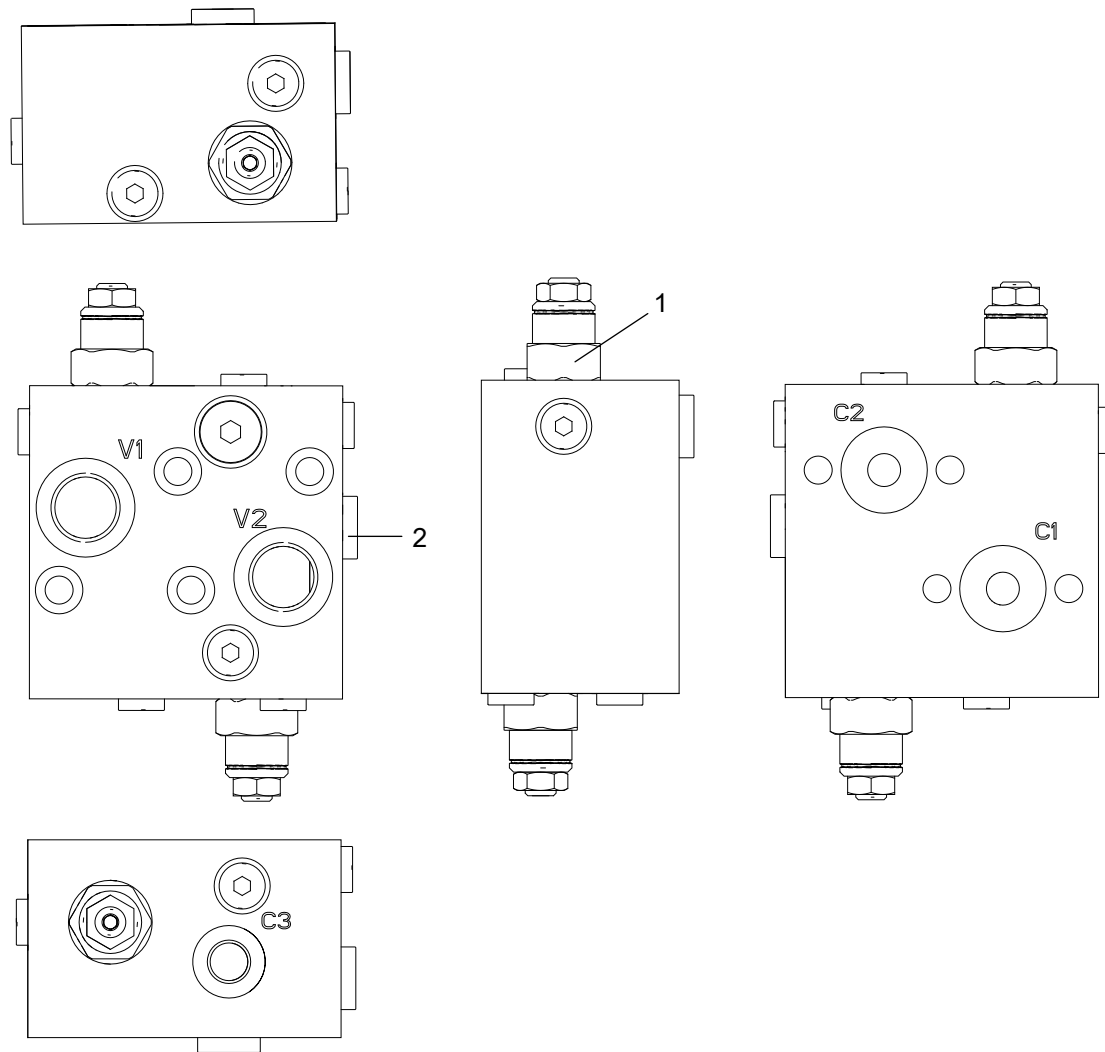


Figure 6-26 202040003061 slewing buffer valve

Table 6-11 202040003061 slewing buffer valve

NO.	NAME	TORQUE	FUNCTION
1	Counterbalance valve	40 ~ 45Nm (30 ~ 33ft-lb)	Keep the load balanced
2	Shuttle valve	\	Circuit switchover

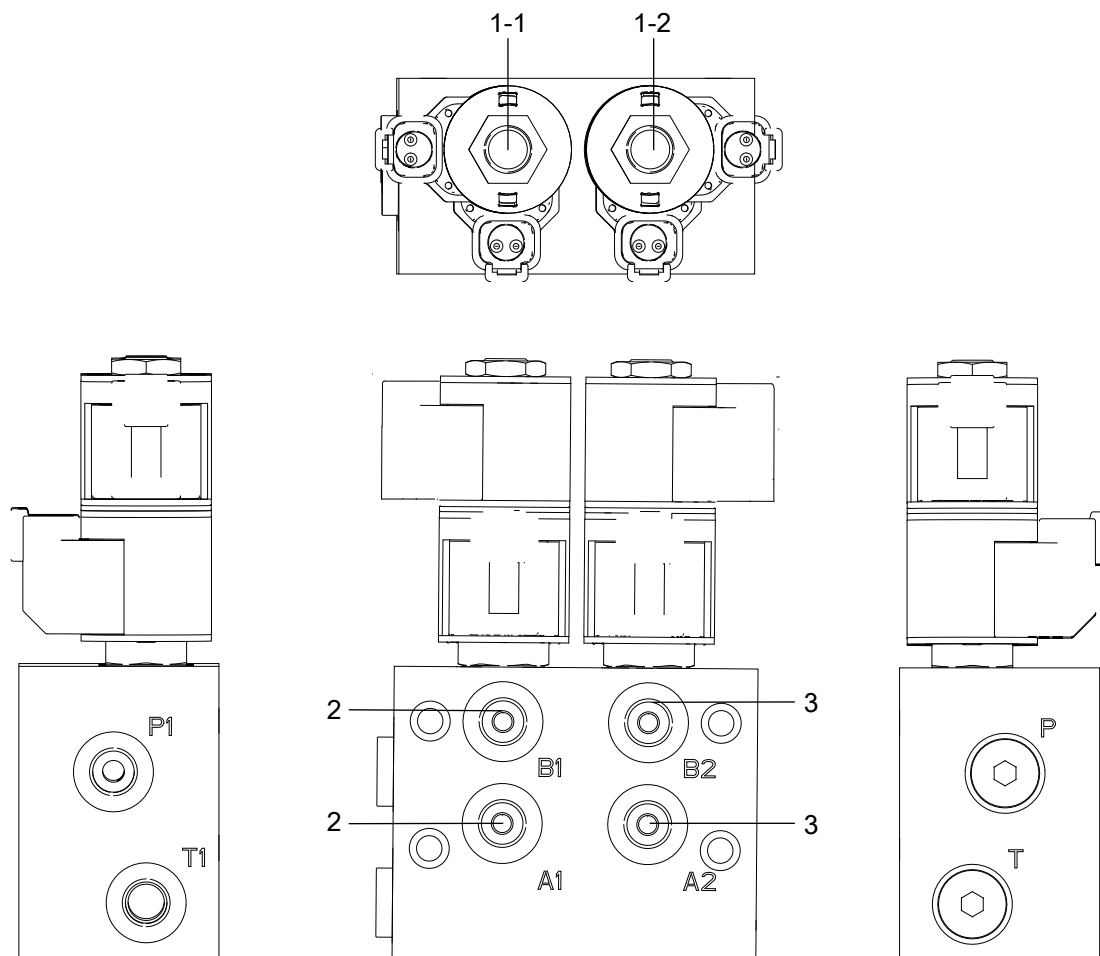


Figure 6-27 202040000329 platform duplex valve

Table 6-12 202040000329 platform duplex valve

NO.	NAME	TORQUE	FUNCTION
1-1	Solenoid valve	40 ~ 45Nm (30 ~ 33ft-lb)	Jib boom lift direction and speed control
1-2	Solenoid valve	40 ~ 45Nm (30 ~ 33ft-lb)	Platform rotation direction and speed control
2	Damper	5Nm (9ft-lb)	\
3	Damper	5Nm (9ft-lb)	\

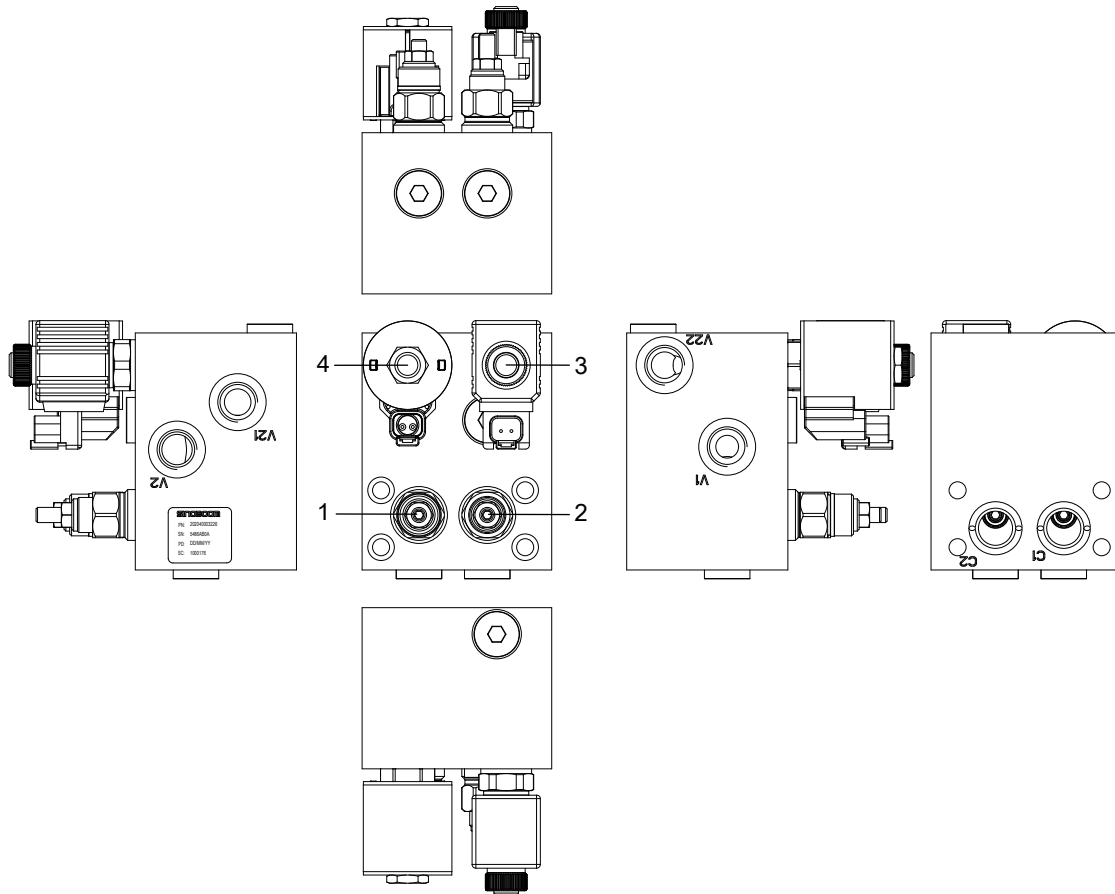


Figure 6-28 Telescope control valve (PN.202040003226)

Table 6-13 Telescope control valve (PN.202040003226)

NO.	NAME	TORQUE	FUNCTION
1	Counterbalance valve	41 ~ 47Nm (30 ~ 35ft-lb)	Maintain a balanced load
2	Counterbalance valve	41 ~ 47Nm (30 ~ 35ft-lb)	Maintain a balanced load
3	Solenoid valve	40Nm (29.5ft-lb)	Maintain a balanced load
4	Solenoid valve	45–50Nm (33–37ft-lb)	Control the speed of boom extending/retracting

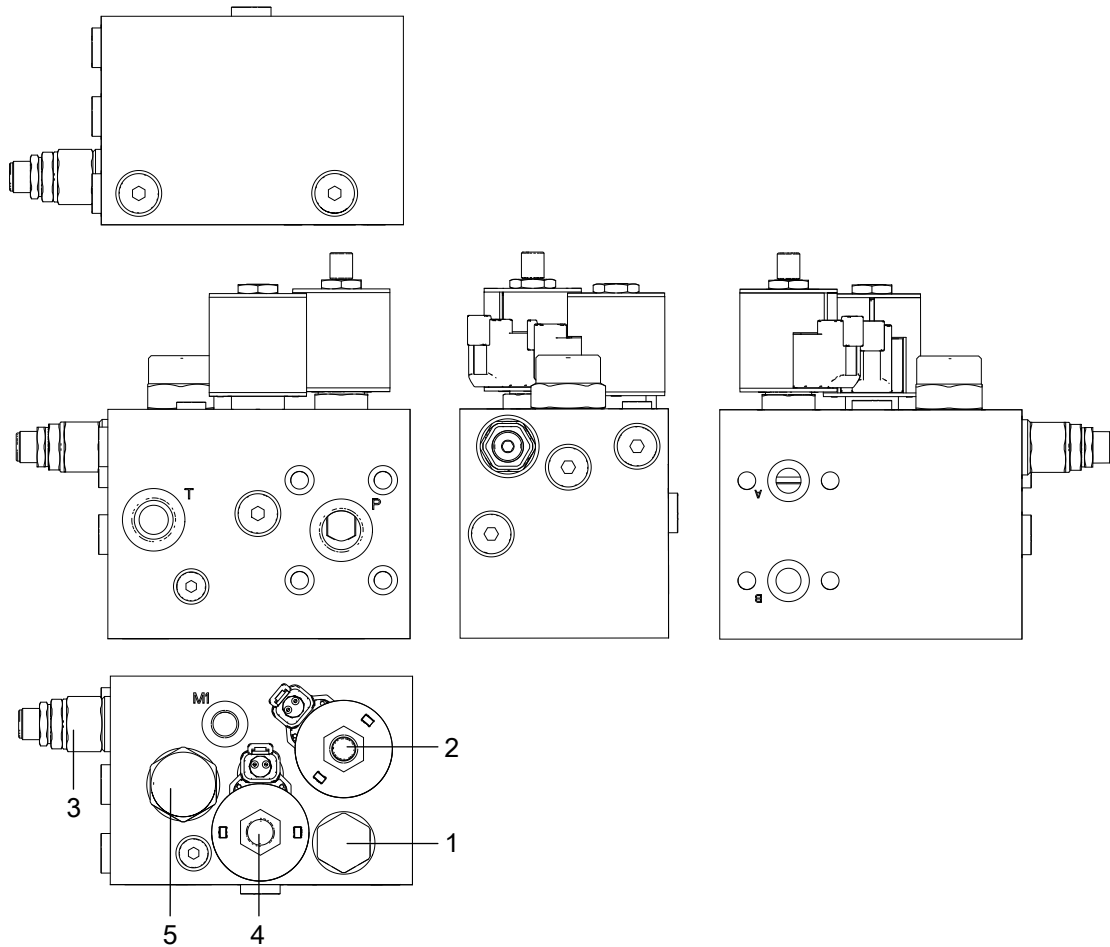


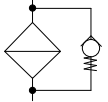
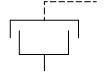
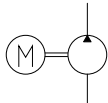

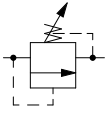
Figure 6-29 Luffing control valve (PN.202040003227)

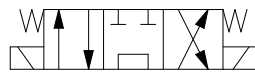
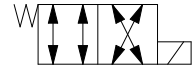
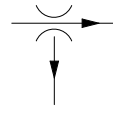

Table 6-14 Luffing control valve (PN.202040003227)

NO.	NAME	TORQUE	FUNCTION
1	Check valve	55–65Nm (41–48ft-lb)	Keep fluid flowing in one way
2	Solenoid valve	32.5–35.3Nm (24–26ft-lb)	Maintain a balanced load
3	Relief valve	55–65Nm (41–48ft-lb)	Provide overload protection
4	Proportional solenoid valve	44.9–50.3Nm (33.1–37.1ft-lb)	Control main boom lifting/lowering speed
5	Compensator valve	40.6Nm (30ft-lb)	Provide flow compensation

## Hydraulic Symbols

**Table 6-15**

Symbol	Description
	Filter
	Brake
	Emergency power
	Hydraulic motor
	Overflow valve

Symbol	Description
	3-position 4-way solenoid directional valve
	2-position 4-way solenoid directional valve
	Pressure gradient control valve
	Check valve

Hydraulic Schematic

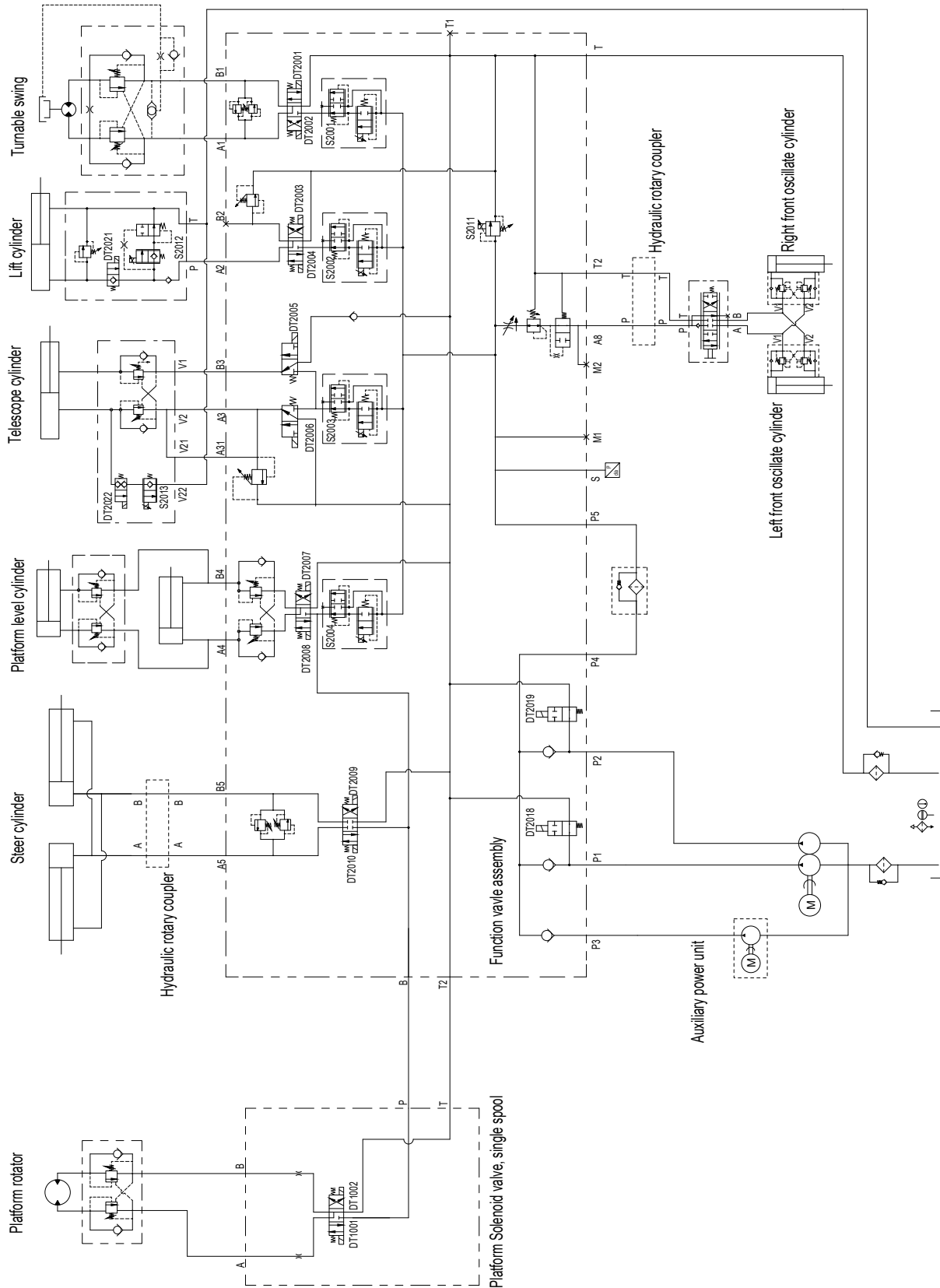


Figure 6-30 Hydraulic schematic-TB24E Plus

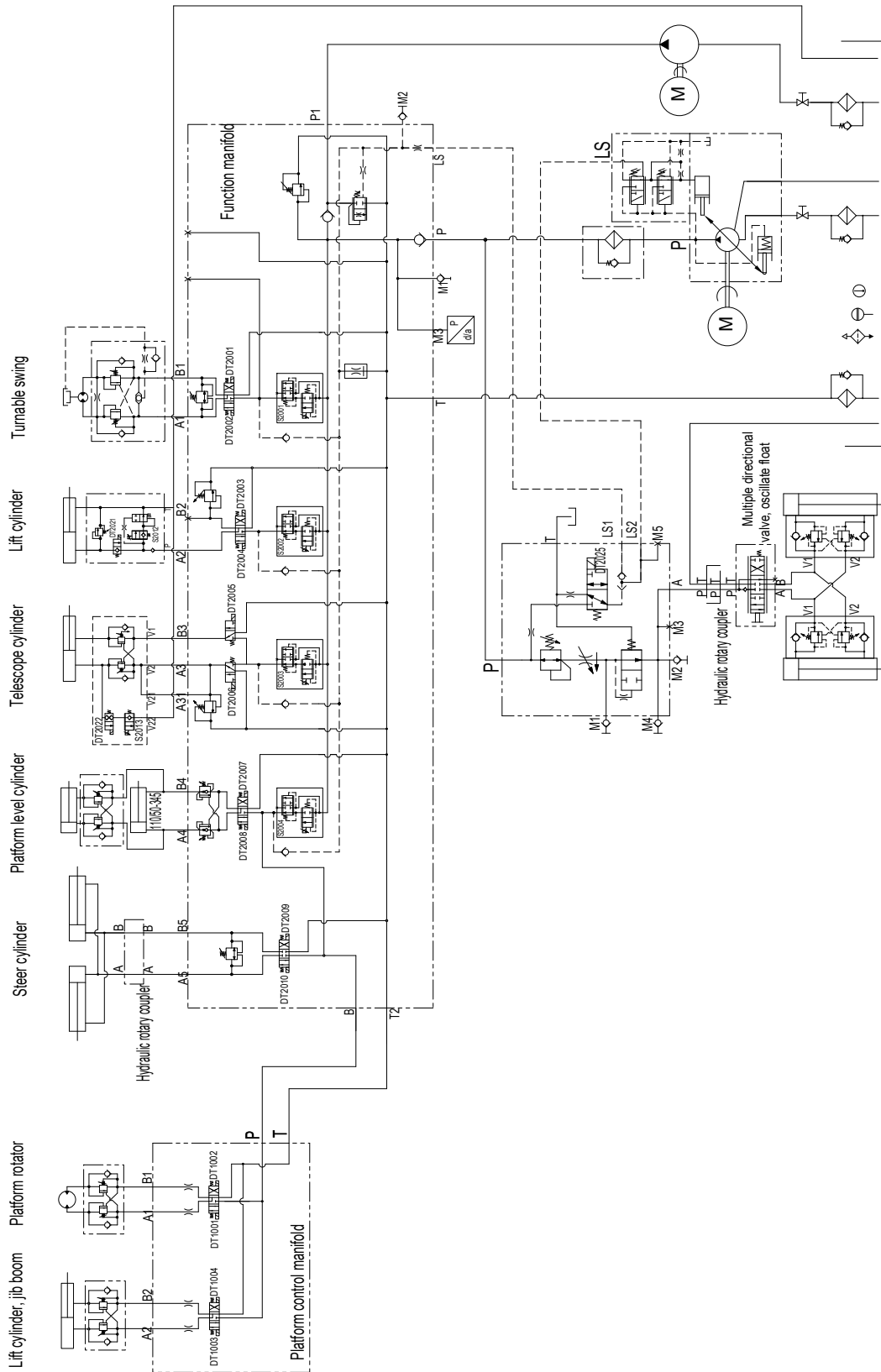


Figure 6-31 Hydraulic schematic-TB26EJ Plus

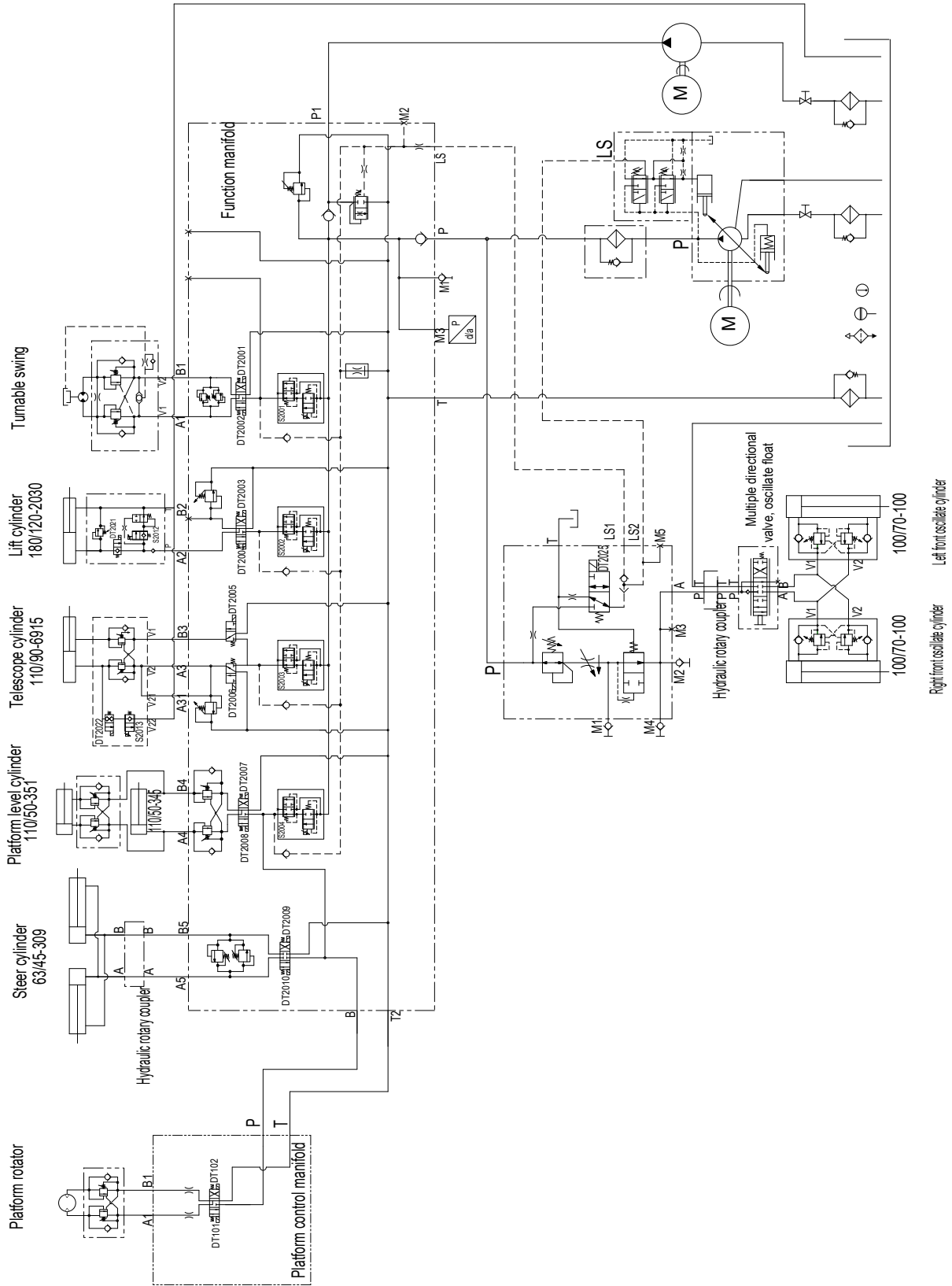


Figure 6-32 Hydraulic schematic-TB26E Plus

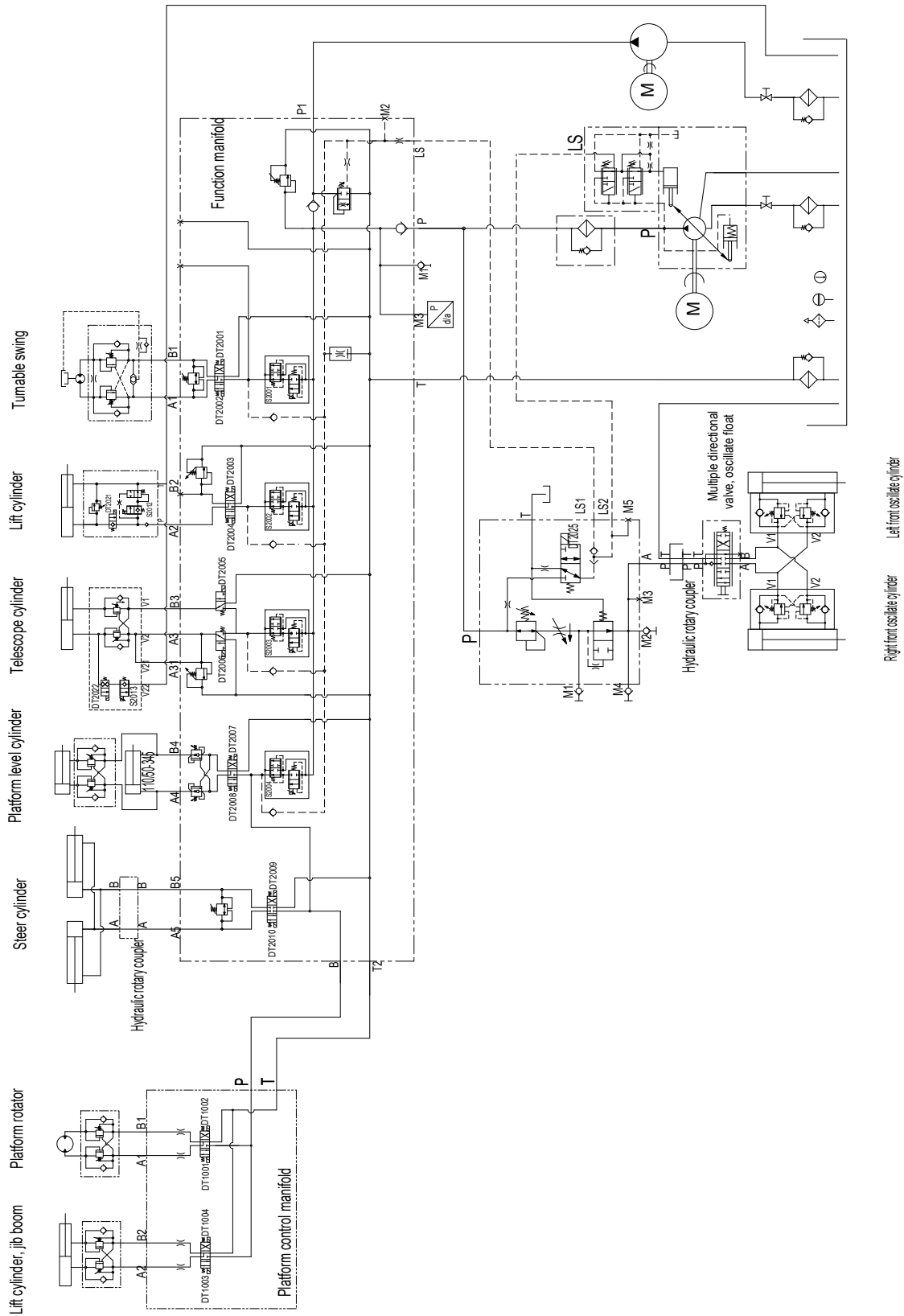


Figure 6-33 Hydraulic schematic-28EJ Plus

## ELECTRICAL SYSTEM

## Fault Code Description

In case of machine malfunctions, please enter the fault display interface on the ground controller to check the fault codes.

Table 6-16 Machine fault code description

Fault Code	Description	Cause	Solution
01	Platform communication fault	Abnormal communication between platform and ground controllers	Check the signal lines between platform and ground controllers, and ensure the power supply is normal.
02	Drive controller communication fault	Abnormal communication between driver and ground controllers	Check the signal lines between ground and drive controllers, and ensure the power supply is normal.
03	Turntable tilt alarm	Turntable tilt alarm	Check whether the machine tilts exceeding 5° or the level switch becomes disconnected
04	Overload alarm	Overload alarm	Check whether the platform load exceeds the rating.
05	Weighing sensor fault	Weighing sensor fault	Check whether the Weighing sensor functions properly.
06	Drive joystick error	Drive joystick data error	Check the drive joystick data
07	Steer joystick error	Steer joystick data error	Check the steer joystick data
08	Main boom luffing joystick error	Main boom luffing joystick data error	Check the Main boom luffing joystick data
09	Slewing joystick error	Slewing joystick data error	Check the slewing joystick data
10	Telescoping joystick error	Telescoping joystick data error	Check the Telescoping joystick data
11	Jib rotation joystick error	Jib rotation joystick data error	Check the jib rotation joystick data
12	Hydraulic system pressure sensor error	Hydraulic system pressure sensor error	Check whether the hydraulic system pressure sensor functions properly
13	Level switch fault	Level switch fault	Check whether the level switch functions properly
14	Lift controller communication fault	Lift controller communication fault	Check the signal lines between platform and drive controllers, and ensure the power supply is normal.
15	Footswitch or Enable switch 7-second limit alarm	Footswitch or Enable switch 7-second limit alarm	Check whether the footswitch or enable switch function properly
16	Obstacle detection alarm	Obstacle detection alarm	Check whether the obstacle detection switch functions properly
17	Drive controller error alarm	Drive controller error alarm	Check the associated error of drive controller

Fault Code	Description	Cause	Solution
18	Lift controller error alarm	Lift controller error alarm	Check the associated error of lift controller
19	Heavy load alarm	Heavy load alarm	Check the platform load and the actual measurement of sensor AD value
20	Envelope alarm	Envelope alarm	Check the boom position and the actual measurement of sensor AD value
21	Broken rope alarm	Broken rope alarm	Check the wire ropes of boom and the wiring of proximity switch
22	Weighing sensor comparison error	Weighing sensor comparison error	Check the weighing sensor actual values and AD value, and check the wiring
23	Platform tilt alarm	Platform tilt alarm	Check whether the platform tilt angle out of range
24	Solenoid clutch fault	Solenoid clutch fault	Check whether the solenoid clutch functions properly or the wiring harness is disconnected
25	Turntable slewing left solenoid valve error	Turntable slewing left solenoid valve error	Check the wiring of turntable slewing left solenoid valve
26	Turntable slewing right solenoid valve fault	Turntable slewing right solenoid valve fault	Check the wiring of turntable slewing right solenoid valve
27	Main boom extending solenoid valve fault	Main boom extending solenoid valve fault	Check the wiring of main boom extending solenoid valve
28	Main boom retracting solenoid valve fault	Main boom retracting solenoid valve fault	Check the wiring of main boom retracting solenoid valve
29	Main boom lifting solenoid valve fault	Main boom lifting solenoid valve fault	Check the wiring of main boom lifting solenoid valve
30	Main boom lowering solenoid valve error	Main boom lowering solenoid valve error	Check the wiring of main boom lowering solenoid valve
31	Articulated boom lifting solenoid valve fault	Articulated boom lifting solenoid valve fault	Check the wiring of articulated boom lifting solenoid valve
32	Articulated boom lowering solenoid valve fault	Articulated boom lowering solenoid valve fault	Check the wiring of articulated boom lowering solenoid valve
33	Steer left solenoid valve fault	Steer left solenoid valve fault	Check the wiring of steer left solenoid valve
34	Steer right solenoid valve fault	Steer right solenoid valve fault	Check the wiring of steer right solenoid valve
35	Platform swing left solenoid valve fault	Platform swing left solenoid valve fault	Check the wiring of platform swing left solenoid valve
36	Platform swing right solenoid valve fault	Platform swing right solenoid valve fault	Check the wiring of platform swing right solenoid valve
37	Platform leveling up solenoid valve fault	Platform leveling up solenoid valve fault	Check the wiring of platform leveling up solenoid valve

Fault Code	Description	Cause	Solution
38	Platform leveling down solenoid valve fault	Platform leveling down solenoid valve fault	Check the wiring of platform leveling down solenoid valve
39	Jib up solenoid valve fault	Jib up solenoid valve fault	Check the wiring of jib up solenoid valve
40	Jib down solenoid valve fault	Jib down solenoid valve fault	Check the wiring of jib down solenoid valve
41	Function enable valve fault	Function enable valve fault	Check the wiring of function enable valve
42	Main boom anti-fall valve fault	Main boom anti-fall valve fault	Check the wiring of main boom anti-fall valve
43	Drive enable valve fault	Drive enable valve fault	Check the wiring of drive enable valve
44	Brake valve fault	Brake valve fault	Check the wiring of brake valve
45	Slewing enable valve fault	Slewing enable valve fault	Check the wiring of slewing enable valve
46	Front pump unloading valve fault	Front pump unloading valve fault	Check the wiring of front pump unloading valve
47	Rear pump unloading valve fault	Rear pump unloading valve fault	Check the wiring of rear pump unloading valve
48	Electrically proportional relief valve fault	Electrically proportional relief valve fault	Check the wiring of electrically proportional relief valve
49	Articulated boom angle sensor comparison error	Articulated boom angle sensor comparison error	Check whether the articulated boom angle sensor is correctly installed
50	Articulated boom angle sensor fault	Articulated boom angle sensor fault	Check the wiring of articulated boom angle sensor
51	Main boom angle sensor comparison error	Main boom angle sensor comparison error	Check whether the main boom angle sensor is correctly installed
52	Main boom angle sensor fault	Main boom angle sensor fault	Check the wiring of main boom angle sensor
53	Articulated boom relative angle sensor comparison error	Articulated boom relative angle sensor comparison error	Check whether the articulated boom relative angle sensor is correctly installed
54	Articulated boom relative angle sensor fault	Articulated boom relative angle sensor fault	Check the wiring of articulated boom relative angle sensor
55	Main boom relative angle sensor comparison error	Main boom relative angle sensor comparison error	Check whether the main boom relative angle sensor is correctly installed
56	Main boom relative angle sensor fault	Main boom relative angle sensor fault	Check the wiring of main boom relative angle sensor

Fault Code	Description	Cause	Solution
57	Low battery level alarm	Low battery level alarm	Check whether the battery voltage is too low
58	Front right steer sensor fault	Front right steer sensor fault	Check the wiring of front right steer sensor
59	Clutch fault	Clutch fault	Check whether the clutch can be properly engaged or the sensor is correctly wired.
60	Low fuel level fault	Low fuel level fault	Check whether the fuel level is too low or the sensor is correctly wired.

**Table 6-17 General fault code description for electric motor controller**

Fault code	Description	Cause	Solution
0012	Overcurrent of pump motor	<ol style="list-style-type: none"> <li>1. Encoder fault or circuit interference;</li> <li>2. Motor UVW short-circuited;</li> <li>3. Mismatched motor parameters;</li> <li>4. Controller fault.</li> </ol>	<ol style="list-style-type: none"> <li>1. Check the encoder surface for stains, replace it if necessary;</li> <li>2. Check whether the 3-phase of motor UVW is shorted or damaged, check the controller UVW 3-phase for damage using a multimeter;</li> <li>3. Monitor the controller current when fully loaded, re-match the motor if necessary;</li> <li>4. If no problem is found in the above inspections, replace the controller.</li> </ol>
0112	Overcurrent of FL motor controller		
0212	Overcurrent of FR motor controller		
0312	Overcurrent of RL motor controller		
0412	Overcurrent of RR motor controller		
0013	Current sensor fault of pump motor controller	<ol style="list-style-type: none"> <li>1. Motor UVW short-circuited;</li> <li>2. Current sensor of the controller faulted.</li> </ol>	<ol style="list-style-type: none"> <li>1. Check the 3-phase cable of UVW for short circuit or current leakage;</li> <li>2. If no problem is found in the above inspections, replace the controller.</li> </ol>
0113	Current sensor fault of FL motor controller		
0213	Current sensor fault of FR motor controller		
0313	Current sensor fault of RL motor controller		
0413	Current sensor fault of RR motor controller		
0014	Pre-charging fault of pump motor controller	<ol style="list-style-type: none"> <li>1. The voltage is lowered due to loads connected to B+ circuit;</li> <li>2. Controller damage.</li> </ol>	<ol style="list-style-type: none"> <li>1. Check whether the controller B+ circuit is linked to high-power load;</li> <li>2. Check the KSI wiring, and measure the voltage using a multimeter to check if it is normal;</li> <li>3. If no problem is found in the above inspections, replace the controller.</li> </ol>
0114	Pre-charging fault of FL motor controller		
0214	Pre-charging fault of FR motor controller		
0314	Pre-charging fault of RL motor controller		
0414	Pre-charging fault of RR motor controller		

Fault code	Description	Cause	Solution
0015	Low temperature of pump motor controller	The controller operates at ambient temperatures below -40 °C.	<ol style="list-style-type: none"> <li>1. Raise the ambient temperature above -40 °C, restart the key switch and interlock switch;</li> <li>2. If no problem is found in the above inspection, replace the controller.</li> </ol>
0115	Low temperature of FL motor controller		
0215	Low temperature of FR motor controller		
0315	Low temperature of RL motor controller		
0415	Low temperature of RR motor controller		
0016	High temperature of pump motor controller	<ol style="list-style-type: none"> <li>1. Controller temperature over 95°C;</li> <li>2. Machine overload and motor mismatch;</li> <li>3. Controller damage.</li> </ol>	<ol style="list-style-type: none"> <li>1. Check the cooling measures of controller;</li> <li>2. Monitor the operating current of controller, re-match the motor if the current is too large, reset the turning point and slip value, properly restrict the current if needed.</li> <li>3. If no problem is found in the above inspections, replace the controller.</li> </ol>
0116	High temperature of FL motor controller		
0216	High temperature of FR motor controller		
0316	High temperature of RL motor controller		
0416	High temperature of RR motor controller		
0017	Severe undervoltage of pump motor controller	<ol style="list-style-type: none"> <li>1. Battery data setup error;</li> <li>2. Excessive battery resistance;</li> <li>3. Damaged fuse;</li> <li>4. Damaged main contactor.</li> </ol>	<ol style="list-style-type: none"> <li>1. Measure the battery voltage and KSI and B+ circuits voltage with a multimeter;</li> <li>2. Check the fuse and contactor;</li> <li>3. Check the battery setup, system voltage and undervoltage setting.</li> <li>4. If the drive controller fails, main contactor not engaged, the pump controller will report the fault 1.7.</li> </ol>
0117	Severe undervoltage of FL motor controller		
0217	Severe undervoltage of FR motor controller		
0317	Severe undervoltage of RL motor controller		
0417	Severe undervoltage of RR motor controller		
0018	Severe overvoltage of pump motor controller	<ol style="list-style-type: none"> <li>1. Battery setup error;</li> <li>2. Excessive battery resistance;</li> <li>3. Battery is disconnected when regenerative brake engages.</li> </ol>	<ol style="list-style-type: none"> <li>1. Check the battery with a multimeter for proper voltage;</li> <li>2. Check the fuse and contactor;</li> <li>3. Check the battery setup, system voltage and undervoltage setting.</li> <li>4. Check the regenerative brake setup and current limit.</li> </ol>
0118	Severe overvoltage of FL motor controller		
0218	Severe overvoltage of FR motor controller		
0318	Severe overvoltage of RL motor controller		
0418	Severe overvoltage of RR motor controller		
0021	Declined battery current of pump motor controller	Activated battery current attenuation	The power generation current limit value sent by the host computer is less than the actual value.
0121	Declined battery current of FL motor controller		

Fault code	Description	Cause	Solution
0221	Declined battery current of FR motor controller		
0321	Declined battery current of RL motor controller		
0421	Declined battery current of RR motor controller		
0022	Reduced over-temperature performance of pump motor controller	The controller operates at hostile environment with the radiator blade temperature higher than 85°C	<ol style="list-style-type: none"> <li>1. Use the machine under normal operating conditions to increase the cooling effect of controller.</li> <li>2. If the ambient temperature is normal, check the controller current which may cause an abrupt rise in temperature if too large.</li> </ol>
0122	Reduced over-temperature performance of FL motor controller		
0222	Reduced over-temperature performance of FR motor controller		
0322	Reduced over-temperature performance of RL motor controller		
0422	Reduced over-temperature performance of RR motor controller		
0023	Reduced undervoltage performance of pump motor controller	<ol style="list-style-type: none"> <li>1. Low battery level;</li> <li>2. Battery setup error;</li> <li>3. Battery aging</li> </ol>	<ol style="list-style-type: none"> <li>1. Check the battery with a multimeter for proper voltage;</li> <li>2. Check the fuse and contactor;</li> <li>3. Check the battery setup, system voltage and undervoltage setting.</li> </ol>
0123	Reduced undervoltage performance of FL motor controller		
0223	Reduced undervoltage performance of FR motor controller		
0323	Reduced undervoltage performance of RL motor controller		
0423	Reduced undervoltage performance of RR motor controller		
0024	Reduced overvoltage performance of pump motor controller	<ol style="list-style-type: none"> <li>1. Battery setup error;</li> <li>2. Regenerative brake current results in voltage increase.</li> </ol>	<ol style="list-style-type: none"> <li>1. Check the battery with a multimeter for proper voltage;</li> <li>2. Check the fuse and contactor;</li> <li>3. Check the battery setup, system voltage and undervoltage setting.</li> <li>4. Check the regenerative brake setup and current limit.</li> </ol>
0124	Reduced overvoltage performance of FL motor controller		
0224	Reduced overvoltage performance of FR motor controller		
0324	Reduced overvoltage performance of RL motor controller		

Fault code	Description	Cause	Solution
0424	Reduced overvoltage performance of RR motor controller		
0025	Invalid 5V internal power supply of pump motor controller	Externally connected device fault	<ol style="list-style-type: none"> <li>1. Check the externally connected device for damage;</li> <li>2. Using handhold unit check monitor/outputs menu/5 Volts;</li> <li>3. Disconnect externally connected 5V devices, if the fault still exists, replace the external devices.</li> </ol> <p>Note: The pin #26 of the 35-pin controller connector is for 5V output.</p>
0125	Invalid 5V internal power supply of FL motor controller		
0225	Invalid 5V internal power supply of FR motor controller		
0325	Invalid 5V internal power supply of RL motor controller		
0425	Invalid 5V internal power supply of RR motor controller		
0026	Driver 6 output error of pump motor controller	Externally connected device fault	<ol style="list-style-type: none"> <li>1. Using handhold unit, check monitor/digital out6 to find out the driver 6 signal output percentage;</li> <li>2. Check the drive device of driver 6 for malfunctions, correct wiring, and current not exceeding 1A.</li> </ol> <p>Note: The pin #19 of the 35-pin controller connector is for drive 6 output.</p>
0126	Driver 6 output error of FL motor controller		
0226	Driver 6 output error of FR motor controller		
0326	Driver 6 output error of RL motor controller		
0426	Driver 6 output error of RR motor controller		
0027	Driver 7 output overcurrent of pump motor controller	Externally connected device fault	<ol style="list-style-type: none"> <li>1. Using handhold unit check monitor/digital out7, to inspect the driver 7 signal output percentage;</li> <li>2. Check the drive device of driver 7 for malfunctions, correct wiring, and current not exceeding 1A.</li> </ol> <p>Note: The pin #20 of the 35-pin controller connector is for driver 7 output.</p>
0127	Driver 7 output overcurrent of FL motor controller		
0227	Driver 7 output overcurrent of FR motor controller		
0327	Driver 7 output overcurrent of RL motor controller		
0427	Driver 7 output overcurrent of RR motor controller		
0028	Reduced overheat performance of pump motor controller	<ol style="list-style-type: none"> <li>1. Motor temperature reaching the preset limit;</li> <li>2. Improper set up motor temperature.</li> </ol>	<ol style="list-style-type: none"> <li>1. Check the motor temperature sensor for damage;</li> <li>2. Check the motor temperature setup of controller for error; and check programme/motor menu/temperature control temperature hot for overheat performance deceleration value setup;</li> <li>3. Monitor the machine operating current to determine whether the overheat results</li> </ol>
0128	Reduced overheat performance of FL motor controller		
0228	Reduced overheat performance of FR motor controller		

Fault code	Description	Cause	Solution
0328	Reduced overheat performance of RL motor controller		from an excessively high current, re-match the motor if necessary.
0428	Reduced overheat performance of RR motor controller		Note: The pins #7 and #8 of the 35-pin controller connector are for motor temperature sensor.
0029	Temperature sensor fault of pump motor controller	<ol style="list-style-type: none"> <li>Motor temperature sensor fault;</li> <li>Setup error of motor temperature sensor type.</li> </ol>	<ol style="list-style-type: none"> <li>Check the wiring of motor temperature sensor;</li> <li>Check the setup of motor temperature sensor via programme/motor menu/temperature control sensor type.</li> <li>Replace the motor temperature sensor.</li> </ol> <p>Note: The pins #7 and #8 of the 35-pin controller connector are for motor temperature sensor.</p>
0129	Temperature sensor fault of FL motor controller		
0229	Temperature sensor fault of FR motor controller		
0329	Temperature sensor fault of RL motor controller		
0429	Temperature sensor fault of RR motor controller		
0031	Open/short-circuited drive 1 output/main contactor of pump motor controller	<ol style="list-style-type: none"> <li>Driver 1 wiring fault;</li> <li>Loading device fault;</li> <li>Contactor fault.</li> </ol>	<ol style="list-style-type: none"> <li>Check if the wiring is correct and pins are stained or damaged;</li> <li>Monitor output signal via monitor menu/outputs menu/Driver 1 PWM to check whether there is output control signal;</li> <li>Check the coil of contactor;</li> <li>Replace the contactor.</li> </ol> <p>Note: The pins #6 of the 35-pin controller connector is for driver 1 output.</p>
0131	Open/short-circuited driver 1 output/main contactor of FL motor controller		
0231	Open/short-circuited driver 1 output/main contactor of FR motor controller		
0331	Open/short-circuited driver 1 output/main contactor of RL motor controller		
0431	Open/short-circuited driver 1 output/main contactor of RR motor controller		
0032	Open/short-circuited driver 2 of pump motor controller	<ol style="list-style-type: none"> <li>Drive 2 wiring fault;</li> <li>Loading device fault;</li> <li>Contactor fault.</li> </ol>	<ol style="list-style-type: none"> <li>Check if the wiring is correct and pins are stained or damaged;</li> <li>Monitor output signal via monitor menu/outputs menu/Driver 2PWM to check whether there is output control signal;</li> <li>Check the coil of contactor;</li> <li>Replace the contactor.</li> </ol> <p>Note: The pins #5 of the 35-pin controller connector is for driver 2 output.</p>
0132	Open/short-circuited driver 2 of FL motor controller		
0232	Open/short-circuited driver 2 of FR motor controller		
0332	Open/short-circuited driver 2 of RL motor controller		
0432	Open/short-circuited driver 2 of RR motor controller		
0033	Open/short-circuited solenoid brake/coil 3 output of pump motor controller	<ol style="list-style-type: none"> <li>Open/short circuited coil of solenoid brake;</li> <li>Stained/damaged/ broken wiring.</li> </ol>	<ol style="list-style-type: none"> <li>Check if the wiring is correct and pins are stained or damaged;</li> <li>Monitor output signal via monitor menu/outputs menu/Driver 3 PWM to check whether there is output control signal;</li> <li>Check the coil of contactor;</li> </ol>
0133	Open/short-circuited solenoid brake/coil 3		

Fault code	Description	Cause	Solution
	output of FL motor controller		4. Replace the solenoid brake.
0233	Open/short-circuited solenoid brake/coil 3 output of FR motor controller		
0333	Open/short-circuited solenoid brake/coil 3 output of RL motor controller		Note: The pins #4 of the 35-pin controller connector is for driver 3 output.
0433	Open/short-circuited solenoid brake/coil 3 output of RR motor controller		
0034	Open/short-circuited coil 4 output of pump motor controller		
0134	Open/short-circuited coil 4 output of FL motor controller		
0234	Open/short-circuited coil 4 output of FR motor controller	1. Open/short-circuited coil 4;	1. Check if the wiring is correct and pins are stained or damaged;
0334	Open/short-circuited coil 4 output of RL motor controller	2. Stained/damaged/ broken wiring.	2. Monitor output signal via monitor menu/ outputs menu/Driver 4PWM to check whether there is output control signal;
0434	Open/short-circuited coil 4 output of RR motor controller		3. Check the driver coil.
0035	Proportional drive error of pump motor controller		
0135	Proportional drive error of FL motor controller	1. Open/short-circuited loading device;	1. Check if the wiring is correct and pins are stained or damaged;
0235	Proportional drive error of FR motor controller	2. Stained/damaged/ broken wiring;	2. Monitor output signal via monitor menu/ outputs menu/PD PWM to check whether there is output control signal;
0335	Proportional drive error of RL motor controller	3. Improper wiring.	3. Check the loading devices, such as the driver coil, for damage.
0435	Proportional drive error of RR motor controller		
0036	Encoder error of pump motor controller		1. Check the encoder power supply;
0136	Encoder error of FL motor controller	1. Failed power supply of encoder;	2. Check the encoder setup via programme/ motor menu/ encoder steps for the pulse count;
0236	Encoder error of FR motor controller	2. Damaged encoder;	3. Check the encoder feedback speed signals via monitor/motor menu/motor speed A/B;
0336	Encoder error of RL motor controller	3. Improper wiring.	4. If the checks above fail to discover the problem, replace the encoder.

Fault code	Description	Cause	Solution
0436	Encoder error of RR motor controller		Note: The pins #31 and #32 of the 35-pin controller connector are for encoder AB phase output signals.
0037	Open-circuited pump motor controller	<ol style="list-style-type: none"> <li>1. Missing phase in motor;</li> <li>2. Improper wiring;</li> <li>3. Damaged controller.</li> </ol>	<ol style="list-style-type: none"> <li>1. Ensure the 3-phase wiring of UVW free of open circuit;</li> <li>2. Use a multimeter to check the UVW power module works properly;</li> <li>3. If the inspections above fail to discover the problem, replace the motor.</li> </ol>
0137	Open-circuited FL motor controller		
0237	Open-circuited FR motor controller		
0337	Open-circuited RL motor controller		
0437	Open-circuited RR motor controller		
0038	Fused main contactor of pump motor controller	<ol style="list-style-type: none"> <li>1. Fused contact of main contactor;</li> <li>2. Improper wiring.</li> </ol>	<ol style="list-style-type: none"> <li>1. Check the main contactor for fused contact;</li> <li>2. Measure the coil voltage to ensure it is normal;</li> <li>3. Check for correct wiring;</li> <li>4. If the motor has missed phase, check the UV phase for unlinked cable.</li> </ol>
0138	Fused main contactor of FL motor controller		
0238	Fused main contactor of FR motor controller		
0338	Fused main contactor of RL motor controller		
0438	Fused main contactor of RR motor controller		
0039	Main contactor engaging failure of pump motor controller	<ol style="list-style-type: none"> <li>1. Large voltage drop in KSI voltage and battery voltage;</li> <li>2. An element with high power is connected in series in the KSI circuit, which brings the voltage down;</li> <li>3. Contactor damage.</li> </ol>	<ol style="list-style-type: none"> <li>1. Use a handhold to monitor the KSI, ensure the difference between the capacitor voltage (monitor/outputs menu capacitor Voltage) and the key switch voltage is less than the threshold (programme/main contactor/main DNC).</li> <li>2. Check whether an element with high power is connected in the KSI circuit, which brings the voltage down;</li> <li>3. Replace the contactor to find out if it is damaged.</li> </ol>
0139	Main contactor engaging failure of FL motor controller		
0239	Main contactor engaging failure of FR motor controller		
0339	Main contactor engaging failure of RL motor controller		
0439	Main contactor engaging failure of RR motor controller		
0041	High voltage at slider end of accelerator of pump motor controller	<ol style="list-style-type: none"> <li>1. Accelerator wiring disconnected;</li> <li>2. Excessively high output voltage at slider end of accelerator.</li> </ol>	Measure the output voltage at the slider end of accelerator to check if it is too high, replace the accelerator if necessary. Note: The pins #16 of the 35-pin controller connector is for accelerator slider end input.
0141	High voltage at slider end of accelerator of FL motor controller		
0241	High voltage at slider end of accelerator of FR motor controller		

Fault code	Description	Cause	Solution
0341	High voltage at slider end of accelerator of RL motor controller		
0441	High voltage at slider end of accelerator of RR motor controller		
0042	Low voltage at slide end of accelerator of pump motor controller	Excessively low output voltage at slider end of accelerator.	Measure the output voltage at the slider end of accelerator to check if it is too low, replace the accelerator if necessary. Note: The pins #16 of the 35-pin controller connector is for accelerator slider end input.
0142	Low voltage at slider end of accelerator of FL motor controller		
0242	Low voltage at slider end of accelerator of FR motor controller		
0342	Low voltage at slider end of accelerator of RL motor controller		
0442	Low voltage at slider end of accelerator of RR motor controller		
0043	High voltage at slider end of pot2 of pump motor controller		
0143	High voltage at slider end of pot2 of FL motor controller		
0243	High voltage at slider end of pot2 of FR motor controller		
0343	High voltage at slider end of pot2 of RL motor controller		
0443	High voltage at slider end of pot2 of RR motor controller		
0044	Low voltage at slider end of pot2 of pump motor controller	Excessively low output voltage at slider end of pot2.	Measure the voltage at the slider end of pot2, replace it if necessary. Note: The pins #17 of the 35-pin controller connector is for pot2 slider end input.
0144	Low voltage at slider end of pot2 of FL motor controller		
0244	Low voltage at slider end of pot2 of FR motor controller		
0344	Low voltage at slider end of pot2 of RL motor controller		
0444	Low voltage at slider end of pot2 of RR motor controller		

Fault code	Description	Cause	Solution
0045	Pot-low overcurrent of pump motor controller	Excessively low resistance of potentiometer.	Overcurrent at potentiometer low end, replace it if necessary
0145	Pot-low overcurrent of FL motor controller		
0245	Pot-low overcurrent of FR motor controller		
0345	Pot-low overcurrent of RL motor controller		
0445	Pot-low overcurrent of RR motor controller		
0046	Invalid EEPROM of pump motor controller	<ol style="list-style-type: none"> <li>1. Software error;</li> <li>2. Controller failure.</li> </ol>	<ol style="list-style-type: none"> <li>1. Download the correct software version;</li> <li>2. Replace the controller.</li> </ol>
0146	Invalid EEPROM of FL motor controller		
0246	Invalid EEPROM of FR motor controller		
0346	Invalid EEPROM of RL motor controller		
0446	Invalid EEPROM of RR motor controller		
0047	Operation sequence error of pump motor controller	<ol style="list-style-type: none"> <li>1. Input sequence error of key switch, interlock switch, directional switch and accelerator;</li> <li>2. Failure of key switch, interlock switch, directional switch and accelerator;</li> <li>3. Improper wiring.</li> </ol>	<ol style="list-style-type: none"> <li>1. Check the input sequence of switches to exclude the operation-induced cause;</li> <li>2. Use a handhold unit to check each switch condition;</li> <li>3. Use a handhold unit to check the accelerator signal;</li> <li>4. Replace the failed switches.</li> </ol>
0147	Operation sequence error of FL motor controller		
0247	Operation sequence error of FR motor controller		
0347	Operation sequence error of RL motor controller		
0447	Operation sequence error of RR motor controller		
0049	Setup change of pump motor controller	The key switch must be restarted after setup change of some parameters.	Restart the key switch to eliminate the fault.
0149	Setup change of FL motor controller		
0249	Setup change of FR motor controller		
0349	Setup change of RL motor controller		
0449	Setup change of RR motor controller		
0068	VCL run error of pump motor controller	Software problem	<ol style="list-style-type: none"> <li>1. Update the software to the correct version;</li> <li>2. Replace the controller.</li> </ol>
0168	VCL run error of FL motor controller		

Fault code	Description	Cause	Solution
0268	VCL run error of FR motor controller		
0368	VCL run error of RL motor controller		
0468	VCL run error of RR motor controller		
0069	Power supply of pump motor controller exceeding the range	<ol style="list-style-type: none"> <li>1. Excessively high/low current of external loads;</li> <li>2. Check the setup.</li> </ol>	<ol style="list-style-type: none"> <li>1. Check the external loads of 5V and 10V loading devices for short circuit or damage;</li> <li>2. Check the setup (external supply max and external supply min);</li> <li>3. Replace the failed devices.</li> </ol>
0169	Power supply of FL motor controller exceeding the range		
0269	Power supply of FR motor controller exceeding the range		
0369	Power supply of RL motor controller exceeding the range		
0469	Power supply of RR motor controller exceeding the range		
0071	Operation software fault of pump motor controller	<ol style="list-style-type: none"> <li>1. Software problem;</li> <li>2. Controller failure.</li> </ol>	<ol style="list-style-type: none"> <li>1. Update the software to the correct version;</li> <li>2. Replace the controller.</li> </ol>
0171	Operation software fault of FL motor controller		
0271	Operation software fault of FR motor controller		
0371	Operation software fault of RL motor controller		
0471	Operation software fault of RR motor controller		
0072	PDO timeout of pump motor controller	<ol style="list-style-type: none"> <li>1. Software problem;</li> <li>2. CAN bus communication error.</li> </ol>	<ol style="list-style-type: none"> <li>1. Update the software to the correct version, and ensure the bus free of interference;</li> <li>2. Ensure the bus terminal resistance is 60 ohm, the bus voltage approx. 2.5V;</li> <li>3. Ensure the devices on the bus are correctly connected;</li> <li>4. Check the on-bus devices are correctly programmed;</li> <li>5. Use the exclusion method to replace the failed devices.</li> </ol>
0172	PDO timeout of FL motor controller		
0272	PDO timeout of FR motor controller		
0372	PDO timeout of RL motor controller		
0472	PDO timeout of RR motor controller		
0073	Motor stalling of pump motor controller	<ol style="list-style-type: none"> <li>1. Motor stalling;</li> <li>2. Encoder fault;</li> <li>3. Improper wiring or motor damage</li> </ol>	<ol style="list-style-type: none"> <li>1. Check the power supply and wiring of motor encoder to ensure the speed signal can be properly delivered;</li> <li>2. Ensure the brake is fully disengaged;</li> </ol>
0173	Motor stalling of FL motor controller		

Fault code	Description	Cause	Solution
0273	Motor stalling of FR motor controller		3. Check the motor and controller.
0373	Motor stalling of RL motor controller		
0473	Motor stalling of RR motor controller		
0077	System distress of pump motor controller	<ol style="list-style-type: none"> <li>1. The processor discovers illegal and redundant data;</li> <li>2. The processor inside the controller fails;</li> <li>3. The processor discovers the switching value signal exceeds the threshold by 100ms (if the fault occurs repeatedly, please check if the switch gets wet or damaged).</li> </ol>	<ol style="list-style-type: none"> <li>1. Check the internal micro-processor for damage;</li> <li>2. Check input signals of all switches, and ensure the switches free of wetting or damage.</li> </ol>
0177	System distress of FL motor controller		
0277	System distress of FR motor controller		
0377	System distress of RL motor controller		
0477	System distress of RR motor controller		
0078	Incompatible system of pump motor controller	Incompatible operation system	Check the software for compatibility.
0178	Incompatible system of FL motor controller		
0278	Incompatible system of FR motor controller		
0378	Incompatible system of RL motor controller		
0478	Incompatible system of RR motor controller		
0082	Calibration error in pump motor controller	Internal controller fault	Check the internal controller for fault.
0182	Calibration error in FL motor controller		
0282	Calibration error in FR motor controller		
0382	Calibration error in RL motor controller		
0482	Calibration error in RR motor controller		
0083	Power supply fault of pump motor controller	<ol style="list-style-type: none"> <li>1. Internal voltage failure of controller;</li> <li>2. Power supply failure of drive circuit.</li> </ol>	Check the internal controller for fault.
0183	Power supply fault of FL motor controller		
0283	Power supply fault of FR motor controller		

Fault code	Description	Cause	Solution
0383	Power supply fault of RL motor controller		
0483	Power supply fault of RR motor controller		
0087	Motor matching failure of pump motor controller	Description of motor matching failure codes: 0=Normal; 1=Encoder signal received, pseudo not identified, manual setup of the encoder pulse required; 2=Motor temp sensor failure; 3=Motor high-temp response failure; 4=Motor overheat response failure; 5=Motor low-temp response failure; 6=Low-volts response failure; 7=High-volts response failure; 8=Controller fails to detect the encoder signal; 9=Motor setup exceeding the range	Check the encoder and motor for correct wiring.
0187	Motor matching failure of FL motor controller		
0287	Motor matching failure of FR motor controller		
0387	Motor matching failure of RL motor controller		
0487	Motor matching failure of RR motor controller		
0088	Encoder pulse fault of pump motor controller	The encoder parameters do not match the actual motor encoder.	Check the encoder parameters.
0188	Encoder pulse fault of FL motor controller		
0288	Encoder pulse fault of FR motor controller		
0388	Encoder pulse fault of RL motor controller		
0488	Encoder pulse fault of RR motor controller		
0089	Motor type error of pump motor controller	Motor type data setup out of range	Modify the motor type data.
0189	Motor type error of FL motor controller		
0289	Motor type error of FR motor controller		
0389	Motor type error of RL motor controller		
0489	Motor type error of RR motor controller		
0091	VCL/OS mismatch of pump motor controller	Controller program error	Update the program to the correct version.

Fault code	Description	Cause	Solution
0191	VCL/OS mismatch of FL motor controller		
0291	VCL/OS mismatch of FR motor controller		
0391	VCL/OS mismatch of RL motor controller		
0491	VCL/OS mismatch of RR motor controller		
0092	Invalid solenoid brake setup of pump motor controller	<ol style="list-style-type: none"> <li>1. The machine moves freely after solenoid brake is triggered;</li> <li>2. The holding force of solenoid brake is too weak</li> </ol>	<ol style="list-style-type: none"> <li>1. Ensure the correct setup of solenoid brake and accelerator;</li> <li>2. Check the brake disc of solenoid brake to determine whether it needs adjusting.</li> </ol>
0192	Invalid solenoid brake setup of FL motor controller		
0292	Invalid solenoid brake setup of FR motor controller		
0392	Invalid solenoid brake setup of RL motor controller		
0492	Invalid solenoid brake setup of RR motor controller		
0093	Restricted encoder operation of pump motor controller	<ol style="list-style-type: none"> <li>1. Motor stalling or encoder fault causes the restricted operational position of encoder to be activated;</li> <li>2. Improper wiring;</li> <li>3. Machine stalling.</li> </ol>	<ol style="list-style-type: none"> <li>1. Check the encoder power supply and ensure correct wiring;</li> <li>2. Check the encoder setup for pulse count (programme/motor menu/ encoder steps);</li> <li>3. Check the encoder feedback speed signals via monitor/motor menu/motor speed A/B;</li> <li>4. Replace the encoder.</li> </ol>
0193	Restricted encoder operation of FL motor controller		
0293	Restricted encoder operation of FR motor controller		
0393	Restricted encoder operation of RL motor controller		
0493	Restricted encoder operation of RR motor controller		
0094	Emergency reverse response timeout of pump motor controller	<ol style="list-style-type: none"> <li>1. Emergency reverse switch always in closed position;</li> <li>2. EmerTimer expires, which leads to the activation of emergency reverse timeout.</li> </ol>	<ol style="list-style-type: none"> <li>1. Use handhold unit to monitor (monitor /- inputs menu/emerg Rev), if it keeps in the ON position, check the emergency reverse switch;</li> <li>2. Check the wiring of emergency reverse switch;</li> <li>3. Check the programming of emergency reverse.</li> </ol>
0194	Emergency reverse response timeout of FL motor controller		
0294	Emergency reverse response timeout of FR motor controller		

Fault code	Description	Cause	Solution
0394	Emergency reverse response timeout of RL motor controller	<ol style="list-style-type: none"> <li>1. Controller model unidentifiable;</li> <li>2. Controller software error;</li> <li>3. Controller damage.</li> </ol>	<ol style="list-style-type: none"> <li>1. Check the controller model;</li> <li>2. Check the software version;</li> <li>3. Replace the controller.</li> </ol>
0494	Emergency reverse response timeout of RR motor controller		
0098	Model error of pump motor controller		
0198	Model error of FL motor controller		
0298	Model error of FR motor controller		
0398	Model error of RL motor controller		
0498	Model error of RR motor controller	<p>When the dual-motor is on, the control mode is not set as 0 or 1.</p>	<p>When the dual-motor is on, the control mode shall be set as 0 or 1. Check the parameter setting.</p>
0099	2WD machine motor setup mismatch of pump motor controller		
0199	2WD machine motor setup mismatch of FL motor controller		
0299	2WD machine motor setup mismatch of FR motor controller		
0399	2WD machine motor setup mismatch of RL motor controller		
0499	2WD machine motor setup mismatch of RR motor controller		

**Table 6-18 Special fault code description for electric motor controller**

Fault Code	Description	Cause	Check
0052	CAN communication timeout of pump motor controller	Communication timeout 1s between motor controller and machine main controller	Check CAN3 signal lines between pump motor controller and machine main controller.
0053	Charging voltage overload of pump motor controller	Pump motor controller voltage 59V and timeout 3s	Check CAN3 signal lines between pump motor controller and machine main controller.
0152	CAN communication timeout of FL motor controller	Communication timeout 1s between FL motor controller and machine main controller.	Check CAN3 signal lines between FL motor controller and machine main controller.

<b>Fault Code</b>	<b>Description</b>	<b>Cause</b>	<b>Check</b>
0153	Communication timeout between FL and FR motor controllers	Communication timeout 1s between FL and FR motor controllers	Check CAN3 signal lines between FL and FR motor controllers.
0154	Communication timeout between FL and RL motor controllers	Communication timeout 1s between FL and RL motor controllers	Check CAN3 signal lines between FL and RL motor controllers.
0155	Communication timeout between FL and RR motor controllers	Communication timeout 1s between FL and RR motor controllers	Check CAN3 signal lines between FL and RR motor controllers.
0252	CAN communication timeout of FR motor controller	Communication timeout 1s between FR motor controller and machine main controller.	Check CAN3 signal lines between FR motor controller and machine main controller.
0257	Communication timeout between FR motor and main control (FL)	FR motor controller timeout 1s to receive signal from FL motor controller	Check CAN3 signal lines between FR and FL motor controllers.
0352	CAN communication timeout of RL motor controller	Communication timeout 1s between RL motor controller and machine main controller.	Check CAN3 signal lines between RL motor controller and machine main controller.
0356	Communication timeout between RL motor and main control (FL)	RL motor controller timeout 1s to receive signal from FL motor controller	Check CAN3 signal lines between RL and FL motor controllers.
0452	CAN communication timeout of RR motor controller	Communication timeout 1s between RR motor controller and machine main controller.	Check CAN3 signal lines between RR motor controller and machine main controller.
0458	Communication timeout between RR motor and main control (FL)	RR motor controller timeout 1s to receive signal from FL motor controller	Check CAN3 signal lines between RR and FL motor controllers.

**Table 6-19 Lithium battery BMS fault code description**

<b>Fault Code</b>	<b>Description</b>	<b>Fault Code</b>	<b>Description</b>
0x101	Total Voltage Overvoltage-First Level	0x208	Discharge at High Temperature-Second Level
0x201	Total Voltage Overvoltage-Second Level	0x308	Discharge at High Temperature-Third Level
0x301	Total Voltage Overvoltage-Third Level	0x109	Charging at High Temperature-First Level
0x102	Total Voltage Undervoltage-First Level	0x209	Charging at High Temperature-Second Level
0x202	Total Voltage Undervoltage-Second Level	0x309	Charging at High Temperature-Third Level

Fault Code	Description	Fault Code	Description
0x302	Total Voltage Undervoltage-Third Level	0x10A	Large Temperature Difference-First Level
0x103	Battery Cell Overvoltage Threshold-First Level	0x20A	Large Temperature Difference-Second Level
0x203	Battery Cell Overvoltage Threshold-Second Level	0x30A	Large Temperature Difference-Third Level
0x303	Battery Cell Overvoltage Threshold-Third Level	0x10B	Charging Overcurrent Threshold-First Level
0x104	Battery Cell Undervoltage Threshold-First Level	0x20B	Charging Overcurrent Threshold-Second Level
0x204	Battery Cell Undervoltage Threshold-Second Level	0x30B	Charging Overcurrent Threshold-Third Level
0x304	Battery Cell Undervoltage Threshold-Third Level	0x10C	Discharge Overcurrent Threshold-First Level
0x105	Battery Cell Voltage Difference-First Level	0x20C	Discharge Overcurrent Threshold-Second Level
0x205	Battery Cell Voltage Difference-Second Level	0x30C	Discharge Overcurrent Threshold-Third Level
0x305	Battery Cell Voltage Difference-Third Level	0x10D	Low SOC-First Level
0x106	Discharge of Low Temperature-First Level	0x20D	Low SOC-Second Level
0x206	Discharge of Low Temperature-Second Level	0x30D	Low SOC-Third Level
0x306	Discharge of Low Temperature-Third Level	0x10E	High SOC-First Level
0x107	Charging at Low Temperature-First Level	0x20E	High SOC-Second Level
0x207	Charging at Low Temperature-Second Level	0x30E	High SOC-Third Level
0x307	Charging at Low Temperature-Third Level	0x20F	BMS Communication Fault-Second Level
0x108	Discharge at High Temperature-First Level	0x210	Abnormal Communication with Charger-Second Level



**Notes:** In case of any fault alarm, please contact Sinoboom after-sales personnel.

## Use and Maintenance of Battery

The battery falls into 3 types: lead acid, lead acid maintenance-free and lithium batteries. The lithium battery and lead acid maintenance-free battery are free of maintenance.

**⚠ WARNING**



**FIRE AND EXPLOSION HAZARD**

- Batteries contain sulfuric acid and generate explosive mixtures of hydrogen and oxygen gases. Keep any device that may produce sparks or flames (- including cigarettes/smoking materials) away from the battery to prevent explosion.
- Do not touch the battery terminals or cable clips with tools that may produce sparks.

**⚠ WARNING**


**ELECTROCUTION HAZARD**

- Contact with hot circuits may cause serious injury or death. Be sure to wear goggles, gloves and protective clothing.
- Remove all rings, watches and other accessories.

**⚠ WARNING**



**CHEMICAL BURN HAZARD**



- Avoid spilling battery acid on unprotected skin or unprotected skin in contact with battery acid. Seek medical attention immediately if the skin comes in contact with battery acid .
- If the battery acid escapes, please use baking soda to neutralize the acid.

**⚠ WARNING**

**UNSAFE OPERATION HAZARD**

- Strictly follow the manufacturer's recommendations on how to properly use and maintain the battery.
- Cut off the battery main switch if the battery is not to be used for an extended period.
- The waste battery may pose danger, so do not discard batteries at will. If it needs to be scrapped, contact a battery recycling company.
- Except for the professionals, do not perform a systematic maintenance or service to the battery, otherwise it may cause bodily injuries or damage to the battery system.
- Except for the professionals, do not tamper with the settings or service a signal light, otherwise it may cause bodily injuries or damage to the battery system.
- Except for the professionals, do not remove the battery housing, otherwise it may cause damage to the battery system.

**NOTICE**

*It will not be covered by the warranty if the battery attenuates or fails due to customer's overuse (- continued use after battery level less than 10%) or battery out of charge for a long time (not timely charged for 3 days or longer when the battery level less than 10%).*

**Inspection**

See the *Inspect the Battery* section in this manual.

**Cleaning**

- Clean the top, terminals and connections of the battery with a cloth or brush and mixed solution of sodium bicarbonate and water. Do not let the cleaning solution enter the battery.
- Clean the top, terminals and connections with water and wipe them dry with a cloth. Apply a thin layer of petroleum jelly to the terminals or use terminal protector.
- Keep the area around the battery clean and dry.

**Charging**

See the **Charging the Battery** section of Operation Manual.

## Equalizing

Equalization is the deliberate process of overcharging the flooded/wet battery after it has been fully charged. Equalize the battery only when the specific gravity of battery is low (less than 1.25) or the scope (0.030) of the specific gravity is wide after the battery is fully charged.

Note :

- Verify whether the battery is flooded/wet battery.
  - To prevent battery damage, the battery must be equalized within a maximum of 3 months storage after delivery.
1. Inspect the electrolyte level height to ensure a proper electrolyte level.
  2. Verify all vent caps are properly secured to the battery.
  3. Set the charger to equalization mode.
  4. Charge the battery in equalization mode.

The battery will bleed air in the equalization process (forming bubbles).

5. Remove the vent cap every hour to measure the gravity of all battery cells, if the gravity doesn't increase, stop the charging in equalization mode.

## Storage

- Fully charge the battery before storage.
- The battery should be stored in cool and dry environment (temperature 10°C~25°C, RH less than 90%), and charge the battery every 3 months using the charger provided by the manufacturer.
- Disconnect the power-off plug to prevent potential parasitic loading, which may cause electrical leakage of the battery.
- The battery will self-discharge gradually during storage. Monitor the specific gravity or the voltage every 4 ~ 6 weeks. The comparison of the charging state with specific gravity and open-circuit voltage is shown in the following table.

**Table 6-20**

Percentage Charging (%)	Specific Gravity	Open-Circuit Voltage (V)		
		Battery Cell	6V	12V
100	1.277	2.122	6.37	12.73
90	1.258	2.103	6.31	12.62
80	1.238	2.083	6.25	12.50
70	1.217	2.062	6.19	12.37
60	1.195	2.040	6.12	12.24
50	1.172	2.017	6.05	12.10
40	1.148	1.993	5.98	11.96
30	1.124	1.969	5.91	11.81
20	1.098	1.943	5.83	11.66
10	1.073	1.918	5.75	11.51

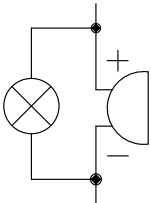
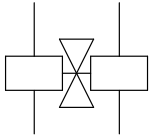
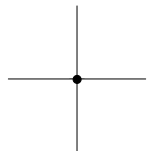
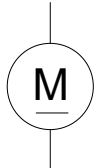
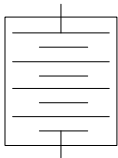
- Recharge the battery in quick mode when the battery level is 70% or lower.
- Recharge the battery before use after removing it from storage.
- Storage in hot environments (above 32°C [90°F]): During storage, do not expose the battery directly to the heat source. The self-discharge process will accelerate in warmer temperatures. If storing the battery in hot temperatures or during hot weather, monitor the specific gravity or the voltage more frequently (about every 2 - 4 weeks).
- Storage in cold environments (below 0°C [32°F]): During storage, do not store the battery in a place with an estimated temperature reaching the freezing point; if the battery has not been fully charged, it may freeze in cold temperatures. If storing the battery in cold temperatures or during cold weather, **fully charge** the battery. This point is very important.

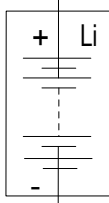
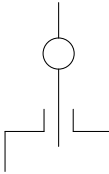
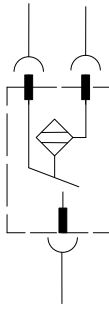
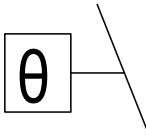
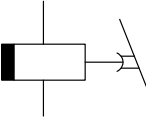
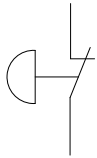
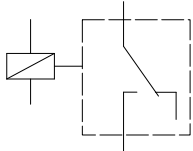
**NOTICE**

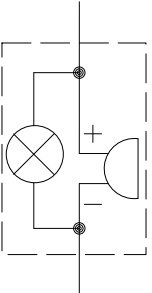
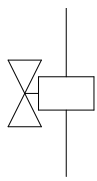
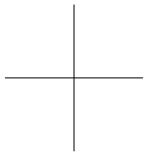
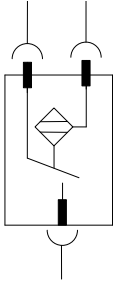
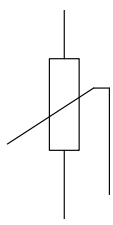
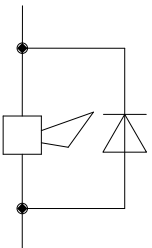
- Do not store more than 6 months in hot or cold environment.
- It will not be covered by the warranty if the battery attenuates or fails due to customer's overuse (- continued use after battery level less than 10%) or battery out of charge for a long time (not timely charged for 3 days or longer when the battery level less than 10%).

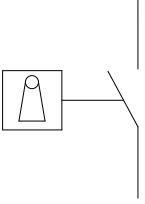
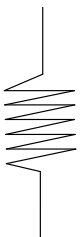
Electrical Symbols

Table 6-21

Symbol	Description
	Buzzer
	Valve
	Two lines connected
	Motor
	Storage battery

Symbol	Description
	Lithium battery
	Toggle switch
	Level switch
	Oil temperature switch
	Delay relay
	Power-off switch
	Relay

Symbol	Description
	Warning lamp
	Valve
	Two lines non-connected
	Proximity switch/ Pressure sensor
	Fuel level sensor
	Horn

Symbol	Description
	Key switch
	Preheating wire

Electrical Schematic

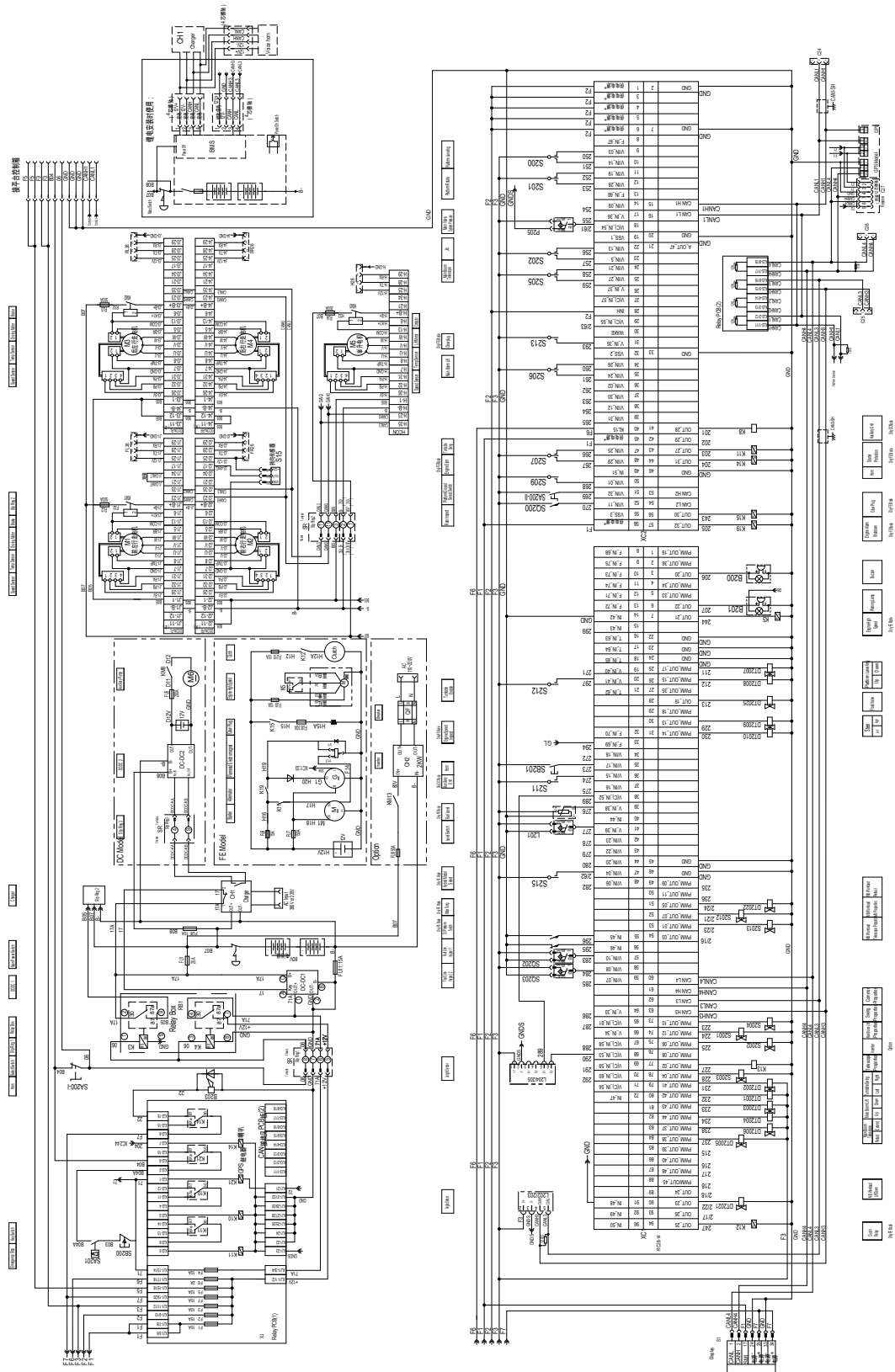


Figure 6-34 Electrical schematic of turntable

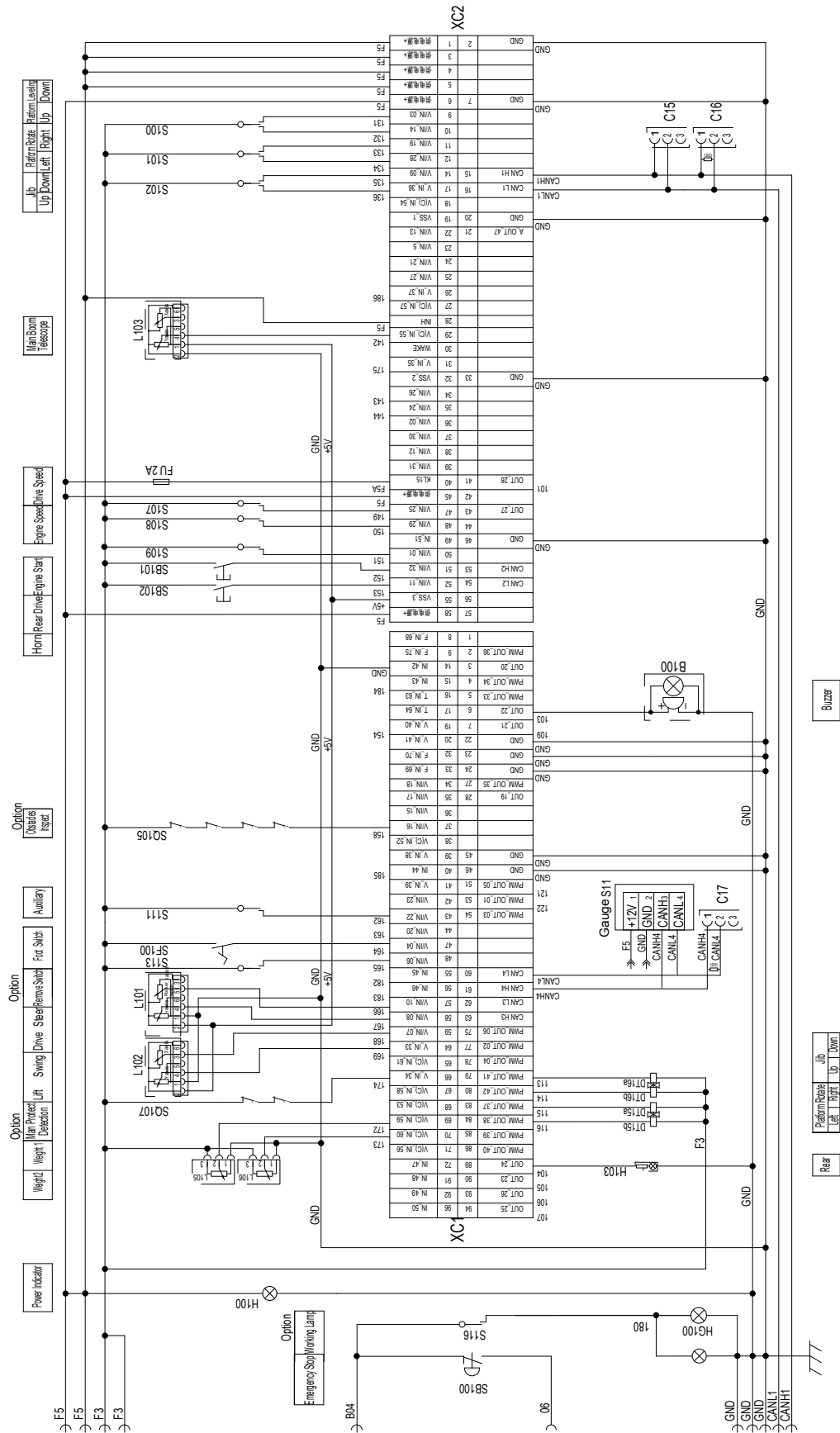


Figure 6-35 Electrical schematic of platform

# 7 CONTROL SYSTEM

## DANGER

All operations in this section must be performed by qualified personnel who have been professionally trained and authorized by Sinoboom, otherwise the consequences will be at your own risk.

## WARNING

### UNSAFE OPERATION HAZARD



- **The machine has been commissioned before delivery. It's forbidden to modify the system settings and update the program without authorization from Sinoboom.**

**Due to different machine configurations, certain descriptions below may be inapplicable to your machine. In case of any operational questions when operating the machine as per the manual, please stop operation and contact Sinoboom after-sales personnel in time.**

- **Incorrect operation may result in death, serious injury or machine damage.**

## NOTICE

*PCU, ECU, sensors, etc. are precisely adjusted and protected before delivery. Therefore, personnel who have not been professionally trained and authorized by Sinoboom cannot disassemble their housings, otherwise moisture and dust will enter the internal mechanism and normal operation will not be guaranteed.*

This section is applicable to Rexroth system equipped with Rising display.

## DISPLAY INTERFACE

The system interface is described in the figure below:

Note: some interfaces can only be accessed with a password (the password can only be provided to personnel professionally trained and authorized by Sinoboom).

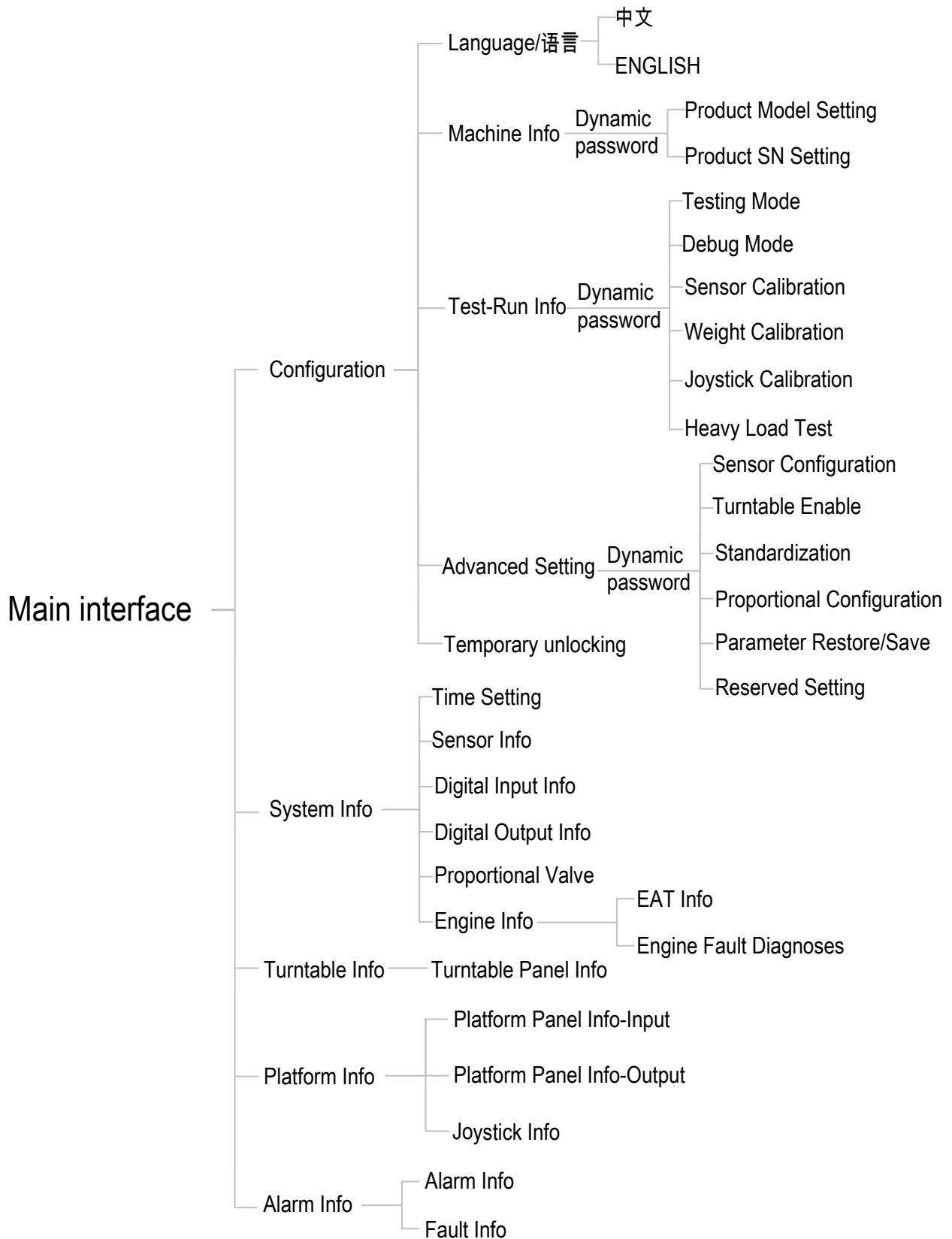


Figure 7-1 Display interface navigation diagram

## MAIN INTERFACE AFTER BOOTING

emergency stop button to the ON position, and turn the key switch to the ON position, and the system will be powered on.

Turn the ground/platform select switch on the ground controller to the ground control position, pull out the

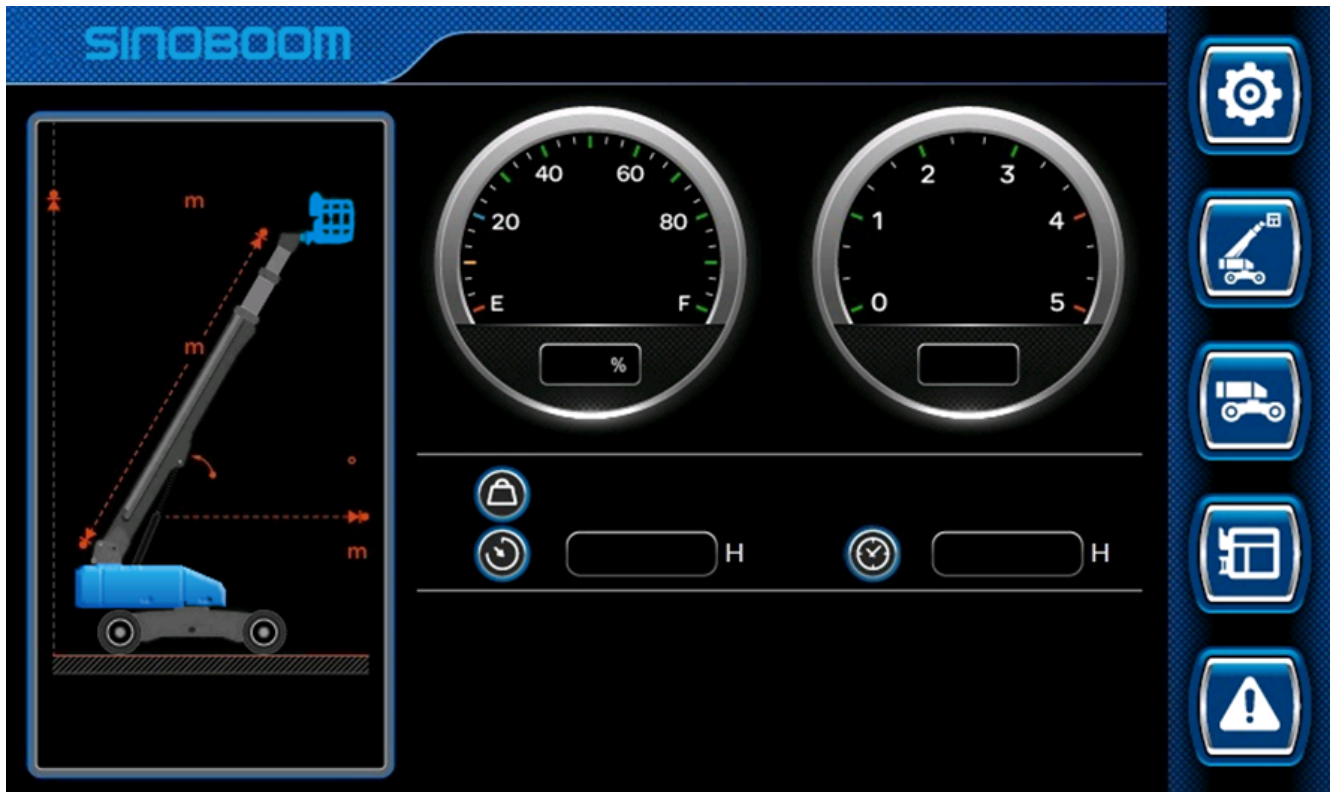





















Figure 7-2 Main interface after booting

## DESCRIPTION OF ICON FUNCTION



Table 7-1

Icon	Description	Icon	Description
	Configuration		Left/Right arrow key
	Turntable information		Increase key

	System information		Decrease key
	Platform information		Return key
	Alarm information		Enter key
	Up arrow key		Previous page
	Down arrow key		Enter/next page
	Right arrow key		Press and hold for 3s to save the current page parameters and jump to the next page /Press to directly jump to the next page
	Left arrow key		Press and hold for 3s to save the current page parameters and return to the previous menu /Press to directly return to the previous menu
	Up/Down arrow key		

## LANGUAGE SETTING

Figure 7-3 CONFIGURATION interface

1. Press  on the main interface to enter CONFIGURATION interface.
2. Select Language through  and , and press  to enter LANGUAGE interface.

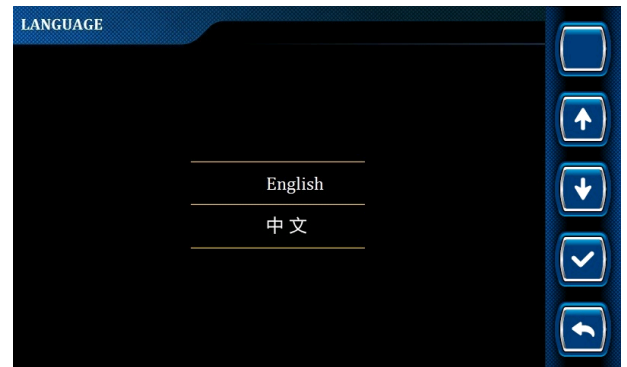
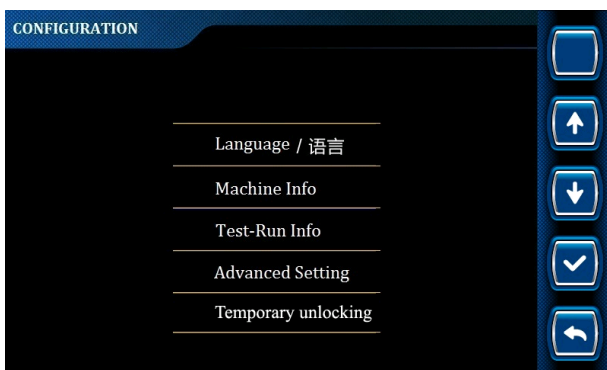










Figure 7-4 LANGUAGE interface

3. Select 中文 or English through  and , and press and hold  for 3s to complete language setting.
4. Press  successively to return to the main interface, and power off the machine as required.

## TEST-RUN INFORMATION

1. Press  on the main interface to enter CONFIGURATION interface.
2. According to the navigation diagram of display interface, enter TEST-RUN INFO interface by pressing ,  and  successively.

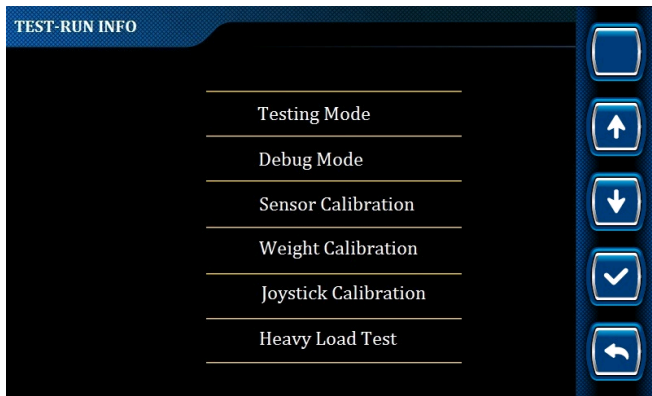





Figure 7-5 TEST-RUN INFO interface

### Sensor calibration

- This operation is used to calibrate sensors other than the weighing sensor (its calibration method will be described in detail in the subsequent **weight calibration**).
  - If the machine is equipped with a dual-channel sensor, only 1 channel is needed to be selected for maximum and minimum value calibration.
1. On the TEST-RUN INFO interface, select Sensor Calibration through  and , and enter SENSOR CALIBRATION interface by pressing .

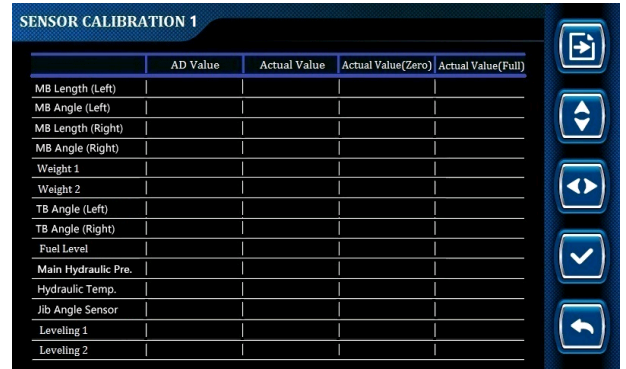


Figure 7-6 SENSOR CALIBRATION 1 interface

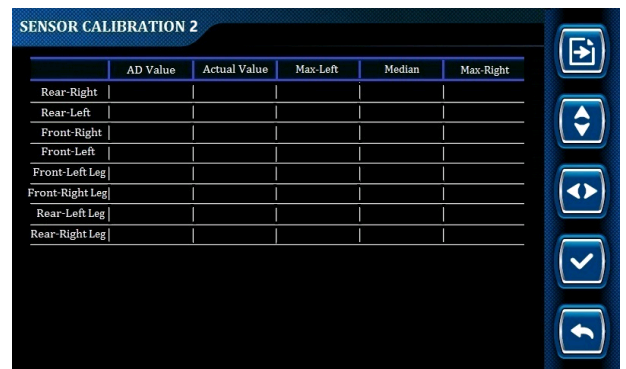


Figure 7-7 SENSOR CALIBRATION 2 interface

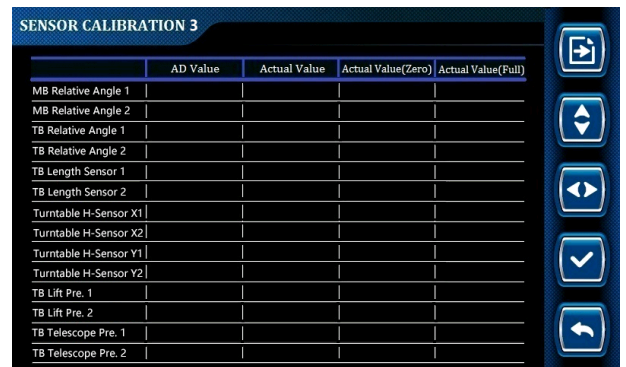








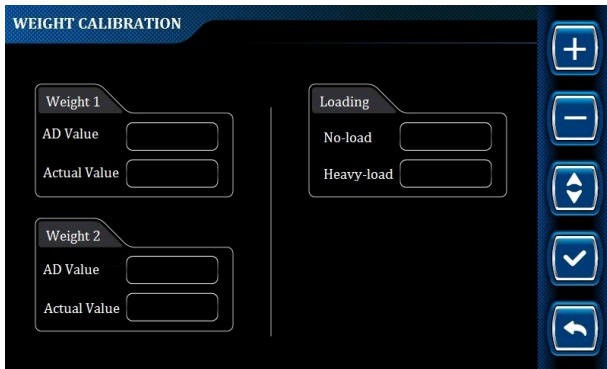
Figure 7-8 SENSOR CALIBRATION 3 interface

2. On the SENSOR CALIBRATION interface, select the position to be calibrated through  and  (- there will be the flashing  before the selected option), press and hold  for 3s to complete the calibration (the icon before the selected option is switched from  to , indicating calibration succeeded, and the corresponding actual value will be changed).

3. If re-calibrating the parameters at this position is required, press to return to the TEST-RUN INFO interface, then re-enter the SENSOR CALIBRATION interface, and repeat the previous step.
4. Press successively to return to the main interface, and power off the machine as required.

## Weight calibration

1. Make sure that no heavy objects are placed on the platform and that the platform is stable without shaking.
2. Enter the TEST-RUN INFO interface.
3. On the TEST-RUN INFO interface, select Weight Calibration through and , and press to enter the WEIGHT CALIBRATION interface.



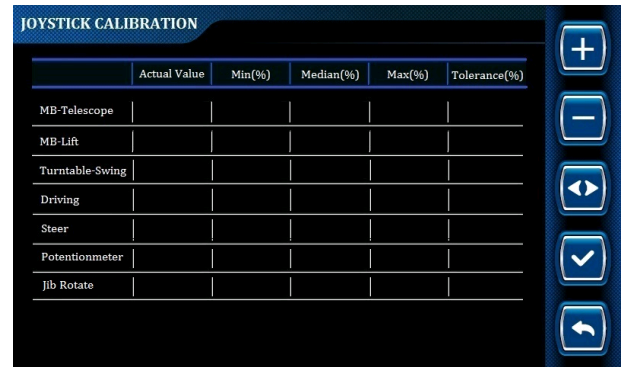
**Figure 7-9 WEIGHT CALIBRATION interface**

4. On the WEIGHT CALIBRATION interface, select No-load in the Loading column on the right side of the display screen through , adjust the value to 0 through and , and press and hold for 3s to complete the no-load calibration.
5. Place a heavy object with the weight equal to the rated load of the machine on the platform, and ensure that the platform is stable without shaking.
6. Select Heavy-load in the Loading column on the right side of the display screen through , adjust the value to the weight value of the heavy object on the platform through and , and press and hold for 3s to complete the heavy-load calibration (the actual weight value on the left side of the corresponding display screen is equal to the weight value of loads on the platform).
7. If re-calibration is required, press to return to the TEST-RUN INFO interface, then re-enter the WEIGHT CALIBRATION interface, and repeat the previous step.

8. Press successively to return to the main interface, and power off the machine as required.
  - If the machine is equipped with a dual-channel sensor, when pressing and holding for no-load and heavy-load calibration, the weight of two channels will be calibrated at the same time.

## Joystick calibration

1. On the TEST-RUN INFO interface, select Joystick Calibration through and , and press to enter the JOYSTICK CALIBRATION interface.







**Figure 7-10 JOYSTICK CALIBRATION interface**

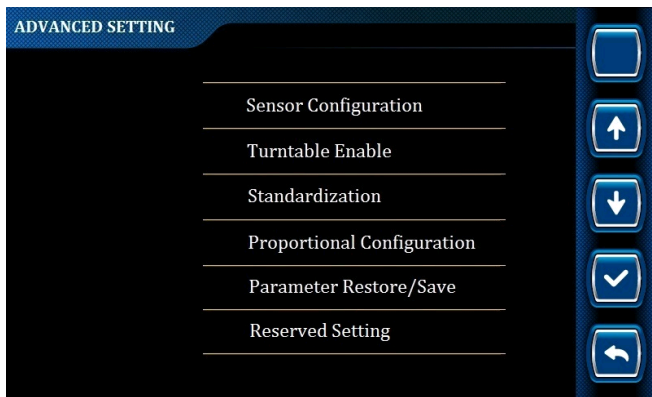
2. On the JOYSTICK CALIBRATION interface, select the joystick option to be calibrated through , change the tolerance through and , and press to save the value and complete the calibration (the icon before the selected option will be changed from to , indicating calibration succeeded; there will be the icon on the interface when tolerance value is saved.)
3. If re-calibration is required, press to return to the TEST-RUN INFO interface, then re-enter the JOYSTICK CALIBRATION interface, and repeat the previous step.
4. Press successively to return to the main interface, and power off the machine as required.

## ADVANCED SETTING

**⚠ DANGER**




Personnel who have not been professionally trained and authorized by Sinoboom are not allowed to modify the advanced setting (including sensor configuration, turntable enable, standardization, proportional configuration, parameter restore/save and reserved setting); otherwise they will be responsible for the consequences.

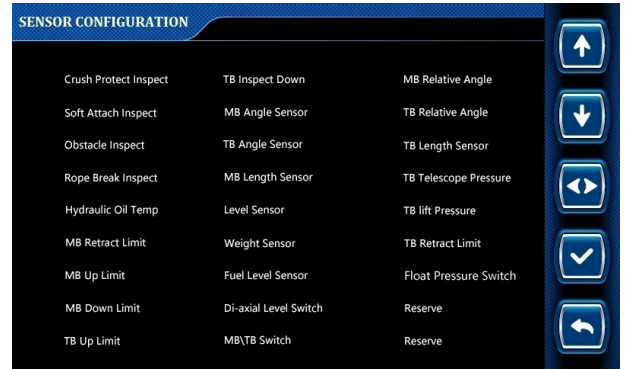
1. Press  on the main interface to enter CONFIGURATION interface.
2. According to the navigation diagram of display interface, enter Advanced Setting interface (- password required) by pressing ,  and  successively.








**Figure 7-11 ADVANCED SETTING interface**

### Sensor configuration




- The sensor configuration function is mainly used to turn on/off switches or sensors on the machine.
  - The configuration of sensors is subject to the actual machine configuration.
1. On the ADVANCED SETTING interface, select Sensor Configuration through  and , and press  to enter SENSOR CONFIGURATION interface.

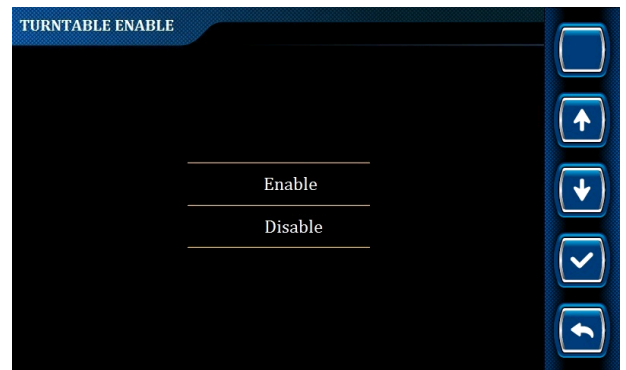


**Figure 7-12 SENSOR CONFIGURATION interface**







2. On the SENSOR CONFIGURATION interface, select the desired item through ,  and , and press  to turn on/off the selected item.
3. Press  successively to return to the main interface, and power off the machine as required.

### Turntable enable

1. On the ADVANCED SETTING interface, select Turntable Enable through  and , and press  to enter TURNTABLE ENABLE interface.

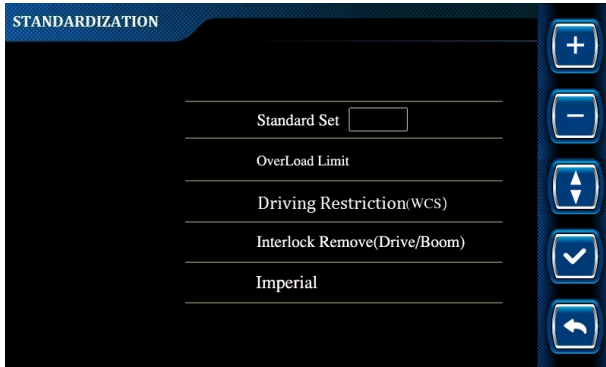


**Figure 7-13 TURNTABLE ENABLE interface**






2. On the TURNTABLE ENABLE interface, select Enable or Disable through  and , and press and hold  for 3s to confirm the setting (there will be the icon  before the selected option after successful setting).
3. To re-select the option, press  to return to the ADVANCED SETTING interface, re-enter the TURNTABLE ENABLE interface, and repeat the above steps.
4. Press  successively to return to the main interface, and power off the machine as required.






## Standardization




1. On the ADVANCED SETTING interface, select Standardization through  and , and press  to enter STANDARDIZATION interface.

















**Figure 7-14 STANDARDIZATION interface**

2. **Standard setting:** On the STANDARDIZATION interface, select Standard Set option through , change the value through  and , and press and hold  for 3s to confirm the setting (there will be the icon  before the selected option after successful setting).

- After changing the value to “0” and confirming the setting, the program will not implement any standard restrictions.
- After changing the value to “1” and confirming the setting, the program will implement the restrictions of CE standard, and the icon of CE standard (  ) will be displayed in the upper right corner of the main interface.
- After changing the value to “2” and confirming the setting, the program will implement the restrictions of ANSI standard, and the icon of ANSI standard (  ) will be displayed in the upper right corner of the main interface.
- After changing the value to “3” and confirming the setting, the program will implement the restrictions of CSA standard, and the icon of CSA standard (  ) will be displayed in the upper right corner of the main interface.
- After changing the value to “4” and confirming the setting, the program will implement the restrictions of AS standard, and the icon of AS standard (  ) will be displayed in the upper right corner of the main interface.
- After changing the value to “5” and confirming the setting, the program will implement the restrictions of KCS standard, and the icon of KCS standard (  ) will be displayed in the upper right corner of the main interface.

- After changing the value to “6” and confirming the setting, the program will implement the restrictions of JIS standard, and the icon of JIS standard (  ) will be displayed in the upper right corner of the main interface.
- After changing the value to “7” and confirming the setting, the program will implement the restrictions of EAC standard, and the icon of EAC standard (  ) will be displayed in the upper right corner of the main interface.
- After changing the value to “8” and confirming the setting, the program will implement the restrictions of UKC standard, and the icon of UKC standard (  ) will be displayed in the upper right corner of the main interface.

3. **Overload limit setting:** On the STANDARDIZATION interface, select Overload Limit option through , and press and hold  for 3s to confirm the setting. There will be the icon  before the selected option after successful setting, and the KG icon (  ) will be displayed in the upper right corner of the main interface.
  4. **Driving restriction (WCS) setting:** On the STANDARDIZATION interface, select Driving Restriction (WCS) option through , and press and hold  for 3s to confirm the setting. There will be the icon  before the selected option after successful setting, and the DR icon (  ) will be displayed in the upper right corner of the main interface.
  5. **Interlock remove (drive/boom) setting:** On the STANDARDIZATION interface, select Interlock Remove (Drive/Boom) option through , and press and hold  for 3s to confirm the setting. There will be the icon  before the selected option after successful setting, and the D/B icon (  ) will be displayed in the upper right corner of the main interface.
  6. To re-select the test option, press  to return to the ADVANCED SETTING interface, re-enter the STANDARDIZATION interface, and repeat the above steps to select the desired option.
  7. Press  successively to return to the main interface, and power off the machine as required.
- In KG mode, when the platform is overloaded, a series of actions of the machine in operating position will be restricted. The difference between KG mode and non-KG mode can be found in the **Inspect Weighing System** section in the maintenance procedures of this Manual.
  - In DR mode, the driving function of the machine in operating position will be restricted.
  - In D/B mode, driving function and boom actions can be performed at the same time.

Proportional configuration

1. On the ADVANCED SETTING interface, select Proportional Configuration through and , and press to enter PROPOR. CONFIG 1 interface.

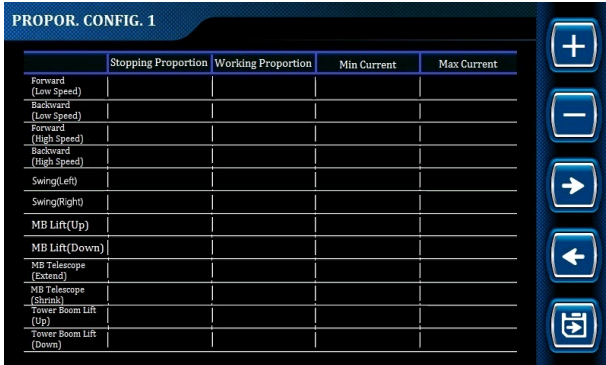


Figure 7-15 PROPOR. CONFIG 1 interface

2. On the PROPOR. CONFIG 1 interface, select the parameter to be adjusted through and (the selected option will be flashing), change the selected parameter value through and , press and hold for 3s to save the parameters on the current page and jump to PROPOR. CONFIG 2 interface (there will be the icon in the top middle of the interface after successful saving), or press to jump to PROPOR. CONFIG 2 interface without saving the parameters on the current page.



Figure 7-16 PROPOR. CONFIG 2 interface

3. Similarly, on the PROPOR. CONFIG 2 interface, follow the above operations to change the parameters requiring adjustment, and jump to the PROPOR. CONFIG 3 interface.

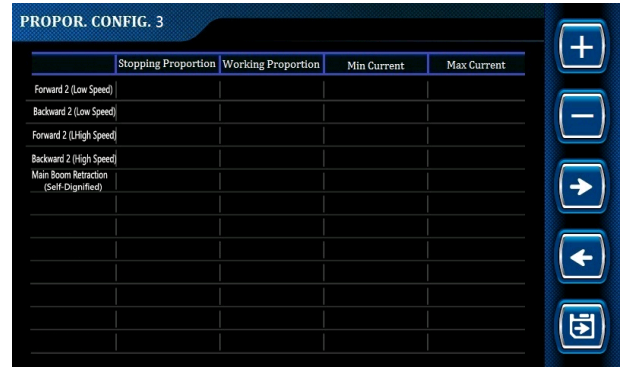


Figure 7-17 PROPOR. CONFIG 3 interface

4. Similarly, on the PROPOR. CONFIG 3 interface, follow the above operations to change the parameters requiring adjustment, and jump to the PROPOR. CONFIG 4 interface.

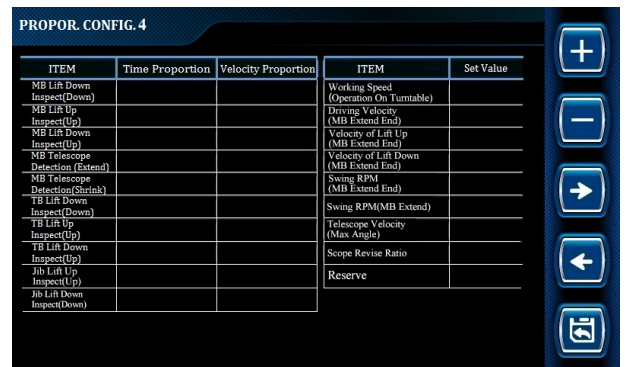


Figure 7-18 PROPOR. CONFIG 4 interface

5. On the PROPOR. CONFIG 4 interface, follow the above operations to change the parameters requiring adjustment. Press and hold for 3s to save the parameters on the current page and return to the previous ADVANCED SETTING interface, or press to return to the previous ADVANCED SETTING interface without saving the parameters on the current page.
6. Press successively to return to the main interface, and power off the machine as required.

Notes:

The maximum current, minimum current, working proportion, and stopping proportion are only valid for actions controlled by proportional valves. For actions not controlled by proportional valves, please adjust the working proportion and stopping proportion to within 10, otherwise the action response will be delayed.

- Minimum current: refers to the starting current of actions, which affects the starting and inching performance of actions. The minimum current should be set to a value that allow the action to just

get started, and it can be identified through the debug mode.




- Maximum current: refers to the maximum current of actions. If it is too low, the speed of actions will be affected, and if it is too high (exceeding the full-open current of the proportional valve), the buffering performance of actions will be affected.
- Working proportion: refers to the starting buffer slope of actions. The smaller the proportion value, the bigger the starting buffer slope and the shorter the time required; the larger the proportion value, the smaller the starting buffer slope and the longer the required time. This parameter can be used to improve the starting hysteresis and starting impact performance of actions.
- Stopping proportion: refers to the stopping buffer slope of actions. The smaller the proportion value, the bigger the stopping buffer slope and the shorter the time required; the larger the proportion value, the smaller the stopping buffer slope and the longer the time required. This parameter can be used to improve the stopping hysteresis and stopping impact performance of actions.
- Time proportion: omitted.
- Speed proportion: used to adjust the target current of action buffering. The smaller the proportion value, the lower the target current and the slower the action; the larger the proportion value, the higher the target current and the faster the action. This parameter can be used to adjust the action speed in the buffer zone.

**Table 7-2 Description of items on PROPOR. CONFIG 4 interface**

No.	Item	Description	Applicable machines
1	MB Lift Down Inspect (Down)	To set the time and speed proportion of main boom when fully lowered during luffing-down. Condition of fully lowering: down limit switch is triggered or the main boom is positioned at an angle smaller than the set value.	TB, AB
2	MB Lift Up Inspect (Up)	To set the time and speed proportion of main boom when fully raised during luffing-up. Condition of fully raising: up limit switch is triggered or the main boom is positioned at an angle bigger than the set value.	TB, AB
3	MB Lift Down Inspect (Up)	To set the time and speed proportion of main boom when fully raised during luffing-down. Condition of fully raising: up limit switch is triggered or the main boom is positioned at an angle bigger than the set value.	TB, AB
4	MB Telescope Detection (Extend)	To set the time and speed proportion of main boom when fully extended. Condition of fully extending: the extended length is bigger than the set value.	TB
5	MB Telescope Detection (Shrink)	To set the time and speed proportion of main boom when fully retracted. Condition of fully retracting: the retracting limit switch is triggered or the extended length is smaller than the set value.	TB, AB
6	TB Lift Down Inspect (Down)	To set the time and speed proportion of articulated boom when fully lowered during luffing-down. Condition of fully lowering: down limit switch is triggered or the articulated boom is positioned at an angle smaller than the set value.	AB
7	TB Lift Up Inspect (Up)	To set the time and speed proportion of articulated boom when fully raised during luffing-up. Condition of fully raising: up limit switch is triggered or the articulated boom is positioned at an angle bigger than the set value.	AB

8	TB Lift Down Inspect (Up)	To set the time and speed proportion of main boom when fully raised during luffing-down. Condition of fully raising: up limit switch is triggered or the articulated boom is positioned at an angle bigger than the set value.	AB
9	Jib Lift Up Inspect (Up)	To set the time and speed proportion of jib boom when fully raised during luffing-up. Condition of fully raising: up limit switch is triggered or the jib boom is positioned at an angle bigger than the set value.	TB, AB
10	Jib Lift Down Inspect (Up)	To set the time and speed proportion of jib boom when fully lowered during luffing-down. Condition of fully lowering: down limit switch is triggered or the jib boom is positioned at an angle smaller than the set value.	TB, AB
11	Working Speed (- Operation on Turntable)	To set the speed of turntable rotation.	TB, AB
12	Driving Velocity (MB Extend End)	To set the travel speed with the main boom fully extended.	TB
13	Velocity of Lift Up (MB Extend End)	To set the luffing-up speed with the main boom fully extended (max angle).	TB
14	Velocity of Lift Down (MB Extend End)	To set the luffing-down speed with the main boom fully extended (max angle).	TB
15	Swing RPM (MB Extend End)	To set the rotation speed with the main boom fully extended (max angle).	TB
16	Swing RPM (MB Extend)	To set the rotation speed with the main boom extended. Condition: the retracting limit switch disengages or the main boom is longer than 1.2m.	AB
17	Telescope Velocity (Max angle)	To set the extending/retracting speed with the main boom at the max angle.	TB
18	Scope Revise Ratio	To slightly adjust the operating range of telescopic boom (not used yet).	TB
<b>Notes: All parameters can be adjusted within 0~100.</b>			

Parameter restore/save

1. On the ADVANCED SETTING interface, select Parameter Restore/Save through  and , and press  to enter PARAMETER RESTORE/SAVE interface.

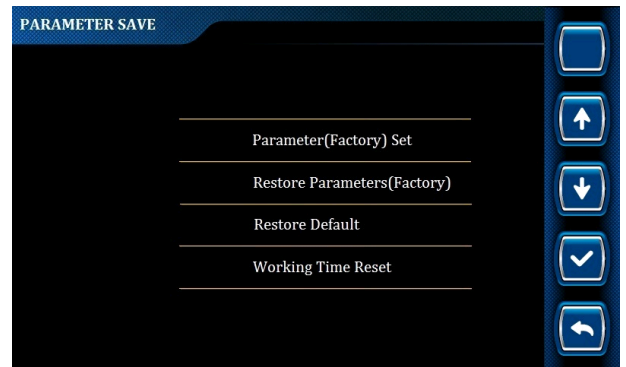


Figure 7-19 PARAMETER RESTORE/SAVE interface

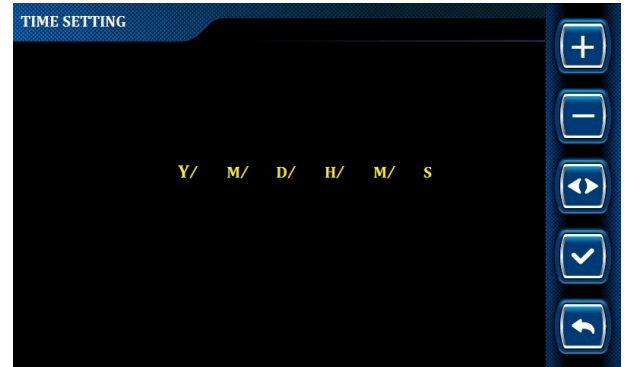
- On the PARAMETER SAVE interface, select the desired function through and , (there will be the icon before the selected option), press and hold for 3s to confirm the selection (there will be the icon before the selected option after confirmation).
- Press successively to return to the main interface, and power off the machine as required.

**Notes:**

- Parameter (factory) set: used to save the current parameters as factory parameters and the original factory parameters will be overwritten. Please use this function with caution.
- Restore parameters (factory): used to restore the current parameters to the factory parameters and the current parameters will be overwritten. Please use this function with caution.
- Restore default: used to restore the current parameters to the default parameters and the current parameters will be restored. This function shall be used with caution and generally only used in the initial installation and debugging (requiring a password to restore the default parameters).
- Working time reset: used to clear the total working time (after clearing, the total working time is about 36.5h). Please use this function with caution.

## Time setting

- On the SYSTEM INFO interface, select Time Setting through and , and press to enter TIME SETTING interface.

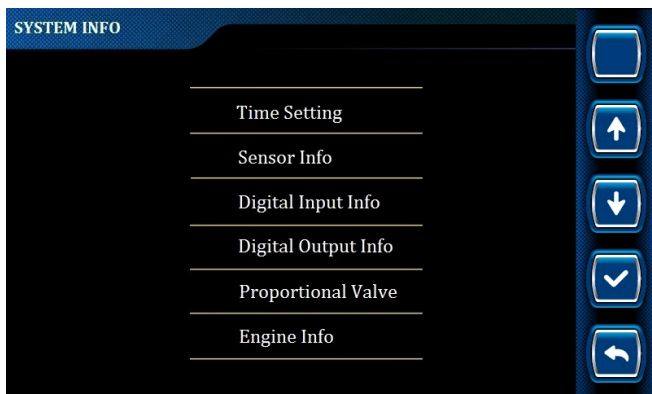


**Figure 7-21 TIME SETTING interface**

- On the TIME SETTING interface, select the desired setting option (the selected option will be flashing) through , change the value through and , and press to confirm the changing (there will be the icon at the top of the interface).
- Press successively to return to the main interface, and power off the machine as required.

## SYSTEM INFORMATION

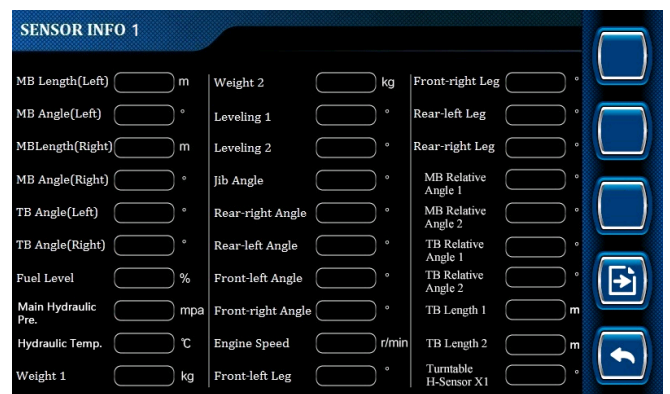
On the main interface, press to enter SYSTEM INFO interface.



**Figure 7-20 SYSTEM INFO interface**

## Sensor information

- The sensor information option is mainly used to query the actual value of the sensor configured on the machine, thus determining whether each sensor is working normally.
- The configuration of sensors is subject to the actual machine configuration.



**Figure 7-22 SENSOR INFO 1**

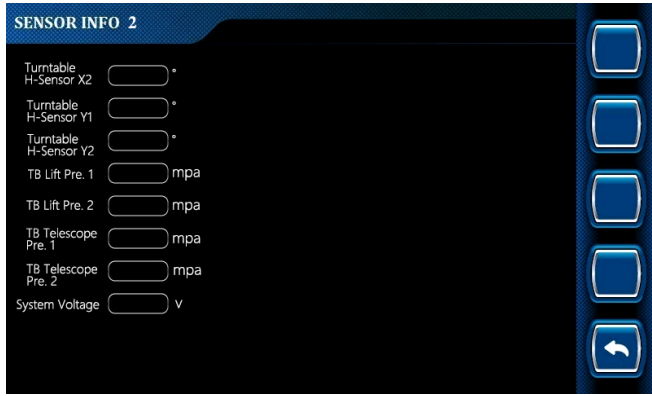


Figure 7-23 SENSOR INFO 2

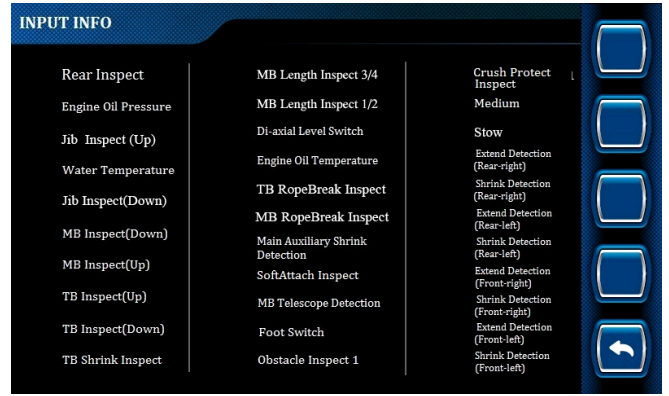


Figure 7-25 Input Info interface



Figure 7-24 SENSOR INFO 3

Digital input information

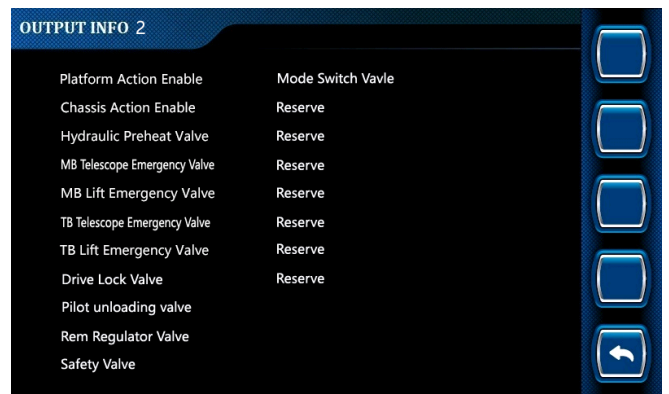
- The digital input information option is mainly used to query the signal detection status of detection switches (such as travel switches and proximity switches) configured on the machine (the icon before the option means that the switch has detected a signal, and the icon before the option means that the switch has not detected a signal), thus determining whether the detection switches are working normally and whether the working state of the machine meets the requirements.
- The configuration of switches is subject to the actual machine configuration.

Digital output information

- The digital output information option is mainly used to query the output status of the relays, switching valves and other output points configured on the machine (the icon before the option means that an output is detected, and the icon before the option means that no output is detected), thus assisting in determining the trouble causes.
- The configuration of output points is subject to the actual machine configuration.



Figure 7-26 OUTPUT INFO 1 interface



**Figure 7-27 OUTPUT INFO 2 interface**

## Proportional information

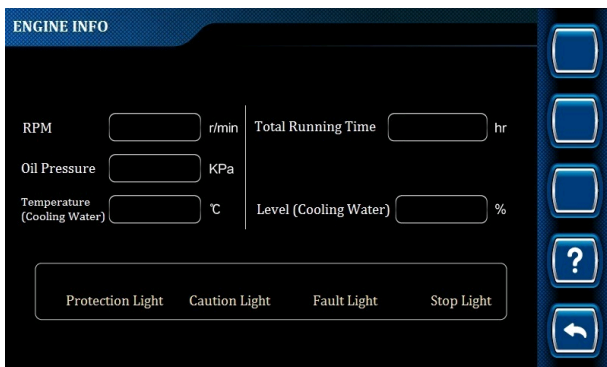
- The proportional information option is mainly used to query the output status of the proportional valve output points configured on the machine, thus assisting in determining the trouble causes
- The configuration of proportional valves is subject to the actual machine configuration.



**Figure 7-28 PROPORTIONAL INFO interface**

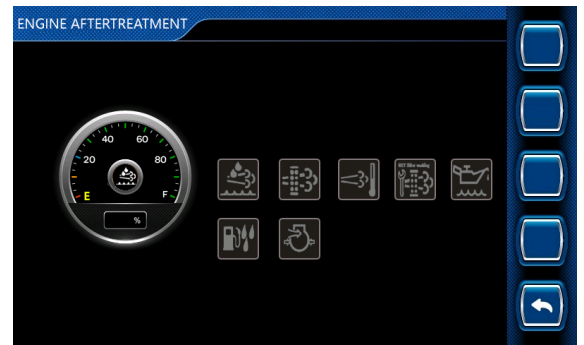
## Engine information (for models equipped with an engine)

- The machine information option is mainly used to query the status and fault information of the engine configured on the machine, so as to determine whether the engine is working normally.
  - The configuration of engine is subject to the actual machine configuration.
1. On the SYSTEM INFO interface, select Engine Info through and , and press to enter ENGINE INFO interface.



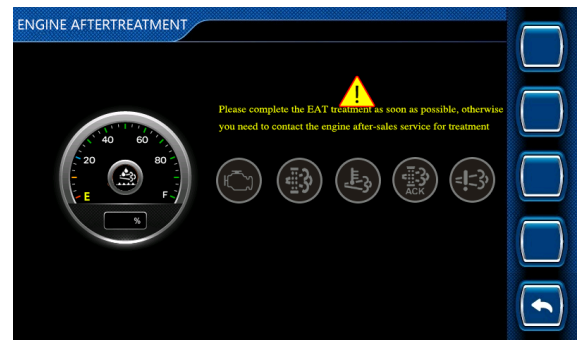
**Figure 7-29 ENGINE INFO interface**

2. On the ENGINE INFO interface, users can query the engine RPM, oil pressure, temperature (cooling water), total running time, level (cooling water), protection light, caution light, fault light and stop light.
3. On the ENGINE INFO interface, press to enter EAT INFO interface.
  - 1) If the machine does not need EAT, the status indicator will be off.



**Figure 7-30 EAT INFO interface (- without requiring EAT)-Equipped with Deutz engine**

- 2) For machines requiring EAT, if a yellow warning appears on the EAT INFO interface, and the status indicator light flashes, please perform EAT as indicated by the flashing indicator light as soon as possible.



**Figure 7-31 EAT INFO interface (with EAT not started)-Equipped with Yuchai or Yanmar engine**

- 3) If EAT is not completed within the specified time, a red warning will appear on the EAT INFO interface, and the status indicator light will be on. At this time, it is necessary to contact the engine manufacturer for EAT.

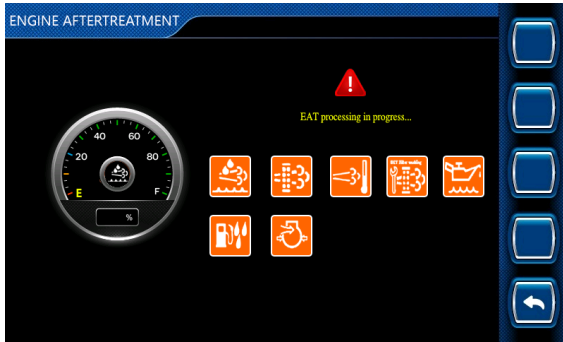


Figure 7-32 EAT INFO interface (with EAT started)-Equipped with Deutz engine

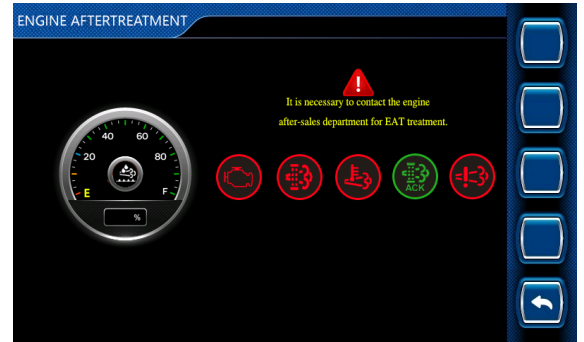


Figure 7-33 EAT INFO interface (with EAT started)-Equipped with Yuchai or Yanmar engine

Table 7-3 Descriptions of indicator lights for Deutz engine

No.	Indicator light	Status	Description	Symbol
1	SCR fault warning indicator light	Off	SCR system is working normally	
		Solid on	SCR system is faulted	
2	DEF level indicator light	Off	DEF level is normal	
		Solid on	DEF level is too low	
3	Standstill regeneration indicator light	Off	Standstill regeneration is not performed or requested	
		Solid on	Standstill regeneration is being performed	
		Slow flashing	Standstill regeneration is requested	
		Fast flashing	Standstill regeneration is requested, but since the driver has ignored the request for a long time, the standstill regeneration can only be completed through the DEUTZ diagnostic tool.	

4	Standstill regeneration/ high temperature indicator light	Off	Exhaust system temperature is normal	
		Solid on	Exhaust system temperature is abnormal	
5	DPF replacing required due to excessive ash content	Off	Ash content is normal	
		Solid on	Ash content is excessive	
6	Oil replacing required due to cumulative regeneration time too long	Off	Cumulative regeneration time is within the normal range	
		Solid on	Oil replacing is required due to cumulative regeneration time being too long	

**Table 7-4 Descriptions of indicator lights for Yuchai & Yanmar engines**

No.	Indicator light	Status	Description	Symbol
1	Engine malfunction indicator light	Off	Engine works normally	
		Solid on	Engine malfunctions	
2	Regeneration request indicator light (Yanmar)	Off	Regeneration is not requested and need not to be performed	
		Solid on	Regeneration is requested, with a reminder that regeneration must be performed	
	DPF regeneration reminder indicator light (Yuchai)	Off	Regeneration is not performed or requested	
		Solid on	The carbon content in DPF is too high, so it is recommended to perform parked regeneration	
		Slow flashi- ng	Since the carbon content in DPF is too high, perform parked regeneration or service regeneration immediately	
		Fast flashi- ng	Since DPF is heavily clogged, perform service regeneration immediately	
3	High exhaust temperature indicator light	Off	Exhaust system is at normal temperature	
		Solid on	Exhaust system temperature exceeds the set limit	
4	Regeneration execution indicator light	Off	Regeneration execution is inactive	
		Solid on	Regeneration function is being executed	
5	NCD indicator light (- Yanmar only)	Off	NCD is not working	
		Solid on	NCD is working	
6	Regeneration prohibiting indicator light (Yuchai only)	Off	Conditions prohibiting active regeneration do not exist	

		Solid on	ECU receives the set status of regeneration prohibiting switch, and active regeneration can't be performed	
--	--	----------	--	--

**Note:**

- When regeneration request indicator light flashes, a yellow warning will appear on the EAT INFO interface.
  - When regeneration request indicator light is solid on, a red warning will appear on the EAT INFO interface.
  - When regeneration execution indicator light (-green) is solid on, it indicates that regeneration is being performed at this time.
4. On the ENGINE INFO interface, press to enter ENGINE FAULT DIAGNOSES interface.



**Figure 7-34 ENGINE FAULT DIAGNOSES interface**

5. Press to query the detailed description of the main fault codes. For detailed fault descriptions, please refer to the Fault Code Description in the Maintenance Manual or the engine maintenance manual provided with the machine.
6. Press successively to return to the main interface, and power off the machine as required.

## TURNTABLE PANEL INFORMATION

- The turntable panel information option is mainly used to query the input status of switches on the ground controller panel, so as to check whether the circuit from the switches to the controller, input signal, etc. are normal, thus assisting in determining the trouble causes.
- The configuration of switches on the turntable panel is subject to the actual machine configuration.

On the main interface, press to enter the TURNTABLE PANEL INFO interface (the icon before the option means that the switch has input, and the icon before the option means that the switch has no input).



**Figure 7-35 TURNTABLE PANEL INFO interface**

## PLATFORM INFORMATION

- The platform information option is mainly used to query the input and output status of switches on the platform controller panel and the status of joystick on the platform, so as to check whether the circuit from the switches to the controller, input signal, etc. are normal, thus assisting in determining the trouble causes.
  - The configuration of switches on the platform panel and joystick is subject to the actual machine configuration.
1. On the main interface, press to enter the PLATFORM PANEL INFO interface to check the input status of switches on the platform controller panel (the icon before the option means that the switch has input, and the icon before the option means that the switch has no input). Press to check the output status of switches on the platform controller panel (the icon before the option means that the switch has output, and the icon before the option means that the switch has no output).

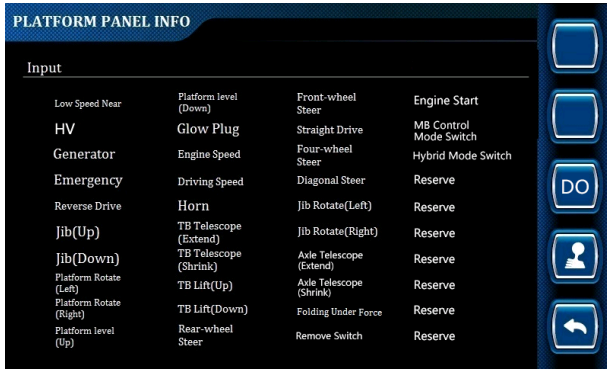


Figure 7-36 PLATFORM PANEL INFO interface-input

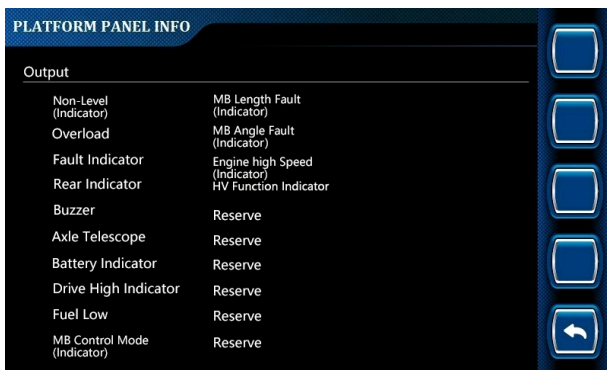


Figure 7-37 PLATFORM PANEL INFO interface-output

- On the PLATFORM PANEL INFO interface, press to enter the JOYSTICK INFO interface to query the actual value of joystick/potentiometer, so as to check whether the position status of joystick/potentiometer is normal.

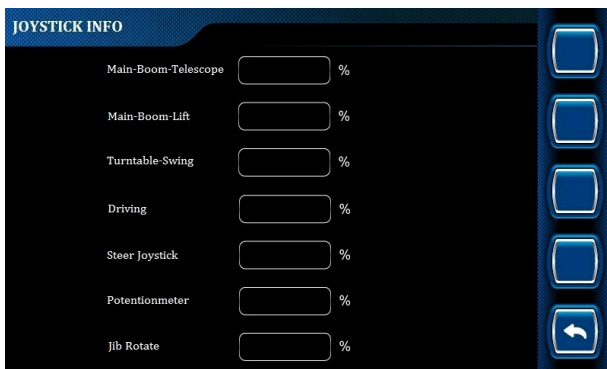


Figure 7-38 JOYSTICK INFO interface

- Press successively to return to the main interface, and power off the machine as required.

## ALARM INFORMATION

The alarm information option is mainly used to query the alarm or fault status of the control system, so as to determine the cause of fault and facilitate troubleshooting.

- On the main interface, press to enter the ALARM INFO interface. indicates that the CAN communication is normal, indicates that the CAN communication alarm is normal, and indicate other alarms, and indicate no input).

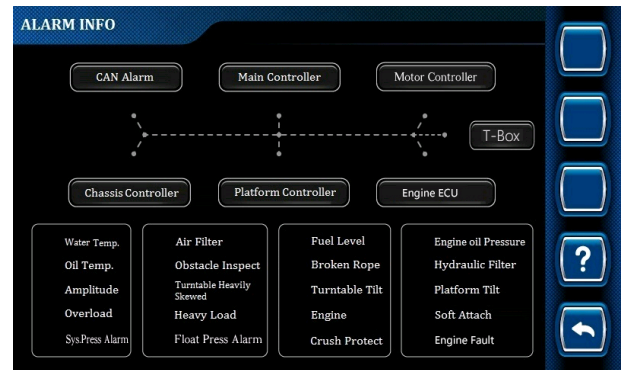
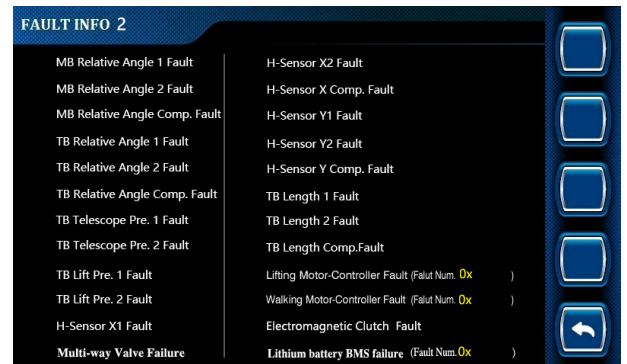


Figure 7-39 ALARM INFO interface



- On the ALARM INFO interface, press to enter FAULT INFO interface.



Figure 7-40 FAULT INFO interface 1



**Figure 7-41 FAULT INFO interface 2**

3. For the detailed description of faults codes of the lifting motor and travel motor controllers, please refer to the ***Fault Code Description for Electric Motor Controller*** in the Maintenance Manual (if the machine is equipped with a motor controller).
4. Lithium battery BMS fault Info: Press  to enter Lithium Battery BMS Fault Info interface to check the detailed description of lithium battery BMS fault codes. For the detailed fault description, please see ***BMS Fault Code Description for Lithium Battery*** section in the Maintenance Manual (if the machine is equipped with any lithium battery).
5. Press  successively to return to the main interface, and power off the machine as required.

**This Page Intentionally Left Blank**

# APPENDIX 1: PREPARE THE WORK RECORD BEFORE DELIVERY

PREPARE THE WORK RECORD BEFORE DELIVERY			
Model			
Serial No.			
Inspection Item	YES/Machine is in Good Condition	NO/Machine Has Damage or Malfunction	REPAIRED/Machine Has Been Repaired
Pre-operational Inspection			
Maintenance Procedure			
Functional Inspection			
Machine Buyer/ Renter			
Inspector Signature			
Inspector Title			
Inspector Company			
<p><b>NOTE:</b></p> <ol style="list-style-type: none"> <li>1. Prepare the machine before delivery, which includes performing a pre-delivery inspection, following maintenance procedures and performing functional inspections.</li> <li>2. Use the table to record the results. After each section is complete, mark the appropriate box.</li> <li>3. Record the inspection results. If any inspection result is "NO", the machine must be stopped, and then re-inspected after repair is completed, and the box marked "REPAIRED" shall be checked.</li> </ol>			

**This Page Intentionally Left Blank**

# APPENDIX 2 : REPAIR & INSPECTION REPORT

REPAIR & INSPECTION REPORT				
Model				
Serial No.				
<b>Checklist A Procedures</b>				
Items	YES/Machine is in Good Condition	NO/Machine Has Damage or Malfunction	REPAIRED/ Machine Has Been Repaired	Problem Description
A-1 Inspect All Manuals				
A-2 Inspect All Decals				
A-3 Inspect Damaged, Loose or Lost Parts				
A-4 Inspect Hydraulic Oil Level				
A-5 Inspect Hydraulic Oil Leakage				
A-6 Inspect Fuel Level				
A-7 Inspect Fuel Leakage				
A-8 Perform Oscillation Cylinder Exhausting				
A-9 Check Battery Level				
<b>Checklist B Procedures</b>				
Items	YES/Machine is in Good Condition	NO/Machine Has Damage or Malfunction	REPAIRED/ Machine Has Been Repaired	Problem Description
B-1 Inspect and Replace Hydraulic Oil Tank Return Filter Element				
B-2 Inspect Rim, Tire and Fasteners				
B-3 Inspect Hydraulic Oil				
B-4 Inspect Electrical Wiring				
B-5 Inspect Emergency Lowering				
B-6 Inspect Air Filter of Hydraulic Tank				

<b>REPAIR &amp; INSPECTION REPORT</b>				
B-7 Replace High-pressure Filter Element				
B-8 Test Driving Speed				
B-9 Inspect Length and Angle Sensors				
B-10 Inspect Tilt Protection				
B-11 Inspect Drive Reducer Oil Level				
B-12 Inspect Slewing Reducer Oil Level				
B-13 Inspect Slewing Bearing Bolts				
B-14 Lubricate Slewing Bearing				
B-15 Inspect Platform Oscillation Cylinder Fasteners				
B-16 Test Cylinder Drift				
B-17 Inspect Counterbalance Valve Locking				
B-18 Test Oscillation Outriggers and Oscillation Multi-way Valve Lever				
B-19 Inspect Battery				
B-20 Test Braking Distance				
<b>Checklist C Procedures</b>				
<b>Items</b>	<b>YES/Machine is in Good Condition</b>	<b>NO/Machine Has Damage or Malfunction</b>	<b>REPAIRED/ Machine Has Been Repaired</b>	<b>Problem Description</b>
C-1 Inspect Boom Extending/ Retracting Wire Ropes and Pulleys				
C-2 Replace Hydraulic Tank Air Filter				
C-3 Inspect Weighing System				
<b>Checklist D Procedures</b>				
<b>Items</b>	<b>YES/Machine is in Good Condition</b>	<b>NO/Machine Has Damage or Malfunction</b>	<b>REPAIRED/ Machine Has Been Repaired</b>	<b>Problem Description</b>
D-1 Replace Drive Reducer Gear Oil				

<b>REPAIR &amp; INSPECTION REPORT</b>				
D-2 Replace Slewing Reducer Gear Oil				
D-3 Replace Hydraulic Oil				
D-4 Replace Hydraulic Tank Suction Filter				
D-5 Inspect Boom Wear Pads				
User				
Inspector Signature				
Inspection Date				
Inspector Title				
Inspector Company				
<p><b>Note:</b></p> <ol style="list-style-type: none"> <li>1. The Repair &amp; Inspection Report shall include the inspection form of each regular inspection.</li> <li>2. Duplicate the Repair &amp; Inspection Report template for each inspection. Store the completed forms for 10 years or until the machine is no longer in use or as required by machine owner/company/custodian.</li> <li>3. Use the following table to record the results. After one item is complete, mark the appropriate box.</li> <li>4. Record the inspection results. If any inspection item is marked as "NO", the machine must be stopped and re-inspected after repair is completed and the box marked "REPAIRED" shall be checked.</li> </ol> <p>Select the appropriate inspection procedure based on the inspection type.</p>				

**This Page Intentionally Left Blank**



# Always for Better Access Solutions



## Hunan Sinoboom Intelligent Equipment Co., Ltd.

No.128, East Jinzhou Avenue, Ningxiang High-tech Industrial Park, Changsha, Hunan, China

☎ 0086-0731-87116222 (Sales) & 0086-0731-87116333 (Service)

✉ sales@sinoboom.com

🏠 www.sinoboom.com

### North American Subsidiary

#### Sinoboom North American LLC

310 Mason Creek Drive  
unit #100  
Katy, TX 77450, US  
Tel: (281) 729-5425  
E-mail: info@sinoboom.us

### Europe Subsidiary

#### Sinoboom B.V.

Nikkelstraat 26, NL-2984 AM Ridderkerk,  
The Netherlands  
Tel: +31 180 225 666  
E-mail: info@sinoboom.eu

### Korea Subsidiary

#### Sinoboom Korea Co., Ltd.

95, Docheong-ro, Yeongtong-gu, Suwon-  
si, Gyeonggi-do, Republic of Korea  
Tel: 010-8310-8026  
E-mail: ka1@sinoboom.com

### Australia Subsidiary

#### Sinoboom Intelligent Equipment Pty Ltd.

50/358 Clarendon St, South Melbourne  
VIC 3205, Australia  
E-mail: au@sinoboom.com

### Singapore Subsidiary

#### Star Access Solutions Pte. Ltd.

112 Robinson Road #03-01 Robinson 112  
Singapore 068902

### Poland Subsidiary

#### Sinoboom Poland sp. z o.o.

Ul. Bolesława Krzywoustego 74A  
61-144 Poznań, Poland