

Part No.501040110002
Rev: B
Oct 2021

Maintenance Manual

GTJZ0407SE/0407SE/1330SE

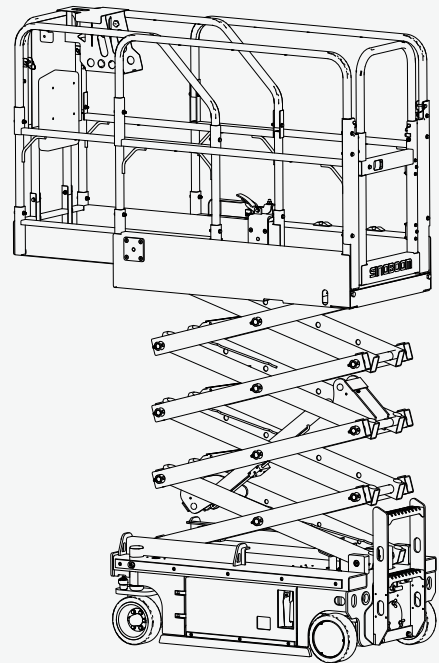

CE  AS/NZS  EAC GB 

SINOBOOM

 **WARNING**

Operating, servicing and maintaining this vehicle or equipment can expose you to chemicals including engine exhaust, carbon monoxide, phthalates, and lead, which are known to the State of California to cause cancer and birth defects or other reproductive harm. To minimize exposure, avoid breathing exhaust, do not idle the engine except as necessary, service your vehicle or equipment in a well-ventilated area and wear gloves or wash your hands frequently when servicing. For more information go to: www.P65warnings.ca.gov.

APPLICATION

Use the following table to identify the specific serial number for models included in this manual. Check the model of your machine before consulting the manual, and then use the correct manual according to the serial number of the model. See the nameplate on your machine to identify the model and serial number. (See *Decals/Nameplate Inspection* of the *Operation Manual* for details.)

MODELS	Trade identification		SERIAL NO.
	Metric	Imperial	
GTJZ0407SE	0407SE	1330SE	From 0104002940 to current

NOTE:

- Product model is applied in product nameplate for distinction of products of different main parameters.
- Product trade identification is applied in marketing and machine decals for distinction of products of different main parameters, and can be classified as metric type and imperial type: The metric type of trade identification is applicable to machines for countries/regions using metric system or as specially required by customers; The imperial type of trade identification is applicable to the machines for countries/regions using imperial system or as specially required by customers.

This Page Intentionally Left Blank

STATEMENTS

Hunan Sinoboom Intelligent Equipment Co., Ltd. (Hereinafter referred to as Sinoboom) will upload the latest product manual information to the website www.sinoboom.com as soon as possible. However, due to continuous product improvement, the information in this manual is subject to change without prior notice.

This manual covers the basic parts information of one or more products. Therefore, please use this manual according to your needs. If you find problems in the manual or have suggestions for improvement, feel free to share your feedback with Sinoboom, and we will address these issues as soon as possible.

Feel free to consult and download the *Operation Manual*, *Maintenance Manual* and *Parts Manual* of the products you need online at www.sinoboom.com.

Hunan Sinoboom Intelligent Equipment Co., Ltd. retains the right of final interpretation of the manual.

This Page Intentionally Left Blank

TABLE OF CONTENTS

Introduction	v	Machine Preparation, Inspection and Maintenance	4-1
1 Safety	1-1	General	4-1
Safety Definitions	1-1	Preparation, inspection and maintenance	4-1
Reporting Accidents	1-1	Qualified Sinoboom equipment mechanic	4-1
Electrocution Hazards	1-2	Pre-operation inspection	4-1
Tipping Hazards and Rated Load	1-2	Pre-delivery inspection and frequent inspection	4-1
Work Environment Hazards	1-4	Annual machine inspection	4-1
Unsafe Operation Hazards	1-5	Preventive maintenance	4-2
Fall Hazards	1-6	Storage	4-3
Collision Hazards	1-6	Maintenance and Servicing	
Crush Hazards	1-7	Precautions	4-3
Explosion and Fire Hazards	1-8	General	4-3
Damaged Machine Hazards	1-8	Safety and workmanship	4-3
Bodily Injury Hazards	1-8	Cleanliness	4-4
Battery Hazards	1-9	Component removal and installation	4-4
Welding and Polishing Requirements	1-10	Component disassembly and assembly	4-4
After Using the Machine	1-10	Scrap of structural parts	4-4
2 Specifications	2-1	Pressure-fit parts	4-5
Performance Parameters	2-1	Bearings	4-5
Power System Specifications	2-3	Gaskets	4-5
Hydraulic Hose and Fitting Specifications	2-4	Bolt usage and torque application ..	4-5
Hydraulic Hose Torque	2-4	Hydraulic lines and electrical wiring ..	4-5
Hydraulic Fitting Torque	2-4	Hydraulic system	4-5
Hydraulic Hose and Fitting Torque Procedure	2-7	Lubrication	4-5
Fastener Torque Specifications	2-7	Battery	4-5
3 System Descriptions	3-1	Pins and composite bearing	4-5
Power Source	3-1	Application of Insulating Silicone Grease to Electrical Connections	4-6
Hydraulic System	3-1	5 Maintenance	5-1
Electrical System	3-1	Conducting a Pre-delivery Inspection ..	5-1
Machine Control System	3-1		
Safety Measures	3-1		
4 Service and Guidelines	4-1		

Following a Maintenance Schedule ...	5-2
Completing a Repair & Inspection Report.....	5-2
Checklist A Procedures	5-4
A-1 Inspect All Manuals.....	5-4
A-2 Inspect All Decals	5-5
A-3 Inspect Damaged, Loose or Lost Parts	5-5
A-4 Inspect Hydraulic Oil Level	5-5
A-5 Inspect Hydraulic Oil Leakage..	5-6
A-6 Functional Tests	5-6
A-7 Inspect the Battery Level	5-9
A-8 Perform Maintenance After 30 Days	5-9
Checklist B Procedures	5-9
B-1 Inspect Electric Wires	5-9
B-2 Inspect Rim, Tire and Fasteners	5-10
B-3 Inspect Battery	5-12
B-4 Inspect Hydraulic Oil	5-12
B-5 Inspect Hydraulic Oil Tank Air Filter	5-13
B-6 Inspect Brake Manual Release Function	5-13
B-7 Inspect Emergency Lowering Function	5-14
B-8 Test Braking Device	5-14
B-9 Test Full Lift/Lower Time	5-15
B-10 Test Drive Speed.....	5-15
B-11 Inspect the Tilt Protection Function	5-16
B-12 Inspect Pothole Guards	5-17
Checklist C Procedures	5-17
C-1 Replace Hydraulic Oil Tank Air Filter	5-17
C-2 Inspect Platform Weighing System(optional).....	5-18
Weight calibration (DTC system)	5-18
C-3 Inspect Up Limit Switch	5-18

C-4 Inspect Staged Lowering	5-19
Checklist D Procedures	5-19
D-1 Inspect Scissor Arm Installation Bearing	5-19
D-2 Inspect Chassis Slider	5-19
D-3 Replace Hydraulic Oil	5-19
6 Repair.....	6-1
Platform Components	6-1
Platform Controller.....	6-1
Removing the Platform	6-1
Removing the Extension Platform ..	6-2
Scissor Components	6-2
Removing the Scissor Arm	6-2
Lift Cylinder	6-2
Chassis Components	6-3
Tires and Rims.....	6-3
Removing the Reducer & Drive Motor	6-4
Removing the Front Wheel Bracket	6-4
Steer Cylinder	6-5
Battery	6-5
Battery	6-5
Hydraulic System	6-6
Hydraulic Power Unit	6-6
Lift Control Valve Assembly.....	6-7
Regulating Platform Lift Relief Valve Pressure.....	6-8
Adjusting the Emergency Lowering Handle	6-8
Hydraulic Symbols	6-9
Hydraulic Schematic Diagram	6-10
Electrical System.....	6-11
Use and Maintenance of Battery...	6-11
Charger Troubleshooting	6-13
Trouble Diagnosis	6-13
Fundamental Troubleshooting	6-21
Electrical Symbols	6-24
Electrical Schematic(DTC-K300 & CANPLUS)	6-26

Electrical Schematic (DTC-K500/
SINOBOOM).....6-28

Appendix 1: Prepare the Work

Record Before Delivery A-1

Appendix 2: Repair & Inspection

Report A-3

INTRODUCTION

Thank you for choosing and using the machinery of Hunan Sinoboom Intelligent Equipment Co., Ltd. Always read, understand and become familiar with the operation requirements of the machine and its associated safety procedures before operating, maintaining and repairing the machine. Operating the machine without becoming familiar with its specific operation requirements and safety procedures poses serious risks. Operators who follow safety rules and operate the machine carefully and effectively will prevent personal injury, property loss and accidents.

Use this machine only to transport tools to work locations and for performing tasks on the work platform. Operators must be competent and must obtain training to carefully use the machine and follow safety procedures. Only trained and authorized personnel may operate the machine.

This manual guides the operator and authorized personnel in maintaining the machine. The operator is responsible for reading, understanding and implementing the maintenance and safety procedures in this manual and for following the manufacturer's instructions before beginning any work. Read, understand and follow all safety rules and operating instructions. The operator must also consider the machine's uses and limitations and the conditions at the jobsite before using this machine. Strictly following all safety requirements in this manual is critical.

Consider this manual a part of the machine, along with *Operation Manual* and *Parts Manual*, and always keep the manuals with the machine. The owner or administrator of the machine shall offer all manuals and other necessary information provided by the machine manufacturer regarding the daily inspection and maintenance to each of the renters. If the machine is sold, the owner or administrator must pass along the manuals and other necessary information to the purchaser. The owner or administrator of the machine shall also provide the manufacturer's maintenance information to the person responsible for maintaining the machine.

If you have any questions, contact Hunan Sinoboom Intelligent Equipment Co., Ltd..

This Page Intentionally Left Blank

1 SAFETY

Read, understand and comply with the safety rules and regulations of your workplace and your government.

Before using the machine, ensure the operator is properly trained and qualified in safely operating the machine. The training includes but is not limited to :

- Warning and instruction decals on the machine
- Pre-operation inspection
- Any factors that may affect the machine stability
- Common hazards and countermeasures
- Jobsite inspection
- Functions of all controls and associated knowledge, including emergency control.
- Personal protection equipment that suits the task, workplace and environment.
- Safety operation
- Transporting the machine
- Measures against unauthorized use
- Operating instructions

Understand that as the operator you have the responsibility and right to shut down the machine in case of failure with the machine or other emergency at your workplace.

NOTICE

People suffering from heart disease, hypertension, epilepsy and other diseases and people who fear heights must never operate or use this machine. Also, people who have alcohol or drugs in their system, or experience excessive fatigue or depression, are prohibited from operating or using this machine.

SAFETY DEFINITIONS



This safety alert symbol appears with most safety statements. It means attention, become alert, your safety is involved! Please read and abide by the message that follows the safety alert symbol.

DANGER

Indicates a hazardous situation that, if not avoided, **will** result in death or serious injury.

WARNING

Indicates a hazardous situation that, if not avoided, **could** result in death or serious injury.

CAUTION

Indicates a hazardous situation that, if not avoided, **could** result in minor or moderate injury.

NOTICE

Indicates a situation that can cause damage to the engine, personal property and/or the environment, or cause the equipment to operate improperly.

NOTE: Indicates a procedure, practice or condition that should be followed in order for the engine or component to function in the manner intended.

REPORTING ACCIDENTS

In case of any accident involving the machinery of Hunan Sinoboom Intelligent Equipment Co., Ltd., notify Hunan Sinoboom Intelligent Equipment Co., Ltd. Immediately, even if no personal injury or property damage occurs during the accident. Contact Hunan Sinoboom Intelligent Equipment Co., Ltd. by telephone and provide all necessary details. Failure to notify the manufacturer within 48 hours of the incident involving the machinery of Hunan Sinoboom Intelligent Equipment Co., Ltd. may void the product's warranty.

NOTICE

Thoroughly inspect the machine and all its functions after any accident, being sure to test first from the ground controller and then from the platform controller. Ensure the machine's lifting height does not exceed 3 m(9.8 ft) until all damage has been repaired and all controllers operate properly.

ELECTROCUTION HAZARDS

NOTE: This machine is not insulated and does not have an electric shock protection function.

All operators and managers shall comply with national or local regulations regarding the minimum safe distance of live conductors above the ground. In the absence of such requirements, operators and managers should follow the minimum safety distance requirements in [Table 1-1 Minimum Safe Distance, page 1-2](#).

WARNING

ELECTRICAL SHOCK HAZARDS





- Always maintain a safe distance from power lines and electrical equipment in accordance with applicable government regulations and see [Table 1-1 Minimum Safe Distance, page 1-2](#).
- Consider platform movement, wire swinging or drooping, beware of strong winds or gusts, and do not operate the machine when there is lightning or heavy rain.
- If the machine comes into contact with live wires, keep away from the machine. Personnel on the ground or on the platform must not touch or operate the machine until the power is switched off.
- Do not use the machine as a ground wire during welding and polishing operations.

TIPPING HAZARDS AND RATED LOAD

Maximum rated load bearing capacity of the platform:

Table 1-2

GTJZ0407SE	
Retracting	240 kg (526 lb)
Extending: Stationary only	140 kg (306 lb)
Extending: Extension only	100 kg (220 lb)

Table 1-1 Minimum Safe Distance

Voltage (Phase to Phase, kV)	Minimum Safe Distance (m/ft)
0-50	3.05 (10)
50-200	4.60 (15)
200-350	6.10 (20)
350 -500	7.62 (25)
500 -750	10.67 (35)
750 -1000	13.725 (45)

 **WARNING**

TIPPING HAZARDS



- Personnel, equipment and materials on the platform must not exceed the maximum load capacity.
- Only raise or extend the platform when the machine is on solid, level ground.
- Do not use the tilt alarm as a level indicator. The tilt alarm on the platform will sound only if the machine is heavily tilted. If the tilt alarm sounds:
 - Be very careful to lower the platform. Transfer the machine to solid, level ground. Do not change the level or limit switch.
- Do not drive faster than 0.8 km/h (0.5 mph) when the platform is raised.
- When the platform is raised, the machine cannot travel on uneven terrain, unstable surfaces or in other dangerous conditions.
- Do not operate the machine during strong winds or gusts, and do not increase the surface area of the platform or load. Increasing the area exposed to the wind will reduce the stability of the machine.
- When the machine is on rough ground, with gravel or other uneven surfaces, or near holes and steep slopes, use caution and reduce the speed.
- When on the platform do not push and pull objects outside of it. The maximum lateral force allowed for indoors is 400 N(90 lbf).
- Do not change any machine parts that may affect safety and stability.
- Do not replace key parts that affect machine stability with different weights or specifications.
- Do not modify or change moving aerial platforms without the manufacturer's prior written permission.
- On the platform, do not attach an additional device for placing tools

 **WARNING**

TIPPING HAZARDS

- or other materials to the guardrail. This will increase the platform weight, surface area and load.
- Do not place on, or fasten to, any overhanging load to any part of this machine.
- Do not place ladders or scaffolding on the platform or any parts of the machine.
- Do not use the machine on a moving or active surface or on a vehicle. Ensure all tires are in good condition, the slotted nuts tightened and the cotter pins complete.
- Do not use a battery that weighs less than the original battery(33 kg [73 lb]). The battery not only provides power, it also serves as a counterweight. The battery is vital to maintaining the stability of the machine.
- Do not use a platform to propel machines or other objects.
- Do not let the platform touch nearby objects.
- Do not tie off the platform with rope or other binding materials to nearby objects.
- Do not put a load outside the platform.
- Do not operate the machine when the chassis doors are open.
- When the platform is caught or stuck or when other objects in the vicinity impede its normal movement, do not use the platform controller to lower the platform. If you intend to lower the platform with a ground controller, you must operate it only after all personnel have left the platform.

WORK ENVIRONMENT HAZARDS

WARNING

UNSAFE JOBSITE HAZARDS

- Do not operate the machine on surfaces, edges or potholes that cannot bear the weight of the machine. Raise or extend the platform only when the machine is on firm, flat ground.
- Do not use the tilt alarm as a horizontal indicator. The tilt alarm on the platform will sound only when the machine is heavily tilted.
- If the tilt alarm sounds while lifting the platform, be very careful when lowering the platform. Do not change the level or limit switch.
- Running speed should not exceed 0.8 km/h (0.5 mph) when the platform rises.

WARNING

UNSAFE JOBSITE HAZARDS

- Never travel on uneven terrain or unstable surfaces or in other dangerous conditions when raising the platform.
- When the machine retracts, be careful and slow down when the machine is moving on uneven terrain, crushed stone, unstable or smooth surfaces, steep slopes and near cave entrances.
- Do not drive or lift the machine on slopes, steps or vaulted surfaces that exceed the maximum climbing capacity of the machine.

Before or during machine operation, check the possible hazards on the jobsite and beware of the restrictions within the environment, including flammable and explosive gas/dust. If the machine is used in any other applications, or by any other means, as specified by **Sinoboom**, it must be approved or guided by the manufacturer.

Table 1-3

BEAUFORT NUMBER	METERS/ SECOND	MILE/ HOUR	DESCRIPTION	GROUND CONDITION
0	0 ~ 0.2	0 ~ 0.5	Calm	Calm. Smoke rises vertically.
1	0.3 ~ 1.5	1 ~ 3	Light air	Wind motion visible in smoke.
2	1.6 ~ 3.3	4 ~ 7	Light breeze	Wind felt on exposed skin. Leaves rustle.
3	3.4 ~ 5.4	8 ~ 12	Gentle breeze	Leaves and smaller twigs in constant motion.
4	5.5 ~ 7.9	13 ~ 18	Moderate breeze	Dust and loose paper rise. Small branches begin to move.
5	8.0 ~ 10.7	19 ~ 24	Fresh breeze	Smaller trees sway.
6	10.8 ~ 13.8	25 ~ 31	Strong breeze	Large branches in motion. Flags waving near horizontal. Umbrella use becomes difficult.
7	13.9 ~ 17.1	32 ~ 38	Near gale/moderate gale	Whole trees in motion. Effort needed to walk against the wind.
8	17.2 ~ 20.7	39 ~ 46	Fresh gale	Twigs broken from trees. Cars veer on road.
9	20.8 ~ 24.4	47 ~ 54	Strong gale	Light structure damage.

NOTICE

Maximum climbing ability is suitable for machines with platform retracted.

Maximum Slope:

GTJZ0407SE: 25% (14°)

Climbing capacity means the maximum allowable tilt angle of the machine when it is on solid ground and the platform is only capable of carrying one person. As the weight of the machine's platform increases, the machine's climbing capacity reduces.

UNSAFE OPERATION HAZARDS

At a minimum, operators must operate and maintain the machine as stated in this manual and in the *Operation Manual* in addition to following more stringent industry regulations and workplace rules. Never engage in unsafe machine operation.

Do not use the machine in the following situations :

- Unrelated personnel/equipment is present in the working envelope of the machine.
- Use as a crane (except the custom-made ones with such functions).
- Use on the truck, trailer, tracked vehicle, ship, scaffold and the like without written consent by the manufacturer or a qualified professional.
- Improper securing of the machine to another object by just sitting it against, fastening or binding.
- Stunt or imprudent use of the machine.
- Overloaded or overmoment situation.
- Other situations as specified in the Manuals.

⚠ WARNING

UNSAFE OPERATION HAZARDS



- Do not push any object outside the platform. The maximum lateral force allowed for indoors is 400 N (90 lbf).
- Do not change any machine parts that may affect safety and stability.
- Do not replace key parts that affect machine stability with different weights or specifications.
- Do not change or modify moving aerial platforms without the manufacturer's written permission.
- On the platform, do not attach an additional device for placing tools or other materials to the guardrail. This will increase the platform weight, surface area and load.
- Do not put ladders or scaffolding on the platform or any part of this machine.
- Do not use the machine on any mobile or movable surface or vehicle. Ensure all tires are in good condition, the slotted nuts tightened and the cotter pins complete.
- Do not use a battery that weighs less than the original battery (33 kg [73 lb]). The battery not only provides power, it also serves as a counterweight. The battery is vital to maintaining the stability of the machine.
- Do not place or attach any suspended load onto any part of the machine.
- Do not use the machine as a crane.
- Do not use the platform to push the machine or other objects.
- Do not allow the platform to touch nearby objects.
- Do not tie the platform onto nearby objects.
- Do not put the load outside the platform.
- When the platform is caught or stuck or when other objects in the vicinity impede its normal

⚠ WARNING

UNSAFE OPERATION HAZARDS

movement, do not use the platform controller to lower the platform. If you intend to lower the platform with a ground controller, you must operate it only after all personnel have left the platform.

- Do not operate the machine when the chassis door box is open.
- When one or more of the machine's tires are off the ground, evacuate all personnel before attempting to stabilize the equipment. Use a crane, forklift or other suitable apparatus to stabilize the equipment.

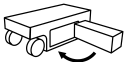

⚠ WARNING

FALL HAZARDS



- Each person on the platform must wear harnesses or use safety equipment consistent with government regulations. Fasten the cable to the fixed point of the platform. Never fasten the cable of more than one person to a fixed point on the platform.
- Do not sit, stand or crawl on the guardrails. When on the platform always remain standing on the platform floor.
- Do not climb down from the platform when the platform is elevated.
- Keep the platform floor free of obstacles.
- Do not enter or exit the platform unless the machine is fully in place.
- Close the platform entrance door before operating the machine.
- Do not operate the machine if the handrails are not properly installed and the platform entry door is not closed.

FALL HAZARDS

At a minimum, operators must operate and maintain the machine as stated in *Operation Manual* and in the *Maintenance Manual* in addition to following more stringent industry regulations and workplace rules.

COLLISION HAZARDS

At a minimum, operators must operate and maintain the machine as stated in this manual and in the *Maintenance Manual* in addition to following more stringent industry regulations and workplace rules.

⚠ WARNING

COLLISION HAZARDS



- Pay attention to the field of sight and the presence of blind spots when moving or operating the machine.
- Pay attention to the extended platform when moving the machine.
- Check the work area to avoid ground and overhead obstructions or other possible risks.
- Be sure to exercise caution when using the platform controller and chassis controller. Color-marked directional arrows show the function of travel, lift and steering.
- Users must comply with user, workplace and government rules regarding the use of personal protective equipment (hard hats, safety belts and gloves, etc.).
- Place the machine on level ground or in a secured position before releasing the brakes.
- Only lower the platform when there are no people or obstructions in the area beneath it.
- Limit the speed of travel according to ground conditions, crowding, gradients, the presence and location of personnel and any other factors that may cause collisions.
- Do not operate the machine on any crane or overhead traveling device unless the crane control is locked or precautions have been taken to prevent any potential collision.
- Do not place your hands and arms where they may become crushed or trapped.
- Do not work in or under the platform or near the scissor arms when the safety lever is not in place.
- Maintain good judgment and planning when using the controller on the ground to operate the machine. Maintain proper distance between operator, machine and fixed object.

⚠ WARNING

COLLISION HAZARDS

- Never operate a machine dangerously or for fun.

CRUSH HAZARDS

A potential crush hazard exists during movement of the machine. Always keep body parts and clothing a safe distance from the machine during machine operation.



⚠ WARNING

CRUSH HAZARDS





- Do not place your hands and arms where they may become crushed or trapped.
- Do not work in or under the platform or near the scissor arms when the safety lever is not in place.
- Maintain good judgment and planning when using the controller on the ground to operate the machine. Maintain proper distance between operator, machine and fixed object.

EXPLOSION AND FIRE HAZARDS

 WARNING	
EXPLOSION AND FIRE HAZARD	
	<ul style="list-style-type: none"> Do not use the machine or charge the battery in hazardous or potentially flammable or explosive atmospheres.
	<ul style="list-style-type: none"> For the engine-powered machines, never add fuel while the engine is still running, and only add fuel when the place is well ventilated and free of flame, spark or any other hazards that may cause explosion. Never spray ether on the engine equipped with glow plug.



DAMAGED MACHINE HAZARDS

NOTICE
<p><i>To avoid machine damage, follow all operation and maintenance requirements in this manual and the Maintenance Manual.</i></p>

 WARNING	
UNSAFE OPERATION HAZARDS	
	<ul style="list-style-type: none"> Do not use the machine if it is damaged or not in proper operating condition. Thoroughly inspect and test for all functions of the machine before use. Immediately mark and stop damaged or faulty machines. Ensure that all maintenance operations have been performed in accordance with this manual and the corresponding <i>Maintenance Manual</i>. Make sure all labels are in place and are legible. Ensure that the <i>Operation Manual</i> and <i>Maintenance Manual</i> are sound, easy to read and stored in the storage compartment on the platform.

BODILY INJURY HAZARDS

Always follow all operation and maintenance requirements in this manual and the .



 WARNING	
UNSAFE OPERATION HAZARD	
	<p>Do not operate the machine when there are oil spills/leaks. Oil spills or leaks in hydraulic fluids may penetrate and burn the skin.</p>

NOTE: The operator must carry out maintenance during the pre-operation inspection only. During operation, keep the left and right doors of the chassis closed and locked. Only trained service personnel can open the left and right doors to repair the machine.

BATTERY HAZARDS

⚠ WARNING

FIRE AND EXPLOSION HAZARD

- Batteries contain sulfuric acid and generate explosive mixtures of hydrogen and oxygen gases. Keep any device that may cause sparks or flames (including cigarettes/smoking materials) away from the battery to prevent explosion.
- Do not touch the battery terminals or cable clips with tools that may cause sparks.

⚠ WARNING

BATTERY HAZARD



Always wear protective glasses or goggles and protective clothing when working with batteries. Remove all rings, watches and other accessories.

⚠ WARNING

CHEMICAL BURN HAZARD



Avoid spilling or contacting battery acid with unprotected skin. Seek medical attention immediately if battery acid contacts skin.

⚠ WARNING

BATTERY HAZARD



- Only connect the charger to a grounded 3–wire AC outlet. Be sure the charger is in proper operating condition before charging.
- Only use the charger provided with the machine by the manufacturer.
- Ensure the place where the battery is charged is well ventilated and far away from sunlight, flame, spark or any other hazards that may cause explosion, and do not expose the battery to the water or rain.
- Only the properly trained personnel authorized by the workplace are allowed to remove the battery from the machine.
- Be sure to use the appropriate number of personnel and proper lifting methods when changing the battery.
- During the assembling or disassembling process, never use the battery in a forcible manner, and never allow the battery to fall off.
- Never directly short-circuit the battery outputs with electrical cords.
- Should the battery acid spill out, use bicarbonate (baking soda) mixed with water to neutralize the acid.
- Never store the battery in water or humid atmosphere.
- Daily check the battery cable for damage, and replace any damaged parts before operating the machine.

⚠ WARNING**LITHIUM BATTERY HAZARD**

- Only use the dedicated charger to charge the battery.
- Do not allow lens, needles or other sharp objects to contact with the battery, otherwise the battery membrane will easily get damaged.
- Do not immerse the battery into the sea or water for an extended period of time.
- Do not use the machine with the battery close to a heat source (- fire, heater, etc).
- Do not use the battery with the positive or negative terminals installed inversely.
- Do not directly connect the battery to a power outlet .
- Do not throw the battery into a fire or heater,

NOTICE

After charging the battery, be sure that:

- *The battery cable connections are free of corrosion.*
- *The battery hold-down and cable connections are secured.*

Adding terminal protection and anti-corrosion sealants will help reduce corrosion of the battery terminals and cables.

WELDING AND POLISHING REQUIREMENTS

Before welding, grinding and polishing operations, always ensure you read and understand all operation and maintenance requirements in this manual and the *Maintenance Manual*.

⚠ WARNING**WELDING HAZARDS**

- Comply with the welder manufacturer's recommendations for procedures concerning proper use of the welder.
- Welding leads or cables may only be connected after turning off the power unit.
- Carry out welding operations only after the welding cable has been correctly connected.
- Do not use the machine as a ground wire during welding operation.
- At all times, make sure that the power tools are completely stored in the working platform. Do not hang the power tools on the railing of the working platform or the work area outside the working platform, or hang the power tools directly by the wire.

Before performing welding, grinding and polishing work, welders must seek permission of the responsible department at the workplace.

AFTER USING THE MACHINE

1. Choose a safe parking location that is on sturdy, level ground and that is free of obstructions. Avoid areas with heavy traffic.
2. Lower the platform.
3. Turn the emergency stop switch of the ground controller to the "OFF" position
4. Turn the key switch to the "OFF" position and remove the key to avoid unauthorized use of the machine.
5. Block the wheels with the wheel wedges.
6. Charge the battery.

NOTICE

After using the machine, the power off switch must be disconnected.

2 SPECIFICATIONS

PERFORMANCE PARAMETERS

Table 2-1 GTJZ0407SE Specifications

MEASURE	0407SE (METRIC)	1330SE (IMPERIAL)
DIMENSION PARAMETERS		
Max. platform height	3.8 m	12.5 ft
Max. working height	5.8 m	19 ft
Max. horizontal extension	0.6 m	2 ft
Length	1.42 m	4.67 ft
Width	0.76 m	2.5 ft
Height (stowed, rails folded)	1.67 m	5.5 ft
Height (stowed, rails up)	1.97 m	6.5 ft
Wheel base	1.11 m	3.6 ft
Wheel span	0.7 m	2.2 ft
Ground clearance (pothole guards retracted)	65 mm	2.6 in.
Ground clearance (pothole guards deployed)	20mm	0.75 in.
Tire size (diameter × width / type)	Φ230×80 mm/Solid	Φ9×3.1 in./Solid
Platform dimension (Length × Width × height)	1.34×0.7×1.1m	4.4×2.3×3.6 ft
PERFORMANCE PARAMETERS		
Rated load capacity of platform	240 kg	529 lb
Max. load capability of extended platform	100 kg	220 lb
Max. platform occupancy(indoor only)	2-person	
Drive speed (stowed)	0 ~ 4 km/h	0 ~ 2.5 mph
Drive speed (raised)	0 ~ 0.8 km/h	0 ~ 0.5 mph
Uptime (in a no-load state)	30 ~ 33 s	
Downtime (in a no-load state)	25 ~ 30 s	
Gradeability	25%	
Max. allowable inclination	3°(Front to back)/1.5°(Left to right)	
Turning radius (inside)	0.3 m	1 ft

MEASURE	0407SE (METRIC)	1330SE (IMPERIAL)
Turning radius (outside)	1.35 m	4.4 ft
Max. allowable manual force (indoor only)	400 N	90 lbf
Max. noise	72dB	
POWER PARAMETERS		
Hydraulic tank capacity	4 L	0.88 gal(imperial)/1.05 gal(US)
Hydraulic system capacity (including tank)	5 L	1.1 gal(imperial)/1.32 gal(US)
Hydraulic system pressure	14 MPa	2030 Psi
Battery specification (quantity × voltage, capacity)	2×12V,115Ah	
Power system voltage	24VDC	
System control voltage	24VDC	
GROUND BEARING DATA		
Max wheel load	500 kg	1102 lb
Pressure against ground	1000 KPa	145 Psi
ENVIRONMENTAL REQUIREMENT		
Max. allowable wind speed (indoor only)	0	0
Max. allowable altitude	1000m	3281 ft
Allowable ambient temperature (lead-acid batteries)	-10°C to 40°C	14°F to 104°F
Allowable ambient temperature (lithium batteries)	-20°C to 40°C	-4°F to 104°F
Max. allowable ambient relative humidity	90%	
Storage condition	Stored at -20°C to 50°C(-4°F to 122°F) in a well-ventilated environment with 90% relative humidity (20°C [68°F]), and away from rain, sun, corrosive gas and inflammable explosive.	
WEIGHT		
Weight (in a no-load state) (indoor only)	880 kg	1941 lb

NOTE:

- a) The working height adds 2m (6ft 7in) of human height to platform height.
- b) In different areas, hydraulic oil, engine oil, coolant, fuel and lubrication should be added in accordance with the environmental temperature.
- c) In cold weather, auxiliary devices are needed to start the machines.
- d) The ground bearing data is approximate values not considering different options and only used when it is safe enough.
- e) The loads of persons, accessories, tools and materials are factored into the rated platform capacity.

POWER SYSTEM SPECIFICATIONS

Table 2-2

MEASURE	SPECIFICATIONS
HYDRAULIC OIL	
Normal temperature region (32°F ~ 104°F [0°C ~ 40°C])	L-HM46
Cold region (-13°F ~ 77°F [-25°C ~ 25°C])	L-HV32
Hot region (>104°F [40°C])	L-HM68
Extremely cold region (<-22°F [-30°C])	Special scheme to be determined
HYDRAULIC PUMPS	
Type	Gear pump
Displacement	1.1ml/r
Maximum driving pressure	25MPa (3626Psi)
DRIVE REDUCER & MOTOR	
Voltage	24V
Speed ratio	47.1
Power	1.6kW (2.1 HP)

NOTICE

Different hydraulic oils can be added according to customer requirements upon factory delivery, but cannot be mixed.

HYDRAULIC HOSE AND FITTING SPECIFICATIONS

HYDRAULIC HOSE TORQUE

Hydraulic hoses must be torqued to the following specifications.

Table 2-3 Hydraulic Hose Torque

METRIC THREAD	L (LIGHT-DUTY)	S (HEAVY-DUTY)
M12 × 1.5	19 ± 1 Nm (14 ± 1 ft-lb)	
M14 × 1.5	26 ± 2 Nm (19 ± 2 ft-lb)	
M16 × 1.5	40 ± 3 Nm (30 ± 2 ft-lb)	
M18 × 1.5	50 ± 4 Nm (37 ± 3 ft-lb)	
M20 × 1.5	-	60 ± 4 Nm (44 ± 3 ft-lb)
M22 × 1.5	70 ± 5 Nm (52 ± 4 ft-lb)	-
M24 × 1.5	-	85 ± 6 Nm (63 ± 4 ft-lb)
M26 × 1.5	90 ± 6 Nm (66 ± 4 ft-lb)	-
M30 × 2	120 ± 8 Nm (89 ± 6 ft-lb)	140 ± 10 Nm (103 ± 7 ft-lb)
M36 × 2	150 ± 12 Nm (111 ± 9 ft-lb)	180 ± 12 Nm (133 ± 9 ft-lb)
M42 × 2	-	260 ± 16 Nm (192 ± 12 ft-lb)
M45 × 2	240 ± 15 Nm (177 ± 11 ft-lb)	-
M52 × 2	250 ± 16 Nm (184 ± 12 ft-lb)	280 ± 18 Nm (207 ± 13 ft-lb)

HYDRAULIC FITTING TORQUE

Hydraulic fittings with metric thread must be torqued to the following specifications.

Table 2-4 Hydraulic Fitting Torque – Metric

THREAD SIZE	INSTALLED INTO ALUMINUM	INSTALLED INTO STEEL	
	ED, O-RING + CIRCLIP	ED, O-RING + CIRCLIP	O-RING
L (LIGHT-DUTY)			
M10×1	18 ± 1 Nm (13 ± 1 ft-lb)	20 ± 2 Nm (15 ± 2 ft-lb)	18 ± 1 Nm (13 ± 1 ft-lb)
M12×1.5	30 ± 2 Nm (22 ± 2 ft-lb)	35 ± 2 Nm (26 ± 2 ft-lb)	30 ± 2 Nm (22 ± 2 ft-lb)
M14×1.5	42 ± 3 Nm (31 ± 2 ft-lb)	48 ± 4 Nm (35 ± 3 ft-lb)	35 ± 2 Nm (26 ± 2 ft-lb)
M16×1.5	55 ± 4 Nm (41 ± 3 ft-lb)	60 ± 4 Nm (44 ± 3 ft-lb)	40 ± 3 Nm (30 ± 3 ft-lb)

THREAD SIZE	INSTALLED INTO ALUMINUM	INSTALLED INTO STEEL	
	ED, O-RING + CIRCLIP	ED, O-RING + CIRCLIP	O-RING
M18×1.5	75 ± 5 Nm (55 ± 4 ft-lb)	75 ± 5 Nm (55 ± 4 ft-lb)	45 ± 3 Nm (33 ± 4 ft-lb)
M22×1.5	90 ± 6 Nm (66 ± 4 ft-lb)	130 ± 8 Nm (96 ± 6 ft-lb)	60 ± 4 Nm(44 ± 3 ft-lb)
M27×2	120 ± 8 Nm (89 ± 6 ft-lb)	185 ± 12 Nm (136 ± 9 ft-lb)	100 ± 7 Nm (74 ± 5 ft-lb)
M30×2	140 ± 8 Nm (103 ± 6 ft-lb)	245 ± 15 Nm (181 ± 11 ft-lb)	135 ± 8 Nm (100 ± 6 ft-lb)
M33×2	180 ± 10 Nm (133 ± 7 ft-lb)	320 ± 20 Nm (236 ± 15 ft-lb)	160 ± 10 Nm(118 ± 7 ft-lb)
M42×2	240 ± 15 Nm (177 ± 11 ft-lb)	450 ± 25 Nm (332 ± 18 ft-lb)	210 ± 13 Nm (155 ± 10 ft-lb)
M48×2	280 ± 20 Nm (207 ± 15 ft-lb)	540 ± 30 Nm (398 ± 22 ft-lb)	260 ± 15 Nm (192 ± 11 ft-lb)
S (HEAVY-DUTY)			
M12×1.5	33 ± 2 Nm (24 ± 2 ft-lb)	43 ± 3 Nm (32 ± 2 ft-lb)	35 ± 2 Nm (26 ± 2 ft-lb)
M14×1.5	42 ± 3 Nm (31 ± 2 ft-lb)	50 ± 4 Nm (37 ± 3 ft-lb)	45 ± 3 Nm (33 ± 2 ft-lb)
M16×1.5	55 ± 4 Nm (41 ± 3 ft-lb)	75 ± 5 Nm (55 ± 4 ft-lb)	55 ± 4 Nm (41 ± 3 ft-lb)
M18×1.5	75 ± 5 Nm (55 ± 4 ft-lb)	95 ± 6 Nm (70 ± 4 ft-lb)	70 ± 5 Nm (52 ± 4 ft-lb)
M22×1.5	90 ± 6 Nm (66 ± 4 ft-lb)	140 ± 8 Nm(103 ± 6 ft-lb)	100 ± 10 Nm (74 ± 7 ft-lb)
M27×2	120 ± 8 Nm (89 ± 6 ft-lb)	185 ± 12 Nm (136 ± 9 ft-lb)	160 ± 10 Nm (118 ± 7 ft-lb)
M30×2	140 ± 8 Nm (103 ± 6 ft-lb)	245 ± 15 Nm (181 ± 11 ft-lb)	210 ± 13 Nm (155 ± 10 ft-lb)
M33×2	180 ± 10 Nm (133 ± 7 ft-lb)	320 ± 20 Nm (236 ± 15 ft-lb)	260 ± 15 Nm (192 ± 11 ft-lb)
M42×2	240 ± 15 Nm (177 ± 11 ft-lb)	450 ± 25 Nm (332 ± 18 ft-lb)	330 ± 20 Nm (243 ± 15 ft-lb)
M48×2	280 ± 20 Nm (207 ± 15 ft-lb)	540 ± 30 Nm (398 ± 22 ft-lb)	420 ± 25 Nm (310 ± 18 ft-lb)

Hydraulic fittings with inch thread (British Standard Pipe [BSP]) must be torqued to the following specifications.

Table 2-5 Hydraulic Fitting Torque – British Standard Pipe (BSP)

THREAD SIZE	INSTALLED INTO ALUMINUM	INSTALLED INTO STEEL	
	ED, O-RING + CIRCLIP	ED, O-RING + CIRCLIP	O-RING
L (LIGHT-DUTY)			
G1/8A	20 ± 1 Nm (15 ± 1 ft-lb)	20 ± 1 Nm (15 ± 1 ft-lb)	-
G1/4A	35 ± 2 Nm (26 ± 2 ft-lb)	40 ± 2 Nm (30 ± 2 ft-lb)	-
G3/8A	50 ± 3 Nm (37 ± 2 ft-lb)	75 ± 5 Nm (55 ± 2 ft-lb)	-
G1/2A	75 ± 5 Nm (55 ± 2 ft-lb)	95 ± 6 Nm (70 ± 4 ft-lb)	-
G3/4A	120 ± 8 Nm (89 ± 6 ft-lb)	185 ± 12 Nm (136 ± 9 ft-lb)	-
G1A	180 ± 10 Nm (133 ± 7 ft-lb)	320 ± 20 Nm (236 ± 15 ft-lb)	-
G1-1/4A	240 ± 15 Nm (177 ± 11 ft-lb)	450 ± 25 Nm (332 ± 18 ft-lb)	-

THREAD SIZE	INSTALLED INTO ALUMINUM	INSTALLED INTO STEEL	
	ED, O-RING + CIRCLIP	ED, O-RING + CIRCLIP	O-RING
G1-1/2A	280 ± 20 Nm (207 ± 15 ft-lb)	540 ± 30 Nm (398 ± 22 ft-lb)	-
S (HEAVY-DUTY)			
G1/4A	40 ± 3 Nm (30 ± 2 ft-lb)	43 ± 3 Nm (32 ± 2 ft-lb)	-
G3/8A	55 ± 3 Nm (41 ± 2 ft-lb)	85 ± 5 Nm (63 ± 4 ft-lb)	-
G1/2A	80 ± 5 Nm (59 ± 4 ft-lb)	120 ± 8 Nm (89 ± 6 ft-lb)	-
G3/4A	120 ± 8 Nm (89 ± 6 ft-lb)	185 ± 12 Nm (136 ± 9 ft-lb)	-
G1A	180 ± 10 Nm (133 ± 7 ft-lb)	320 ± 20 Nm (236 ± 15 ft-lb)	-
G1-1/4A	240 ± 15 Nm (177 ± 11 ft-lb)	450 ± 25 Nm (332 ± 18 ft-lb)	-
G1-1/2A	280 ± 20 Nm (207 ± 15 ft-lb)	540 ± 30 Nm (398 ± 22 ft-lb)	-

Hydraulic fittings with Unified Thread Standard (UNC/UNF) must be torqued to the following specifications.

Table 2-6 Hydraulic Fitting Torque – Unified Thread Standard (UNC/UNF)

THREAD SIZE	INSTALLED INTO ALUMINUM	INSTALLED INTO STEEL
	O-RING	O-RING
L (LIGHT-DUTY)		
7/16-20	21 ± 2 Nm (15 ± 2 ft-lb)	21 ± 2 Nm (15 ± 2 ft-lb)
9/16-18	34 ± 2 Nm (25 ± 2 ft-lb)	35 ± 2 Nm (26 ± 2 ft-lb)
11/16-12	40 ± 3 Nm (30 ± 2 ft-lb)	50 ± 4 Nm (37 ± 3 ft-lb)
3/4-16	50 ± 3 Nm (37 ± 2 ft-lb)	65 ± 4 Nm (48 ± 3 ft-lb)
7/8-14	75 ± 5 Nm (55 ± 4 ft-lb)	110 ± 8 Nm (81 ± 6 ft-lb)
1-1/16-12	110 ± 8 Nm (81 ± 6 ft-lb)	140 ± 10 Nm (103 ± 7 ft-lb)
1-5/16-12	160 ± 10 Nm (118 ± 7 ft-lb)	210 ± 15 Nm (155 ± 11 ft-lb)
S (HEAVY-DUTY)		
7/16-20	21 ± 2 Nm (15 ± 2 ft-lb)	23 ± 2 Nm (17 ± 2 ft-lb)
9/16-18	34 ± 2 Nm (25 ± 2 ft-lb)	40 ± 3 Nm (30 ± 2 ft-lb)
11/16-12	40 ± 3 Nm (30 ± 2 ft-lb)	65 ± 4 Nm (48 ± 3 ft-lb)
3/4-16	50 ± 3 Nm (37 ± 2 ft-lb)	80 ± 6 Nm (59 ± 4 ft-lb)
7/8-14	75 ± 5 Nm (55 ± 4 ft-lb)	125 ± 10 Nm (92 ± 7 ft-lb)
1-1/16-12	110 ± 8 Nm (81 ± 6 ft-lb)	185 ± 15 Nm (136 ± 11 ft-lb)
1-5/16-12	160 ± 10 Nm (118 ± 7 ft-lb)	280 ± 20 Nm (207 ± 15 ft-lb)

HYDRAULIC HOSE AND FITTING TORQUE PROCEDURE

The hydraulic hose and fitting must be torqued to the following requirements when they are installed.

1. Replace the O-ring if damaged. The O-ring cannot be reused if the fitting or hose end has been tightened beyond finger tight.
2. Lubricate the O-ring before installation.
3. Properly seat the O-ring.
4. Position the tube and nut squarely on the fitting. Then tighten the nut as required.
5. Tighten the nut or fitting to the torque specified in the appropriate table.
6. Operate all machine functions and inspect the hose, fittings and related components to confirm there are no leaks.

FASTENER TORQUE SPECIFICATIONS

Unless special torque requirements are stated in this manual or other instructions, torque metric bolts to the values listed in the table below.

Table 2-7 Fastener Torque Specifications – Metric

NOMINAL DIAMETER (MM)	PITCH (MM)	CLASS 8.8	CLASS 10.9	CLASS 12.9
5	0.8	7 Nm (5 ft-lb)	9 Nm (7 ft-lb)	10 Nm (7 ft-lb)
6	1	12 Nm (9 ft-lb)	15 Nm (11 ft-lb)	18 Nm (13 ft-lb)
8	1.25	30 Nm (22 ft-lb)	35 Nm (26 ft-lb)	42 Nm (31 ft-lb)
	1	30 Nm (22 ft-lb)	37 Nm (27 ft-lb)	45 Nm (33 ft-lb)
10	1.5	55 Nm (41 ft-lb)	75 Nm (55 ft-lb)	85 Nm (63 ft-lb)
	1.25	56 Nm (41 ft-lb)	77 Nm (57 ft-lb)	87 Nm (64 ft-lb)
	1	60 Nm (44 ft-lb)	80 Nm (59 ft-lb)	92 Nm (68 ft-lb)
12	1.75	95 Nm (70 ft-lb)	125 Nm (92 ft-lb)	150 Nm (111 ft-lb)
	1.5	100 Nm (74 ft-lb)	130 Nm (96 ft-lb)	155 Nm (114 ft-lb)
	1.25	105 Nm (77 ft-lb)	135 Nm (100 ft-lb)	160 Nm (118 ft-lb)
14	2	150 Nm (110 ft-lb)	200 Nm (148 ft-lb)	230 Nm (170 ft-lb)
	1.5	165 Nm (122 ft-lb)	210 Nm (155 ft-lb)	250 Nm (184 ft-lb)
16	2	230 Nm (170 ft-lb)	300 Nm (221 ft-lb)	360 Nm (266 ft-lb)
	1.5	250 Nm (184 ft-lb)	320 Nm (236 ft-lb)	380 Nm (280 ft-lb)
18	2.5	320 Nm (236 ft-lb)	420 Nm (310 ft-lb)	500 Nm (369 ft-lb)
	1.5	360 Nm (266 ft-lb)	470 Nm (345 ft-lb)	550 Nm (406 ft-lb)
20	2.5	450 Nm (332 ft-lb)	600 Nm (443 ft-lb)	700 Nm (516 ft-lb)
	1.5	500 Nm (369 ft-lb)	650 Nm (479 ft-lb)	770 Nm (568 ft-lb)
22	2.5	600 Nm (443 ft-lb)	800 Nm (590 ft-lb)	980 Nm (723 ft-lb)
	2	650 Nm (479 ft-lb)	850 Nm (627 ft-lb)	1050 Nm (774 ft-lb)

NOMINAL DIAMETER (MM)	PITCH (MM)	CLASS 8.8	CLASS 10.9	CLASS 12.9
24	3	750 Nm (553 ft-lb)	1050 Nm (774 ft-lb)	1250 Nm (923 ft-lb)
	2	800 Nm (590 ft-lb)	1100 Nm (811 ft-lb)	1300 Nm (959 ft-lb)
27	3	1150 Nm (848 ft-lb)	1500 Nm (1106 ft-lb)	1800 Nm (1327 ft-lb)
30	3.5	1500 Nm (1106 ft-lb)	2000 Nm (1475 ft-lb)	2400 Nm (1770 ft-lb)

Unless special torque requirements are listed in this manual or other instructions, torque Unified Thread Standard bolts (label: UNC) to the values listed in the table below.

Table 2-8 Bolt Torque Specifications Unified – Thread Standard (UNC)

NOMINAL DIAMETER (IN)	OPPOSITE NUT SIZE (S)	CLASS 5	CLASS 8
1/4-20	7/16"	10 Nm (7 ft-lb)	14 Nm (10 ft-lb)
5/16-18	1/2"	21 Nm (15 ft-lb)	29 Nm (21 ft-lb)
3/8-16	9/16"	37 Nm (27 ft-lb)	51 Nm (38 ft-lb)
7/16-14	5/8"	60 Nm (44 ft-lb)	82 Nm (60 ft-lb)
1/2-13	3/4"	90 Nm (66 ft-lb)	130 Nm (96 ft-lb)
9/16-12	13/16"	130 Nm (96 ft-lb)	180 Nm (133 ft-lb)
5/8-11	15/16"	178 Nm (131 ft-lb)	250 Nm (184 ft-lb)
3/4-10	1-1/8"	315 Nm (232 ft-lb)	445 Nm (328 ft-lb)
7/8-9	-	509 Nm (375 ft-lb)	715 Nm (527 ft-lb)

Unless special torque requirements are listed in this manual or other instructions, torque Unified Thread Standard bolts (label: UNF) to the values listed in the table below.

Table 2-9 Bolt Torque Specifications – Thread Standard (UNF)

NOMINAL DIAMETER (IN)	OPPOSITE NUT SIZE (S)	CLASS 5	CLASS 8
1/4-28	7/16"	11.5 Nm (8 ft-lb)	16 Nm (11 ft-lb)
5/16-24	1/2"	23 Nm (17 ft-lb)	32 Nm (24 ft-lb)
3/8-24	9/16"	41 Nm (30 ft-lb)	58 Nm (43 ft-lb)
7/16-20	5/8"	65 Nm (48 ft-lb)	92 Nm (68 ft-lb)
1/2-20	3/4"	100 Nm (74 ft-lb)	145 Nm (107 ft-lb)
9/16-18	13/16"	145 Nm (107 ft-lb)	200 Nm (148 ft-lb)
5/8-18	15/16"	200 Nm (148 ft-lb)	280 Nm (207 ft-lb)
3/4-16	1-1/8"	350 Nm (258 ft-lb)	495 Nm (365 ft-lb)
7/8-14	-	560 Nm (413 ft-lb)	780 Nm (575 ft-lb)

3 SYSTEM DESCRIPTIONS

POWER SOURCE

Machines are powered by two 12V batteries in series or a 24V lithium battery to drive a 24V DC motor, which in turn drives a gear pump to provide power to the system.

HYDRAULIC SYSTEM

The hydraulic system of the machine can be divided into two parts: one part is used for steering function and the other part for platform lifting function.

When the machine is activated, the hydraulic pump sends pressure oil to the function manifold which is equipped with directional valves for performing different actions. To protect relevant components and avoid pressure overload, the function manifold is provided with a relief valve.

ELECTRICAL SYSTEM

In the electrical system, machines are powered by two 12V batteries in series or a 24V lithium battery to drive the drive motor and the motor on the power unit to enable such functions as drive, steer and lift. The battery is charged from an external power supply. The machine is also equipped with a circuit breaker to protect the control system.

MACHINE CONTROL SYSTEM

The functions of the machine are controlled with two controllers in this system. A controller is located on the right door of the machine and controls the platform up/down functions. The other controller is located on the platform and controls lift and drive functions. The controller exchanges data through a high-speed data bus.

SAFETY MEASURES

A series of sensors and limit switches provides signals to the controllers.

Level sensor measures the angle of X axis and Y axis of the chassis. For more information, see [B-11 Inspect the Tilt Protection Function, page 5-16](#).

Pothole guard switch is used for verifying whether the pothole guard fully extends. For more information, see [B-12 Inspect Pothole Guards, page 5-17](#).

Up limit switch restricts the lifting height of platform. For more information, see [C-3 Inspect Up Limit Switch, page 5-18](#).

Down limit switch serves for staged lowering and speed control. For more information, see [C-4 Inspect Staged Lowering, page 5-19](#) and [B-10 Test Drive Speed, page 5-15](#).

Weighing system (synergy between pressure sensor and angle sensor) restricts the allowable load applied on the platform. For more information, see [C-2 Inspect Platform Weighing System\(optional\), page 5-18](#).

This Page Intentionally Left Blank

4 SERVICE AND GUIDELINES

MACHINE PREPARATION, INSPECTION AND MAINTENANCE

GENERAL

This section provides safety and necessary information for the machine operators. For maximum service life and safe operation, ensure that all necessary inspections and maintenance have been completed before placing the machine into service.

Machine positions

Stowed position :

The machine comes in stowed position when fully retracted.

Non-operating position :

The machine remains in non-operating position when the down limit switch does not disengage.

Operating/raised position :

The machine comes in operating/raised position when the platform is raised until the down limit switch disengages.

Note : The platform height(from ground to platform floor) is 2±0.2m(6ft 7in±8in) when the down limit switch disengages.

PREPARATION, INSPECTION AND MAINTENANCE

It is important to establish and conform to a comprehensive inspection and preventive maintenance program. This manual outlines the scheduled machine inspections and maintenance recommended by Hunan Sinoboom Intelligent Co., Ltd., Consult your national, regional or local regulations for aerial work platforms. The frequency of inspections and maintenance must be increased as environment, severity and frequency of usage requires.

QUALIFIED SINOBOOM EQUIPMENT MECHANIC

Qualified Sinoboom equipment mechanic is a person recognized by Sinoboom as one who, by possession of a recognized degree, certificate, training, has successfully demonstrated the ability and proficiency to service, repair and maintain the subject Sinoboom product model.

PRE-OPERATION INSPECTION

Prior to daily use or work shift of operators, the user or operator should perform a pre-operation inspection. Refer to the *Operation Manual* for the complete procedure for the pre-operation inspection. The *Operation Manual* must be entirely read and understood before performing the pre-operation inspection.

PRE-DELIVERY INSPECTION AND FREQUENT INSPECTION

The pre-delivery inspection shall be performed by qualified Sinoboom equipment mechanic. The pre-delivery inspection and the frequent inspection are performed in the same manner, but at different times. The pre-delivery inspection shall be performed before each sale, lease or rental delivery. The frequent inspection shall be accomplished for each machine in service for 3 months or 150 hours (whichever comes first); out of service for a period of more than 3 months; or when purchased used. The frequency of this inspection must be increased as environment, severity and frequency of usage requires.

Reference the *Prepare the Work Record before Delivery* and *Repair & Inspection Report* for items requiring inspection. Reference the *Inspection Procedures* in appropriate areas of this manual to perform the inspection and maintenance procedures.

ANNUAL MACHINE INSPECTION

The annual machine inspection must be performed on an annual basis, no later than 13 months from the date of the prior annual machine inspection. Hunan Sinoboom Intelligent Equipment Co.,Ltd. recommends this task be performed by a factory-trained service technician, a person recognized by Sinoboom as one who, by possession of a recognized degree, certificate,

training, has successfully demonstrated the ability and proficiency to service, repair and maintain the subject Sinoboom product model.

Reference the *Repair & Inspection Report* for items requiring inspection. Reference the *Inspection Procedures* in appropriate areas of this manual to perform the inspection and maintenance procedures.

For the purpose of receiving the safety-related bulletins, it is important that Hunan Sinoboom Intelligent Equipment Co., Ltd. has updated ownership information for each machine. When performing each annual machine inspection, notify Hunan Sinoboom Intelligent Equipment Co., Ltd. of the current machine ownership information.

PREVENTIVE MAINTENANCE

The preventive maintenance must be performed by a qualified Sinoboom equipment mechanic.

Reference the *Repair & Inspection Report* and *Maintenance Schedule* in this manual for the inspection items and intervals. Reference the *Inspection Procedures* in appropriate areas of this manual to perform the inspection and maintenance procedures.

Table 4-1

Type	Frequency	Primary Responsibility	Service Qualification	Reference
Pre-operation Inspection	Prior to use each day; or at each operator change.	User or operator	User or operator	Operation Manual
Pre-delivery Inspection	Prior to each sale, lease or rental delivery.	Owner, dealer or user	Qualified Sinoboom mechanic	Maintenance Manual, Pre-delivery Preparation Form, and Maintenance Inspection Report
Frequent Inspection	In service for 3 months or 150 hours, whichever comes first; or out of service for a period of more than 3 months; or purchased used.	Owner, dealer or user	Qualified Sinoboom mechanic	Maintenance Manual and Maintenance Inspection Report
Annual Machine Inspection	Annually, no later than 13 months from the date of the prior annual inspection.	Owner, dealer or user	Factory-trained service technician	Maintenance Manual, Pre-delivery Preparation Form, and Maintenance Inspection Report
Preventive Maintenance	At intervals as specified in the Maintenance Manual.	Owner, dealer or user	Qualified Sinoboom mechanic	Maintenance Manual, Maintenance Inspection Report, and Maintenance Schedule

STORAGE

Please observe the following recommendations to ensure the best performance of cylinders and avoid corrosion due to an extended period of storage (indoor/outdoor):

- The machine should be stored in stowed position with all tires adjusted to keep aligned.
- Fully raise and lower the scissor and steer left and right the wheels twice a week to lubricate the cylinders.

MAINTENANCE AND SERVICING PRECAUTIONS

GENERAL

This section assists you in the use and application of the maintenance and servicing procedures contained in this manual.

SAFETY AND WORKMANSHIP

Before servicing the machine, take the following preventive measures:

1. Cut off the power source to disable the machine and set up a sign in a readily visible place.
2. Place all controls in OFF position to prevent unintended activation of the controls.
3. Lower the platform to the lowest position if possible, or at least ensure it won't fall off.
4. Before releasing or removing any hydraulic component, dissipate the hydraulic pressure in the hydraulic circuit.

If the machine is not serviced in the state as above for the sake of the particular nature of the maintenance task, it should at least observe the safety rules regarding the maintenance and repair of the machine contained in this manual and the Operation Manual.

Your safety, and that of others, is the first consideration when engaging in the maintenance of equipment. Never attempt to move heavy parts without the aid of a mechanical device. Do not allow heavy objects to rest in an unstable position. When raising a portion of the equipment, ensure that adequate support is provided.

CLEANLINESS

1. The most important single item in preserving the service life of a machine is to keep dirt and foreign materials out of the vital components. Precautions have been taken to safeguard against this. Shields, covers, seals and filters are provided to keep air, fuel and oil supplies clean; however, these items must be maintained on a scheduled basis to function properly.
2. When air, fuel or oil lines are disconnected, clean the adjacent areas as well as the openings and fittings. As soon as a component or line is disconnected, cap or cover all openings to prevent entry of foreign matter.
3. Clean and inspect all parts during servicing and maintenance, and assure that all passages and openings are unobstructed. Cover all parts to keep them clean. Be sure all parts are clean before they are installed. New parts should remain in their containers until they are ready to be used.

COMPONENT REMOVAL AND INSTALLATION

1. Establish as per this manual a safe and reasonable program appropriate to the on-site conditions for installation of the machine.
2. The personnel engaging in disassembly and installation of this machine should be competent in the task and understand how to use the personal protection equipment in a correct manner.
3. The qualified personnel should not install the machine unless a thorough inspection of the ground for installation, the hidden foundation as well as the anchored parts is made or sufficiently evidenced to comply with the manufacturer's requirements.
4. The wind speed at the installation location should not be more than 8.3m/s.
5. Check the on-site conditions like power supply, foundation, track, etc., and install only when all are eligible.
6. All parts should be checked before installation to verify they are in good condition.
7. The high-strength bolts should be tightened as required in this manual.
8. The requirements for the reception of the on-site installed machine are as follows:
 - Conduct the required inspection and function test to confirm the machine is properly installed for the purpose of the particular application and all safety devices operate smoothly.
 - The static and dynamic load tests of the machine suggest a compliance with the relevant standard.

- The qualified personnel should sign on the handover document to evidence the integrity of the machine. All inspection/test results should be documented (including the inspector name, title, organization and date).
9. The disassembly of the machine should also follow the same safety requirements for the installation of the machine.
 10. If mechanical assistance is required for the disassembly of the machine, please choose the suitable lifting points, lifting tools, and lifting equipment according to this manual and the onsite conditions. The lifting equipment that allows adjustment is preferred. All lifting tools (chains, sling, etc.) should be parallel to each other and should better remain vertical to the top of the component being lifted.
 11. Should it be necessary to remove a component on an angle, keep in mind that the capacity of an eyebolt or similar bracket lessens, as the angle between the supporting structure and the component becomes less than 90 degrees.
 12. If a part resists removal, check to see whether all nuts, bolts, cables, brackets, wiring, etc, have been removed and that no adjacent parts are interfacing.

COMPONENT DISASSEMBLY AND ASSEMBLY

When disassembling or reassembling a component, complete the procedural steps in sequence. Do not partially disassemble or assemble one part, then start on another. Always recheck your work to assure that nothing has been overlooked. Do not make any adjustments, other than those recommended, without obtaining proper approval.

SCRAP OF STRUCTURAL PARTS

- When some major component fails to fulfill the safety requirements due to corrosion, wear, etc., it should be refitted or reinforced, otherwise it should be scrapped.
- When the stressed structure suffers a permanent deformation and a repair is impossible, it should be scrapped.
- When the major stressed structure loses stability at large, it should never get repaired and must be scrapped.
- When a crack is present on a structure or a weld, it can be properly reinforced according to the stress and crack conditions, and continued use is only allowed when it meets the original design requirements, otherwise it should be scrapped.

PRESSURE-FIT PARTS

When assembling pressure-fit part, use a molybdenum disulfide base compound or equivalent to lubricate the mating surface.

BEARINGS

1. When a bearing is removed, cover it to keep out dirt and abrasives. Clean bearings in nonflammable cleaning solvent and allow to drip dry. Compressed air can be used but do not spin the bearing.
2. Discard bearings if the races and balls (or rollers) are pitted, scored, or burned.
3. If bearing is found to be serviceable, apply a light coat of oil and wrap it in clean (waxed) paper. Do not unwrap reusable or new bearings until they are ready to install.
4. Lubricate new or used serviceable bearings before installation. When pressing a bearing into a retainer or bore, apply pressure to the outer race. If the bearing is to be installed on a shaft, apply pressure to the inner race.

GASKETS

Check that holes in gaskets align with openings in the mating parts. If it becomes necessary to hand-fabricate a gasket, use gasket material or stock of equivalent material and thickness. Be sure to cut holes in the right location, as blank gaskets can cause serious system damage.

BOLT USAGE AND TORQUE APPLICATION

NOTICE

Self-locking fasteners, such as nylon insert and thread deforming locknuts, are not intended to be reinstalled after removal.

1. Always use new replacement hardware when installing locking fasteners. Use bolts of proper length. A bolt which is too long will bottom before the head is tight against its related part. If a bolt is too short, there will not be enough thread area to engage and hold the part properly. When replacing parts, use only those having the same specifications of the original, or one which is equivalent.
2. Unless specific torque requirements are given within the text, standard torque values should be used on heat-treated bolts, studs, and steel nuts, in

accordance with recommended shop practices.
(See [Fastener Torque Specifications, page 2-7](#))

HYDRAULIC LINES AND ELECTRICAL WIRING

Clearly mark or tag hydraulic lines and electrical wiring, as well as as their receptacles, when disconnecting or removing them from the unit. This will assure that they are correctly reinstalled.

HYDRAULIC SYSTEM

1. The primary enemy of a hydraulic system is contamination. Contaminants enter the system by various means, e.g., using inadequate hydraulic oil, allowing moisture, grease, filings, sealing components, sand, etc., to enter when performing maintenance.
2. Keep the system clean. If evidence of metal or rubber particles are found in the hydraulic system, drain and flush the entire system.
3. Disassemble or reassemble parts on clean work surface. Clean all metal parts with non-flammable cleaning solvent. Lubricate components, as required, to aid assembly.

LUBRICATION

Service applicable components with the amount, type, and grade of lubricant recommended in this manual, at the specified intervals. When recommended lubricants are not available, consult your local supplier for an equivalent that meets or exceeds the specifications listed.

BATTERY

Clean battery, using a non-metallic brush and a solution of baking soda and water. Rinse with clean water. After cleaning, thoroughly dry battery and coat terminals with an anti-corrosion compound.

PINS AND COMPOSITE BEARING

1. Pinned joints should be disassembled and inspected if the following occurs :
 - Excessive sloppiness in joints.
 - Noise originating from the joint during operation.

2. The composite bearing should be replaced if the following occurs :
 - Frayed or separated fibers on the liner surface.
 - Cracked or damaged liner backing.
 - Bearing that have moved or spun in their housing.
 - Debris embedded in liner surface.
3. Pins should be replaced if any of the following is observed (pin should be properly cleaned prior to inspection) :
 - Detectable wear in the bearing area.
 - Flaking, peeling, scoring, or scratches on the pin surface.
 - Rusting of the pin in the bearing area.
4. Reassembly of pins and composite bearing:
 - Housing should be blown out to remove all dirt and debris. Bearings and bearing housings must be free of all contamination.
 - Bearing/pins should be cleaned with a solvent to remove all grease and oil. The composite bearing is a dry joint and needs no lubricating.
 - Pins should be inspected to ensure it is free of burrs, nicks, and scratches which would damage the bearing during installation and operation.

NOTICE

The oxidization exceeding a certain period will increase the resistance of the connector and eventually lead to electrical failure.

2. Silicone grease should be applied to each electrical cord that is exposed at the outside of the connector to prevent short circuit. Besides, the joint between the male and female connectors should also be applied with silicone grease. Other joints that may allow entry of water into the connectors, like the area around the anti-pull buckle, should be properly sealed as well.

NOTICE

Since the electrical conductivity of cleaning solvent is superior to that of water, it is mostly likely that this will occur when using pressure cleaning method to clean the machine.

3. Silicone grease should be applied to each contact of the connectors for battery case and charger.

NOTICE

The setting type sealant can be used to avoid short circuit and keep the connections tidy, but it will make the future removal of pins more difficult.

APPLICATION OF INSULATING SILICONE GREASE TO ELECTRICAL CONNECTIONS

Insulating silicone grease should be applied to all electrical connections for the purpose of :

- Avoiding oxidization of the mechanical joints between the male pins and female pins.
- Avoiding electrical failure due to low conductivity between the pins in humid environment.

The following procedure should be observed to apply the insulating silicone grease to the electrical connections. The procedure applies to all plugged connections outside of the power distribution box. The silicone grease is not suitable for the connectors with enclosed outer surface.

1. Prior to the machine assembling, apply silicone grease around the male pins and female pins inside the connectors to prevent oxidization. An injector may be used for the convenience of operation.

5 MAINTENANCE

This section provides detailed procedures for regular maintenance inspections. For further information about maintenance, please see *Maintenance Manual*.

 **WARNING**

UNSAFE OPERATION HAZARD



Failure to follow the proper maintenance may result in death, serious injury or damage to the machine.

Follow these general rules:

- Preventive maintenance procedure should be established by the user according to the manufacturer's recommendations, machine operational environment and intensity of use, which should include both the regular inspection and the annual inspection.
- Professionally trained, qualified personnel must conduct routine maintenance inspections on this machine.
- Daily routine maintenance inspections must occur during normal operation of the machine. Maintenance inspectors must carry out inspection and maintenance according to the repair & inspection report and must complete the repair & inspection report.
- Regular maintenance inspections must occur by operators and at quarterly, biannual and annual intervals by qualified, trained personnel. Qualified, trained personnel must check and maintain the machine according to the repair & inspection report and must complete the repair & inspection report.
- Immediately remove a damaged or malfunctioning machine, mark it and stop using it.
- Repair any damaged or malfunctioning machine before operating it.
- Keep all machine inspection records for at least 10 years or until the machine is no longer in use or as required by machine owner/company/custodian.
- The inspection and maintenance intervals depend on the manufacturer's recommendations, and should also be appropriate to the operational conditions and environment.
- Conduct a quarterly inspection on machines that have been out of service for a period lasting longer than three months.

- While maintaining the machine, replace any parts on the machine using the same parts or the same parts of the original machine.
- Unless otherwise specified, perform all maintenance procedures according to the following terms and conditions:
 - Park the machine on flat, level, firm ground.
 - Keep the machine in the stowed position.
 - Ensure the key switch of the ground controller is in the OFF position and remove the key to prevent unauthorized use of the machine.
 - Place the red emergency stop button on the platform control box and ground controller in the OFF position to avoid accidental start-up of the operating system.
 - Disconnect main power switch.
 - Disconnect all DC power from the machine.
 - Lock all wheels to prevent movement of the machine.
 - Before releasing or removing the hydraulic components, release the hydraulic oil pressure in the hydraulic pipeline.

CONDUCTING A PRE-DELIVERY INSPECTION

When the machine owner/company changes, in addition to conducting a pre-delivery inspection, the corresponding inspection shall be carried out according to the maintenance schedule requirement and repair & inspection report. When conducting a pre-delivery inspection, comply with the following requirements:

1. It is the responsibility of the machine owner/company to perform a pre-delivery inspection.
2. Follow this procedure each time before delivery. Performing a pre-delivery inspection could reveal potential problems with the machine before you begin putting the machine into service.
3. Never use a damaged or malfunctioning machine. Tag the machine and do not use it.
4. Only professionally trained, qualified personnel may repair the machine and must follow the procedures as stated in *operation manual* and *maintenance manual*.

- 5. A competent operator must conduct daily maintenance on this machine as stated in *operation manual* and *maintenance manual*.

Before delivering the machine, complete the following record using these instructions:

- 1. Prepare the machine before delivery, which includes performing a pre-delivery inspection,

following maintenance procedures and performing functional inspections.

- 2. Use the following table to note the results. After each section is complete, mark the appropriate box.
- 3. Record the inspection results. If any inspection results are "NO", the machine must be stopped and re-inspected after repair is completed and marked in the box marked "inspection".

Table 5-1

PREPARE THE WORK RECORD BEFORE DELIVERY			
Model			
Serial No.			
Inspection Item	YES/Machine is in Good Condition	NO/Machine Has Damage or Malfunction	REPAIRED/Machine Has Been Repaired
Pre-operational Inspection			
Maintenance Procedure			
Functional Inspection			
Machine Buyer/ Renter			
Inspector Signature			
Inspector Title			
Inspector Company			

FOLLOWING A MAINTENANCE SCHEDULE

Regular maintenance inspections must occur daily, quarterly, biannually (every 6 months) and annually, and must be performed by the personnel qualified in the maintenance and service of the machine models involved. Use the table to help you adhere to a routine maintenance schedule.

Table 5-2

INSPECTION INTERVAL	INSPECTION PROCEDURES
Every day or every 8 hours	A
Every quarter or every 250 hours	A+B
Every half a year or every 500 hours	A+B+C
Every year or every 1000 hours	A+B+C+D

COMPLETING A REPAIR & INSPECTION REPORT

- 1. Divide the Repair & Inspection Report into four sections (A, B, C and D) according to the time requirements of the maintenance schedule and the maintenance procedure requirements.
- 2. The Repair & Inspection Report shall include the inspection table of each regular inspection.
- 3. Duplicate the Repair & Inspection Report for each inspection. Store the completed tables for 10 years or until the machine is no longer in use or as required by machine owner/company/custodian.
- 4. Use the following table to note the results. After each section is complete, mark the appropriate box.
- 5. Record the inspection results. If any inspection results are "NO", the machine must be stopped and re-inspected after repair is completed and marked in the box marked "inspection". Select the appropriate inspection procedure based on the inspection type.

Table 5-3

REPAIR & INSPECTION REPORT				
Model				
Serial No.				
Checklist A Procedures				
Items	YES/Machine is in Good Condition	NO/Machine Has Damage or Malfunction	REPAIRED/ Machine Has Been Repaired	Problem Description
A-1 Inspect All Manuals				
A-2 Inspect All Decals				
A-3 Inspect Damaged, Loose or Lost Parts				
A-4 Inspect Hydraulic Oil Level				
A-5 Inspect Hydraulic Oil Leakage				
A-6 Functional Tests				
A-7 Inspect the Battery Level				
A-8 Perform Maintenance After 30 Days				
Checklist B Procedures				
Items	YES/Machine is in Good Condition	NO/Machine Has Damage or Malfunction	REPAIRED/ Machine Has Been Repaired	Problem Description
B-1 Inspect Electric Wires				
B-2 Inspect Rim ,Tire and Fasteners				
B-3 Inspect Battery				
B-4 Inspect Hydraulic Oil				
B-5 Inspect Hydraulic Tank Air Filter				
B-6 Inspect Manul Brake Release				
B-7 Inspect Emergency Lowering				
B-8 Inspect Braking Device				
B-9 Test Lift/Lower Speed				
B-10 Test Drive Speed				
B-11 Inspect Tilt Protection				

REPAIR & INSPECTION REPORT				
B-12 Inspect Pothole Guards				
Checklist C Procedures				
Items	YES/Machine is in Good Condition	NO/Machine Has Damage or Malfunction	REPAIRED/ Machine Has Been Repaired	Problem Description
C-1 Replace Hydraulic Oil Tank Air Filter				
C-2 Inspect Platform Weighing System				
C-3 Insepct Lift Limit Switch				
C-4 Inspect Staged Lowering				
Checklist D Procedures				
Items	YES/Machine is in Good Condition	NO/Machine Has Damage or Malfunction	REPAIRED/ Machine Has Been Repaired	Problem Description
D-1 Inspect Scissor Arm Installation Bearing				
D-2 Inspect Chassis Slider				
D-3 Replace Hydraulic Oil				
User				
Inspector Signature				
Inspector Date				
Inspector Title				
Inspector Company				

CHECKLIST A PROCEDURES

A-1 Inspect All Manuals

Storing the *Operation Manual* and the *Maintenance Manual* in the appropriate place is important for the safe operation of the machine. The manuals must be stored in the manual storage container on the platform. Illegible or damaged manuals cannot provide necessary safety and operation information for safe operation.

- Inspect and confirm that the manual storage container is placed on the appropriate position of the platform.
- Inspect and confirm that the *Operation Manual* and the *Maintenance Manual* are stored in the manual storage container on the platform.
- Inspect the pages of the manuals and confirm that they are legible and intact.
- Inspect the pages of the manuals and confirm that they are legible and intact.

NOTICE

If needing to replace the manuals, contact Hunan Sino-boom Intelligent Equipment Co., Ltd..

A-2 Inspect All Decals

Ensuring that all labels are in good condition is essential for safe operation of the machine. Decals warn operators of the dangers they may encounter during operations, and they provide users with operational and maintenance information. Illegible decals do not properly guide operators, which can lead to unsafe operations.

- Refer to the decal instructions in the *Operation Manual* and use the decals list and graphic to determine the correct placement of the decal.
- Check whether all decals are legible and damaged. Replace damaged and illegible decals before operating the machine.

NOTICE

If needing to replace the decals, contact Hunan Sino-boom Intelligent Equipment Co., Ltd..

A-3 Inspect Damaged, Loose or Lost Parts

Inspecting the condition of the machine daily is important for the safe and reliable operation of the machine. Never operate a machine with damaged, loose or lost parts. Replace damaged/lost parts and tighten loose parts before operating the machine.

Inspect the entire machine and check whether any parts are damaged, installed improperly or lost, including;

- Electrical components, wirings and cables
- Hydraulic power unit, oil tank, fittings, hoses, hydraulic cylinders and valve blocks
- Storage battery pack and its connections
- Drive motor
- Tires
- Power unit
- Limit switch and horn
- Alarms and indicator lamps (if equipped)
- Nuts, bolts and other fasteners
- Platform door
- Pothole guard device

- Pin shafts and fasteners for scissor arm
- Platform control joystick
- Fastening bolts on the sliding block of the platform

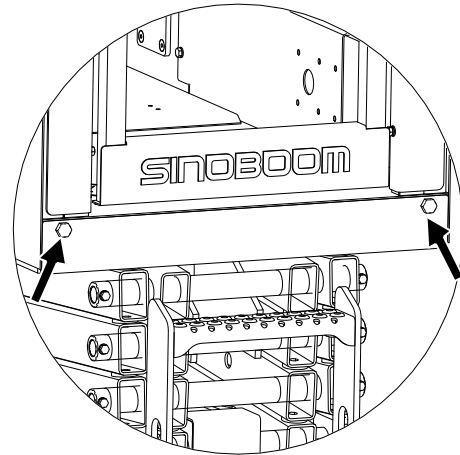

Figure 5-1

NOTICE

For any damaged, improperly installed or missing parts, correctly install new parts immediately. If the fasteners are loose, tighten them immediately.

A-4 Inspect Hydraulic Oil Level

Ensuring appropriate hydraulic oil is important for proper operation of the machine. Operating the machine with an improper hydraulic oil level can damage hydraulic components. Performing daily inspection of the hydraulic oil level will help you determine if a problem exists in the hydraulic system. Be sure to correct the problem before operating the machine.

Perform the following procedures with the platform retracted:

1. Open the door on the right side of the chassis.
2. Inspect the mark on the side of the hydraulic oil tank.
3. The hydraulic oil level should appear within "max" and "min" mark in the hydraulic oil tank.
4. Add hydraulic oil as needed. Never overfill the tank.

Table 5-4

CUSTOMER REQUIREMENTS	HYDRAULIC OIL MARK
Normal-temperature region 0°C to 40°C (32°F to 104°F)	L-HM46
Cold region -25°C to 25°C (-13°F to 77°F)	L-HV32
High-temperature region greater than 40°C (104°F)	L-HM68
Extremely cold region less than -30°C (-22°F)	Special programmes need to be identified.

NOTICE

Different hydraulic oils can be added according to customer requirements upon factory delivery, but cannot be mixed.

A-5 Inspect Hydraulic Oil Leakage

Preventing hydraulic oil leakage is important for safe and proper operation of the machine. Operating the machine with a hydraulic oil leak can lead to a hazardous situation, poor machine performance and damage to hydraulic components if the leak is not repaired.

Inspect for overflowing, dripping or residual marks on or around the following components:

- Hydraulic oil tank, filters, pipe fittings, oil pipe, power unit
- All hydraulic cylinders, pumps and motor
- All hydraulic valve blocks
- The area around the machine

A-6 Functional Tests

The functional test is essential to safe operation of the machine. If any function works improperly, it may cause an unsafe condition. Ensure all functions work smoothly and reliably without shock or unusual noise.

⚠ WARNING

UNSAFE OPERATION HAZARD

Be sure to follow the safety rules and instructions contained in this manual and the Operation Manual, otherwise it may cause serious injury or even death.

Before beginning a functional tests:

1. Select a test area that has a solid, flat, level surface.
2. Ensure the test area is free of obstacles.
3. Connect the battery to the machine if it is not already connected.
4. For the specific procedures for function test (steer, drive, brake, lift, etc.), please see **Pre-operation Function Test** section in the Operation Manual. Before performing the function test, be sure to read through and understand the safety rules in the Operation Manual.

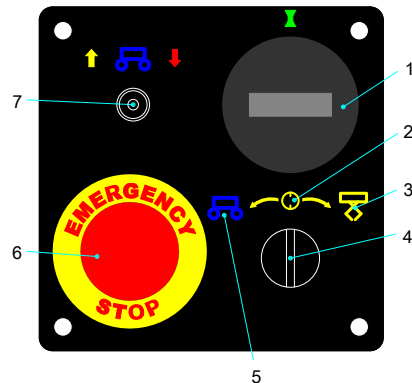

Figure 5-2 Ground controller(CANPLUS/DTC system-K300)

- | | |
|------------------------------|----------------------------|
| 1. Hour Meter | 5. Ground Control Position |
| 2. OFF Position | 6. Emergency Stop Button |
| 3. Platform Control Position | 7. Lifting/Lowering Switch |
| 4. Key Switch | |

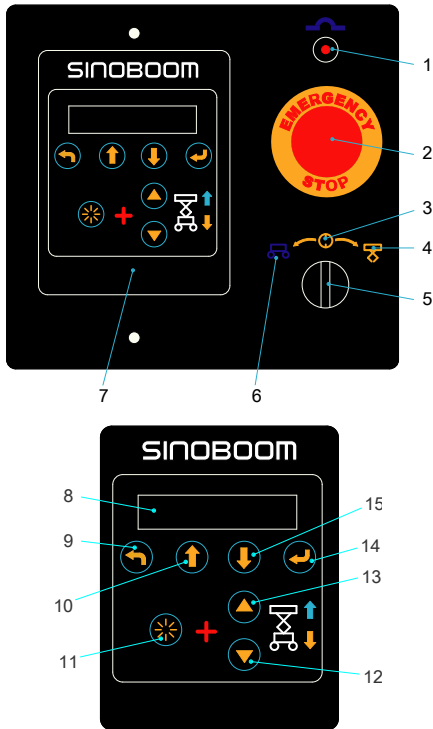

Figure 5-3 Ground controller (SINOBOOM/ DTC system-K500)

- | | |
|---|--------------------------|
| 1. Fuse | 9. Back key |
| 2. Emergency stop button | 10. Page up key |
| 3. Off position | 11. Enable switch |
| 4. Platform control | 12. Platform down switch |
| 5. Key switch (Ground/Platform control select switch) | 13. Platform up switch |
| 6. Ground control | 14. Enter key |
| 7. Controller | 15. Page down key |
| 8. Display screen | |

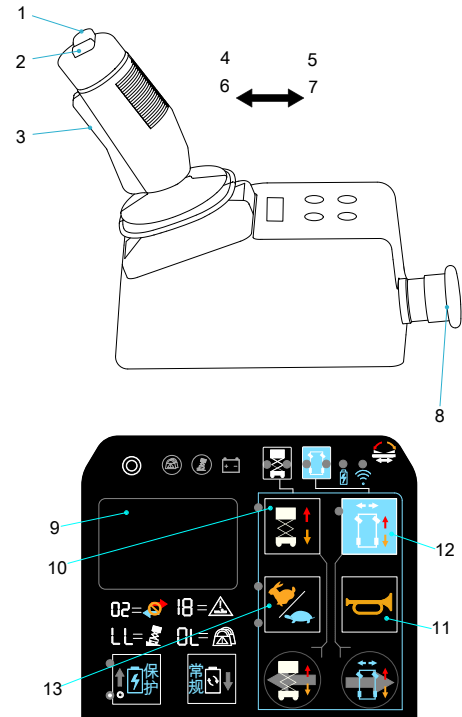

Figure 5-4 Platform controller (CANPLUS)

- | | |
|------------------|--|
| 1. Steer right | 8. Emergency stop button |
| 2. Steer left | 9. Display screen |
| 3. Enable switch | 10. Lift function enable switch |
| 4. Platform up | 11. Horn |
| 5. Platform down | 12. Drive/steer function enable switch |
| 6. Drive forward | 13. Drive high/low speed select switch |
| 7. Drive reverse | |

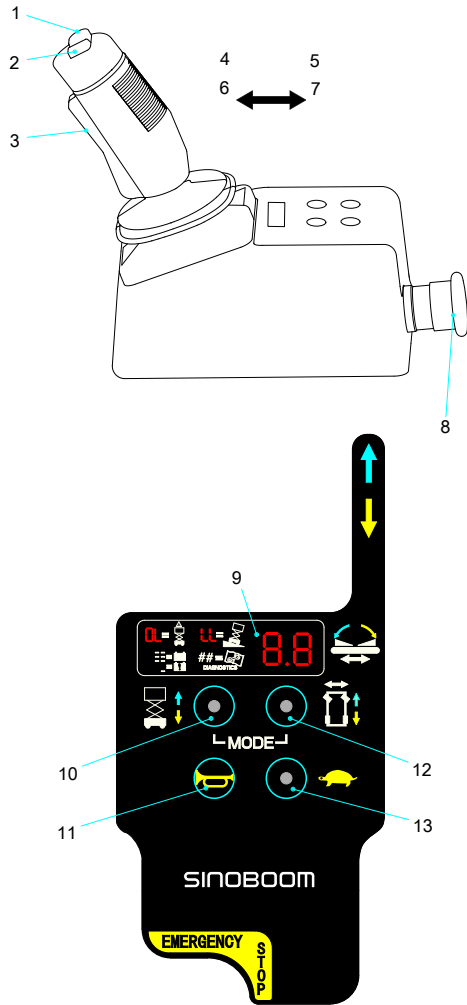

Figure 5-5 Platform controller (DTC system)

- | | |
|------------------|--|
| 1. Steer right | 8. Emergency stop button |
| 2. Steer left | 9. Display screen (to display battery level and fault codes) |
| 3. Enable switch | 10. Lift function enable switch |
| 4. Platform up | 11. Horn |
| 5. Platform down | 12. Drive/steer function enable switch |
| 6. Drive forward | 13. Drive high/low speed select switch |

7. Drive reverse

Note : Refer to the **Fault Diagnosis** section of Maintenance Manual for the fault codes displayed on the screen.

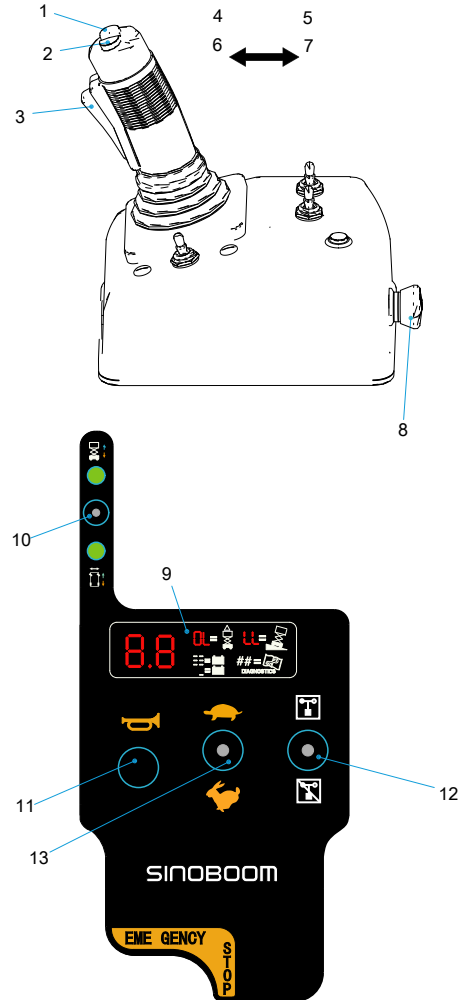

Figure 5-6 Platform controller (SINOBOOM)

- | | |
|------------------|--|
| 1. Steer right | 8. Emergency stop button |
| 2. Steer left | 9. Display screen (to display battery level and fault codes) |
| 3. Enable switch | 10. Lift, drive & steer function enable switch |
| 4. Platform up | 11. Horn |
| 5. Platform down | 12. Indoor/outdoor mode select switch |

6. Drive forward

13. Drive high/low speed select switch





7. Drive reverse

Note : Refer to the *Fault Diagnosis* section of Maintenance Manual for the fault codes displayed on the screen.

A-7 Inspect the Battery Level

The battery power level can be checked through the platform screen.

Table 5-5

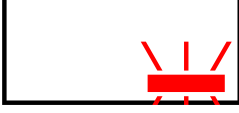
PLATFORM POWER DISPLAY	POWER RATIO	DESCRIPTION
	90-100%	The battery has been fully charged.
	70%	The battery is at 70% of its capacity.
	50%	The battery is at 50% of its capacity.
	30%	The battery is at 30% of its capacity.
	20%	The battery level is at 20%, which is low. The battery requires recharging.
	10%	The battery level is at 10%, which is very low. The machine will become slow. The battery requires recharging.

A-8 Perform Maintenance After 30 Days

Perform maintenance on a new machine after the machine is operated for 30 days or 40 hours. After performing the 30-day maintenance, continue performing maintenance as scheduled.

Perform the following procedures:

- B-2 Inspect Rim ,Tire and Fasteners

CHECKLIST B PROCEDURES

B-1 Inspect Electric Wires

The maintenance of electric wires is important for proper and safe operation of the machine. Serious injury and unsafe operation of the machine could occur if you allow the machine to continue to operate with damaged and corroded wires. Replace or repair damaged or corroded wires before operating the machine.

 **WARNING**

ELECTRICAL SHOCK HAZARD



Be sure to disconnect the battery from the machine and the charger from the AC outlet before inspecting electrical wires. Contacting live wire conductors could result in death or serious injury.

1. Inspect electrical wires for damage or corrosion in the following areas:
 - Battery harness
 - Charger harness
 - Scissor arm harness
 - Power unit harness
 - Ground controller junction box
 - Platform controller junction box

2. Inspect the flexile joints, and confirm that the joints are tight and the sensor lines are not damaged.

B-2 Inspect Rim, Tire and Fasteners

Good maintenance of rims and tires is important for the safe operation of the machine. The machine might tip over if the rim or the tire has problems. Repair any problems with the rims and tires before operating the machine.

The machine is equipped with solid tires that do not need to be inflated.

1. Inspect for cuts, cracks, puncture or abnormal wear patterns on all tires.
2. Inspect and verify that all rims are not damaged or deformed and that no welding cracks exist.
3. Remove the cotter pin, inspect it and confirm that the mounting nuts have been tightened with the correct torque.

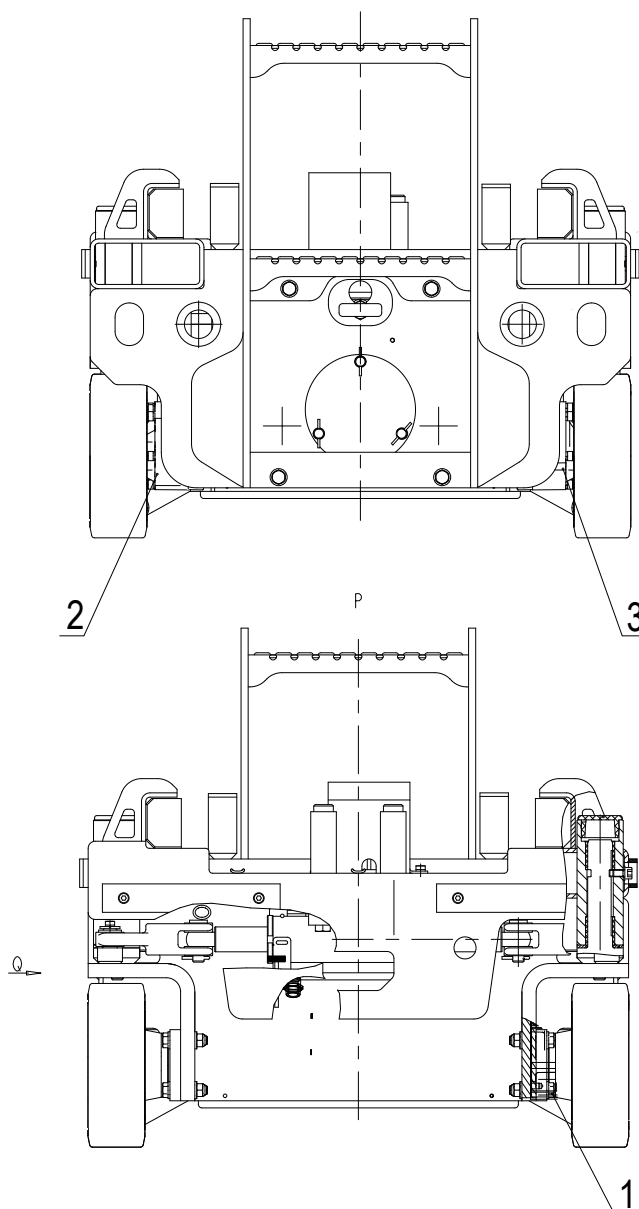

Figure 5-7

Table 5-6

No	Name	Torque Value/Nm(Ft-Lb)
1	Bolts (hub bearing seat mounting)	93 Nm(68.5 ft-lb)
2	Bolts (left drive reducer mounting)	60 Nm(44 ft-lb)
3	Bolts (right drive reducer mounting)	60 Nm(44 ft-lb)

- Replace the cotter pin and bend it to the locking position.

NOTICE



When inspecting the retaining nut, replace the split pin frequently. Never reuse the split pin.

B-3 Inspect Battery

The condition of the battery affects the performance of the machine. Improper levels of battery electrolyte or damaged cable and wiring may harm battery parts and may pose dangerous conditions.

⚠ WARNING

ELECTROCUTION HAZARD

- **Contact with live circuit may cause serious injury or death. Be sure to wear goggles, gloves and protective clothing.**
- **Remove all rings, watches and other jewelry.**

⚠ WARNING

BODILY INJURY HAZARD



Lead-acid batteries and lead-acid maintenance-free batteries contain acid. Avoid acid overflow or contact with acid in lead-acid batteries and lead-acid maintenance-free batteries.

If battery acid spills, use water mixed with bicarbonate (baking soda) to neutralize the acid.

Note : Before performing this procedure, fully charge the battery, and hold it still for 24 hours to equalize the battery cells.

1. Ensure the battery cells are wire reliably with the locking nuts torqued to the specifications as below:

Nut type	Torque
M8	9 ~ 11Nm (6.6 ~ 8.1ft-lb)
M10	18 ~ 23Nm (13.2 ~ 17ft-lb)

NOTICE

Improper connection may cause reduced performance, damaged terminals, fusions and even fires.

2. Ensure the battery negative and positive are correctly connected.
3. Ensure the battery connections are not corroded.

Note: Adding a terminal protector and anti-corrosion agent will prevent the terminals from corrosion.

The instructions below are applied only for batteries requiring maintenance :

4. Wear goggles, gloves and protective clothing.
5. Remove the ventilation cover.
6. Full add the liquid gravity meter and drain for twice or three times, then take a sample from the battery electrolyte.
7. Measure sequentially the gravity of all battery cells and note down the readings.
8. If the ambient temperature is above 27°C(80°F), add 0.004 to calibrate the gravity reading for every 5°C(40°F) higher; if the ambient temperature is below 27°C(80°F), reduce 0.004 to calibrate the gravity reading for every 5°C(40°F) lower;
 - Result 1 : if the gravity readings of all battery cells are 1.250 or higher, and the difference of the gravity readings is less than 0.050, proceed with the next step.
 - Result 2 : if the gravity readings of all battery cells are below 1.250, it indicates the battery is running low and needs charging. After charged, measure the gravity reading, if it meets the Result 1, proceed with the next step.
 - Result 3 : if the difference of the gravity readings is greater than 0.050, equalize the battery pack and hold it still for 6 hours before re-measurement of the gravity readings, if satisfying the Result 1, proceed with the next step.
9. Check the battery electrolyte level, add distilled water to the required level if needed
10. Install the ventilation cover to the battery.

Note : if the Result 1 cannot be met even after many attempts, the battery may have malfunctions.

B-4 Inspect Hydraulic Oil

Inspecting and replacing the hydraulic oil is important for the proper operation of the machine and the extension of service life. The machine may be unable to operate properly if the hydraulic oil becomes dirty, and the hydraulic parts may be damaged if using contaminated oil. Replace the hydraulic oil often, especially when the service environment is very dirty.

NOTE: Due to wear and tear on the mesh components, metal particles may appear in the hydraulic fluid or filter of the new machine.

WARNING

BURN HAZARD



Before maintaining the hydraulic system, allow the hydraulic fluid to cool to room temperature.

Replace the hydraulic oil if any of the following conditions exist.

- The hydraulic oil is milky white and cloudy.
- The hydraulic oil is blackened.
- Obtain a sample of the hydraulic oil and inspect it in sunlight. Rub the oil between two fingers to determine if it contains metal particles.
- The hydraulic oil has an abnormal smell.

See **D-3 Replace Hydraulic Oil, page 5-19** for replacement steps.

B-5 Inspect Hydraulic Oil Tank Air Filter

Good ventilation of the hydraulic oil tank cap is important for the proper operation of the hydraulic pump and its normal service life. The hydraulic pump would not suction smoothly if the air filter of the hydraulic oil tank is unqualified in cleanliness, and hydraulic components may be damaged after repeated use of a dirty or blocked air filter. Inspect the air filter of the hydraulic oil tank more frequently if the service environment is very tough.

NOTICE

This procedure must be performed when the drive motor/hydraulic motor is stopped.

1. Remove the oil filter of the hydraulic oil tank.
2. Inspect the vent hole.
3. The air must pass through the air filter smoothly.
4. If air does not pass through the air filter, follow the steps below to clean the air filter.
5. Clean the air filter with mild solvent, and then blow dry with compressed air. Repeat step 2.
6. Install the air filter on the oil tank.

B-6 Inspect Brake Manual Release Function

WARNING

UNSAFE OPERATION HAZARD



- Unless in case of emergency situations, machine malfunction, power loss or loading/unloading, it is strictly prohibited to tow or drag the machine.
- When towing/dragging the machine, there should be no person in the platform.
- Before towing/dragging the machine, ensure that the machine is in stowed position with the turntable securely locked and platform free of any tools or objects.
- Do not tow/drag the machine with the drive hub engaged.
- The machine must on a level surface or secured before releasing the brake.
- The towing/dragging of the machine must follow the local laws and traffic rules.

The machine needs towing/dragging in case of an emergency, machine malfunction or power loss. There are two methods to release the brake:

Method 1:

1. Chock the wheels from rolling.
2. Ensure the path of travel is clear of obstructions.
3. Locate the brake on the drive motor.

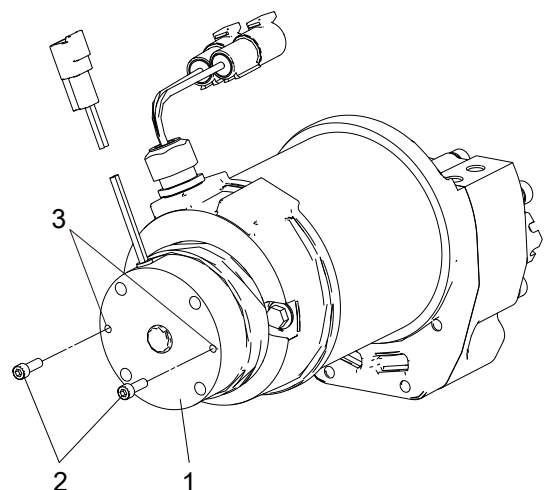

Figure 5-8 Drive motor

Table 5-7

NO.	NAME	DESCRIPTION
1	Brake	\
2	Special screw	M4×35-A2-70GB/T70.1
3	Disengage hole	\

4. Insert the special screw into the 2 disengage holes on the brake.
5. Tighten the special screw, the brake on the drive motor will disengage.
6. Repeat the above procedures onto the other drive motor. After the both brakes are disengaged, the machine allows moving by human power.
7. After the towing is completed, chock the wheels and remove the special screw from the disengage hole.
8. Restore the special screw to its original position.
9. Remove the chocks as needed.

Method 2:

1. Chock the wheels from rolling.
2. Ensure the path of travel is clear of obstructions.
3. Turn the key switch to the ground controls.
4. Pull out the emergency stop button on the platform controller to the ON position.
5. Pull out the emergency stop button on the ground controller to the ON position, and meanwhile hold the Enter key for 5s, the setting screen will be shown on the display.
6. Press the Page Down key until the display shows "- Machine Mode", then press the Enter button.
7. Press the Page Down key until the display shows "- Break Release", then hold the Enter key for 5s.
8. The horn should sound, while the buzzer should be sounding continuously, the brake is released successfully.
9. The machine allows moving by human power.
10. After the towing is completed, re-energize the machine, the brake can operate properly.
11. Remove the chokes as needed.

NOTICE

The allowable towing speed is 3km/h (1.9mph) .

B-7 Inspect Emergency Lowering Function

NOTICE

This test is performed when the platform is empty.

1. Push the emergency stop button on the ground controller and platform controller to the ON position.
2. Turn the key switch on the ground controller to the ground control position.
3. CANPLUS/DTC system-K300: Move the ground lifting/lowering switch up and raise the platform to the highest position.

SINOBOOM/DTC system-K500 : Simultaneously press and hold the enable switch and platform up switch on the ground controller to raise the platform to the highest position.

4. Pull out the emergency lowering handle located behind the chassis.

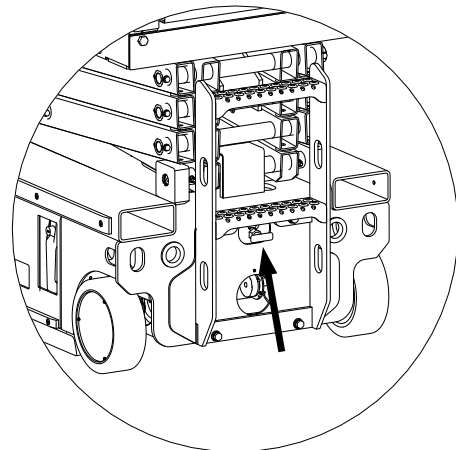

Figure 5-9

5. The platform shall descend to the lowest position.

B-8 Test Braking Device

Braking device must operate smoothly and be in good condition for safe and proper operation of the machine. Do not operate the machine if the brakes make a grinding sound or other abnormal noise. The machine is braked by the front wheel.

1. The machine only carries one person and is in the state of fully retracted.
2. Turn the key switch to the platform control position.
3. Operate the control handle to drive the machine on flat pavement at maximum speed. Then release the handle rapidly.



4. Measure the braking distance of the machine.
Result: The braking distance must be less than 0.5 m (20 in.).

NOTICE
<i>Park the machine on a slope with maximum gradient. The machine must not be able to slide.</i>

5. The machine is fully loaded and is in the state of lifted.
6. Operate the control handle to drive the machine on flat pavement at maximum speed. Then release the handle rapidly.
7. Measure the braking distance of the machine.
Result: The braking distance must be less than 0.05 m (2 in.).

B-9 Test Full Lift/Lower Time

Appropriate lifting or lowering speed is important for the safe operation of the machine. The lifting/lowering function must be able to respond to the actions of the operator rapidly and stably, without swinging, impact and abnormal noise.

 WARNING
UNSAFE OPERATION HAZARD
 <p>Park the machine on level and solid surface and operate from the ground controller to raise/lower the non-loaded platform.</p>

1. Using the ground controller, raised the machine from stowed to fully raised position.
2. Test the platform full lift time : 30 ~ 33s.
3. Using the ground controller, raised the machine from fully raised to stowed position.
4. Test the platform full lift time : 25 ~ 30s.

B-10 Test Drive Speed

Driving the machine at a reasonable speed is essential to safe machine operation. The drive function should respond quickly and smoothly under the control of the operator. The machine should drive within its entire speed range free of vibration, impact or abnormal noise.

1. Pull out the emergency stop buttons on the ground and platform controllers to the ON position.

2. Turn the key switch on the ground controller to the platform control position.

Low speed test :

3. —SINOBOOM system : move upwards the lift function enable switch on the platform controller, the indicator light of the switch should be on.
—DTC system/CANPLUS system : Press the lift function enable button on the platform controller, the button should illuminate.
4. Hold the enable switch on the control handle and deflect forward to activate the platform up function, and raise the platform to operating position.
5. —SINOBOOM system : move downwards the lift function enable switch on the platform controller, the indicator light of the switch should be on. Hold the enable switch on the control handle and slowly deflect forward to full drive position, the machine should drive at 0.8km/h (0.5mph) , or 123 ~ 150s for a travel distance of 30m (98ft 5in) .
—DTC system/CANPLUS system : Press the drive/steer function enable button, and hold the enable switch on the control handle and slowly deflect forward to full drive speed position, the machine should drive at 0.8km/h (0.5mph) , or 123 ~ 150s for a travel distance of 30m (98ft 5in) .

NOTICE
<i>If the machine takes less than 123s to travel 30m (98ft 5in), tag and remove the machine from service.</i>

Turtle speed test :

6. —SINOBOOM system : move upwards the lift function enable switch on the platform controller, the indicator light of the switch should be on. Hold the enable switch on the control handle and deflect forward to activate the platform down function, and lower the platform to non-operating position.
DTC system/CANPLUS system : Press the lift function enable button on the platform controller. Hold the enable switch on the control handle and deflect backward to activate the platform down function, and lower the platform to non-operating position.
7. —SINOBOOM system : move downwards the drive/steer function enable switch, the indicator light should be on. And then move upwards the drive high/low speed select switch, the low speed mode should be activated.



DTC system/CANPLUS system : press the drive/steer function enable switch, and then press the drive high/low speed select switch, the low speed indicator light should be on.

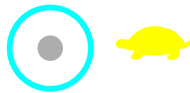

- 8. Hold the enable switch on the control handle and slowly deflect forward to full drive speed position, the machine should drive at 2km/h (1.24mph) , or 50 ~ 59s for a travel distance of 30m (98ft 5in) .

NOTICE
If the machine takes less than 50s to travel 30m (98ft 5in), tag and remove the machine from service.

High speed test :

- 9. —SINOBOOM system : move downwards again the drive high/low speed switch on the platform controller, the high speed mode should be activated.
—DTC system/CANPLUS system : press again the drive high/low speed select switch, the low speed indicator light should be off.
- 10. Hold the enable switch on the control handle and slowly deflect forward to full drive speed position, the machine should drive at 4km/h (2.5mph) , or 25 ~ 30s for a travel distance of 30m (98ft 5in) .

NOTICE
If the machine takes less than 25s to travel 30m (98ft 5in), tag and remove the machine from service.

B-11 Inspect the Tilt Protection Function

WARNING

UNSAFE OPERATION HAZARD



- Do not reach your hand or arm to the place where it may get crushed.
- Before the safety arm is properly in place, do not work under the platform or scissor arm.



NOTICE

Perform this step while you are standing on the ground using the platform controller. Do not stand on the platform while testing this function.

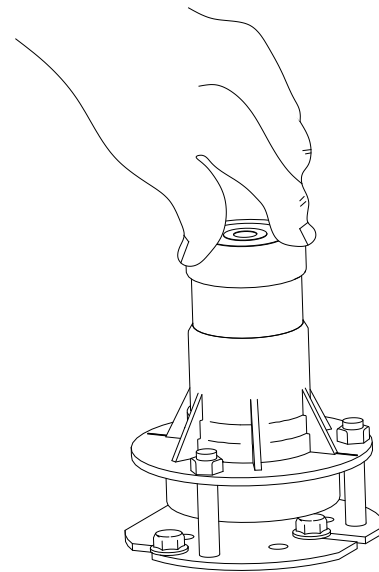

Figure 5-10

1. Raise the platform to the height which allows the safety arm to completely set up.
2. Set up the safety arm and lower the platform appropriately to ensure the safety arm supports effectively.
3. Flip the level switch to exceed 1.5 degrees in the left-to-right direction. Ensure the machine sounds an alarm.
4. Flip the level switch to exceed 3 degrees in the front-to-back direction. Ensure the machine sounds an alarm.

5. Lower the platform completely.
6. Place the two wooden boards under the two wheels on the left or right side of the machine, and then drive the machine onto the two boards. The wooden boards should measure(L × W × H): 100 mm × 50 mm × 19 mm (4 in. × 2 in. × 0.75 in.).
7. Change the machine’s walking function to a platform lifting function and then push the handle to raise the platform about 2 m (6.6 ft), the tilt alarm will sound, and the display screen will show “LL”, the machine cannot be operated to raise further or drive, but the lowering is allowed.
8. Completely lower the platform. Change the machine’s platform lifting function to a walking function. Drive the machine down and remove the wooden boards.
9. Place the two wooden boards under the two wheels on the front or back side of the machine, and then drive the machine onto the two boards. The wooden boards should measure(L × W × H): 100 mm × 50mm × 58 mm (4 in. × 2 in. × 2.3 in.).
10. Change the machine’s walking function to a platform lifting function and then push the handle to raise the platform about 2 m (6.6 ft), the tilt alarm will sound, and the display screen will show “LL”, the machine cannot be operated to raise further or drive, but the lowering is allowed.
11. Completely lower the platform. Change the machine’s platform lifting function to a driving function. Drive the machine down and remove the wooden boards.

B-12 Inspect Pothole Guards

1. Raise the platform until the press plate of scissor is off the carrier rod of the pothole guard.
2. The pothole guard plate should automatically extend.
3. Push hard on the left/right pothole guard plate. Ensure the pothole guard plate cannot be flipped upward.
4. Lower the platform. The pothole guard plate should automatically retract.
5. Place a wooden block under the pothole guard and raise the platform. The wooden block should measure(L × W × H): 100mm×50mm×50mm (4in×2in×2in) .
6. When the platform raises until the press plate of scissor comes off the carrier rod of the pothole guard, the buzzers at the ground and platform controls should sound, and the display should indicate “18”, the platform up and drive functions should be restricted, with only the platform down function operative.



7. Completely lower the platform and remove the wooden block.



CHECKLIST C PROCEDURES

C-1 Replace Hydraulic Oil Tank Air Filter

Good ventilation of the hydraulic oil tank cap is important for the proper operation of the hydraulic pump and its normal service life. The hydraulic pump would not suction smoothly if the air filter of the hydraulic oil tank is unqualified in cleanliness, and hydraulic components may be damaged after repeated use of a dirty or blocked air filter. Inspect the air filter of the hydraulic oil tank more frequently if the service environment is very tough.

NOTICE
<i>This procedure must be performed when the drive motor/hydraulic motor is stopped.</i>

 WARNING
BURN HAZARD
 <p>Allow the hydraulic oil to cool to room temperature before servicing the hydraulic system.</p>

 WARNING
HIGH-PRESSURE HAZARD
 <p>Slowly remove the hydraulic components to reduce hydraulic oil pressure. High hydraulic oil pressure could penetrate the skin. Seek medical attention immediately.</p>

1. Remove the air filter from the hydraulic tank.
2. Install and tighten the new air filter.
3. Clean all oil spills during the replacement process.
4. Start the machine and inspect the filter and hydraulic components to ensure no leakage exists.

C-2 Inspect Platform Weighing System (optional)

The weighing system is an option function, before testing ensure your machine is equipped with such function.

1. Position the machine on a flat, level and solid surface clear of obstacles, ensure each bearing and sliding groove is well lubricated.
2. Operating from the ground controls, raise the platform with no load upon for twice, ensure there is no obvious shaking or malfunction.

3. With the platform raised by approx. 1m, gradually add loads to the platform.
 - When the weight does not exceed 240kg (529lb), ensure that the platform is able to lift to the highest position.
 - When the platform load exceeds 288kg (635lb), the overload indicator lamp will illuminate, an alarm will sound, and all functions will be restricted from use. Once you remove the excess weight, the work platform will be able to move again.

NOTICE

When the hydraulic oil is at a low temperature, the viscosity will increase and have an obvious effect on the pressure testing. If the temperature at which the new machine works differs from that of the manufacturer by over 10°C (50°F), or the hydraulic oil temperature is less than 15°C(59°F), and the alarm sounds when the rated load is not reached(the ground or platform display shows OL), please re-calibrate the weight sensor.

NOTICE

Only qualified person trained by Sinoboom is allowed to calibrate the weighing system.

WEIGHT CALIBRATION (DTC SYSTEM)

Note : This section of weight calibration is applied only for DTC system, for the weight calibration of other control systems, please contact Sinoboom service personnel.

NOTICE

Only qualified person trained by Sinoboom is allowed to calibrate the weighing system.

No-load calibration

1. Ensure the platform is without any load.
2. Press and hold the Enter key on the ground controller for 5s, and turn the key switch to the ground control position.
3. The ground display will show “1.Set speed”, through the up/down key, select “3.Calibration”.
4. Press the enter key, the ground display will show “Execute No Load Calibration?”. Press and hold the enter key for 5s to start the auto calibration, or press the Esc key to give up the calibration and go back to the calibration window.
5. After the calibration has been done, the ground display will show the calibration results(“No Load Calibration Complete!”or “Angel Sensor Failure!”) .

Press the Esc key to go back to the calibration window.

Full-load calibration

1. Place a rated load to the platform.
2. Press and hold the Enter key on the ground controller for 5s, and turn the key switch to the ground control position.
3. The ground display will show “1.Set speed”, through the up/down key, select “3.Calibration”.
4. Press the enter key, the ground display will show “Execute No Load Calibration?”. Through the up/down key, select the “Execute Full Load Calibration?”, then press and hold the Enter key for 5s to start the auto full-load calibration, or press the Esc key to give up the calibration and go back to the calibration window.
5. After the calibration has been done, the ground display will show the calibration results(“Sensors have been changed!”or “Pressure Sensor Failure!” or “Angel Sensor Failure!”) . Press the Esc key to go back to the calibration window.

For the description of the keys of the ground controller , please refer to the *Ground Controller* section of Operation Manual or *Functional Test* section of Maintenance Manual.

C-3 Inspect Up Limit Switch

1. Park the machine on flat, level and firm ground.
2. Operate on the ground controller and raise the platform to the highest position.

3. Check the height of the platform (distance from ground to platform floor) : 3.8 ~ 3.9 m (12.5 ~ 12.8 ft) .

C-4 Inspect Staged Lowering

1. Park the machine on flat, level and firm ground.
2. Operate on the platform controller and raise the platform to the highest position.
3. Then Lower the machine with platform controller to a height of approximately 2±0.2m(6ft 7in±8in). The machine will stop lowering automatically.
4. Release the control handle and return it to the middle position. Reactivate the lowering function using the platform controller. After 5 seconds, the platform will continue to lower.

CHECKLIST D PROCEDURES

D-1 Inspect Scissor Arm Installation Bearing

Effectively maintaining the scissor arm installation bearing is important for proper operation of the machine. Repeated use of an old bearing may damage parts and cause unsafe operation.

NOTICE

Perform this procedure when the scissor arm has been fully retracted.

1. Measure the clearance between the shaft and the shaft sleeve with a feeler gauge.
2. Replace the shaft sleeve when the clearance is greater than 0.3 mm (0.011 in) or the service life is 10 years.

D-2 Inspect Chassis Slider

Properly maintaining the slider is important for safe operation of the machine. The chassis slider slides on the channel steel surface to form a friction pair. Use of an improper slider or repeated use of an old slider could damage parts and cause unsafe operation.

NOTICE

Perform this procedure when the scissor arm is in the fully retracted state.

1. Measure the distance from the bottom surface of every slider at the sliding end to the center of the installation shaft. (Reference size: 40 mm [1.57 in.]).
2. Result: Replace the slider when it shows wear measuring more than 3 mm [0.11 in.] (the measured distance L is less than 37 mm [1.46 in.]). See [Fig 5-10 , page 5-19](#)

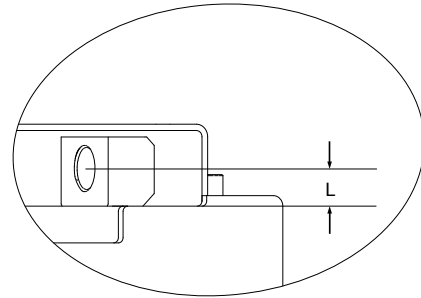

Figure 5-11

D-3 Replace Hydraulic Oil

Inspecting and replacing the hydraulic oil is important for the proper operation and service life of the machine. The machine may be unable to operate properly if the hydraulic oil and the filter screen become dirty, and the hydraulic parts may be damaged after repeated use of hydraulic oil with unqualified cleanliness. Replace the hydraulic oil when the service environment is very harsh. As required in the specifications, replace the hydraulic oil once a year.

WARNING

BURN HAZARD



Before maintaining the hydraulic system, cool the oil down to room temperature.

NOTICE

This procedure must be performed with the machine off. When removing the hoses and fittings, the O-ring must also be replaced.

⚠ WARNING

HIGH PRESSURE HAZARD



Slowly remove the hydraulic element to reduce the hydraulic oil pressure. The high-pressure hydraulic oil may penetrate the skin, if hurt, please go to a doctor immediately.

1. Open the right chassis door, and locate the hydraulic tank.
2. Remove the hydraulic power unit.
3. Remove the filler cap of the hydraulic tank, slowly turn the entire power unit to empty the hydraulic oil into a suitable container. For the capacity of hydraulic tank, see [Performance Parameters, page 2-1](#).

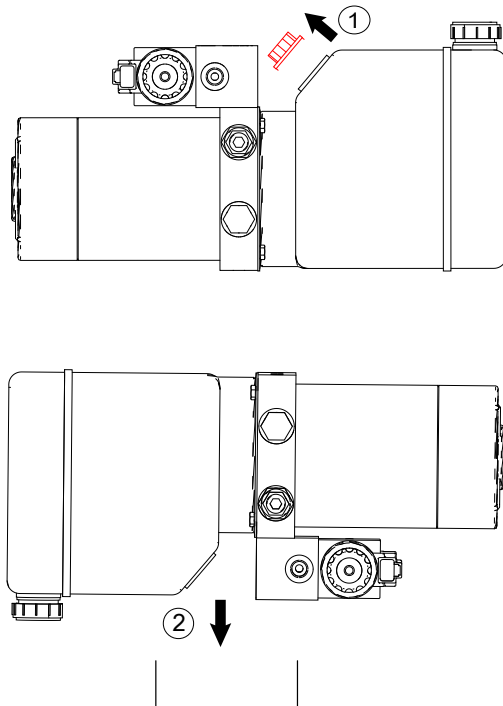

Figure 5-12

4. After the oil is fully emptied, remove the retaining screw of the hydraulic tank, and remove the hydraulic tank from the power unit assembly.

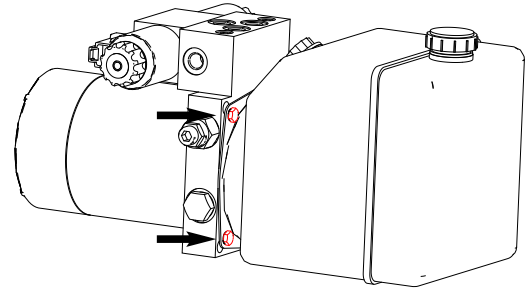

Figure 5-13

5. Wash the oil tank inside with mild solvent and allow the hydraulic oil tank to dry.
6. Install the hydraulic tank onto the power unit assembly.
7. Install the power unit assembly onto the inside of the right chassis door.
8. Add new hydraulic oil.

6 REPAIR

WARNING



Repair procedures must be performed by qualified, trained and competent personnel in a properly equipped workshop.

Replace or repair damaged components immediately. Do not operate the machine with known damaged components.

Be sure the machine is properly maintained before operating it.

Before starting the machine:

- Read, understand and follow all safety rules and instructions in this manual.
- Read all procedures and specifications completely.
- Unless otherwise specified, perform all maintenance procedures per the following:
 - Park the machine on flat, level and firm ground.
 - Be sure the platform is fully retracted.
 - Turn the key switch to the “OFF” position and remove the key.
 - Chock all wheels.

NOTICE

Perform this procedure when the scissor arm has been fully retracted.

1. Disconnect the external power supply. Turn the emergency stop button on the platform controller and ground controller to the OFF position.
2. Locate the cable connected to the bottom of the platform controller.
3. Tag and disconnect the cable from the bottom of the platform controller.
4. Remove the retaining screws from the platform controller and remove the platform controller.
5. Remove the star-shaped handle, and remove the bracket.
6. Move the platform controller and bracket away from the platform.

Removing the Platform

1. Remove the platform control box from the platform. Refer to [Platform Controller, page 6-1](#).
2. Strap the platform to a suitable lifting equipment.
3. Remove the bolt in the slider at the fixed end of the chute at the bottom of the platform.

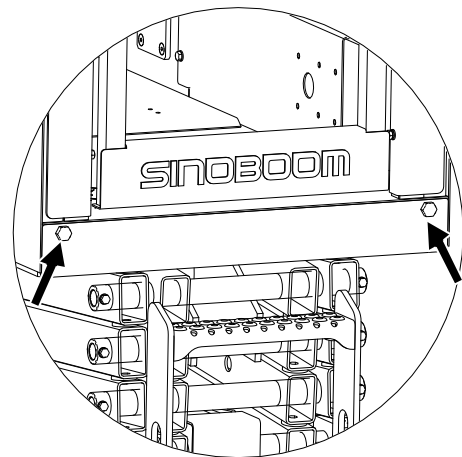

Figure 6-1

4. Lift and push the platform to move the sliding block to separate the platform.
5. Slowly lift the platform away.

PLATFORM COMPONENTS

Platform Controller

WARNING



ELECTRICAL SHOCK HAZARD

Be sure to disconnect the battery from the machine and the charger from the AC outlet before performing this procedure. Contact with live conductors could result in death or serious injury.

Removing the Extension Platform

1. Remove the platform. Refer to [Removing the Platform, page 6-1](#).
2. Loosen the bolts of all rails. Remove rails and put them aside.
3. Loosen the bolts and pin on the roller bracket of the extended platform.
4. Loosen the bolts and pin on the roller bracket of the fixed platform and remove the roller bracket.
5. Lift the extended platform from the front end and the rear end. Remove the extension platform.

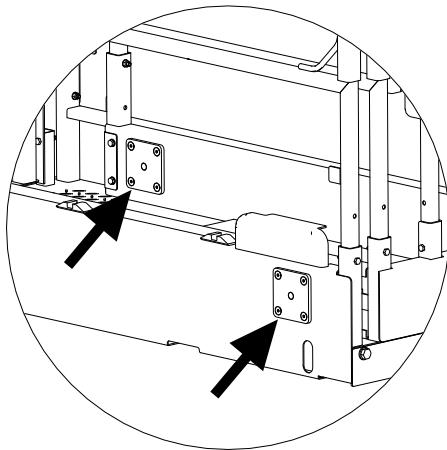

Figure 6-2

4. Remove the bolts of the fixed clevis pin.

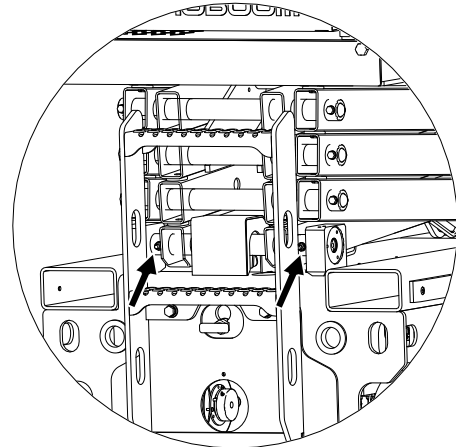

Figure 6-3

5. Pull out the clevis pin.

! WARNING	
CRUSH HAZARD	
	<p>Do not allow hands, other body parts and clothing to come in contact with moving machinery parts.</p>

6. Move the travelling crane parallel to move the slide block out of the slide chute.
7. Remove the scissor arm assembly.

SCISSOR COMPONENTS

Removing the Scissor Arm

NOTICE
<p><i>Perform this procedure when the scissor arm is fully retracted.</i></p>

1. Remove the platform and extension platform. Refer to [Removing the Platform, page 6-1](#) and [Removing the Extension Platform, page 6-2](#).
2. Disconnect the hydraulic system and electric system connecting the scissor arm with the chassis.

NOTICE
<p><i>While removing the rubber hose and connector, be sure to remove and mark the O-rings at the end of the rubber hose or hose.</i></p>

3. Connect the scissor arm with a traveling crane.

Lift Cylinder

! WARNING	
HIGH-PRESSURE HAZARD	
	<p>Slowly remove the hydraulic components to reduce hydraulic oil pressure. High hydraulic oil pressure could penetrate the skin. Seek medical attention immediately.</p>

1. Connect the scissor arm to the travelling crane. Lift the scissor arm until the safety arm can be set up.
2. Support the scissor arm with the safety arm.
3. Disconnect and plug the hoses and fittings on the hydraulic cylinder.

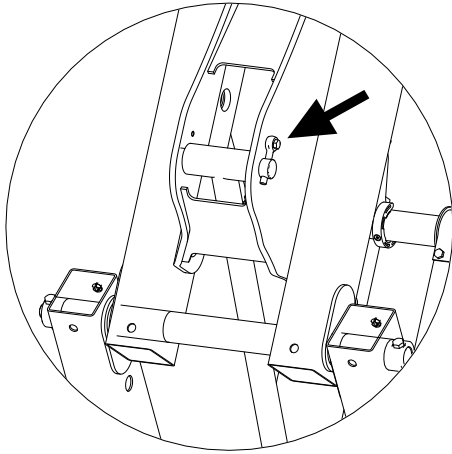

Figure 6-4

4. Remove the bolts retaining the guide sleeve of the cylinder piston rod.
5. Remove the clevis pins.

NOTICE

Use caution when removing the cylinder. Do not allow the cylinder to drop and become damaged.

6. Remove the nuts connecting the base of the oil cylinder and the scissor arm.
7. Remove the bolts.

WARNING

FLYING OBJECT HAZARD



Wear eye protection when striking the brass bar with a mallet.

8. Carefully drive out the clevis pin with a brass bar and mallet.
9. Carefully pull out the oil cylinder.

CHASSIS COMPONENTS

Tires and Rims

Replacing tires and rims

Hunan Sinoboom Intelligent Equipment Co., Ltd. recommends the replacement tires be of the same size, ply rating and brand as the original tires. For the part number of a specific machine model, please reference

the Part Manual. If the replacement tires are not as Hunan Sinoboom Intelligent Equipment Co., Ltd. recommends, the following requirements of tires should be met :

1. Ply rating/rated load and dimension equal or greater than original.
2. Tire tread contact width equal or greater than original.
3. Wheel diameter, width and offset dimensions equal to the original.
4. Approved for the application by the tire manufacturer (including intended purposes, maximum drive speed and maximum tire load, etc.).
5. Due to size variations between different tire brands, both tires on the same axle should be the same.

WARNING

UNSAFE OPERATION HAZARD



The tires and rims installed on each product model have been designed for stability requirements. Size changes such as rim width, center piece location, diameter, etc., without written factory recommendations, may result in an unsafe condition regarding stability.

Removal and installation

WARNING

UNSAFE OPERATION HAZARD



- Use the wheel nuts that suit the rim bolts. The wheel nuts must be installed and maintained at the proper torque to prevent loose wheels, broken studs and possible dangerous separation of wheels from the axle. Be sure to only use the nuts matched to the cone angle of the wheel.
- Tighten the lug nuts to the proper torque to prevent wheels from coming loose. Use a torque wrench to tighten the fasteners. If you do not have a torque wrench, tighten the fasteners with a socket wrench, then immediately have a service garage or dealer tighten the lug nuts to the proper torque. Over-tightening will result in breaking the studs or permanently deforming the mounting stud holes in the wheels.

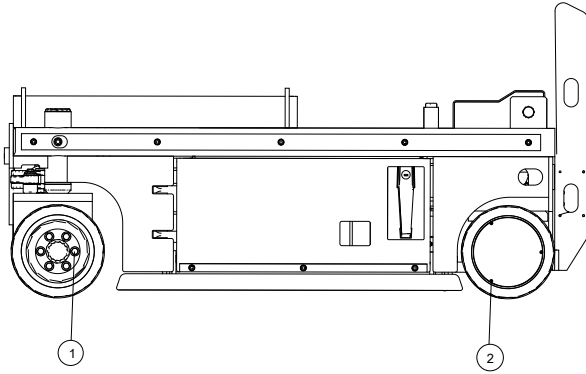

Figure 6-5

1. Place the machine on a firm level surface.
2. Place a jack of ample capacity under the chassis on the side to be removed, raise the jack to make the wheel off the ground.
3. Use a suitable device to support the wheel assembly.
4. Front wheels : remove the hex screws and washers at the wheel #1; Rear wheels : remove the hex screws and washers at the wheel #2.
5. Remove the wheel assembly and move away the supporting device.
6. Front wheels : align the mounting holes of the new wheel or the one to be used with those of the reducer, and apply threadlocker Loctite 272 to the wheel bolts and install in sequence. Rear wheels : align the mounting holes of the new wheel or the one to be used with the center axis of bearing housing, and then tighten the nut.

NOTICE

Wheel nuts should be torqued prior to first use of machine and after each wheel removal. Check torque every 3 months or 150 hours of operation.

Removing the Reducer & Drive Motor

The reducer & drive motor not only serves as a power drive but also helps in securing the rear wheels, therefore, before removing the reducer & drive motor, support the machine on a suitable structure or place a jack of ample capacity under the chassis.

NOTICE

Be sure to disconnect the battery charger and main power from the machine before removing the reducer & drive motor.

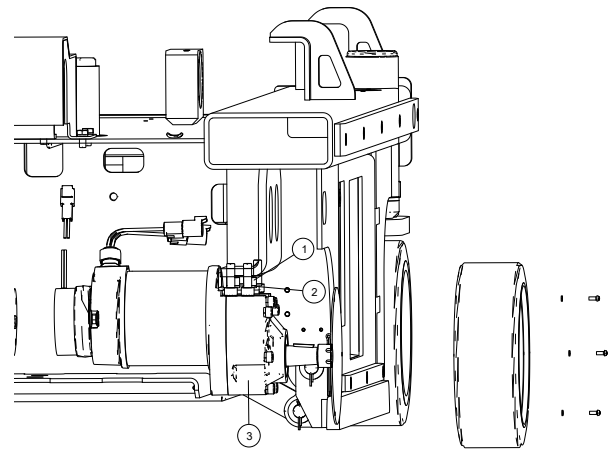

Figure 6-6

Removal of reducer and drive motor

1. Place the machine on a solid, level surface.
2. Place a jack of sufficient capacity under the side of chassis to be removed. Lift the jack to make the wheel off the ground.
3. Remove the wheel assembly, refer to [Tires and Rims, page 6-3](#).
4. Tag and disconnect the electric wiring to the reducer & drive motor.
5. Use a suitable lifting device to support the reducer & drive reducer.
6. Remove the bolt #1 and washer #2 securing the reducer & drive motor to the wheel support, and remove the reducer & drive motor #3.

Installation of reducer and drive motor

1. Align the mounting holes of reducer & drive motor with those of the wheel support.
2. Apply threadlocker Loctite 272 to the bolts, and install in turns.
3. Tighten the bolts with a torque wrench.
4. Connect the electric wiring.
5. Install the wheel assembly. Refer to [Tires and Rims, page 6-3](#).

Removing the Front Wheel Bracket

NOTICE

When installing the removed hose and fitting, it must be tightened according to the specified torque. See [Hydraulic Hose and Fitting Specifications, page 2-4](#).

Be sure to use an adequate lifting device with enough capacity to lift the chassis. Be sure to place the lifting device at a proper location on the frame.

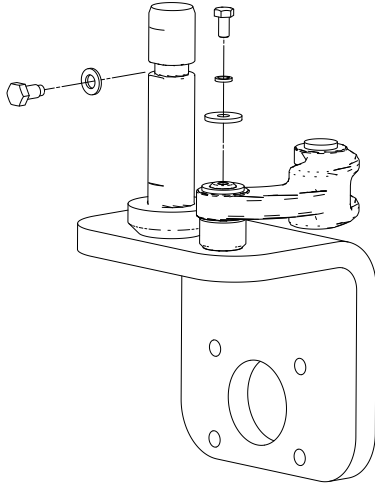

Figure 6-7

1. Remove the nuts and gaskets connected with the steering linkage of the front wheel.
2. Remove the fixing bolts from the front wheel bracket.
3. Remove the front wheel bracket.

Steer Cylinder

NOTICE

When installing the removed hose and fitting, it must be tightened according to the specified torque. See [Hydraulic Hose and Fitting Specifications, page 2-4](#).

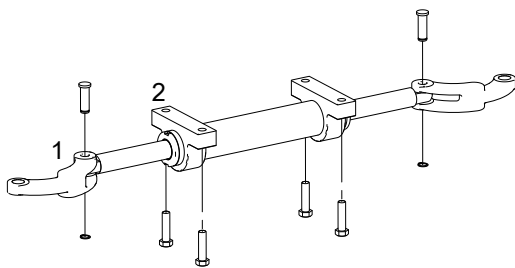

Figure 6-8

1. Disconnect and plug the hoses and fittings on the steering cylinder, and tag the machine.
2. Remove the cotter pin and clevis pin connecting the steering cylinder and steering linkage.
3. Remove the bolts connecting the steering cylinder to the chassis.
4. Remove the steering cylinder.

Battery

NOTICE

Be sure to disconnect the battery charger and main power from the machine before removing the battery.

1. Open the left door.
2. Label and disconnect the wires connected to the battery.
3. Use the appropriate lifting equipment to remove the battery.

Battery

NOTICE

Be sure to disconnect the battery charger and main power from the machine before removing the battery.

1. Open the left door.
2. Label and disconnect the wires connected to the battery.
3. Use the appropriate lifting equipment to remove the battery.

HYDRAULIC SYSTEM

Hydraulic Power Unit

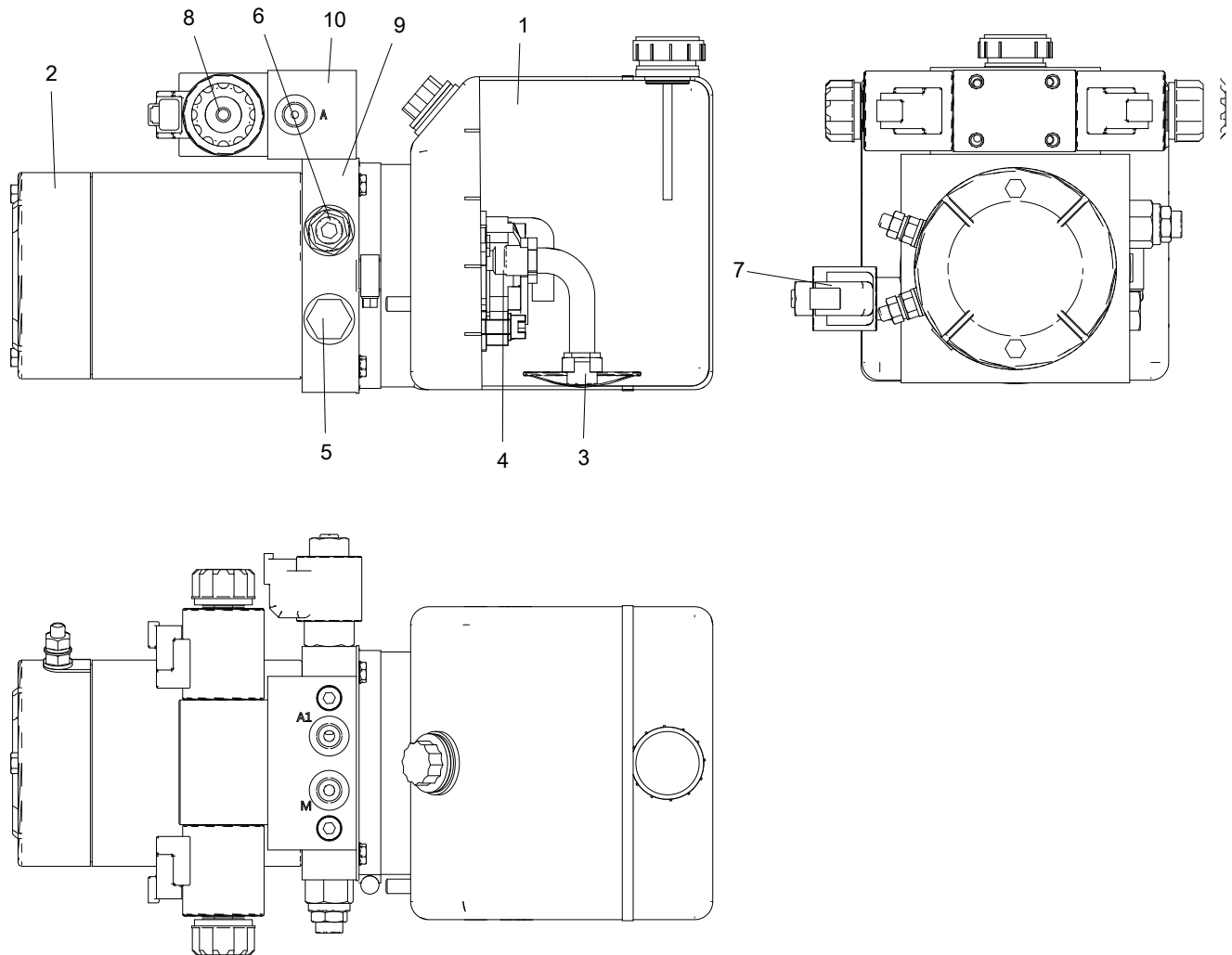

Figure 6-9

Table 6-1

1. Plastic oil tank	2. DC motor	3. Screen
4. Gear pump	5. Check valve	6. Direct-actin relief valve
7. 2-position 2-way solenoid valve	8. 3-position 4-way solenoid directional valve	9. Central manifold
10. Transition manifold		

Removal

WARNING

BURN HAZARD

Before maintaining the hydraulic system, allow the hydraulic fluid to cool down to room temperature. Slowly loosen the hydraulic hoses and fittings to release the pressure.

NOTICE

*When installing the hoses and fittings, be sure to torque to specifications as specified in **Hydraulic Hose and Fitting Specifications, page 2-4.***

1. Open the right chassis door and locate the hydraulic power unit.
2. Tag and disconnect the cables connected to the power unit.
3. Tag, sconnect and plug the hoses and fittings connected to the power unit.
4. Remove the retaining screws at the bottom of the power unit.
5. Remove the power unit.

Installation

Install in the reverse sequence as opposed to the removal procedure.

Lift Control Valve Assembly

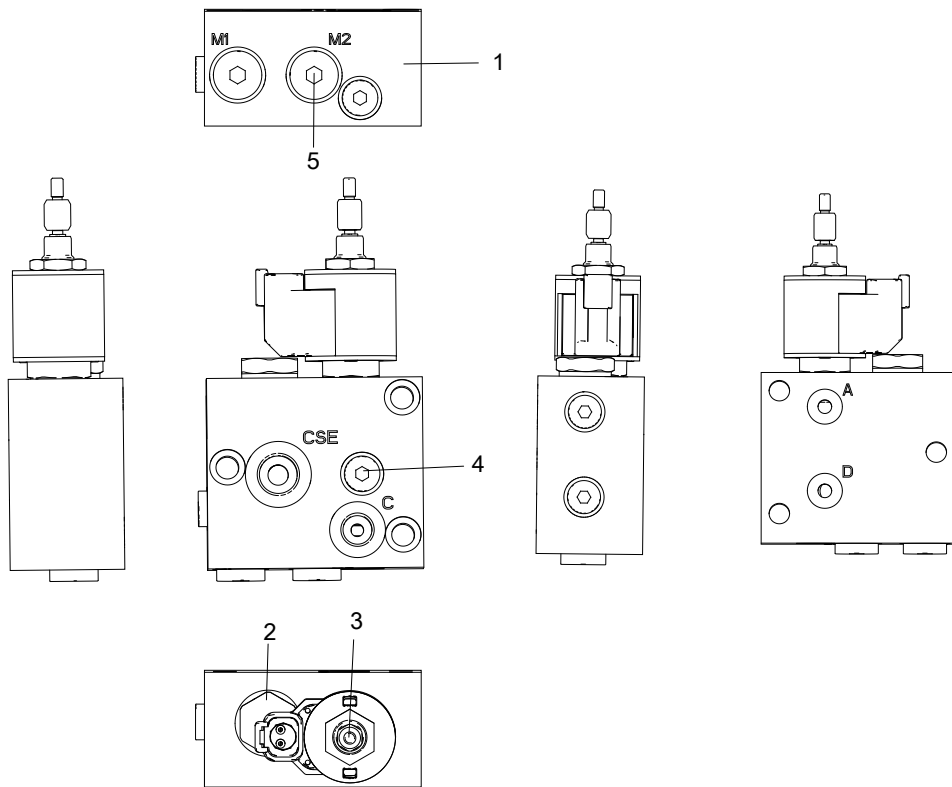

Figure 6-10 Lift control valve

Table 6-2

No.	Name	Function	Torque
1	Lift manifold	With channels inside to service as a carrier for elements such valve spool.	\
2	Check valve	To keep the fluid flowing in one direction	27Nm (20ft-lb)

No.	Name	Function	Torque
3	Solenoid valve	To control the on/off of the oil circuit	27Nm (20ft-lb)
4	Throttle screw	\	2Nm (1.5ft-lb)
5	Throttle screw	\	2Nm (1.5ft-lb)

Removing the lift control valve

WARNING

BURN AND HIGH PRESSURE HAZARD

Before servicing the hydraulic system, cool down the hydraulic oil to room temperature. Slowly loosen the hoses and fittings to release the pressure.

NOTICE

When re-installing the hoses & fittings, torque to specifications as listed in [Hydraulic Hose and Fitting Specifications, page 2-4](#).

1. Tag and disconnect the pressure sensor and cables to the lift control valve.
2. Tag, disconnect and plug the hoses and fittings to the lift control valve.
3. Remove the screws securing the lift control valve to cylinder.
4. Remove the lift control valve.

Regulating Platform Lift Relief Valve Pressure

NOTICE

Ensure the hydraulic oil level is at the FULL position of the hydraulic tank.

1. Place the maximum rated load on the platform and ensure it is placed properly. (For details, see [Performance Parameters, page 2-1](#).)
2. Turn the Ground/Platform select switch to Ground, and pull the emergency stop buttons on the ground controller and platform control box out to the "ON" position.

3. Hold the lift relief valve with a wrench and loosen the nut.
4. While turning the platform lifting switch, turn the inner hexagon socket clockwise until the platform rises to the highest position.
5. Lower the platform completely.
6. Add the weight 1.2 times of the rated load on the platform and properly place it.
7. Try to lift the platform, the platform cannot be lifted.
8. If the platform is still lifting, turn the inner hex of the lift relief valve counterclockwise till the platform cannot be lifted.
9. Install the nut
10. Remove the loads from the platform.
11. Raise the platform to full height, if there is an air suction of the pump or if the platform cannot be lifted to the highest position, add hydraulic oil to the tank until the pump properly operates.

NOTICE

Do not continue operation if the pump suctions air.

Adjusting the Emergency Lowering Handle

NOTICE

The platform must be empty to perform this test.

Adjust the emergency drop handle as follows:

1. Raise the platform to a certain height to allow the safety arm to fully set up.
2. Properly lower the platform to ensure the safety arm supports effectively.

WARNING

PINCH-POINT HAZARD

Be sure to keep hands and other body parts away from the scissor arm while lowering the platform.

3. Pull out the emergency lowering handle located behind the chassis.

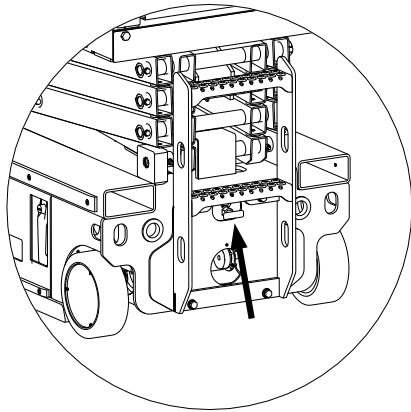

Figure 6-11

4. Measure the distance between the end of the handle and the mounting nuts.
5. If the measurement distance is less than or equal to 3mm (0.12in), go to step 8. If the measurement distance is greater than 3mm (0.12in), go to step 6.
6. Adjust the mounting nut so that the distance between the end of the handle and the mounting nut is no more than 3mm (0.12in).
7. Disengage the safety arm.
8. Pull the release lever two or three times and ensure that it operates properly.

Hydraulic Symbols

Table 6-3

Symbol	Description
	Filter
	Power unit
	Hydraulic motor

Symbol	Description
	Manual brake release valve
	Relief valve
	3-position 4-way solenoid directional valve
	2-position 2-way solenoid directional valve with hand operation
	2-position 4-way solenoid directional valve
	Running high and low speed reversing valve
	Flow regulator valve
	Check valve

Hydraulic Schematic Diagram

GTJZ0407SE hydraulic schematic diagram

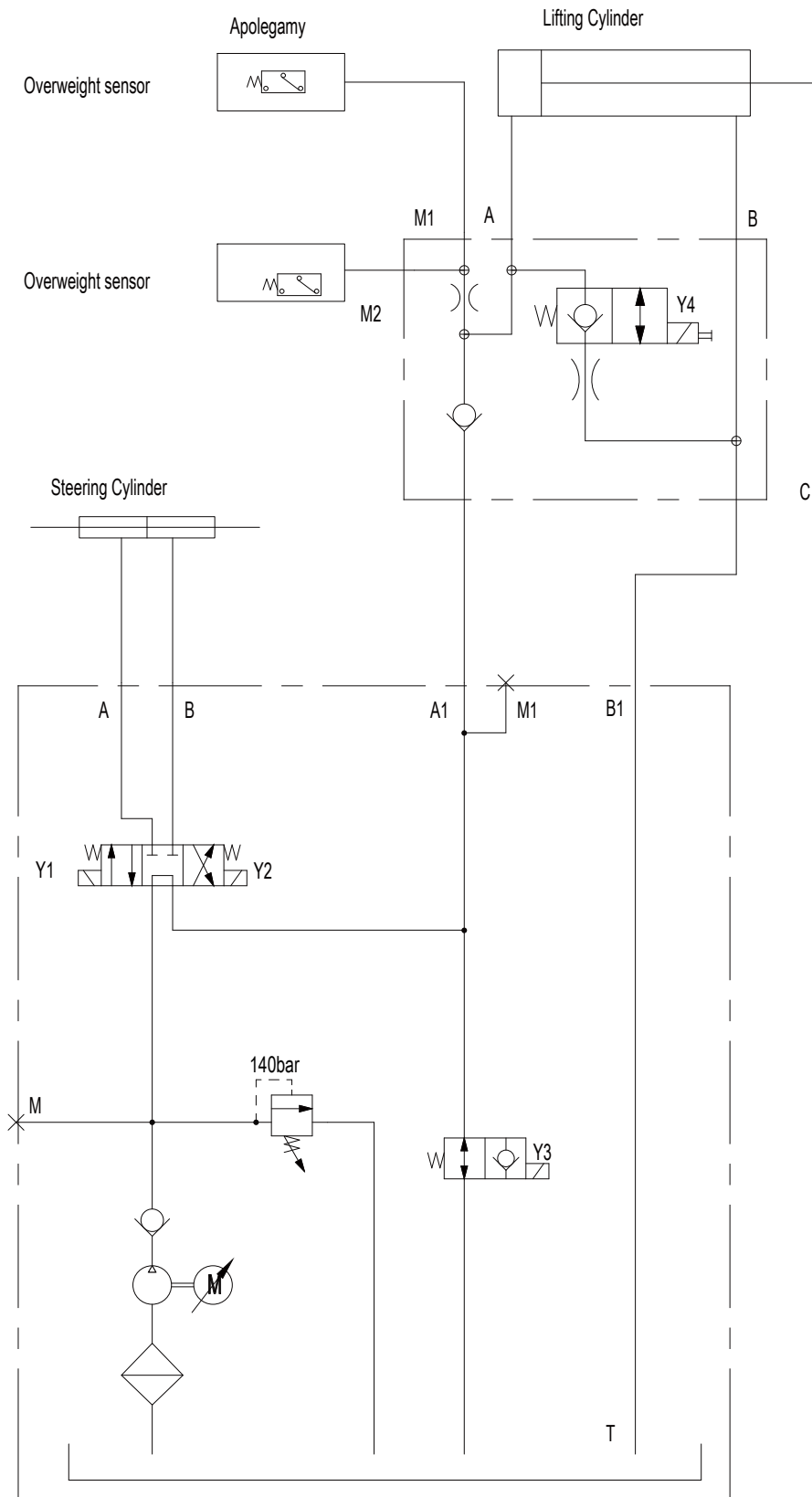

ELECTRICAL SYSTEM

Use and Maintenance of Battery

The battery falls into 3 types: lead acid, lead acid maintenance-free and lithium batteries. The lithium battery and lead acid maintenance-free battery are free of maintenance.

 **WARNING**

FIRE AND EXPLOSION HAZARD



- Batteries contain sulfuric acid and generate explosive mixtures of hydrogen and oxygen gases. Keep any device that may cause sparks or flames (including cigarettes/smoking materials) away from the battery to prevent explosion.



- Do not touch the battery terminals or cable clips with tools that may cause sparks.

 **WARNING**

ELECTROCUTION HAZARD



- Contact with hot circuit may cause serious injury or death. Be sure to wear goggles, gloves and protective clothing.



- Remove all rings, watches and other accessories.

 **WARNING**

CHEMICAL BURN HAZARD



- Avoid spilling or contacting battery acid with unprotected skin. Seek medical attention immediately if battery acid contacts skin.
- If the battery acid escapes, please use baking soda to neutralize the acid.

 **WARNING**

UNSAFE OPERATION HAZARD



- Strictly follow the manufacturer's recommendations on how to properly use and maintain the battery.



- Cut off the battery main switch if the battery is not to be used for an extended period.
- The waste battery may pose danger, do not discard at will. If it needs to be scrapped, contact a battery recycling company.
- Except for the professionals, do not perform a systematic maintenance or service to the battery, otherwise it may cause bodily injuries or damage to the battery system.
- Except for the professionals, do not tamper with the settings or service a signal light, otherwise it may cause bodily injuries or damage to the battery system.
- Except for the professionals, do not remove the battery housing, otherwise it may cause damage to the battery system.

NOTICE

It is not within the range of warranty if the battery attenuates or fails due to customer's overuse (- continued use after battery level less than 10%) or battery out of charge for a long time (not timely charged for 3 days or longer when the battery level less than 10%).

Inspection

See the *Inspect the Battery* section in this manual.

Cleaning

1. Clean the top, terminals and connections of the battery with a cloth or brush and mixed solution of sodium bicarbonate and water. Do not let the cleaning solution enter the battery.
2. Clean the top, terminals and connections with water and wipe them dry with a cloth. Apply a thin layer of petroleum jelly to the terminals or use terminal protector
3. Keep the area around the battery clean and dry.

Charging

See the **Charging the Battery** section of Operation Manual.

Equalizing

Equalization is the deliberate process of overcharging the flooded/wet battery after it has been fully charged. Equalize the battery only when the specific gravity of battery is low (less than 1.25) or the scope (0.030) of the specific gravity is wide after the battery is fully charged.

Note :

- Verify whether the battery is flooded/wet battery.
 - To prevent battery damage, the battery must be equalized within a maximum of 3 months storage after delivery.
1. Inspect the electrolyte level height to ensure a proper electrolyte level.
 2. Verify all vent caps are properly secured to the battery.
 3. Set the charger to equalization mode.
 4. Charge the battery in equalization mode.

The battery will bleed air in the equalization process (forming bubbles).

5. Remove the vent cap every hour to measure the gravity of all battery cells, if the gravity doesn't increase, stop the charging in equalization mode.

Storage

- Fully charge the battery before storage.
- The battery should be stored in cool and dry environment(temperature 10°C~25°C, RH less than 90%), and charge the battery every 3 months using the charger provided by the manufacturer.
- Disconnect the power-off plug to prevent potential parasitic loading, which may cause electrical leakage of the battery.
- The battery will self-discharge gradually during storage. Monitor the specific gravity or the voltage every 4 ~ 6 weeks. The comparison of the charging state with specific gravity and open-circuit voltage is shown in the following table.

Table 6-4

Percentage Charging (%)	Specific Gravity	Open-Circuit Voltage (V)		
		Battery Cell	6V	12V
100	1.277	2.122	6.37	12.73
90	1.258	2.103	6.31	12.62
80	1.238	2.083	6.25	12.50
70	1.217	2.062	6.19	12.37
60	1.195	2.040	6.12	12.24
50	1.172	2.017	6.05	12.10
40	1.148	1.993	5.98	11.96
30	1.124	1.969	5.91	11.81
20	1.098	1.943	5.83	11.66
10	1.073	1.918	5.75	11.51

- Recharge the battery in quick mode when the battery level is 70% or lower.
- Recharge the battery before use after removing it from storage.
- Storage in hot environments (above 32°C [90°F]): During storage, do not expose the battery directly to the heat source. The self-discharge process will accelerate in warmer temperatures. If storing the battery in hot temperatures or during hot weather monitor the specific gravity or the voltage more frequently (about every 2 - 4 weeks).
- Storage in cold environments (below 0°C [32°F]): During storage, do not store the battery in a place with an estimated temperature reaching the freezing point; if the battery has not been fully charged, it may freeze in cold temperatures. If storing the battery in cold temperatures or during cold weather, **fully charge** the battery. This point is very important.

NOTICE

- Do not store more than 6 months in hot or cold environment.
- It is not within the range of warranty if the battery attenuates or fails due to customer's overuse (-continued use after battery level less than 10%)

or battery out of charge for a long time (not timely charged for 3 days or longer when the battery level less than 10%).

Charger Troubleshooting

Fault code	Cause	Solution
E01 bAt	Output not connected to battery or reversely connected/short-circuited or damaged battery cell.	Check the battery pack is properly connected. Check the charger is properly connected. Check each battery cell for damage.
E02 AC	Abnormal civil power source (voltage)	Check the AC power cable is connected between the charger and AC outlet, ensure the AC plug is tightly connected to the AC outlet without loosening.
E03 Hot	Overtemp cutout of charger	When the charger inside or ambient temperature is too high, the charger will cut out and enter the overtemp cutout mode. Please place the charger in a well ventilated site. Disconnect the charger and wait 15–20min before recharging.
E04 bAt	Overtemp cutout of battery	When the battery temperature exceeds the preset value, the charger will cut out to prevent overheat. When the battery temperature is down, the charger will restart automatically.
E05 Err	Ouput overcurrent	Return for repair.
E06 bAt	Battery overvoltage	Check and ensure the battery is connected to the proper output voltage.

Trouble Diagnosis

display the machine parameter information and the trouble types.

A machine with this system has two display screens on the ground controller and platform control box. They

Table 6-5 Trouble Description and Inspection (SINOBOOM System)

Code	Problem	Action Limit	Solution
01	System initialization failure: the ground controller and platform handle display 001 fault, and the handle buzzer sounds	Disables All Motion	There may be some problems with the memory chip of the controller: power off to restart, if still unable to be resolved, replace the controller.
02	Communication fault : the ground controller and platform handle display 002 fault, and the handle buzzer sounds	Disables All Motion	Communication between controller and handle disrupted: check whether the wiring bewteen ECU controller and handle is disrupted; check whether the ECU controller and PCU handle plug is well connected; power off to restart, if still unable to be resolved, replace the controller.
12	ECU key fault: the ground controller and platform handle display E012 fault, and the handle buzzer sounds	Disable Chassis Control	After power-on, the ECU is operated without initializaiton or ECU fault: restart or check the ECU controller; check whether the ECU controller and PCU handle plug is well connected; power off

Code	Problem	Action Limit	Solution
			to restart, if still unable to be resolved, replace the controller.
18	Pothole guard fault: the ground controller and platform handle display E018 fault, and the handle buzzer sounds	Disable Lifting and Driving	After the platform is lifted, the pothole guard switch is still off or faulted, or the pothole guard switch wiring is disconnected: check whether the cables of pothole guard switch are broken; check whether the pothole guard switch is faulted; check whether the pothole guard plate extends/retracts properly.
31	Pressure sensor fault: the ground controller and platform handle display E031 fault, and the handle buzzer sounds	Disables All Motion	Pressure sensor wiring disrupted or pressure sensor damage: check whether the cables of pressure sensor are broken; check whether the current value of pressure sensor varies within the normal range.
32	Angle sensor fault : the ground controller and platform handle display E032 fault, and the handle buzzer sounds	Disables All Motion	Angle sensor wiring disrupted or angle sensor damage: check whether the cables of angle sensor are broken; check whether the current value of angle sensor varies within the normal range.
42	Steer left switch on before power-on : the ground controller and platform handle display E042 fault, and the handle buzzer sounds	Alarm only	When powering on, the left key on the handle is pressed: release all keys and power off to restart.
43	Steer right switch on before power-on : the ground controller and platform handle display E043 fault, and the handle buzzer sounds	Alarm only	When powering on, the right key on the handle is pressed: release all keys and power off to restart.
46	Enable switch on before power-on : the ground controller and platform handle display E046 fault, and the handle buzzer sounds	Disables Platform Control	When powering on, the enable switch on the handle is pressed or due to the handle jacket being inclined: release all keys and power off to restart.
47	Handle not returned to neutral before power-on : the ground controller and platform handle display E047 fault, and the handle buzzer sounds	Disable Lifting and Driving	When powering on, the handle not returned to neutral: release the handle and keep the handle in neutral position, and power off to restart.
52	Hydraulically driven machines drive forward solenoid valve fault : the ground controller and platform handle display E052 fault, and the handle buzzer sounds	Disable Lifting and Driving	Drive forward solenoid valve short or open circuited: check whether drive forward solenoid valve is short or open circuited; check the drive forward solenoid valve.
53	Hydraulically driven machines drive backward solenoid valve fault : the ground controller and platform handle display E053 fault, and the handle buzzer sounds	Disable Lifting and Driving	Drive backward solenoid valve short or open circuited: check whether drive backward solenoid valve is short or open circuited; check the drive forward solenoid valve.
54	Platform up solenoid valve fault : the ground controller and platform	Disable Lifting and Driving	Platform up solenoid valve short or open circuited: check whether platform up solenoid valve is short

Code	Problem	Action Limit	Solution
	handle display E054 fault, and the handle buzzer sounds		or open circuited; check the platform up solenoid valve.
55	Platform down solenoid valve fault : the ground controller and platform handle display E055 fault, and the handle buzzer sounds	Disables All Motion	Platform down solenoid valve short or open circuited: check whether platform down solenoid valve is short or open circuited; check the platform down solenoid valve.
56	Steer left solenoid valve fault : the ground controller and platform handle display E056 fault, and the handle buzzer sounds	Disable Lifting and Driving	Steer left solenoid valve short or open circuited: check whether steer left solenoid valve is short or open circuited; check the steer left solenoid valve.
57	Steer right solenoid valve fault : the ground controller and platform handle display E057 fault, and the handle buzzer sounds	Disable Lifting and Driving	Steer right solenoid valve short or open circuited: check whether steer right solenoid valve is short or open circuited; check the steer right solenoid valve.
68	Low battery level alarm : the ground controller and platform handle display E068 fault, and the handle buzzer sounds	Disables All Motion	The battery level is too low, please charge in time.
80	80% of rated load : the ground controller and platform handle display E080 fault, and the handle buzzer sounds	Alarm only	The platform load reaches 80% of the rated load.
93	BMS system fault : the ground controller and platform handle display E093 fault, and the handle buzzer sounds	Alarm only	BMS system faulted.
CL	Anti-collision switch alarm: the ground controller and platform handle display E0CL fault, and the handle buzzer sounds	Disable Lifting and Driving	Obstacles in way while lifting: remove the obstacles overhead or lower the platform.
OL	100% of rated load : the ground controller and platform handle display E0OL fault, and the handle buzzer sounds	Disable Lifting and Driving	The platform load reaches 100% of the rated load: reduce the weight applied to the platform and restart the system.
LL	Chassis tilted : the ground controller and platform handle display E0LL fault, and the handle buzzer sounds	Disable Lifting and Driving	The chassis angle exceeds the preset value: transfer the machine to level surface; check whether the angle sensor & wiring is faulted; check whether the ECU is loosely installed.

Table 6-6 Trouble Description and Inspection (DTC System)

Code	Problem	Action Limit	Solution
01	System initialization Fault	Disables All Motion	System Initialization Fault: ECU may be malfunctioning, replace it.
02	System communication Fault	Disables All Motion	System Communication Fault: Check communications cable connections and other wiring. If that does not resolve the problem, try replacing the PCU or ECU.
03	Invalid option setting Fault	Disables All Motion	Invalid Option setting Fault: Set appropriate option for this lift.

Code	Problem	Action Limit	Solution
04	Calibration Fault	Disables All Motion	Calibration Fault: Re-calibration the system, or check the angle and pressure sensor.
09	GPS communication Fault	Disables lift function	GPS communication Fault: Check communications cable connections and other wiring. If that does not resolve the problem, check the bound relationship or replace the GPS module.
12	Chassis Up or Down Switch ON	Disable Chassis Control	Chassis Up or Down Fault: Check communications cable connections and other wiring. If that does not resolve the problem, try replacing the ECU.
18	Pothole Guard Fault	Disable Lifting and Driving	Pothole Guard Fault: Check that the pothole guards are extended, check the pothole limit switches. Check wires to the switches, check the down limit switch and connections.
20	BMS Comm. Fault	Disable Lifting and Driving	BMS Comm. Fault: Check communications cable connections and other wiring.
21	Discharge Temperature Fault 1	Diagnostic Message Only	Discharge Temperature Fault 1: Tell BMS factory to check battery.
22	Discharge Current High Fault 1	Diagnostic Message Only	Discharge Current High Fault 1: Tell BMS factory to check battery.
23	Total Voltage Low Fault 1	Disable Lifting, and Driving on low speed	Total Voltage Low Fault 1: Tell BMS factory to check battery.
24	Cell Voltage Low Fault 1	Disable Lifting, and Driving on low speed	Cell Voltage Low Fault 1: Tell BMS factory to check battery.
25	Cell Voltage Low Fault 2	Disable Lifting and Driving	Cell Voltage Low Fault 2: Tell BMS factory to check battery.
26	Sharp Difference in Voltage	Disable Lifting and Driving	Sharp Difference in Voltage: Tell BMS factory to check battery.
27	Sharp Difference in Temperature	Disable Lifting and Driving	Sharp Difference in Temperature: Tell BMS factory to check battery.
28	Discharge Current High Fault 2	Disable Lifting and Driving	Discharge Current High Fault 2: Tell BMS factory to check battery.
29	Discharge Temperature Fault 2	Disable Lifting and Driving	Discharge Temperature Fault 2: Tell BMS factory to check battery.
31	Pressure Sensor 1 Fault	Disables All Motion	Pressure Sensor 1 Fault: Check the wiring to the sensor and then the sensor itself. Also check to make sure that the correct option is properly selected (or not) for load sensing.
32	Angle Sensor Fault	Disables All Motion	Angle Sensor Fault: Check the wiring to the sensor and then the sensor itself. Also check to make sure that the correct option is properly selected (or not) for load sensing.
35	Pressure Sensor 2 Fault	Disables All Motion	Pressure Sensor 2 Fault: Check the wiring to the sensor and then the sensor itself. Also check to make sure that the correct option is properly selected (or not) for load sensing.

Code	Problem	Action Limit	Solution
36	Battery Drain Alarm	Lift Slow to Drive Speed	Battery Drain Alarm: Battery voltage is low, charge the battery.
37	Battery Drain Shutdown	Disables All Motion	Battery Drain Shutdown: Battery enters into sleep mode, and operate the joystick or button on ECU controller to quit the mode.
42	Platform Left Button ON	Diagnostic Message Only	Platform Left Turn Switch ON at power-up Message: Ensure that nothing is holding the Joystick Toggle Switches down. If OK, consider replacing the Joystick or PCU.
43	Platform Right Button ON	Diagnostic Message Only	Platform Right Turn Switch ON at power-up Message: Ensure that nothing is holding the Joystick Toggle Switches down. If OK, consider replacing the Joystick or PCU.
46	Platform Enable Button ON	Disable Platform Control	Platform Joystick Enable Switch ON at power-up Fault: Ensure that nothing is holding the Enable switch closed. Also check the neutral zone parameters. If OK, consider replacing the Joystick or PCU.
47	Joystick Not In Neutral	Lift Slow to Drive Speed	Platform Joystick not in neutral at power-up Message: Make sure that the Joystick is in the neutral (upright) position. Check the neutral zone parameter setting in the LabView Programmer. If it's OK, consider replacing the Joystick or the PCU.
52	Forward Coil Fault	Disable Lifting and Driving	Forward Coil Fault: Check the connections to the Coil's terminals and make sure they are tight. If so, check the coil itself to see if it is open or shorted.
53	Reverse Coil Fault	Disable Lifting and Driving	Reverse Coil Fault: Check the connections to the Coil's terminals and make sure they are tight. If so, check the coil itself to see if it is open or shorted.
54	Lift Up Coil Fault	Disable Lifting and Driving	Lift Up Coil Fault: Check the connections to the Coil's terminals and make sure they are tight. If so, check the coil itself to see if it is open or shorted.
55	Lift Down Coil fault	Disable Lifting and Driving	Lift Down Coil Fault: Check the connections to the Coil's terminals and make sure they are tight. If so, check the coil itself to see if it is open or shorted.
56	Right Turn Coil Fault	Disable Lifting and Driving	Right Turn Coil Fault: Check the connections to the Coil's terminals and make sure they are tight. If so, check the coil itself to see if it is open or shorted.
57	Left Turn Coil Fault	Disable Lifting and Driving	Left Turn Coil Fault: Check the connections to the Coil's terminals and make sure they are tight. If so, check the coil itself to see if it is open or shorted.
58	General Brake Coil Fault	Disable Lifting and Driving	General Brake Coil Fault: Check the connections to the Coil's terminals and make sure they are tight. If so, check the coil itself to see if it is open or shorted.
59	Parallel Coil Fault	Disable Lifting and Driving	Parallel Coil Fault: Check the connections to the Coil's terminals and make sure they are tight. If so, check the coil itself to see if it is open or shorted.

Code	Problem	Action Limit	Solution
60	Motor Controller Fault	Disable Lifting and Driving	Motor Controller Fault : Check the connections to motor and make sure they are tight. If so, check there are other detail faults.
61	Motor Controller Current Sensor Fault	Disable Lifting and Driving	Motor Controller Current Sensor Fault: Drive or Lift Motor may be overheating. Let the lift cool down. If that does not help, cycle power to reset the Motor controller. If the problem persists, check the wiring and if OK, try replacing the Motor Controller.
62	Motor Controller Hardware Failsafe Fault	Disable Lifting and Driving	Motor Controller Hardware Failsafe Fault: Cycle power. If that does not resolve the issue check for noise sources. If still needed, try replacing the Motor Controller.
63	Motor Controller Motor Short Fault	Disable All Motion	Motor Controller Motor Short Fault: Check wiring first then cycle power. If needed replace controller.
64	Motor Controller SRO Fault	Disable Lifting and Driving	Motor Controller SRO Fault: Look at motor enable delay with the Scissor Programmer, it may be too short. Make sure other Motor Controller parameters are properly selected.
65	Motor Controller Throttle Fault	Disable All Motion	Motor Controller Throttle Fault: Check wiring. Make sure the correct throttle type is selected in the Motor Controller.
66	Motor Controller Emergency Reverse Fault	Disable All Motion	Motor Controller Emergency Reverse Fault: Ensure that the Emergency Reverse Check parameter is off in the Motor Controller.
67	Motor Controller HPD Fault	Disable All Motion	Motor Controller HPD Fault: Look at motor enable delay with the Scissor Programmer, it may be too short. Make sure other Motor Controller parameters are properly selected.
68	Total Voltage Low Fault 2	Disable All Motion	Total Voltage Low Fault 2: Check battery voltage and charge if necessary. Check the battery connections and tight or clean. Check the voltage to the ECU and PCU.
69	High Neutral Current Fault (Zapi Only)	Disable Lifting and Driving	High Neutral Current: The MC is sensing current in the motors when there should not be. This could occur anytime the MC thinks the brakes are on and the motors are still turning. This message sometimes comes just before other faults but should be ignored in those cases.
70	Steer Input Out of Range (Zapi Only)	Disable Lifting and Driving	Steering Input Out of Range: There is an inappropriate voltage at the steering input of the ZAPI motor controller. The ZAPI may need to be "trained" for the three steering voltages (on Differential Steered machines). Or the steering voltage from the ECU was at some point outside of the range that was recorded during the "training" session. Re- train the ZAPI and/or check for fluctuating voltages due to lose wires, etc.
71	Motor Controller Main Contractor Fault	Disable Lifting and Driving	Motor Controller Main Contactor Fault: Check the connections to the main contactor. Replace the contactor if necessary. Replace the Motor Controller if necessary.

Code	Problem	Action Limit	Solution
72	Motor Controller Over Voltage Fault	Disable Lifting and Driving	Motor Controller Over Voltage Fault. Check battery voltage and make sure the battery charger is not on. Then cycle power to the lift. If that does not resolve the issue, try replacing the Motor Controller.
73	Motor Controller Thermal Cutback Fault	Disable All Motion	Motor Controller Thermal Cutback Fault: Drive or Lift Motor may be overheating. Let the lift cool down. If that does not help cycle power to reset the Motor controller. If that doesn't resolve the issue, replace the Motor Controller
74	Motor Controller Over Heat Fault	Disable All Motion	Motor Controller Motor Fault: Check connections to the motors. Cycle power to the lift and if that does not resolve the issue, replace the Motor Controller.
75	Motor Controller Pump Motor Fault	Disable All Motion	Motor Controller Pump Motor Fault: Check connections to the Pump Motor. Cycle power to the lift and if that does not resolve the issue, replace the Motor Controller.
76	Motor Controller Left Drive Motor Fault	Disable All Motion	Motor Controller Left Drive Motor Fault: Check connections to the motors. Cycle power to the lift and if that does not resolve the issue, replace the Motor Controller.
77	Motor Controller Right Drive Motor Fault	Disable Lifting and Driving	Motor Controller Right Drive Motor Fault: Check connections to the motors. Cycle power to the lift and if that does not resolve the issue, replace the Motor Controller.
78	Pump Motor Short Fault	Disable Lifting and Driving	Pump Motor Short Fault: Check connections to the pump motor. Cycle power to the lift and if that does not resolve the issue, replace the Motor Controller.
79	Left Drive Motor Short Fault	Disable All Motion	Left Drive Motor Short Fault: Check the Motor connections and make sure they are tight. Check the Motor for a short.
80	Over 82% Load Warning	Warning Only	Over 80% Load Warning: Platform is getting close to its limit of weight. Consider not adding more load.
81	Right Drive Motor Short Fault	Disable All Motion	Right Drive Motor Short Fault: Check the Motor connections and make sure they are tight. Check the Motor for a short.
82	Left Brake Coil Fault	Disable Lifting and Driving	Left Brake Coil Fault: Check the connections to the Coil's terminals and make sure they are tight. If so, check the coil itself to see if it is open or shorted.
83	Right Brake Coil Fault	Disable Lifting and Driving	Right Brake Coil Fault: Check the connections to the Coil's terminals and make sure they are tight. If so, check the coil itself to see if it is open or shorted.
84	Motor Post Shorted	Disable Lifting and Driving	Motor Post shorted: Check the connections of the controller and motor. Make sure the wiring is not shorted.
85	Brake Release Switch On	Diagnostic Message Only	Brake Release Switch On: Check the wires to brake release switch or look for a stuck switch.

Code	Problem	Action Limit	Solution
86	Brake Release Switch On	Diagnostic Message Only	Brake Release Not Stowed: Check if the platform is below down limit height. Check the down limit switch and connections.
87	Brake Release Not Showed	Diagnostic Message Only	Brake Release Need Switch On: Check the wires to brake release switch or look for a stuck switch. Check the wires to the Toggle Switch or look for a stuck Toggle Switch.
89	Motor Field Open	Disable Lifting and Driving	Motor Field Open: The field voltage is different from 1/2 Vbatt. Check connections of the field wires or leakage to the vehicle frame.
90	Over 90% Load Warning	Warning Only	Over 90% Load Warning: Platform is getting close to its limit of weight. Consider not adding more load.
91	Left Motor Field Short	Disable Lifting and Driving	Left Motor Field Short: Check connections of the field wires or leakage to the vehicle frame.
92	Right Motor Field Short	Disable Lifting and Driving	Right Motor Field Short: Check connections of the field wires or leakage to the vehicle frame.
99	Over 99% Load Warning	Warning Only	Over 99% Load Warning: Platform has reached its limit of weight. Do not add more load.
OL	Overloaded Platform Fault	Disable All Motion	Overloaded Platform Fault: Remove the excess load immediately.
OH	Platform Highest Position Warning	Disable Lifting	Platform Highest Position Warning: Lower the machine.
LL	Machine Tilted	Disable Lifting and Driving	Machine Tilted Beyond Safe Limits Fault: If the machine is tilted, find a way to make it level. If the machine is level, check the wiring to the tilt sensor and then the sensor itself.
Ft	Foot pedal no action	Disable PCU Control	Foot pedal no action: when operate the joystick to drive and lift, there is no action on foot pedal, so please check the switch of foot pedal.
CL	Anti-collision switch warning	Disable Lifting and Driving	Anti-collision switch warning: When lifting up and close to the obstacle, warning and check the anti-collision switch.

Fundamental Troubleshooting

Table 6-7

Problem	Cause	Solution
The power indicator lamp is not illuminated	The equipment has not been powered on	<ul style="list-style-type: none"> • The key switch is in the OFF position. • The platform controller or the ground controller emergency stop button is in the OFF position. • The platform controller is malfunctioning or not powered off after downloading of a program. • The ground controller is malfunctioning or not powered off after downloading of a program.
The power indicator lamp is not lit	CAN equipment is offline	<ul style="list-style-type: none"> • Inspect whether the leads of the power supply and communication are inserted properly and reliably. • Inspect whether all pins of the Deutsch plugs for the platform controller and ground controller connecting cables are wired according to the drawing. • Inspect whether the platform controller plug or the plug of the connecting cable between the platform controller and ground controller are in good contact. • Inspect whether the platform controller is malfunctioning. • Inspect whether the Deltatech plug of ground controller is firm or correct.
Operation of the ground controller is invalid	The key switch has not been turned to the operation of the ground control position	<ul style="list-style-type: none"> • The key switch is not placed on the ground control position. • The system has not been powered off after the program is downloaded to the platform controller.
Operation of the platform controller is invalid	The key switch has not been turned to the operation of the platform control position	<ul style="list-style-type: none"> • The key switch is not placed on the ground control position. • The system has not been powered off after the program is downloaded to the platform controller. • Inspect whether the platform controller is malfunctioning.
Level status tilting is always sounding alarm	The level switch has not been connected or has trouble	<ul style="list-style-type: none"> • Inspect whether the level switch is inserted properly and firmly. • Inspect whether the level switch is malfunctioning.
The ground controller does not lower when the machine has no load and is level	The lowering valve has trouble	<ul style="list-style-type: none"> • Inspect whether the on-off input plug is inserted properly and firmly. • Inspect whether the wiring of the plug switch is malfunctioning. • Inspect whether the connection of the lead of the lifting valve is wrong, and whether the lowering valve is malfunctioning.



Problem	Cause	Solution
The platform controller does not lower when there is no alarm	The platform is limited to 1.2 m	Reset the handle and resume lowering.
The platform controller does not lower when the machine has no load and is level	Height calibration is wrong/ lifting valve has trouble	<ul style="list-style-type: none"> Inspect whether the on-off input plug is inserted properly and firmly. Inspect whether the wiring of the plug switch is malfunctioning. Re-calibrate the height. Inspect whether the connection of the lead of the lifting valve is wrong, and whether the lifting valve is malfunctioning.
The platform does not lift to the maximum position when the machine has no load and is indoors	The height has not been calibrated/the travel switch is incorrect	<ul style="list-style-type: none"> Re-calibrate the height. Change the setting of the travel switch.
The platform refuses to rise further after reaching a certain position	The travel switch setting is incorrect	Reset the travel switch.
An overweight warning appears when the machine has no load	The load has not been calibrated/this is the first lifting/lowering	<ul style="list-style-type: none"> Re-calibrate the load coefficient. Lift and lower it several times.
The forward function fails without a warning	The forward moving capability is malfunctioning	<ul style="list-style-type: none"> Check whether the PWM plug of the controller on the lower platform is inserted correctly and solidly. Check whether the connection of the forward valve is normal. Inspect whether the platform controller is malfunctioning.
The backward function fails without a warning	The backward moving capability is malfunctioning	<ul style="list-style-type: none"> Check whether the PWM plug of the ground controller is inserted correctly and solidly. Check whether the connection of the forward valve is normal. Inspect whether the lower platform controller is malfunctioning.
There is no warning after descending to the minimum limiting position	Pothole protector	<ul style="list-style-type: none"> The high-speed hydraulic valve is connected incorrectly. The installation of the travel switch is abnormal. The hydraulic valve is malfunctioning.
Tilting warning	The level switch is abnormal	<ul style="list-style-type: none"> The level switch air bubble is not in the middle position. The level switch is not connected properly or firmly. The ground controller is malfunctioning.

Problem	Cause	Solution
No overload warning	The load has not been calibrated or the height is incorrect	<ul style="list-style-type: none"> • The sensor has not been calibrated. • The wiring of the load sensor is incorrect. • The sensor is not in good condition.
The machine moves and then stops intermittently	The battery level is low/the calibration is incorrect	<ul style="list-style-type: none"> • Re-calibrate the parameters. • The battery is out of power. The electricity meter only can be referred.
After setting, the parameters could not be saved successfully after several trials.	The storage is abnormal	<ul style="list-style-type: none"> • The parameters cross the line. • The lower platform controller is malfunctioning.

Electrical Symbols

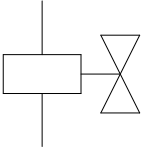
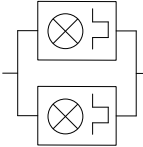
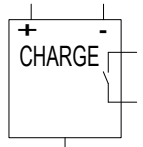
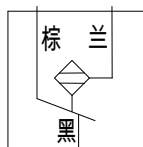
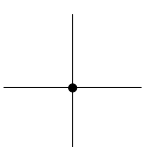
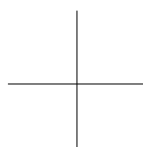
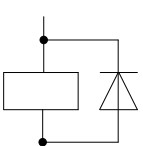
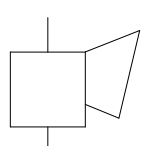
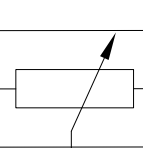
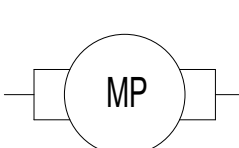
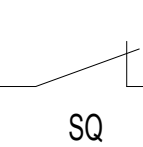
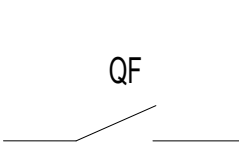
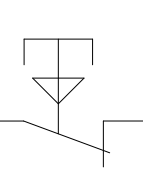
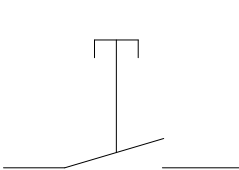
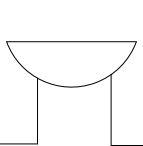
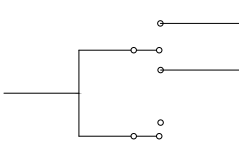
Table 6-8

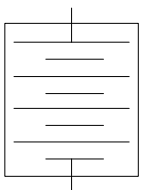
Symbol	Description	Symbol	Description
	Solenoid coil		Warning lamp
	Charger		Level switch
	Two lines connected		Two lines non-connected
	Relay		Horn
	Sensor		Pump control motor
	Limit switch		Power off button
	Emergency stop button		Button
	Buzzer		Key switch

Symbol	Description
	Storage battery
	Fuse

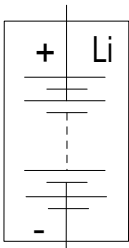
Symbol	Description
	Lithium battery

Electrical Schematic(DTC-K300 & CANPLUS)

power socket | battery&charger | cut off switch | fuse | moto controller

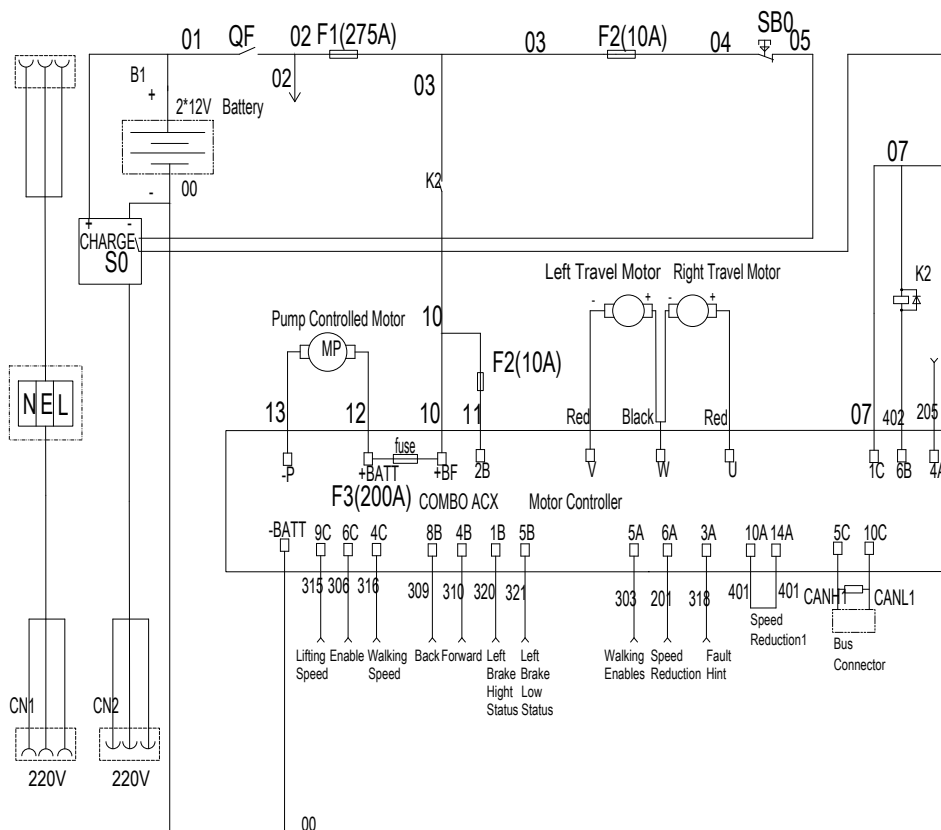

power outconnector | charger plug

emergency stop key switch controller power down limit up limit Pothole Switch hole switch level sensor buzzer Angle sensor Press Sensor Press Sensor2 PCU

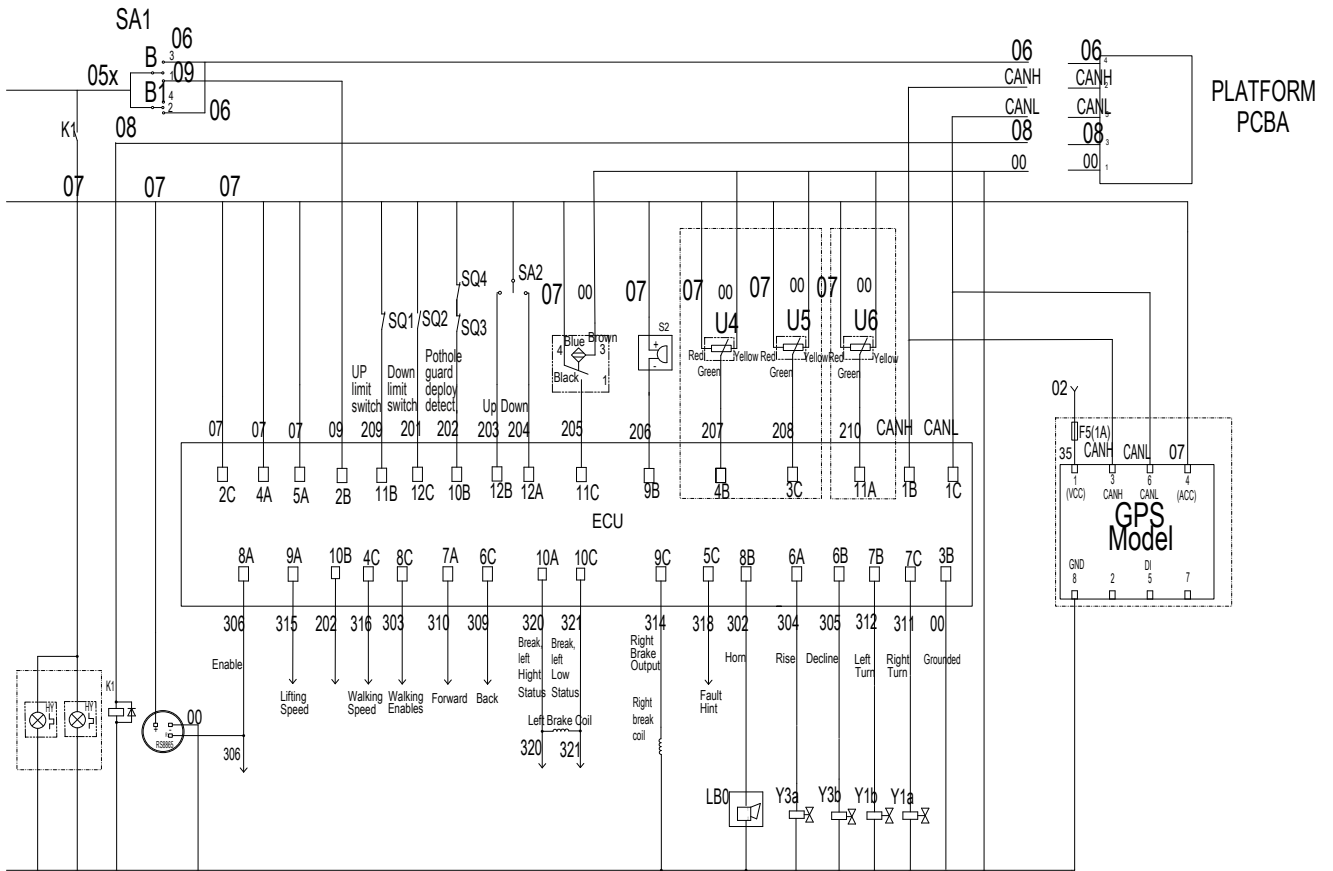

flash light relay hour meter left braking coil right braking coil troubleshooting horn rise drop turn left turn right GPS

Electrical Schematic (DTC-K500/
SINOBOOM)

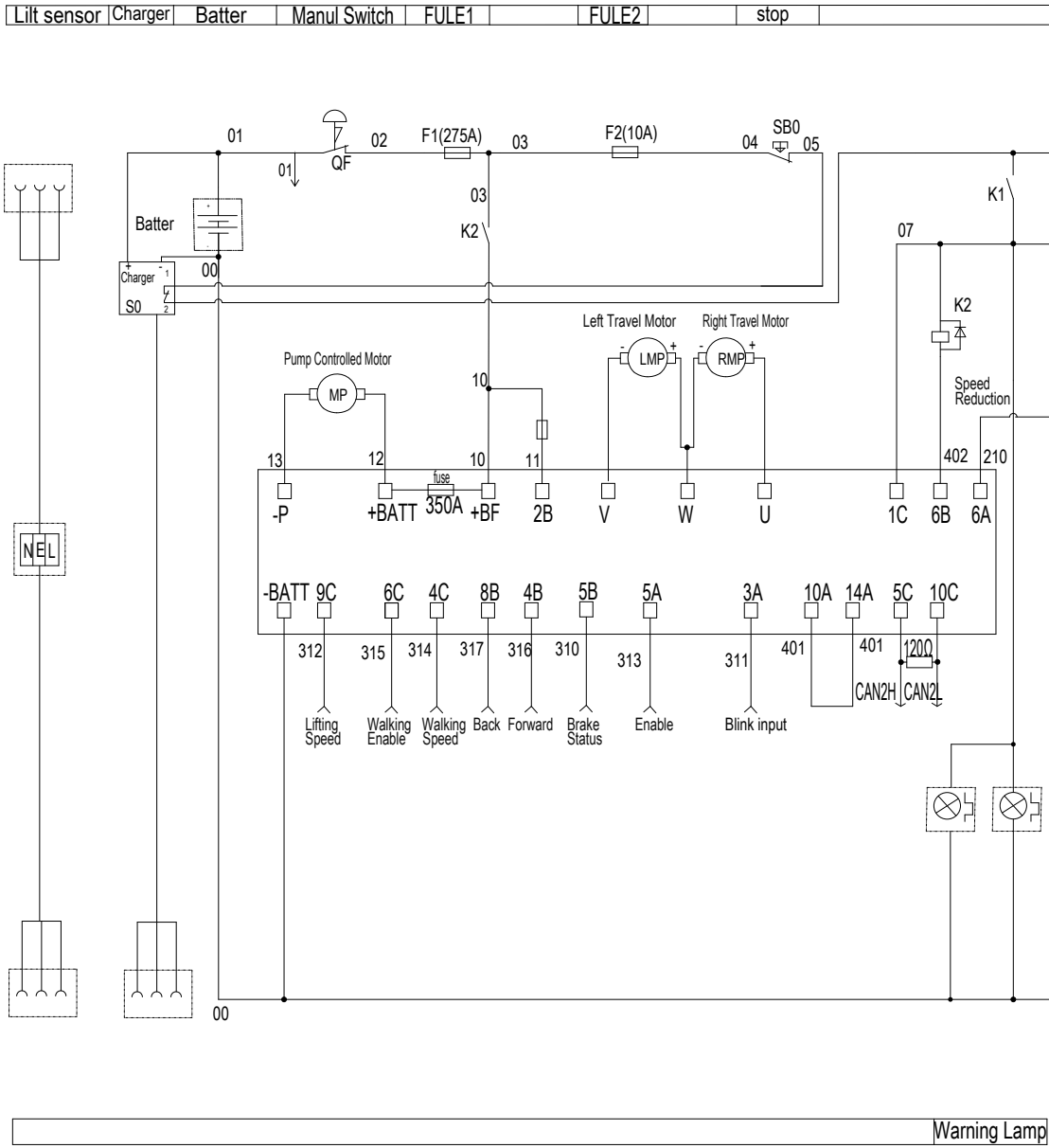

Warning Lamp

Down limit switch | Key switch | Up limit switch | Pot hole limit switch | Height limit drive | Foot Pedal | Collision | Lift sensor | Buzzer | Angle sensor | Pressure sensor 1 | Pressure sensor 2 | Communication | PCU

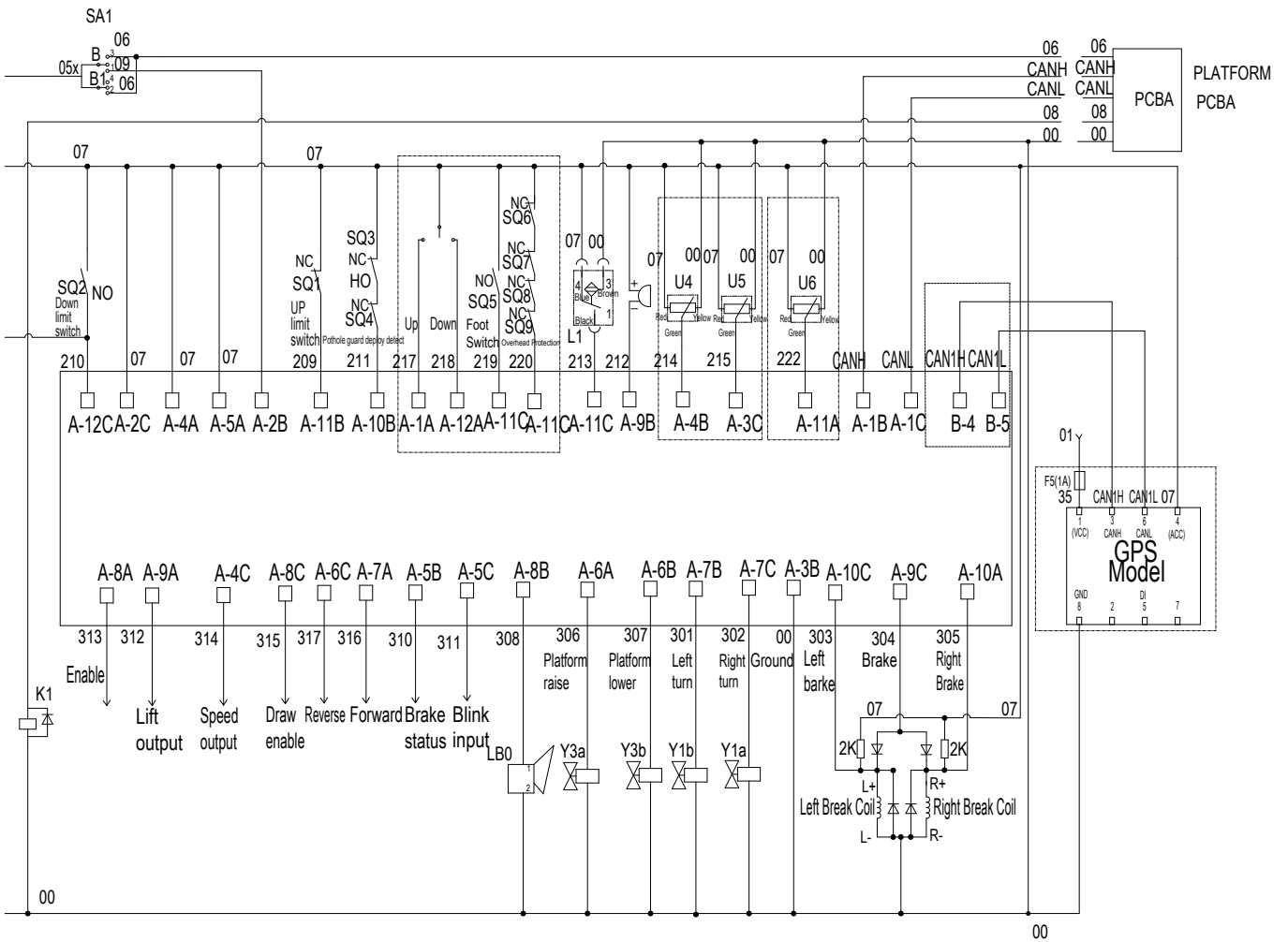

Relay 1 | Enable | Lift output | Speed output | Draw Enable | Reverse | Forward | Brake status | Blink input | Horn | Platform raise | Platform lower | Left turn | Right turn | Ground | Left barke | Brake | Right Brake

This Page Intentionally Left Blank

APPENDIX 1: PREPARE THE WORK RECORD BEFORE DELIVERY

PREPARE THE WORK RECORD BEFORE DELIVERY			
Model			
Serial No.			
Inspection Item	YES/Machine is in Good Condition	NO/Machine Has Damage or Malfunction	REPAIRED/Machine Has Been Repaired
Pre-operational Inspection			
Maintenance Procedure			
Functional Inspection			
Machine Buyer/ Renter			
Inspector Signature			
Inspector Title			
Inspector Company			
<p>NOTE:</p> <ol style="list-style-type: none"> 1. Prepare the machine before delivery, which includes performing a pre-delivery inspection, following maintenance procedures and performing functional inspections. 2. Use the table to record the results. After each section is complete, mark the appropriate box. 3. Record the inspection results. If any inspection results are "NO", the machine must be stopped and re-inspected after repair is completed and marked in the box marked "inspection". 			

This Page Intentionally Left Blank

APPENDIX 2: REPAIR & INSPECTION REPORT

REPAIR & INSPECTION REPORT				
Model				
Serial No.				
Checklist A Procedures				
Items	YES/Machine is in Good Condition	NO/Machine Has Damage or Malfunction	REPAIRED/ Machine Has Been Repaired	Problem Description
A-1 Inspect All Manuals				
A-2 Inspect All Decals				
A-3 Inspect Damaged, Loose or Lost Parts				
A-4 Inspect Hydraulic Oil Level				
A-5 Inspect Hydraulic Oil Leakage				
A-6 Functional Tests				
A-7 Inspect the Battery Level				
A-8 Perform Maintenance After 30 Days				
Checklist B Procedures				
Items	YES/Machine is in Good Condition	NO/Machine Has Damage or Malfunction	REPAIRED/ Machine Has Been Repaired	Problem Description
B-1 Inspect Electric Wires				
B-2 Inspect Rim ,Tire and Fasteners				
B-3 Inspect Battery				
B-4 Inspect Hydraulic Oil				
B-5 Inspect Hydraulic Tank Air Filter				
B-6 Inspect Manul Brake Release				
B-7 Inspect Emergency Lowering				
B-8 Inspect Braking Device				

REPAIR & INSPECTION REPORT				
B-9 Test Lift/Lower Speed				
B-10 Test Drive Speed				
B-11 Inspect Tilt Protection				
B-12 Inspect Pothole Guards				
Checklist C Procedures				
Items	YES/Machine is in Good Condition	NO/Machine Has Damage or Malfunction	REPAIRED/ Machine Has Been Repaired	Problem Description
C-1 Replace Hydraulic Oil Tank Air Filter				
C-2 Inspect Platform Weighing System				
C-3 Inseptct Lift Limit Switch				
C-4 Inspect Staged Lowering				
Checklist D Procedures				
Items	YES/Machine is in Good Condition	NO/Machine Has Damage or Malfunction	REPAIRED/ Machine Has Been Repaired	Problem Description
D-1 Inspect Scissor Arm Installation Bearing				
D-2 Inspect Chassis Slider				
D-3 Replace Hydraulic Oil				
User				
Inspector Signature				
Inspector Date				
Inspector Title				
Inspector Company				
NOTES:				
<ol style="list-style-type: none"> 1. The Repair & Inspection Report shall include the inspection table of each regular inspection. 2. Duplicate the Repair & Inspection Report for each inspection. Store the completed tables for 10 years or until the machine is no longer in use or as required by machine owner/company/custodian. 3. Use the table to record the results. After each section is complete, mark the appropriate box. 4. Record the inspection results. If any inspection results are "NO", the machine must be stopped and re-inspected after repair is completed and marked in the box marked "inspection". <p>Select the appropriate inspection procedure based on the inspection type.</p>				

Always for Better Access Solutions



Hunan Sinoboom Intelligent Equipment CO.,Ltd.

No.128, East Jinzhou Avenue, Ningxiang High-tech Industrial Park, Changsha, Hunan, China

☎ 0086-0731-87116222 (Sales) & 0086-0731-87116333 (Service)

✉ sales@sinoboom.com

🏠 www.sinoboom.com

North American Subsidiary

Sinoboom North American LLC

310 Mason Creek Drive
unit #100
Katy, TX 77450, US
Tel: (281) 729-5425
E-mail: info@sinoboom.us

Europe Subsidiary

Sinoboom B.V.

Nikkelstraat 26, NL-2984 AM Ridderkerk,
The Netherlands
Tel: +31 180 225 666
E-mail: info@sinoboom.eu

Korea Subsidiary

Sinoboom Korea Co., Ltd.

95, Docheong-ro, Yeongtong-gu, Suwon-
si, Gyeonggi-do, Republic of Korea
Tel: 010-8310-8026
E-mail: ka1@sinoboom.com

Australia Subsidiary

Sinoboom Intelligent Equipment Pty Ltd.

50/358 Clarendon St, South Melbourne
VIC 3205, Australia
E-mail: au@sinoboom.com

Singapore Subsidiary

Star Access Solutions Pte. Ltd.

112 Robinson Road #03-01 Robinson 112
Singapore 068902

Poland Subsidiary

Sinoboom Poland sp. z o.o.

Ul. Bolesława Krzywoustego 74A
61-144 Poznań, Poland