

INSTRUCTION MANUAL PROFESSIONAL

M7T DIGITAL CONTROL UNIT



HIMOINSA

CONTENTS

- 3** 1. Introduction
- 5** 2. Front of the control unit
- 7** 3. Operating modes
- 8** 4. Operations
- 14** 5. Inputs and Outputs
- 22** 6. List of alarms
- 30** 7. Maintenance
- 33** 8. Appendix I: table of parameters
- 39** 9. Appendix II: screens of the M7T CONTROL UNIT
- 49** 10. Appendix III: dimensions, wiring and mechanical parts

1. INTRODUCTION

The M7T control unit is an electronic generator set power supervision and control device. The control unit consists of a compact module that performs the following functions:

- **User interface.** The M7T control unit displays information regarding the status of the device and allows actions to be performed by the user; the display module allows the user to control the control unit, as well as to program and configure the functions. The user interface allows the user to access a log of the last 100 errors registered in the control unit; the details of generator set status during the last 10 errors are also stored among these.
- **Generator set control.** The M7T control unit performs generator set supervision and control tasks. The control tasks include engine management and safe generation of electrical power. All the signs, sensors and actuators are wired to the rear of the M7T control unit (see illustrations in Annex III).
- **Control of outputs from the lighting tower.** The M7T control unit manages the outputs from the lighting tower. This allows you to configure the sequential switching on and shutdown of outputs to avoid overloads at the generator output. It is possible to detect dead bulbs by the reduction in the measured consumption. It takes account of the cooling times of the lights, delaying switching them on by the time programmed after they are shut down. It has programmable inputs to control outputs.

The control unit provides the following characteristics for the electrical signal generated by both the generator set and the electrical grid:

- Phase-neutral voltage
- Phase-to-phase voltage
- Phase-to-phase current
- Active, apparent and reactive power
- Power factor



The M7T control unit provides the following engine features:

1. Engine alarm inputs:

- Fuel reserve
- Oil pressure
- Water temperature
- Water level
- Emergency stop (mushroom head stop button)

2. Analogue inputs of the engine:

- Fuel level
- Pressure
- Temperature
- Charge-battery alternator voltage
- Battery voltage

3. Start-up inputs: The M7T control unit has an input that orders generator set start-up and is managed in automatic mode.

4. Configurable inputs: the inputs of the M7T control unit are all programmable (except the analogue input for the fuel level -NC- and the emergency stop digital input -PE-) to perform the following functions:

- 2 programmable alarms
- Second configuration
- Forced operation
- Emergency stop
- Confirm generator set contactor
- Control lighting outputs

5. Generator set outputs; the measurement board has 5 outputs that can be programmed for the following functions:

- Preheating
- Stopping
- Start-up
- PULL and HOLD outputs for YANMAR engines
- Alternator activation
- Alarm

6. Configurable outputs; the measurement board has 3 outputs that can be programmed for the following functions:

- Electronic protection
- Dummy load
- Transfer pump
- Engine started
- Genset contactor

7. Engine statistics:

- Operating hours
- Number of start-ups
- Energy generated

The M7T control unit provides the following lighting control outputs:

8. Lighting control outputs; there are 4 PNP outputs of up to 1A.



2. FRONT OF THE CONTROL UNIT

The M7T control unit has a backlit display with a resolution of 128x64 and several LEDs to view generator set status. It also has buttons that allow the user to control and program the control unit.

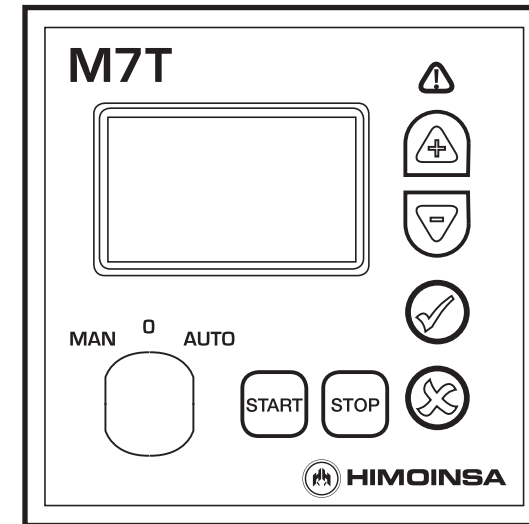

Fig.1
Front of the M7YSAR control unit

1. Backlit display with 128x64 pixel resolution

NOTE:

The display goes into low power mode (backlight off) after 10 minutes have passed without any button being pressed.

2. User interface

- Alarms management key
- Control unit command keys (start/stop)
- Menu keys
- Control unit mode key

3. Status LEDs

- Alarm LED



2.1 CONTROL UNIT BUTTONS

2.1.1 CONTROL UNIT MODE SELECTION KEY

Control unit modes:

- **Automatic mode.** The control unit monitors the status of the genset and manages its operation and the programmable inputs.
- **Manual mode.** The control unit is commanded by the user.
- **Mode 0.** The control unit is turned off by commanding a generator set stop.

2.1.2 CONTROL UNIT COMMAND BUTTONS



Engine start button (only in manual mode)
Manages start-up with one touch.



Engine stop button (only in manual mode)
The first press to stop engine while performing a cooling cycle.
The second press to stop the engine immediately.

2.1.3 DISPLAY BUTTONS



Confirm. Accesses the menus and validates the data that are entered. Notify. Deletes non-active alarms from the alarms display page.



Cancel. Goes back through menus and cancels data entered. Alarms. Go to the alarms display page.



Up. Advances through the selection of display screens, the maintenance menu selection and increases the programmed values.



Down. Goes back through the selection of display screens, the maintenance menu selection and decreases the programmed values.

2.2 STATUS LEDS

2.2.1 ALARMS LEDS



Control unit status

Fixed: Alarm active
Flashing: Alarm inactive pending notification
Off: No alarm

NOTE

For more details, see the Alarms section

2.3 PASSWORDS

The M7T control unit has 2 levels of 4-digit passwords to protect against unauthorized access. The different levels of access are as follows:

- **User** (default password: 1111). User level access allows the operator to access the main menu of the M7T control unit.
- **Maintenance** (default password: 1911). Maintenance level access allows the operator to access the Parameters programming option from the main menu.

The M7T control unit's passwords are customizable by the user from the main menu. A user can configure both passwords for their access level and lower-level passwords.

NOTE

To enter a password, see Appendix II: Password entry



3. OPERATING MODES

3.1 MANUAL MODE

In manual mode, the control unit is commanded by the user via the front panel. The user can start and stop the engine by pressing the START and STOP keys respectively.

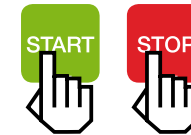

Pressing the START key initiates the engine start-up operation. Pressing the STOP key initiates the engine stop operation with cooling; a second press of the STOP key causes the engine to stop immediately without waiting for the cooling time.

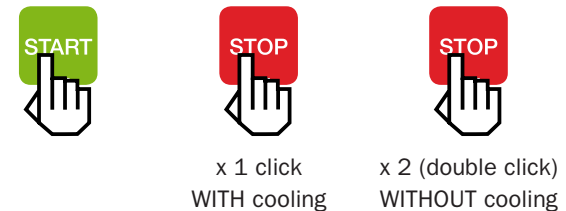

NOTE

In manual mode, the control unit's protection devices remain active, being able to produce alarms that cause the engine to stop. In manual mode, the control unit does not take into consideration the start-up conditions (programmed, by external signal) that can be programmed.

3.2 AUTOMATIC MODE

In automatic mode, supervision of the installation is managed by the control unit. Under certain circumstances which can be programmed, the control unit starts the genset to supply the installation.

Programmable conditions for genset start-up and activation of the genset contactor include:

- External start-up
- Forced operation signal (Configuration table, parameter 110 and 120 or 121)
- Programmed start time (only M7TR control unit)



4. OPERATIONS

4.1 ENGINE OPERATIONS

4.1.1 ENGINE START-UP

To activate the control unit, perform the following engine start-up operation:

1. **Start-up delay.** If the control unit's start-up condition is a programmed input, such as an external start-up function, a start-up delay can be programmed (Times table - parameter 409); this activates the alarm output to indicate engine start-up during that time.
2. **Preheating the engine.** The control unit activates the preheating output (PR) for the programmed time (Times table - parameter 402).
3. **Enabling the starting of the engine (positive contact activation).** Engine start-up is enabled (positive contact activation) through the PC output of the control unit. The output can be configured as follows (Configuration table - parameter 106):
 - Stop by de-energisation (output activation during engine operation).
 - Stop by excitation (engine stop pulse; Times table - parameter 408). The operating mode of the enabled output can be set.
4. **Engine start-up.** The start-up output (ARR) is activated during the engine start-up process for a maximum programmed time (Times table - parameter 403), until at least one of the programmed start-up conditions is detected. The possible engine start-up detection conditions are:
 - **Generator voltage** (Configuration table - parameter 102). The engine is considered started when a certain generator voltage is exceeded (Thresholds table - parameter 314).
 - **Alternator voltage** (Configuration table - parameter 103). The engine is considered started when a certain battery charging alternator voltage is exceeded (Thresholds table - parameter 315).
 - **Engine speed** (Configuration table - parameter 104). The engine is considered started when a certain engine speed is exceeded (Thresholds table - parameter 316). To activate engine speed calculation by pulse count of the engine's ring gear, it is necessary to enter the number of teeth on the engine's flywheel ring gear (Thresholds table - parameter 317); if the number of teeth for the flywheel ring gear is zero, the engine speed is calculated via the generator frequency according to the ratio 50 Hz / 1500 rpm, 50 Hz / 3000 rpm or 60 Hz / 1800 rpm (Configuration table - parameter 8).



- **Low Oil Pressure Signal** (Configuration table - parameter 105). Due to its characteristics, it is not advisable to use the low oil pressure signal to detect if the engine is running, but its use is recommended as protection against a restart, as the engine is already running. Exceptions to this engine start-up detection are sensors that have their own power source.

If during the set time no engine start-up is detected, the control unit waits for a period of time (Times table - parameter 401) before attempting start-up again. Once a certain number of start-ups has been exceeded without detecting any start-up condition (Threshold table - parameter 301), the control unit activates the Start-Up Failure alarm.

During engine start-up, the excitation of the battery charging alternator is carried out through the D+ output for a certain period of time (Times table - parameter 406). Once the alternator has been excited, the control unit monitors correct operation of the battery charging alternator. If a battery charging alternator failure is detected, the Alternator Failure alarm is activated (Alarms table - parameters 1010, 1011 and 1012).

5. **Engine stabilization.** Once any start-up condition is detected, the control unit waits for a fixed time for stabilization of the generator signal (Times table - parameter 405) before monitoring the quality of the generator signal.

PRACTICAL EXAMPLE OF A START-UP OPERATION

NOTE:

Before starting the start-up cycle it is advisable to ensure the genset's main circuit breaker is in the off position (OFF).



PREHEATING: The start-up cycle starts when the key is placed in the START position. At the same time, if the engine has a preheating plug, the PR output is activated for the time set (Times table - parameter 402).



START-UP: Once the set time has elapsed the PR output is immediately deactivated and the positive contact PC output is activated and 0.5 seconds after the ARR output until a started engine condition is detected for a maximum set time (Times table - parameter 403). If the maximum set start-up time is exceeded (Times table - parameter 403) without detecting any engine started condition, the control unit waits for a period of time (Times table - parameter 401) before re-initiating the engine start-up. This process is repeated for a set maximum number of times (Thresholds table - parameter 301).



STARTED: Once the started engine is detected, a set waiting time (Times table - parameter 405) begins for the engine to stabilize before activating the genset contactor that provides the electric power.



STABILIZED: After the stabilization time has elapsed, the control unit completes the generator set start-up process.

To interrupt the start-up cycle just press the STOP button.

NOTE

Start-up in an automatic system using a timer, external signal, etc. is carried out following the same process as when starting up manually.



4.1.2 ENGINE STOP

The engine stopping process in automatic mode is carried out as follows:



Cooling the engine. Once it is running in no-load conditions, the engine will continue running for a cooling time (Times table - parameter 407). In certain situations, the control unit alarms can be set (Alarms table - parameters 1003, 1006, 1009, etc.) to perform a stop without engine cooling.

Engine stop. Once the engine cooling time has passed, the control unit sends a command to the PC output, depending on the setting that has been programmed (Configuration table - parameter 106). Any combination of the following options can be chosen as an engine stop condition:

- **Generator voltage** (Configuration table - parameter 102). The engine is considered stopped when the generator voltage is below the start-up threshold (Thresholds table - parameter 314).
- **Alternator voltage** (Configuration parameter 103). The engine is considered stopped when the battery charging alternator voltage is below the start-up threshold (Thresholds table - parameter 315).
- **Engine speed** (Configuration table - parameter 104). The engine is considered stopped when the engine speed is below the start-up threshold (Thresholds table - parameter 316). To activate the engine speed calculation via the pulse count of the engine flywheel ring, it is necessary to enter the number of teeth on the engine's flywheel ring gear (Thresholds table - parameter 317); if the number of teeth for the flywheel ring gear is zero, the engine speed is calculated via the generator frequency according to the ratio 50 Hz / 1500 rpm, 50 Hz / 3000 rpm or 60 Hz / 1800 rpm (Configuration table - parameter 108).
- **Low Oil Pressure Signal** (Configuration table - parameter 105). The low oil pressure condition is used for detecting a stop, by which the engine is considered stopped when it is detected that the sensor is closed. Exceptions to this engine stop detection are engines that have sensors with their own power source.

To confirm the engine has stopped, all the programmed stop conditions must be detected for a set period of time (Alarms table - parameter 1071). If after 90 seconds an engine running condition continues to be detected, the Stop Failure alarm is triggered.

PRACTICAL EXAMPLE OF A STOP OPERATION

NOTE

Before beginning the stopping cycle, it is advisable to ensure the genset circuit breaker is in the off position (OFF).

The genset can be stopped in various ways:

- 1. Manual:** Pressing the STOP button once. To perform a stop with a cooling cycle.
- 2. Manual:** Pressing the STOP button twice. To perform a stop without a cooling cycle.
3. Turning the control unit's **activation key** to the "O" position. To perform a stop without a cooling cycle.
- 4. Automatic:** After disabling the start-up condition producing a cooling stop.

COOLING: Press the STOP button once, the genset contactor is deactivated and the stop cycle with engine cooling begins.

STOP: After the cooling time has ended (Times table - parameter 407), the PC output is disabled or enabled according to the type of engine to perform the stop (Configuration table - parameter 106).

STOPPED: The M7T control unit ends the engine stop process once all the engine started conditions are no longer detected. If after a period of time (Alarms table - parameter 1071) any engine started conditions are still detected, the STOP FAILURE alarm will be activated.

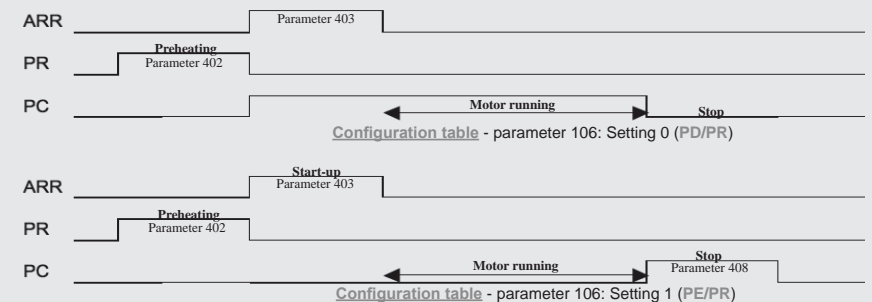

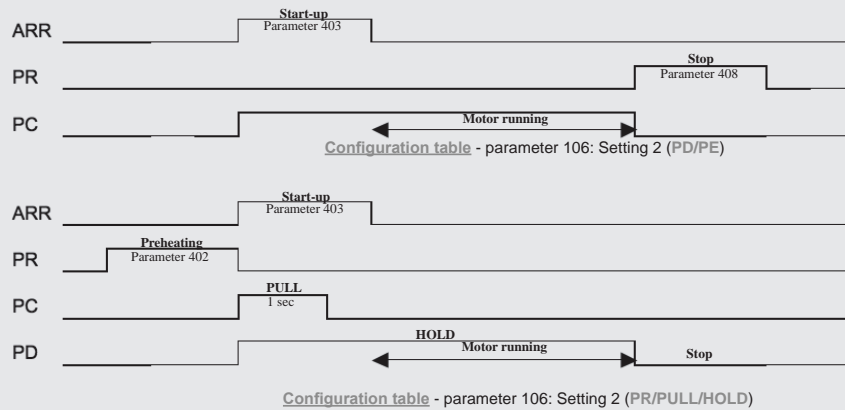

4.1.3 BATTERY CHARGING ALTERNATOR

The M7T control unit excites the battery charging alternator with a configurable pulse time (Times table - parameter 406) during the engine start-up process through the D+ output. At the end of the pulse, the control unit tests the voltage generated by the battery charging alternator.

The voltage generated by the battery charging alternator can be used as an engine start-up condition (Configuration table - parameter 103). For this purpose, the control unit waits to measure voltage, via the D+ analogue input, which is above an alternator voltage detection threshold (Thresholds table - parameter 315).

The M7T control unit can be configured to trigger an Alternator Voltage alarm (Alarms table - parameter 1010 to 1012) if a low voltage level is detected from the battery charging alternator through the D+ analogue input.

4.2 PROGRAMMABLE OUTPUTS

The M7T control unit has 3 programmable function outputs:

- **Programmable output 1:** transistor output 2A PD (Configuration table - parameter 122). Any function that has been assigned to Programmable output 1 will be disabled when the engine start-up configuration is programmed in PULL/HOLD mode (Configuration table - parameter 106 value 3). In this mode, the programmable output 1 is used exclusively as an engine start-up HOLD signal.
- **Programmable output 2:** MN relay output (Configuration table - parameter 123). By default, the relay programmable output 2 is associated with the electronic protection function.
- **Programmable output 3:** transistor output 2A CON (Configuration table - parameter 124). By default, the relay programmable output 3 is associated with the generator set contactor function.

4.2.1 ELECTRONIC PROTECTION

The electronic protection function of the M7T control unit can be activated by associating its operation to any of the 3 free programmable outputs (1, 2 or 3) using the control unit programming (Configuration table, parameters 122 to 124 value 1). By default, the (MN) relay programmable output 2 is associated with the electronic protection function (Configuration table - parameter 123).

The electronic protection is a feature that is used to activate a controller output in the event of an alarm that causes the engine to stop; it deactivates the generator set circuit breaker via a trip coil. The output assigned to this function will remain active as long as there is an active alarm causing the engine to stop and pending notification.

4.2.2 FUEL TRANSFER PUMP

The fuel transfer pump function of the M7T control unit can be activated by associating its operation to any of the 3 free programmable outputs (1, 2 or 3) using the control unit programming (Configuration table, parameters 122 to 124 value 3). Once the fuel transfer pump option is activated, the control unit will activate the programmed output so it will be automatically controlled according to the minimum activation threshold (Thresholds table - parameter 326) and the maximum deactivation threshold (Thresholds table - parameter 327), under and over which the output will be activated or deactivated, respectively.



Calibration of the gauge: For correct fuel level measurements (required for managing the fuel transfer pump and fuel level alarm) a calibration of the tank gauge should be performed. This requires access to the minimum and maximum gauge level parameters (Measurements table - parameters 202 and 203) at the bottom and top positions of the gauge, respectively. A non-linear response of the gauge can also be programmed (Measurement table - parameter 206).

4.2.3 DUMMY LOAD

The dummy load function of the M7T control unit can be activated by associating any of the 3 free programmable outputs (1, 2, or 3) using the control unit programming (Configuration table, parameters 122 to 124 value 3).

This function is used to activate a load bank that is independent from the installation load, to prevent no-load operation or operation with low engine load thresholds, thereby preventing excess oil consumption.

The M7T control unit activates the output configured in dummy load mode when generator set power consumption is detected to be lower than a programmed threshold (Thresholds table - parameter 328). The output configured as the programmed dummy load output is deactivated when genset power consumption is detected to be higher than the programmed threshold (Thresholds table - parameter 329). As a condition for enabling the dummy load output, the generator set must have the genset contactor active.

4.2.4 ENGINE STARTED SIGNAL

The engine started function of the M7T control unit can be activated by associating its operation to any of the 3 free programmable outputs (1, 2 or 3) using the control unit programming (Configuration table, parameters 122 to 124 value 4).

The started engine output mode of the M7T control unit is activated when any started engine condition is detected and remains active while the engine is running. The started engine output is deactivated as soon as the engine stopping process begins; said process includes the engine cooling interval (Times table - parameter 407) during the stopping process.

4.2.5 GENSET BREAKER

The genset contactor function of the M7T control unit can be activated by associating its operation to any of the 3 free outputs (1, 2 or 3) using the control unit programming (Configuration table, parameters 122 to 124 value 5).

In the M7T control unit, the output programmed in genset contactor mode opens and closes the genset contactor that provides the installation with power. The genset contactor is activated and programmed to stabilize the electrical signal for a period of time after the detection of engine started (Times table - parameter 404).

4.2.6 INPUT 1

The genset input 1 function of the M7T control unit can be activated by associating its operation to any of the 3 free outputs (1, 2 or 3) using the control unit programming (Configuration table, parameters 122 to 124 value 6).

The M7T control unit output configured in input 1 mode is activated when input 1 activation is detected. It is deactivated when the period of time that has been programmed has elapsed (Times table - parameter 404); if the programmed time is 0, the output will deactivate when input 1 is deactivated.

4.3 SINGLE TRANSFORMER

When the electronic generator set is configured as a single transformer (Configuration table - parameter 125), the control unit functions with a single current measurement channel. To do so, during calculation of generator set power, it interprets that the generator set load for each phase is balanced, so the total power supplied is calculated by multiplying the current measurement in the first channel by the number of phases in the generator set.







4.4 MOTORPUMP MODE

Configuration in motor pump mode (Configuration table - parameter 119) allows the control unit to work in non-power generation mode, controlling only the functioning of the engine. To do so, only the engine signals and alarms are taken into account. For this application, the use of a pickup sensor for counting pulses of the engine crown wheel is recommended, performing the engine speed calculation for detecting the starting, stopping and speed of the engine.

4.5 TIMED START-UP

It is possible to program the generator set operating time by holding down the key  while the engine is running and the control unit is in manual operation mode; the programmed operation time is displayed. The operation time increases at intervals of 5 minutes while holding down the key up to a maximum of 18 hours. When the programmed time has expired, a stop is carried out with engine cooling.

To cancel the programmed operation time, press the key . The stop engine operation of a genset with timed start-up is:

- **1st press of the key** : cancellation of timed genset operation.
- **2nd press of the key** : start engine cooling stop (genset contactor off); automatic engine stop after the cooling time has elapsed (Times table - parameter 407).
- **3rd press of the key** : immediate motion stop; cancel the engine cooling time (Times table - parameter 407).



5. INPUTS AND OUTPUTS

The M7T control unit's digital inputs, both those with a specific purpose as well as those which are programmable, have an associated debounce time (Times table - parameters 411 to 418) which requires the setting of the input to be stable over a time interval to validate its status. Also, the polarity of all the M7T control unit's inputs can be configured to be active with contact closed to earth or be inactive with contact closed to earth (Configuration table - parameters 111 to 118).

: The status of the M7T control unit's inputs and outputs can be monitored from the maintenance menu.











Fig.1
Outputs











Fig.2
Inputs



Detection of an **active input** is indicated by the following symbols:

	Fuel reserve
	Low oil pressure
	High temperature
	Water level
	External start-up
	Emergency stop
	Programmable input 1
	Programmable input 2

Detection of an **active output** is indicated by the following symbols:

	Engine start-up
	Engine preheating
	Positive contact (IGNITION)
	Alarm active
	Programmable output 3
	Battery charging alternator
	Programmable output 1
	Programmable output 2

By pressing the up or down scroll keys it is possible to display the analogue inputs.



Fig.3
Fuel level



Fig.4
Engine temperature







Fig.5
Oil pressure



Fig.6
Optional: Control unit temperature sensor

The value of the resistive analogue inputs is shown in ohms and the ambient temperature sensor input (optional) is shown in °C. The various inputs displayed are:

	Fuel level
	Oil pressure
	Engine temperature
	Ambient temperature (optional)

5.1 DIGITAL INPUTS

5.1.1. SPECIFIC FUNCTION INPUTS

The M7T control unit has 6 digital inputs with functions that are set by default to perform a specific function. In addition, all inputs except Emergency Stop (PEM) can be programmed to implement any of the functions from the Programmable function inputs section.

External start-up signal (AE)

This function is only managed in automatic mode of the M7T control unit.

The input configured as the external start-up forces generator set start-up if it is in automatic mode.

Each of the following fixed-purpose inputs is associated with the activation of a generator set alarm:

High temperature (ATA/HTC)

Digital signal notifying the control unit that an alarm has been generated due to high engine temperature (Alarms table - parameters 1001 to 1003).

Low oil pressure (BPA/LOP)

Digital signal notifying the control unit that an alarm has been generated due to low oil pressure (Alarms table - parameters 1004 to 1006).

Coolant level (NA/CL)

Digital signal notifying the control unit that an alarm has been generated due to low coolant level (Alarms table - parameters 1016 to 1018).

Emergency stop (PEM/EMS)

Digital signal notifying the control unit that an immediate stop of the engine must be performed without cooling. The emergency stop input shuts down the engine's control electronics, thereby forcing the engine to stop physically.

NOTE

The emergency stop input shuts down the activation of the M7T control unit's PC and PD outputs. If the engines being used require stopping via electromagnet activation (Configuration table - parameter 106), the control unit's emergency stop input must be wired to the negative pole of the generator set battery and configure a programmable function input as the stop push button.

Fuel reserve (RC/FR)

Digital signal notifying the control unit that an alarm has been generated due to the fuel reserve (Alarms table - parameters 1019 to 1021).



5.1.2. PROGRAMMABLE FUNCTION INPUTS

The M7T control unit allows you to program the analogue inputs P and T, and any digital input except Emergency Stop (PEM) to have one of the following behaviours (Configuration table - parameter 120, 121 or 126-132).

Forced operation

This function is only managed in automatic mode of the M7T control unit. The input configured as forced operation is compliant with fire prevention regulations to the effect that under no circumstances should operation of the genset be stopped (except for overspeed alarms and emergency stop. It is possible to configure 3 modes of forced operation (Configuration table, parameter 110):

- **0: Forced operation not enabled.** The process of forced operation is not managed despite having an associated programmable input.
- **1: External start-up signal (AE).** When activating the forced operation input, it is necessary to wait for the external start input to be activated in order to start-up the genset. To stop the genset it is not sufficient that the start condition disappears, but the input associated with the forced operation must be disabled.
- **2: Starting due to forced operation.** Before activating the forced operation input, the genset starts immediately without the need to wait for any other start condition to occur. To stop the genset, it is necessary to switch to manual operating mode and in this mode perform the stop using the control unit keyboard.

Programmable alarms 1 and 2

There are 2 free programmable alarms that can be associated with any of the programmable alarms used to provide the controller with additional alarms that can be configured (Alarms table - parameters 1079 to 1084).

Parameter set selection

There is a set of additional parameters that can be enabled by either of the programmable inputs. Activating the parameter set selection input enables the settings used by the control unit to operate (Selector table parameters).

Emergency stop

For engines that need to be stopped via electromagnet excitation, there is an option of having an input to activate an additional emergency stop alarm (Configuration table - parameter 106). Contrary to the control unit's PEM input, the programmed configurable input, such as the stop push button, does not physically disable the PC engine control output and the PD programmable output, thereby allowing stopping of engines configured as excitation stops (Configuration table - parameter 106 setting 1).

Confirmation of contactor

Programming a programmable input to confirm a generator set contactor ensures correct activation of the contactor if the generator set is started up and contactor deactivation when the generator set is stopped or in a cooling off period. The generator set contactor confirmation input is associated with detection of the generator set contactor failure alarm (Alarms table - parameters 1091 to 1093).

Control of lighting outputs

The programming of an input to individually control any of the 4 lighting outputs (Configuration table - parameter 120, 121 or 126-132 with values 10 to 13) inhibits the switching on of the output associated with the light.

Control of all lighting outputs

The programming of an input to control all of the lighting outputs (Configuration table - parameter 120, 121 or 126-132 with values 10 to 14) inhibits the switching on of the all the outputs associated with the lights.



5.2 ANALOGUE INPUTS

The M7T control unit has 3 analogue inputs to measure the engine operation values. These analogue inputs characterize the operation of the engine to display its status and produce alarms if necessary. By default, the alarms produced by the analogue inputs do not stop the control unit (engine warnings), but can be configured to perform this stop with or without cooling.

The M7T control unit performs a continuous check on the presence of the analogue sensors installed, with the readings taken appearing on the sensors installed in the generator set.



Fuel level input (NC/FL)

The fuel level analogue input indicates the amount of fuel remaining in the tank. To adjust its operation (Section 4.2.2), it has to be calibrated by adjusting the maximum fuel tank setting (Measurements table - parameter 203) and the minimum fuel tank setting (Measurements table - parameter 202).

It is also possible to set a minimum fuel threshold in the tank (Thresholds table - parameter 318) to cause an alarm warning (Alarms table - parameters 1055 to 1057) when the fuel level is detected to be below this limit.

When one of the configurable outputs of the control unit is programmed to manage the fuel transfer pump, if the fuel level is detected to be below a lower limit (Thresholds table - parameter 326) this will start up the fuel transfer pump to provide the tank with fuel. Deactivation of the fuel transfer pump occurs when the fuel level is detected to be above the programmable threshold (Thresholds table - parameter 327).



Oil pressure input (P)

The oil pressure analogue input allows the engine oil pressure value to be monitored. The response curve of the pressure sensor installed in the generator set can be programmed in the control unit. A minimum oil pressure limit can be established by programming a threshold (Thresholds table - parameter 319) to trigger an engine alert (Alarms table - parameters 1052 to 1054) when the pressure is detected to be below this limit.

Analogue input P can also be configured to perform any programmable function (Configuration table - parameter 131). Its default operation is as an analogue input (Configuration table - parameter 130 value 0).



Engine input temperature (T)

The engine temperature analogue input allows the engine water temperature value to be monitored. The response curve of the coolant temperature sensor installed in the generator set can be programmed in the control unit. A maximum engine temperature limit can be established by programming a threshold (Thresholds table - parameter 320) to trigger an engine alert (Alarms table - parameters 1049 to 1051) when the temperature is detected to be above this limit.

Analog input T can also be configured to perform any programmable function (Configuration table - parameter 132). Its default operation is as an analogue input (Configuration table - parameter 132 value 0).



Alternator voltage input (D+)

The alternator voltage analogue input allows the voltage generated by the battery charging alternator to be monitored. This input is used to diagnose possible malfunction of the alternator if it detects low voltage while the engine is running; under these conditions, a battery alternator alarm (Alarms table - parameters 1010 to 1012) is generated.

Likewise, this voltage can be programmed to detect generator set start-up conditions (Configuration table - parameter 103) by using an alternator voltage threshold for a started engine (Thresholds table - parameter 315).



5.3 PICKUP INPUT (PKC1/PKC2)

The control unit's PICKUP input calculates the engine rotation speed in revolutions per minute (rpm) by controlling engine ring pulses. To calculate the rotation speed, it is necessary to enter the number of teeth on the engine flywheel ring gear (Thresholds table - parameter 317). If zero is entered as the number of teeth for the flywheel ring gear parameter, the control unit is configured not to calculate engine speed via the engine flywheel ring pulse counter but to calculate the rotational speed from the frequency generated by the genset according to the ratio 50 Hz/1500 rpm, 50 Hz/3000 rpm or 60 Hz/1800 rpm or 60 Hz/3600 rpm (Configuration table - parameter 108). The M7T control unit can be configured to produce an overspeed alarm (Alarms table - parameters 1022 to 1024) as well as an underspeed alarm (Alarms table - parameters 1025 to 1027) depending on the mechanical speed provided by the pickup.

5.4 PROGRAMMED DIGITAL OUTPUTS

The M7T control unit has 5 specific-purpose outputs (3 power outputs and 2 digital outputs). The functioning of these outputs is preset but can be configured.

Preheating output (PR). Power Output.

The preheating output (PR) of the M7T control unit is an output connected to a high power shortable driver (40 A) that regulates the heating process of the engine's spark plugs during the start-up process. The activation time of the preheating output can be set (Times table - parameter 402). The preheating output can also be used to control stopping via excitation of engines that use this type of stop (Configuration table - parameter 106).

Engine start-up output (ARR). Power output.

The engine start-up output (ARR) of the M7T control unit is an output connected to a high power shortable driver (40 A) that activates the starter. The engine start-up output remains active until a programmed engine running condition is detected (Configuration table - parameters 102 to 105) for a programmable maximum time (Times table - parameter 403).

Engine stop output (PC). Power Output

The engine stop output (PC) of the M7T control unit is an output connected to a high power shortable driver (40 A) that controls shut-down of the engine and is limited by the control unit's PEM input. The engine stop output can be configured so that it controls engines with 3 start-up/stop modes (Configuration table - parameter 106):

- **Stop via de-energisation.** The engine stop output configured as a stop via de-energisation is activated 500 minutes after the preheating output has been deactivated, and it is deactivated when the engine stop command has been given.
- **Stop by excitation.** The engine stop output configured as a stop by excitation is activated for a programmable time interval (Times table - parameter 408) when the engine stop command has been given. In this configuration, the control unit's PEM input for emergency stop must be wired to the negative pole of the battery and the generator set stop button must be wired to a configurable programmed input as a stop push button (Configuration table - parameter 120 or 121 setting 5).
- **Stop by excitation/de-energisation.** The engine stop output configured as a stop by excitation/de-energisation is activated 500 minutes after the preheating output has been deactivated, and is deactivated when the engine stop command has been given. This output is used to enable the engine sensors, with the preheating output involved in performing the engine stop via the process of stopping by excitation.
- **PULL/HOLD engine control.** The engine start control set in PULL/HOLD mode uses the PC output (40 A) as a PULL signal that is activated for a fixed time of 1 second during start-up. The configurable PD output (2 A) is used as a HOLD signal that remains active while the engine is running. The M7T control unit, configured as PULL/HOLD control (Configuration table - parameter 106 setting 3) disables any function that may have been programmed in the configurable PD output (Configuration table - parameter 122).

Excitation output of the battery charge alternator (D+). Digital output.

The D+ output of the M7T control unit is responsible for exciting the battery charging alternator during the start-up process. This output is configured to provide a start pulse that has a programmable time interval (Times table - parameter 406).



Alarm output (AL). Digital output.

The alarm output (AL) is in charge of communicating the different statuses of the M7T control unit. The AL output simultaneously activates Reset key LED flashing and the buzzer of the M7T control unit. This output monitors the following statuses of the M7T control unit:





- **External start-up of the control unit.** If control unit start-up is ordered through the AE input, the control unit's alarm output (AL) is activated for a time period that can be configured (Times table - parameter 409) before engine start-up. If a start-up delay is not programmed (Times table - parameter 409 setting 0), M7T control unit alarm signal activation will overlap engine start-up for a fixed period of 5 seconds.
- **Control unit errors.** Given an error which is active or pending notification by the user, control unit alarm output is activated for a maximum programmable time (Times table - parameter 410). When the Reset key is pressed by the user, the AL output is disabled. The errors that activate the AL output are both alarms that cause the engine to stop and warnings that do not cause the engine to stop.

5.5 PROGRAMMABLE OUTPUTS

The M7T control unit has 3 programmable outputs that can be configured to indicate certain statuses (Configuration table - parameters 122 to 124). The various types of outputs that correspond to the programmable outputs are as follows:

- Sal1 (PD): driver digital output 2 A. Interconnected through the emergency stop input (PEM) of the control unit.
- Sal2 (MC/MNA/MNC): relay output 2 statuses.
- Sal3 (CON): driver digital output 2 A.

The possible configurations that are permitted with the programmable outputs are:

-	Output inhibited: The programmable outputs configured as inhibited output do not respond to any action or state as they are permanently disabled.
	Electronic protection (see Section 4.2.1)
	Transfer pump (see Section 4.2.2)
	Dummy load (see Section 4.2.3)
	Started engine signal (see Section 4.2.4)
	Generator set contactor (see Section 4.2.5)

5.6 LIGHTING TOWER OUTPUTS

The M7T control unit includes 4 outputs designed to control the lights of a lighting tower. It has PNP-type outputs that are capable of providing 1A and a voltage equal to the + BAT voltage. The 4 outputs are called S1, S2, S3 and S4.

The lighting control outputs have some special functions:

- **Switching on sequence.** Each output can be associated a switching on delay time (Times table - parameter 420 to 423) from the moment of activation of the genset contactor to each output in order to avoid switching on the lights simultaneously. By properly configuring these delays, an output switching on sequence can be obtained that avoids overloading the genset as a result of switching on the outputs simultaneously. In addition, there is a parameter (Measurements table - parameter 212) that allows a delay between switching on each light, allowing a lag to be created between them. The switching on delay time of any light (Times table - parameters 420 to 423) overlaps the delay time between switching on each light (Measurements table - parameter 212).



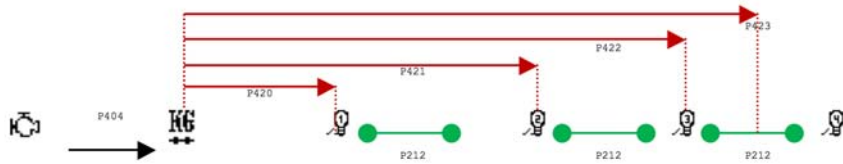

Example diagram of overlap of conditions when there is a delay in switching on lights: lights 2 and 3 are switched on after delay from the moment of activation of the genset contactor (parameters 421 and 422 more restrictive conditions) and light 4 is switched on after delay between switching on each light (parameter 212 more restrictive condition).

NOTE

Whether or not there is a genset contactor in the electrical panel in series with the outputs, and whether or not a programmable output is configured as a genset contactor, the genset breaker activation delay (Times table - parameter 404) will always be respected in addition to the output delay. The genset contactor time can be set to 0.

- **Shutdown sequence.** As with switching on, during shutdown a delay time can be associated with the shutdown of each light bulb (Times table - parameter 424 to 427); this will be counted from the moment of the stop command. By properly configuring these delays a shutdown sequence of the outputs can be obtained that avoids sudden load changes in the case of a shutdown due to cooling.

NOTE

If there is a genset contactor in series with the outputs in the electrical panel, there is a new parameter that delays the switching off of the genset contactor (Times table - parameter 428) that must be greater than the highest output delay so that the shutdown is carried out correctly and the contactor is the last to be switched off.

- **Lighting cooling time (restrike).** To account for the cooling time required for some lights, a cooling time parameter associated with each output has been added before attempting a restart (Times table - parameter 429 to 432). The cooling time will be considered a delay in the activation of an output and will be added upon shutdown.

NOTE

If you do not want to respect the cooling time, you can turn off the control unit completely (key in the OFF position) and proceed with a new switch on and start-up.

- **Detecting dead light bulbs.** If the control unit has current transformers to measure the current consumption of the outputs, lighting faults can be detected as a result of lower than expected consumption (Measurements table - parameter 207 to 210). If a fault is detected during the switching on or shutdown sequence, the control unit will be able to identify which output has generated the below-expectation consumption. In cases where the fault is detected outwith the switching on or shutdown sequence, the dead light bulb alarm will be signalled without specifying at which output the fault has occurred.

NOTE

Current consumption for fault detection is deactivated by default as it depends on the type of lamp installed.

- **Control of outputs by programmable input.** It is possible to configure the control unit's programmable inputs to control the output of the lighting tower (Configuration table - parameter 120 and 121 values 10 to 13). Control functions have been added for each output separately; it is possible to control up to two outputs, one for each input.



6. LIST OF ALARMS









The list of alarms and active warnings of the M7T control unit can be classified as follows (according to the MANUFACTURER'S DEFAULT PROGRAMMING).

6.1 ENGINE ALARMS

Description			Type	Action
E01	High water temperature		Alarm	Engine stops immediately without cooling
E02	Low oil pressure		Alarm	Engine stops immediately without cooling
E03	Emergency Stop		Alarm	Engine stops immediately without cooling
E04	Battery charging alternator failure (with engine running)		Warning	Engine doesn't stop
E05	Start-up failure			
E06	Low water level		Alarm	Engine stops immediately without cooling
E07	Fuel reserve		Warning	Engine doesn't stop
E08	Overspeed		Alarm	Engine stops immediately without cooling
E09	Underspeed		Alarm	Engine stops with cooling
E16	Low battery voltage		Warning	Engine doesn't stop
E17	High water temperature by sensor		Warning	Engine doesn't stop
E18	Low oil pressure by sensor		Warning	Engine doesn't stop
E19	Low fuel level by sensor		Warning	Engine doesn't stop
E23	Unexpected stop			
E24	Stop failure			
E32	Communication engine (M7J control unit)		Warning	Engine doesn't stop
E34	Generator set maintenance		Warning	Engine doesn't stop





6.2 GENERATOR ALARMS

Description	Type	Action
E10 Overload 	Alarm	Engine stops with cooling
E12 Genset overvoltage threshold 	Alarm	Engine stops immediately without cooling
E13 Genset overfrequency threshold 	Alarm	Engine stops immediately without cooling
E20 Short-circuit 	Alarm	Engine stops with cooling
E21 Genset undervoltage threshold 	Alarm	Engine stops with cooling
E22 Genset underfrequency threshold 	Alarm	Engine stops with cooling
E26 Genset signal failure 	Warning	Engine stops with cooling
E31 Generator set contactor (only programmable input to verify genset contactor) 	Warning	

6.3 PROGRAMMABLE INPUT ALARMS

The M7T control unit has 2 programmable alarms that can be associated with generator set inputs. These alarms can be associated with either of the control unit's 2 programmable inputs (Configuration table - parameters 120 and 121).

Description	Type	Action
E27 Programmable alarm 1 		Configurable
E28 Programmable alarm 2 		Configurable

All alarms except those which are non-programmable, can be configured as follows:

To be activated:

1. Never
2. Always
3. During the start-up of the engine
4. From detection that the engine has started
5. From the rated condition of the engine

To perform one of the following actions:

6. Not perform any actions (warning)
7. Stop the engine with cooling of the engine
8. Perform an immediate stop of the engine

The default configuration of each of the alarms will be highlighted.

6.4 LIST OF ALARMS

High Water Temperature

The M7T control unit's high water temperature alarm is associated with the digital input specifically provided for high water temperature (ATA). The status of this input must be validated during a time interval (Times table - parameter 413) for stabilisation (debounce) before generating the high water temperature alarm.

It can be configured as normally open or normally closed (Configuration table - parameter 113).

Detection of the high water temperature alarm is set by default (Alarms table - parameter 1001) to be active: Always.

The high water temperature alarm can be associated with a time (Alarms table - parameter 1002) to delay the moment at which the alarm begins to check the alarm conditions.

The high water temperature alarm is set by default (Alarms table - parameter 1003) to stop the engine immediately.



Low oil pressure

The M7T control unit's low oil pressure alarm is associated with the digital input specifically provided for low oil pressure (BPA). The status of this input must be validated during a time interval (Times table - parameter 412) for stabilisation (debounce) before generating the low oil pressure alarm.

It can be configured as normally open or normally closed (Configuration table - parameter 112).

Detection of the low oil pressure alarm is set by default (Alarms table - parameter 1004) to be active: From detection that the engine has started.

The low oil pressure alarm can be associated with a time (Alarms table - parameter 1005) to delay the moment at which the alarm begins to check the alarm conditions.

The low oil pressure alarm is set by default (Alarms table - parameter 1006) to stop the engine immediately.

Emergency stop

The M7T control unit's emergency stop alarm is associated with the digital input specifically provided for emergency stops (PEM) or the configurable function input programmed as the stop push button.

The PEM input can be configured as normally open or normally closed (Configuration table - parameter 115). The PEM input disables the PC and PD power outputs, thereby ensuring that engines configured to stop by excitation or PULL/HOLD stop properly (Configuration table - parameter 106 settings 0 and 3), regardless of control unit operations. In engines configured to stop by excitation (Configuration table - parameter 106 setting 1), the PEM input should be connected to earth and the generator set stop push button should be wired to a configurable input that is programmed as a stop push button (Configuration table - parameter 120 or 121 setting 5).

The emergency stop alarm always executes the engine shutdown without cooling. It is not possible with this action to associate any delay time, set to engage immediately after detecting the emergency stop input (PEM).

Battery charging alternator failure

The M7T control unit's battery charging failure alarm is associated with the analogue input that reads the battery charging alternator voltage (D+). When the engine is running, the voltage measured via said input must exceed the voltage threshold for detecting that the engine has started (Thresholds table - parameter 315); otherwise, this battery alternator failure alarm will be activated.

Detection of the battery alternator failure is set by default (Alarms table - parameter 1010) to be activated: From detection that the engine has started.

The battery alternator failure alarm can be associated with a debounce time (Alarms table - parameter 1011) during which the voltage measured via the D+ input must remain below the started engine detection threshold as a condition to activate the battery alternator failure alarm.

The battery alternator failure alarm is set by default (Alarms table - parameter 1012) not to perform any action (warning).

Start-up failure

The M7T control unit's start-up failure alarm is generated if the number of consecutive retries and failures (Threshold table - parameter 301) is exceeded during engine start-up. There is a programmable delay between each start-up attempt (Times table - parameter 401). Once the alarm has been generated the control unit waits for the notification by the user before retrying the engine start-up process.

Low water level

The M7T control unit's low water level alarm is associated with the digital input specifically provided for low water level (NA). The status of this input must be validated during a time interval (Times table - parameter 414) for stabilisation (debounce) before generating the low water level alarm.

It can be configured as normally open or normally closed (Configuration table - parameter 114).

Detection of the low water level alarm is set by default (Alarms table - parameter 1016) to be active Always.



The low water level alarm can be associated with a time (Alarms table - parameter 1017) to delay the moment when the alarm begins to check the alarm conditions.

The low water level alarm is set by default (Alarms table - parameter 1018) to stop the engine immediately if it is not already stopped.

Fuel reserve

The M7T control unit's fuel reserve alarm is associated with the digital input specifically provided for the fuel reserve (RC). The status of this input must be validated during a time interval (Times table - parameter 411) for stabilisation (debounce) before generating the fuel reserve alarm.

It can be configured as normally open or normally closed (Configuration table - parameter 111).

Detection of the fuel reserve alarm is set by default (Alarms table - parameter 1019) to be active Always.

The fuel reserve alarm can be associated with a time (Alarms table - parameter 1020) to delay the moment when the alarm begins to check the alarm conditions.

The fuel reserve alarm is set by default (Alarms table - parameter 1021) not to perform any action (warning).

Overspeed

The M7T control unit's overspeed alarm is associated with the measurement of the engine flywheel ring gear's rotation speed. This measurement is performed via the control unit's pickup input. Alarm management depends on a parameter setting for the number of teeth on the flywheel ring gear (Thresholds table - parameter 317) that is not zero.

Detection of the overspeed alarm is set by default (Alarms table - parameter 1022) to be activated: From the rated condition of the engine.

The overspeed alarm can be associated with a debounce time (Alarms table - parameter 1023) during which ring gear rotation speed must be kept above the maximum rotation speed limit (Thresholds table - parameter 311).

The overspeed alarm is set by default (Alarms table - parameter 1024) to stop the engine immediately.

Underspeed

The M7T control unit's underspeed alarm is associated with the measurement of the engine flywheel ring gear's rotation speed. This measurement is performed via the control unit's pickup input. Alarm management depends on a parameter setting for the number of teeth on the flywheel ring gear (Thresholds table - parameter 317) that is not zero.

Detection of the underspeed alarm is set by default (Alarms table - parameter 1025) to be activated: From the rated condition of the engine.

An underspeed alarm can be associated with a debounce time (Alarms table - parameter 1026) during which it must be kept below the minimum threshold setting (Thresholds table - parameter 312).

The underspeed alarm is set by default (Alarms table - parameter 1027) to perform an engine stop with cooling.

Overload

The M7T control unit's overload alarm is associated with a measurement of the RMS current in any phase that exceeds the maximum programmed overload limit (Thresholds table - parameter 307) but that is lower than the maximum short circuit limit (Thresholds table - parameter 308).

The phases that are checked to detect the overload alarm are selected according to the configuration of the installation phases (Configuration table - parameter 101):

1. In a single phase configuration phase 1 is tested.
2. In a two-phase configuration, phases 1 and 2 are tested.
3. In a three-phase configuration with neutral or three-phase without neutral phases 1, 2 and 3 are tested.

Detection of the overload alarm is set by default (Alarms table - parameter 1028) to be activated: From the rated condition of the engine.

The overload alarm can be associated with a debounce time (Alarms table - parameter 1029) during which the current measured must remain above the maximum programmed limit (Thresholds table - parameter 307).

The overload alarm is set by default (Alarms table - parameter 1030) to perform engine stop with cooling.



Genset overvoltage threshold

The M7T control unit's maximum genset voltage alarm is associated with an RMS voltage measurement that exceeds the maximum voltage threshold setting (Thresholds table - parameter 302).

The phases that are checked to detect the maximum genset voltage alarm are selected according to the configuration of the installation phases (Configuration table - parameter 101):

1. In a single phase configuration, phase 1 voltage is tested.
2. In a two-phase configuration, the voltages in phases 1 and 2 are tested.
3. In a three-phase configuration with neutral or three-phase without neutral, the voltages in phases 1, 2 and 3 are tested.

Detection of the genset maximum voltage alarm is set by default (Alarms table - parameter 1034) to be activated: From the rated condition of the engine.

The maximum genset voltage alarm can be associated with a debounce time (Alarms table - parameter 1035) during which the voltage must be kept above the maximum threshold setting (Thresholds table - parameter 302).

The maximum genset voltage alarm is set by default (Alarms table - parameter 1036) to stop the engine immediately.



Genset overfrequency threshold

The M7T control unit's maximum genset frequency alarm is associated with a frequency generated by the genset that exceeds the maximum frequency threshold setting (Thresholds table - parameter 305).

The measurement of genset frequency is carried out on the first phase. If in that phase no signal is detected, the frequency measurement is then carried out on the second phase. Likewise, if in that phase no signal is detected either, the frequency measurement is then carried out on the third phase.

Detection of the genset's maximum frequency alarm is set by default (Alarms table - parameter 1037) to be activated: From the rated condition of the engine.

The maximum genset frequency alarm can be associated with a debounce time (Alarms table - parameter 1038) during which the frequency must be kept above the maximum threshold setting (Thresholds table - parameter 305).

The maximum genset frequency alarm is set by default (Alarms table - parameter 1039) to stop the engine immediately.



Low battery voltage

The M7T control unit's low battery voltage alarm is activated when the battery voltage measured falls below a threshold setting (Thresholds table - parameter 313).

Detection of the low battery voltage alarm is set by default (Alarms table - parameter 1046) to be activated: Always.

The low battery voltage alarm can be associated with a debounce time (Alarms table - parameter 1047) during which the detected battery voltage must be below the threshold setting (Thresholds table - parameter 313).

The low battery voltage alarm is set by default (Alarms table - parameter 1048) not to perform any action (warning).



High Water Temperature Sensor

The M7T control unit's high water temperature sensor alarm is associated with the analogue input for the water temperature (T). The high water temperature sensor alarm is activated when the temperature detected is higher than the threshold setting (Thresholds table - parameter 320).

Detection of the high water temperature sensor alarm is set by default (Alarms table - parameter 1049) to be active: Always.

The high water temperature sensor alarm can be associated with a debounce time (Alarms table - parameter 1050) during which the detected water temperature must be above the threshold setting (Thresholds table - parameter 320).



The high water temperature sensor alarm is set by default (Alarms table - parameter 1051) not to perform any action (warning).

Low oil pressure by sensor

The M7T control unit's low oil pressure sensor alarm is associated with the analogue input for the oil pressure (P). The low oil pressure sensor alarm is activated when the pressure detected is lower than the threshold setting (Thresholds table - parameter 319).

Detection of the low oil pressure sensor alarm is set by default (Alarms table - parameter 1052) to be active: From detection that the engine has started.

The low oil pressure sensor alarm can be associated with a debounce time (Alarms table - parameter 1053) during which the oil pressure detected must be below the threshold setting (Thresholds table - parameter 319).

The low oil pressure sensor alarm is set by default (Alarms table - parameter 1054) not to perform any action (warning).

Low fuel level by sensor

The M7T control unit's low fuel level sensor alarm is associated with the analogue input for the fuel level (NC). The low fuel level sensor alarm is activated when the fuel level detected is lower than the threshold setting (Thresholds table - parameter 318).

Detection of the low fuel level sensor alarm is set by default (Alarms table - parameter 1055) to be active: Always.

The low fuel level sensor alarm can be associated with a debounce time (Alarms table - parameter 1056) during which the fuel level detected must be below the threshold setting (Thresholds table - parameter 318).

The low fuel level sensor alarm is set by default (Alarms table - parameter 1057) not to perform any action.

Short Circuit

The M7T control unit's short circuit alarm is associated with the RMS current measurement when any of the phases are above the maximum short circuit threshold setting (Thresholds table - parameter 308).

The phases that are checked to detect the overload alarm are selected according to the configuration of the installation phases (Configuration table - parameter 101):

1. In a single phase configuration phase 1 is tested.
2. In a two-phase configuration, phases 1 and 2 are tested.
3. In a three-phase configuration with neutral or three-phase without neutral phases 1, 2 and 3 are tested.

Detection of the short circuit alarm is set by default (Alarms table - parameter 1058) to be activated: From the rated condition of the engine.

The short circuit alarm is set by default (Alarms table - parameter 1060) to: Stop the engine with cooling of the engine.

Genset undervoltage threshold

The M7T control unit's minimum genset voltage alarm is associated with an RMS voltage measurement that drops below the minimum voltage threshold setting (Thresholds table - parameter 303).

The phases that are checked to detect the minimum genset voltage alarm are selected according to the configuration of the installation phases (Configuration table - parameter 101):

1. In a single phase configuration, phase 1 voltage is tested.
2. In a two-phase configuration, the voltages in phases 1 and 2 are tested.
3. In a three-phase configuration with neutral or three-phase without neutral, the voltages in phases 1, 2 and 3 are tested.

Detection of the genset minimum voltage alarm is set by default (Alarms table - parameter 1061) to be activated: From the rated condition of the engine.



A minimum genset voltage alarm can be associated with a debounce time (Alarms table - parameter 1062) during which the voltage must be kept below the minimum threshold setting (Thresholds table - parameter 303).

The minimum genset voltage alarm is set by default (Alarms table - parameter 1063) to stop the engine with cooling.

Genset underfrequency threshold

The M7T control unit's minimum genset frequency alarm is associated with a frequency generated by the genset that drops below the minimum frequency threshold setting (Thresholds table - parameter 306).

The measurement of genset frequency is carried out on the first phase. If in that phase no signal is detected, the frequency measurement is then carried out on the second phase. Likewise, if in that phase no signal is detected either, the frequency measurement is then carried out on the third phase.

Detection of the genset's minimum frequency alarm is set by default (Alarms table - parameter 1064) to be activated: From the rated condition of the engine.

The minimum genset frequency alarm can be associated with a debounce time (Alarms table - parameter 1065) during which the frequency must be kept below the minimum threshold setting (Thresholds table - parameter 306).

The minimum genset frequency alarm is set by default (Alarms table - parameter 1066) to stop the engine with cooling.

Unexpected stop

The M7T control unit's unexpected stop alarm is generated if all the running engine conditions are no longer detected (Configuration table - parameters 102 to 105) while the engine is running.

Stop failure

The M7T control unit's stop failure alarm is generated if 15 seconds have elapsed after stopping the engine and not all the stopped engine conditions are detected (Configuration table - parameters 102 to 105).

If the stop failure alarm has been disabled (Alarms table - parameter 1070), the control unit waits for a maximum of 15 seconds for stopped engine conditions before it considers that the engine is stopped.

Detection of a stopped engine requires all the stopped engine conditions to be detected for a set period of time (Alarms table - parameter 1071).

Unit signal failure

The M7T control unit's genset signal failure alarm is generated if no genset voltage is detected in any phase while the engine is running.

Detection of genset signal failure alarm is set by default (Alarms table - parameter 1076) to be activated: From the rated condition of the engine.

The genset signal failure alarm can be associated with a debounce time (Alarms table - parameter 1077) during which no signal must be detected in any phase before activating the alarm.

The genset signal failure alarm is set by default (Alarms table - parameter 1078) to stop the engine with cooling.

Programmable alarm 1

The M7T control unit's programmable alarm 1 is activated by associating the programmable alarm mode to either of the 2 general purpose inputs (ENT1 or ENT2) (Configuration table - parameters 120 and 121). The status of this input must be validated during a time interval (Times table - parameter 417) for stabilisation (debounce) before generating the programmable alarm 1 alarm.

Detection of the programmable alarm 1 is set by default (Alarms table - parameter 1079) to be activated: Never.

Programmable alarm 1 can be associated with a time (Alarms table - parameter 1080) to delay the moment when the alarm starts checking the alarm conditions.

Programmable alarm 1 is set by default (Alarms table - parameter 1081) to perform one of the following actions: Not perform any actions (warning).

Programmable alarm 2

The M7T control unit's programmable alarm 2 is activated by associating the programmable alarm mode to either of the general purpose inputs (ENT1 or ENT2) (Configuration table - parameters 120 and 121). The status of this input must be validated during a time interval (Times table - parameter 418) for stabilisation (debounce) before generating the programmable alarm 2 alarm.



Detection of the programmable alarm 2 is set by default (Alarms table - parameter 1082) to be activated: Never.

Programmable alarm 2 can be associated with a time (Alarms table - parameter 1083) to delay the moment when the alarm starts checking the alarm conditions.

Programmable alarm 2 is set by default (Alarms table - parameter 1084) to perform no action (warning).

Genset contactor failure

The M7T control unit's genset contactor alarm checks that the genset contactor is properly activated by using one of the general purpose digital inputs (ENT1 or ENT2) programmed for that purpose (Configuration table - parameters 120 and 121). Detection of the genset contactor alarm is set by default (Alarms table - parameter 1091) to be activated: Never.

The genset contactor alarm can be associated with a delay time to ensure proper activation of the genset contactor (Alarms table - parameter 1092). Likewise, the programmable input is configured with a filter stabilization time to guarantee that the signal is immune to electrical noise (Times table - parameters 417 and 418).

The genset contactor alarm is set by default (Alarms table - parameter 1093) to perform no action (warning).

Maintenance

The maintenance alarm is associated with the M7T control unit's maintenance counter. The alarm is activated when the M7T control unit detects that the hours of engine operation have exceeded the maintenance limit. The maintenance alarm is set to perform no action (warning).

The maintenance alarm cannot be notified by the user. The alarm is notified by reloading the control unit's maintenance counter or setting it back to zero (see Section 7.2).

Dead light bulb on lighting tower

The M7T dead light bulb alarm is activated if, after switching on the light bulb, the total consumption measured by the control unit through the current transformer does not increase by the expected amount (Measurements table, parameters 207 to 210). In order for the control panel to be able to identify which bulb has died it is necessary to use the lighting sequence.

After the detection of a dead light bulb, in addition to recording an entry in the alarm register, the control unit will display the dead light bulb icon corresponding to the output where it has been detected, even after the engine has been switched off. In order to stop it being displayed, you must turn off the control panel or replace the bulb and perform a switch on or switch off sequence in which the bulb is detected as working.

7. MAINTENANCE

7.1 OPERATION COUNTERS

The M7T control unit records various accumulated readings related to control unit operation. The counters that record the control unit are:

- **Total operating hours counter.** The control unit records the number of hours that the genset engine has been operating. The total operating hours counter is not resettable.
- **Correct start-ups counter.** The control unit counts the number of correct start-ups performed by the control unit. The correct starts counter can be reset to zero.
- **Failed start-ups counter.** The control unit counts the number of failed start-ups performed by the control unit. The failed start-ups counter can be reset to zero.
- **Total energy counter.** The control unit counts the total energy produced by the genset in kWh. The total energy counter is not resettable.

To display the value of the counters, it is necessary to access them from the Main Menu →3.Counters.

The partial counters can be reset to zero by selecting the arrow keys (▲ or ▼) and keeping the RESET key pressed for 5 seconds.

7.2 MAINTENANCE COUNTER

The M7T control unit has a programmable counter that is set to a certain time that decreases while the engine is detected as running. When the counter reaches zero, it triggers an alarm but does not stop the engine. The alarm disappears when the associated counter is reset.

Maintenance counter operation has the following options:

 **Programming.** The maintenance counter is programmed from the maintenance menu. By pressing the ✓ key, the different operating time values in hours are reset.



Display. The time remaining before programmed maintenance or the time elapsed since maintenance should have been performed, displayed in hours: minutes.

Mode	Format	Maintenance	Display
Fixed	--:--	Not programmed	Maintenance not programmed
Fixed	12:29 (hours: minutes)	Programmed	Time remaining for maintenance
Flashing	-12:10 (hours: minutes)	Programmed	Time elapsed since maintenance should have been performed

Notification. The maintenance alarm is notified and reset by pressing the ✓ key and entering the maintenance counter setting in hours.

Cancellation. To cancel the current maintenance counter, reset to 0 hours.



Fig.1
Time remaining to next maintenance (set)

7.3 LIST OF PREVIOUS ERRORS

The M7T control unit keeps a record of the detected alarms, saving the status of the control unit when they occurred.

The screen with the list of previous errors displays the last 100 errors recorded by the control unit. The details of all the control unit settings when the error occurred are stored for the last 10 errors.

7.4 PROGRAMMING ANALOGUE SENSORS CURVE

The M7T control unit has 3-curved programming by default for the temperature, pressure and fuel gauge sensors, programmed according to capsule types (the VDO 323-803-001-008 model for temperature, the VDO 360-081-030-009 model for pressure and the AST 0-330 Ohms model for the fuel gauge).

The M7T control unit's temperature and pressure sensor response curves can be programmed from the sensors' curve programming menu. The sensors' curve programming menu is accessed by keeping the ✓ key pressed for 5 seconds to access the administrator level password.

The following points should be taken into account to program the response curves of the temperature and pressure sensors:

1. There is a maximum of 32 points for each programmable curve.
2. With ohm values for the resistance value of the sensor curve. The resistance values of the sensor response curve must be entered in descending order, that is, the first point should correspond to the highest resistance value, the second point to the second highest resistance value, and so on. Only positive resistance values are permitted when programming the sensors curve points. When programming the gauge, the setting for the resistor is the value measured at the current moment.
3. The temperature values of the sensors curve points must be entered in degrees Celsius. Positive and negative temperature values are permitted when programming the sensors curve points.
4. The pressure values of the sensors curve points must be entered in kilopascals. Only positive pressure values are permitted when programming the sensors curve points.
5. The fuel gauge input settings are the % of the tank.
6. The pressure curve is applied to the oil pressure sensor.
7. As a special case, the pressure curve can be applied to the auxiliary sensor (oil temperature). In this case, the units of the programmed curve are interpreted as degrees Celsius (negative values are not allowed).

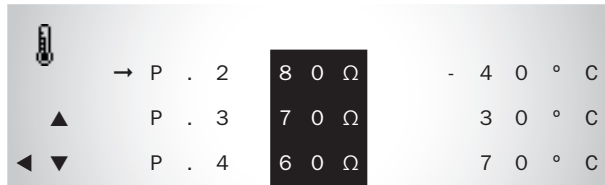

Fig.2

Resistance values in descending order

Table 1
Response curve for sensors

Point	Temperature		Pressure	
	VDO 323-803-001-008		VDO 360-081-030-009	
	Resistance Ω	Temperature °C	Resistance Ω	Pressure kPa
1	1716	-40	184	1000
2	9134	-30	170	900
3	6764	-25	163	850
4	5067	-20	156	800
5	3834	-15	140	700
6	2930	-10	124	600
7	2249	-5	107	500
8	1743	0	90	400
9	1364	5	71	300
10	1075	10	52	200
11	850	15	42	150
12	677	20	31	100
13	543	25	21	50
14	439	30	10	0
15	357	35	-	-
16	291	40	-	-
17	240	45	-	-
18	197	50	-	-
19	161	55	-	-
20	134	60	-	-
21	114	65	-	-
22	97	70	-	-
23	82	75	-	-
24	70	80	-	-
25	60	85	-	-
26	51	90	-	-
27	44	95	-	-
28	38	100	-	-
29	33	105	-	-
30	29	110	-	-
31	26	115	-	-
32	22	120	-	-

8. APPENDIX I: TABLE OF PARAMETERS

The M7T control unit allows 3 levels of access for settings. To modify any of the M7T control unit's parameters, validation is required by entering the corresponding password. The 3 levels of access are:

- 1. User.** Allows level 1 values to be read (default password: 1111).
- 2. Maintenance.** Allows level 1 and 2 values to be entered (default password: 1911).
- 3. Supervisor.** Allows level 1, 2 and 3 parameters to be entered (restricted for use by the manufacturer).

Table 1
Configuration table

Index	Psw	Description	Value	Range
101	2	Three-phase, two-phase, single phase or three-phase without neutral, delta or delta without neutral.	1	0- Three-phase without neutral 1- Three-phase 2- Two-phase 3- Single-phase 4- Delta 5- Delta without neutral 6- Two-phase selector
102	2	Phase voltage as start-up condition	3	
103	2	Alternator voltage as start-up condition	3	0- Condition not used 1- Genset start-up condition 2- Genset stop condition
104	2	Engine speed as start-up condition	3	3- Genset start-up and stop condition
105	2	BPA input as start-up condition	2	
106	2	Engine control settings	0	0- PD/PR 1- PE/PR 2- PD/PE 3- PR/PULL/HOLD
107	2	Voltage transformer	0	0- Not installed 1- Transformer 400/600
108	2	Ratio engine flywheel ring gear speed and unit voltage frequency	0	0 - 50 Hz/1500 rpm 60 Hz/1800 rpm 1 - 50 Hz/3000 rpm
109	2	Silent mode Control unit operating mode with silenced alarms and keypad	0	0- Silent mode inhibited 1- Silent mode active 2- Alarm inhibited during external start-up
110	3	Forced operation management	0	0- Not permitted 1- Free voltage contact start 2- Start-up due to forced operation



Index	Psw	Description	Value	Range
111	2	RC input polarity	1	
112	2	BPA input polarity	1	0- Disabled
113	2	ATA input polarity	1	1- Normally open
114	2	NA input polarity	1	2- Normally closed
115	2	PEM input polarity	2	
116	2	AE input polarity	1	
117	2	ENT1 input polarity	1	
118	2	ENT2 input polarity	1	
119	2	Motorpump mode Generator set management without electrical signal control (only engine control).	0	0- Generator set mode 1- engine pump mode
120	2	Programmable input 1 mode	0	0- None 1- Programmable alarm 1 2- Programmable alarm 2 3- Auxiliary configuration 4- Forced operation 5- Stop button 6- Generator contactor confirmation
121	2	Programmable input 2 mode	0	10- Inhibit Output 1 Lighting 11- Inhibit Output 2 Lighting 12- Inhibit Output 3 Lighting 13- Inhibit Output 4 Lighting 14- Inhibit All Outputs
122	2	Programmable output 1 mode (PD)	0	0- None 1- Electronic protection
123	2	Programmable output 2 mode (MC/MNA/MNC)	1	2- Dummy load 3- Fuel transfer pump 4- engine started
124	2	Programmable output 3 mode (CON)	5	5- Genset breaker 6- Input 1
125	2	Single transformer	0	0- One transformer per phase 1- One transformer per genset
126	2	RC input mode	0	0- None (default behaviour of input)
127	2	ATA input mode	0	1- Programmable alarm 1 2- Programmable alarm 2
128	2	BPA input mode	0	3- Auxiliary configuration 4- Forced operation
129	2	NA input mode	0	5- Stop button 6- Generator contactor confirmation
130	2	AE input mode	0	
131	2	Input P mode	0	10- Inhibit Output 1 Lighting 11- Inhibit Output 2 Lighting 12- Inhibit Output 3 Lighting
132	2	Input T mode	0	13- Inhibit Output 4 Lighting 14- Inhibit All Outputs

Table 2

Measurements table

Index	Psw	Description	Value	Range
201	2	Current transformer conversion factor - Factor common to RMS current values IR, IS, IT	100	
202	2	Fuel Level Regulation EMPTY in Ω		
203	2	Fuel Level Regulation FULL in Ω		
204	1	Units of pressure	0	0- bar 1- Psi
205	1	Units of temperature	0	0- Celsius 1- Fahrenheit
206	2	Programmable gauge enabling	0	0- Disabled 1- Enabled
207	2	Output 1 current	0	0..65535
208	2	Output 2 current	0	0..65535
209	2	Output 3 current	0	0..65535
210	2	Output 4 current	0	0..65535
211	5	Output current check error margin	20	0..100%
212	2	Minimum time between turning lights on simultaneously	5	0..3600 seconds

Table 3

Thresholds table

Index	Psw	Description	Value	Range
301	2	Number of Start-ups	4	1..10
302	2	Maximum Unit Voltage	440 V	
303	2	Minimum Unit Voltage	360 V	
305	2	Maximum Unit Frequency	55 Hz	
306	2	Minimum Unit Frequency	45 Hz	
307	2	Maximum generator current	1000 A	
308	2	Short circuit detection	3000 A	
311	2	Maximum engine speed	1650 rpm	
312	2	Minimum engine speed	1350 rpm	
313	2	Minimum battery voltage	8 V	8-23
314	2	Starting voltage in the genset signal	40 V	30-100
315	2	Starting voltage in the alternator	8 V	6-23



Index	Psw	Description	Value	Range
316	2	Engine start-up speed	1000 rpm	300-1000
317	2	Engine flywheel teeth	0	0-300
318	2	Low fuel level	10%	0..30
319	2	Low oil pressure threshold	1.2 bar	0.5 - 3 bar 7 - 43 psi
320	2	High water temperature threshold	98 °C	80-105 °C 175-220
326	2	Fuel transfer pump: Minimum fuel level	30%	15%-40%
327	2	Fuel transfer pump: Maximum fuel level	80%	20%-90%
328	2	Dummy load activation power	0 KW	0: Disabled 1...10000
329	2	Dummy load deactivation power	0 KW	0: Disabled 1...10000

Table 4
Times table

Index	Psw	Description	Value	Range
401	2	Time between Starts Period between start-ups during which all the outputs are disabled.	5"	3" ..15"
402	2	Spark Plugs Preheating Time	0"	0" ..180"
403	2	Startup Time Maximum waiting time before start-up has been achieved. During this period, the start-up output is active.	5"	1" ..30"
404	2	Charging Activation Time Time from the moment the start-up of the engine is detected until the activation of the genset contactor.	3"	1" ..600"
405	2	Rated condition time Time from the moment the start-up of the engine is detected until the quality of the signal generated begins to be validated.	2"	2" ..15"
406	2	D+ activation time At the end of this time, controls will begin to check the level of voltage supplied by the battery charging alternator.	3"	1" ..10"
407	2	Cooling Time Time that the engine remains in operation without load after the genset has been commanded to stop.	120"	0" ..1800"
408	2	PE activation time Activation time of the engine brake to stop the generator set with engine configuration type PR/PE and PD/PE.	10"	1" ..30"

Index	Psw	Description	Value	Range
409	2	Start Delay Time between external start-up and engine start. The alarm output remains active during this time.	0"	0" ..1800" (0 setting overlaps alarm output activation with engine start-up for 5 seconds)
410	2	Maximum alarm activation time. The alarm output is activated (together with the flashing of the reset and buzzer LED on the display) when appropriate during this time limit.	15"	0- Indefinite 1" ..1800"
411	2	Filtering of the RC input	1.0"	0.0" ..5.0"
412	2	Filtering of the BPA input	1.0"	0.0" ..5.0"
413	2	Filtering of the ATA input	1.0"	0.0" ..5.0"
414	2	Filtering of the NA input	1.0"	0.0" ..5.0"
415	2	Filtering of the PE input	0.2	0.0" ..5.0"
416	2	Filtering of the AE input	1.0"	0.0" ..5.0"
417	2	Filtering of the ENT1 input	1.0"	0.0" ..5.0"
418	2	Filtering of the ENT2 input	1.0"	0.0" ..5.0"
419	2	Mast rise time	0"	0" ..1000"
420	2	Output 1 switching on delay	4	0" ..3600"
421	2	Output 2 switching on delay	8	0" ..3600"
422	2	Output 3 switching on delay	12	0" ..3600"
423	2	Output 4 switching on delay	16	0" ..3600"
424	2	Output 1 shutdown delay	1	0" ..3600"
425	2	Output 2 shutdown delay	4	0" ..3600"
426	2	Output 3 shutdown delay	7	0" ..3600"
427	2	Output 4 shutdown delay	10	0" ..3600"
428	2	Cooling genset breaker switch off delay	12	0" ..3600"
429	2	Cooling time for output 1 reset	0	0" ..20000"
430	2	Cooling time for output 2 reset	0	0" ..20000"
431	2	Cooling time for output 3 reset	0	0" ..20000"
432	2	Cooling time for output 4 reset	0	0" ..20000"











Table 5
Parameter selection table

Parameter	Psw	Description	Value	Range
501	2	Signal type	1	0- Three-phase without neutral 1- Three-phase 2- Two-phase 3- Single-phase 4- Delta with neutral 5- Delta without neutral 6- Two-phase selector
502	2	Maximum Genset Voltage	440 V	
503	2	Minimum Genset Voltage	360 V	
504	2	Maximum generator current	1000 A	
505	2	Short circuit detection	3000 A	
506	2	Genset maximum frequency/speed	58	Motor pump mode ¹ : maximum engine speed in rpm Genset mode ¹ : maximum genset frequency in Hz
507	2	Genset minimum frequency/speed	45	In motor pump mode ¹ : minimum engine speed in rpm In Genset mode ¹ : minimum genset frequency in Hz
508	3	Engine speed	0	0-65535
509	2	Fine adjustment of speed	125	0-250: Fine adjustment of engine speed









¹ Configuration table - parameter 119.







Table 6
Alarms table

Parameter	Psw	Description	Default value	Range
1001	3	 Management alarm 1 High Water Temperature	1	0- Not checked 1- Always checked 2- When starting 3- From rated condition (In operation) 4- From start condition (Stabilised)
1002	3	Delay alarm 1	0"	0"...5"
1003	3	Mode alarm 1	1	0- Doesn't stop engine 1- Stops engine 2- Stops engine with cooling
1004	3	 Management alarm 2 Low oil pressure	4	0..4



Parameter	Psw	Description	Default value	Range
1005	3	Delay alarm 2	15"	0"...30"
1006	3	Mode alarm 2	1	0..2
1007	-	 Management alarm 3 Emergency stop	1	Read only
1008	-	Filter alarm 3	0"	Read only
1009	-	Mode alarm 3	1	Read only
1010	2	 Management alarm 4 Battery Alternator failure	3	0..4
1011	2	Filter alarm 4	5"	0"...30"
1012	2	Mode alarm 4	0	0..2
1013	2	 Management alarm 5 Engine start-up failure	1	Read only
1014	2	Filter alarm 5	5"	0"...30"
1015	-	Mode alarm 5	0	Read only 0..2
1016	3	 Management alarm 6 Low Water Level	1	0..4
1017	3	Delay alarm 6	5"	0"...30"
1018	3	Mode alarm 6	1	0..2
1019	2	 Management alarm 7 Fuel Reserve	1	0..4
1020	2	Delay alarm 7	5"	0"...30"
1021	2	Mode alarm 7	0	0..2
1022	2	 Management alarm 8 Overspeed	4	0..4
1023	2	Filter alarm 8	5"	0"...30"
1024	2	Mode alarm 8	1	0..2
1025	2	 Management alarm 9 Underspeed	4	0..4
1026	2	Filter alarm 9	15"	0"...30"
1027	2	Mode alarm 9	2	0..2



Parameter	Psw	Description	Default value	Range
1028	2	 Management alarm 10 Overload	4	0..4
1029	2	Filter alarm 10	15	0"..."30"
1030	2	Mode alarm 10	2	0..2
1034	2	 Management alarm 12 Genset overvoltage threshold	3	0..4
1035	2	Filter alarm 12	5"	0"..."30"
1036	2	Mode alarm 12	1	0..2
1037	2	 Management alarm 13 Genset overfrequency threshold	4	0..4
1038	2	Filter alarm 13	1"	0"..."30"
1039	2	Mode alarm 13	1	0..2
1046	2	 Management alarm 16 Low battery voltage	1	0..4
1047	2	Filter alarm 16	15	0"..."30"
1048	2	Mode alarm 16	0	0..2
1049	2	 Management alarm 16 High Water Temperature (by sensor)	1	0..4
1050	2	Filter alarm 16	5"	0"..."30"
1051	2	Mode alarm 16	0	0..2
1052	2	 Management alarm 17 Low oil pressure (by sensor)	3	0..4
1053	2	Filter alarm 17	5"	0"..."30"
1054	2	Mode alarm 17	0	0..2
1055	2	 Management alarm 19 Low fuel level (by sensor)	1	0..1
1056	2	Filter alarm 19	5"	0"..."30"
1057	2	Mode alarm 19	0	0..2
1058	2	 Management alarm 20 Short-circuit	4	0..4

Parameter	Psw	Description	Default value	Range
1059	-	Filter alarm 20	0	Read only 0"..."30"
1060	2	Mode alarm 20	2	0..2
1061	2	 Management alarm 21 Genset undervoltage threshold	3	0..4
1062	2	Filter alarm 21	15"	0"..."30"
1063	2	Mode alarm 21	2	0..2
1064	2	 Management alarm 22 Genset underfrequency threshold	3	0..4
1065	2	Filter alarm 22	15"	0"..."30"
1066	2	Mode alarm 22	2	0..2
1067	-	 Management alarm 23 Unexpected engine stop	4	Read only
1068	-	Filter alarm 23	5"	Read only
1069	-	Mode alarm 23	0	Read only
1070	2	 Management alarm 24 Stop failure	1	0..1
1071	2	Filter alarm 24	3"	0"..."30"
1072	-	Mode alarm 24	1	
1076	2	 Management alarm 26 Genset signal failure	3	0..4
1077	2	Filter alarm 26	2"	0"..."30"
1078	2	Mode alarm 26	2	0..2
1079	2	 Management alarm 27 Programmable alarm 1	0	0..4
1080	2	Filter alarm 27	0'	0"..."30"
1081	2	Mode alarm 27	0	0..2
1082	2	 Management alarm 28 Programmable alarm 2	0	0..4
1083	2	Filter alarm 28	0'	0"..."30"
1084	2	Mode alarm 28	0	0..2



Parameter	Psw	Description	Default value	Range
1091	2	 Management alarm 31 Genset contactor failure	0	0..4
1092	2	Filter alarm 31	0'	0"...30"
1093	2	Mode alarm 31	0	0..2
1094	2	 Management alarm 32 Dead light bulb on lighting tower	4	0..4
1095	2	Filter alarm 32	1'	0"...30"
1096	2	Mode alarm 32	0	0..2



9. APPENDIX II: SCREENS OF THE M7T CONTROL UNIT

9.1 CONTROL UNIT STATUS

The status of the M7T control unit is shown on the display, allowing access to different display options using the up and down navigation keys.

9.1.1 GENERATOR MEASUREMENT SCREENS

1. Measurements of voltage between the various phases and neutral, the phase currents and frequency.



Fig.1
Genset frequency



Fig.2
Phase-neutral voltage



Fig.3
Phase currents



2. Measurements of voltage between phases, currents each phase and frequency.

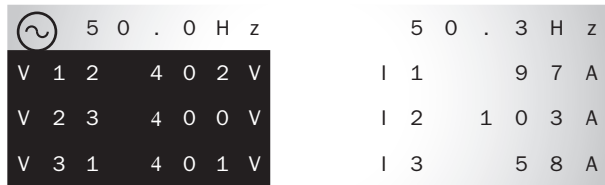

Fig.4
Phase-to-phase voltage

3. Measurements of the generator set/engine. The measurements of voltage and current are shown cyclically by phases.



Fig.5
Frequency

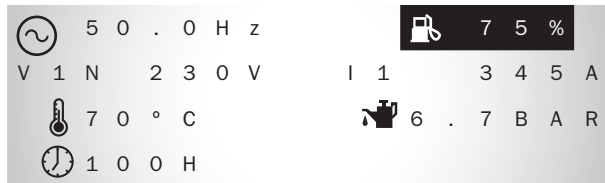

Fig.6
Fuel level (only with gauge installed)



Fig.7
Voltages and currents

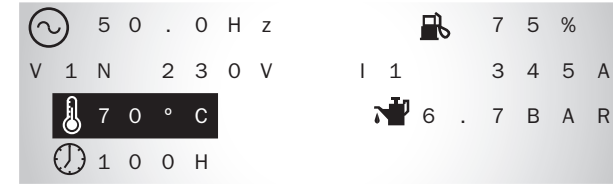

Fig.8
Engine coolant temperature (in Celsius or Fahrenheit - Measurements table - parameter 205-)



Fig.9
Hours of operation



Fig.10
Oil pressure (in bar or psi -Measurements table - parameter 204-)



9.1.2 ENGINE STATUS SCREEN

4. Engine operation parameter measurements. The operation parameters measured in the engine are displayed, depending on which sensors have been installed:







	Engine speed display (in rpm)
	Hours of operation (in hours)
	Fuel tank level (in %)
	Battery charging alternator voltage (in volts)
	Engine temperature (in Celsius or Fahrenheit Measurements table - parameter 205)
	Battery voltage (in volts)
	Oil pressure (in bar or psi -Measurements table - parameter 204-)



Fig.1
Engine speed

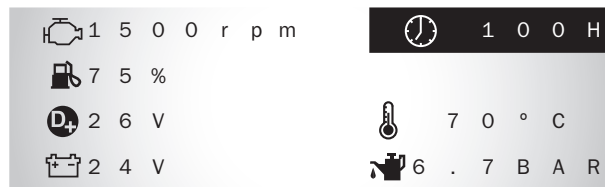

Fig.2
Hours of operation

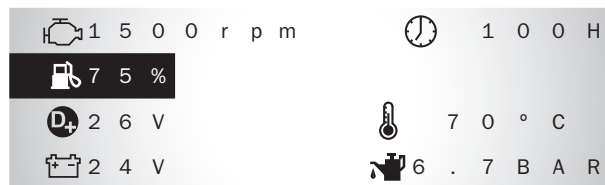

Fig.3
Fuel level (only with gauge installed)

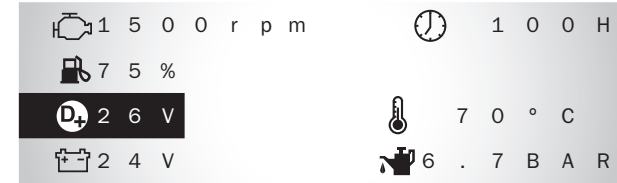

Fig.4
Battery charging alternator voltage



Fig.5
Battery voltage

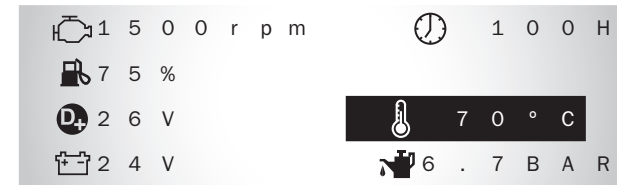

Fig.6
Engine coolant temperature (in Celsius or Fahrenheit - Measurements table - parameter 205-)



Fig.7
Oil pressure (in bar or psi -Measurements table - parameter 204-)

NOTE

To display the engine temperature and oil pressure, the engine must be provided with appropriate sensors. If the J1939 expansion is enabled, the chart that is shown is . Electronic engine regulation activation is indicated in the engine chart.



9.1.3 CONTROL UNIT STATUS SCREEN

5. Status of the programmable inputs.

The screen displays the following sections:

- EXTERNAL START-UP INPUT STATUS**
 - LT Open
 - LT Closed
- MOTOR PUMP STATUS**
 - Preheating (remaining time is displayed)
 - Starting
 - Started
 - Started and stabilized
 - Cooling (remaining time is displayed)
 - 5:12
- GENSET CONTACTOR STATUS**
 - Contactor open
 - Contactor closed
- USB connection

The control unit's status screen displays the status of the lighting tower outputs with the following icons:

	Active output
	Inactive output discounting cooling time
	Fault detected at the output
	Inactive output

On the right of the display, on the same line as the output icons, a timer shows the time until the next output status change.

9.1.4 POWER AND ENERGY SCREEN

NOTE

Displayed on the energy screen are both accumulated energy as well as the date and time, if the option of a timer is installed in the control unit.

6.- Measurements of actual power and cos phi per phase.



Fig.1
POWER:
Active (kW)
Apparent (kVA)
Reactive (kVAR)



Fig.2
cosφ: Total power factor /
φ1: Power factor phase 1
φ2: Power factor phase 2
φ3: Power factor phase 3



9.1.5 LIST OF ERRORS



Fig.1

ERRORS SCREEN:

Flashing: an error with engine stop (alarm) / Steady: all errors without engine stop (warning).



Fig.2

Moving the arrow keys up and down: errors listed on more than 1 page (more than 8 errors detected/displayed on the page)



Fig.3

STATUS OF THE ALARMS: Flashing: active error / Steady: error pending notification

	Enters error screen. Notifies inactive errors; if no errors are active after notification, it returns to the main screen.
	Exits alarm list screen
	Goes to the following page in the list of alarms (only if there are more than 8 errors in the list).

9.2 CONTROL UNIT MAINTENANCE

9.2.1 PASSWORD ENTRY

The password entered remains active up to 10 minutes after the detection of the last password.











	From the main menu: enter the validation screen From the validation screen: accept value
	Go back a digit/screen.
	Change a digit.



9.2.2 MAIN MENU

The main menu screen gives access to the different menus, to enter each menu select it with the cursor keys and validate the selection. The current menu selection appears in flashing mode.









	Maintenance: <ul style="list-style-type: none"> • digital inputs • digital outputs • analogue inputs
	Parameters (only with authorization key)
	Counters
	List of previous errors
	Customizing passwords
	Schedules (only in control units with an expansion timer)
	Date/time adjustment (only in control units with an expansion timer)
	Engine diagnosis









9.2.3 MAINTENANCE

Digital inputs and outputs

The first screen of the maintenance menu displays the statuses of the digital inputs and outputs.

	Engine start-up
	Preheating
	Engine (PD:enable / PE:stop)
	Alarm active
	Genset contactor
	Battery alternator excitation
	Programmable output 1



	Fuel reserve
	Low oil pressure
	High temperature
	Water level
	External start-up
	Emergency stop
	Programmable input 1
	Programmable input 2



Analogue inputs

The second screen of the maintenance menu displays the resistance values of the analogue inputs. If a sensor is not connected, the field assigned to the analogue input is not displayed. Likewise, if the M7T control unit has the temperature control expansion, control unit temperature is displayed in ° Celsius.

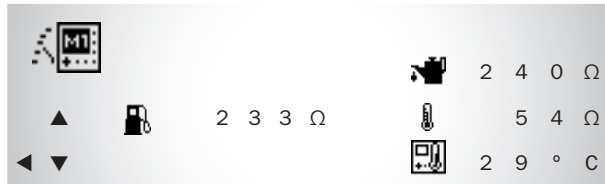

	Value in Ω of the fuel level analogue input
	Value in Ω of the oil pressure analogue input
	Value in Ω of the engine temperature analogue input
	Control unit temperature (optional)

9.2.4 COUNTERS

The counters screen is used to access the various control unit operation data records.



	Total engine running time counter (hours:minutes)
	Correct engine start-ups counter
	Engine failed start-up attempts counter
	Maintenance counter
	Total genset generated energy counter (kWh)

9.2.5 LIST OF PREVIOUS ERRORS

The screen with the list of previous errors displays the last 100 errors recorded by the control unit. The details of all the control unit settings when the error occurred are stored for the last 10 errors. The selected error is displayed in flashing mode; its position in the list and its error code are shown on the screen.



Fig.1
Selected error code



Fig.2
Selected error position / Number of errors in the list

The details of the control unit status when the error occurred can be displayed for any of the 10 most recent errors (shown at the beginning of the list) by pressing . The screen icon changes to when an error with control unit details is selected.

9.2.6 SCHEDULED EVENTS (ONLY EXPANSION TIMER)

Schedules can only be programmed in the M7T control unit if the expansion timer is installed (M7R). The scheduling is carried out via the fifth option of the maintenance menu .

The schedules are programmed to be repeated periodically one day a week. To access each day of the week in the menu, select an option (flashing mode) with the arrow keys and validate by pressing .

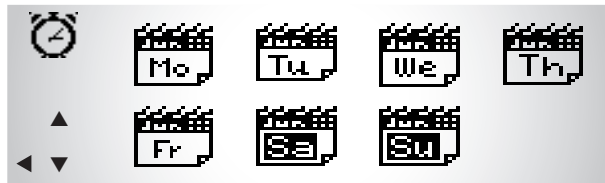

Possible actions that can be scheduled are (in order of priority):

- **locked** (): prevents the genset from starting and inhibits the activation of the counter.
- **forced start-up** (): starts the genset and activates the contactor.
- **test** (): starts the genset without activating the contactor; in the event of receiving an external start-up command.
- **free** (---): no action is scheduled for that range; the start time and end time have no effect.

The Timer option allows up to 5 different actions to be programmed on the same day. For each option its activation range is defined indicating the hour and minute of the start-up and end; the start-up time must always be before the end. The start-up time and end time are between 00:00 and 23:59.

Choose a day of the week and validate by pressing . Use the arrow and validation keys to program conditions, start hours and minutes and stop hours and minutes. To select programming 2-3-4-5, use the arrow keys and repeat the previous process.

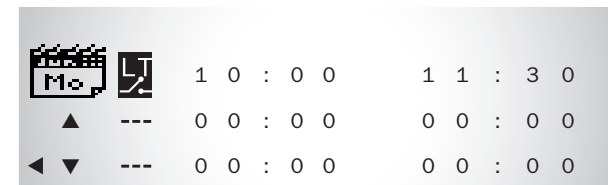

Fig.1
Type of action

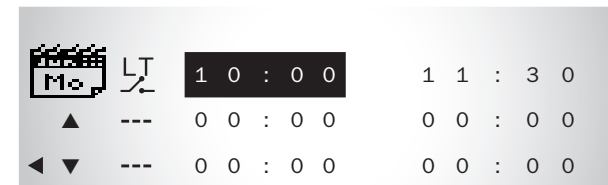

Fig.2
Start time

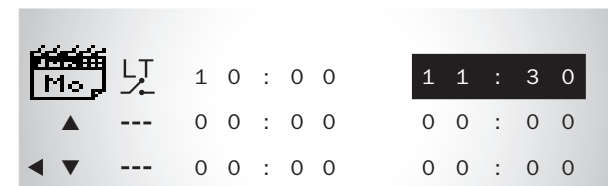

Fig.3
End time

NOTE

If you wish to program an action with an operating range that covers 2 consecutive days of the week (e.g. Monday between 22:00 and 03:00 on Tuesday), program the action to end at 23:59 on Monday and the same action to start up at 00:00 on Tuesday.



9.2.7 DATE AND TIME (M7R)

The arrow and validation keys can be used to adjust the date and time in the control unit from the maintenance menu.



Fig.1
Selection

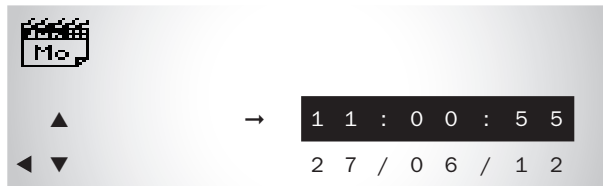

Fig.2
Hour



Fig.3
Date (dd/mm/yy)

9.3 CONFIGURATION

9.3.1 CUSTOMIZING PASSWORDS

The passwords programmed in the control unit can be changed from the password customization screen. Users **only** have permissions to change the passwords that belong to their access level or lower.



Password levels:

 User

 Maintenance

 Programming



Fig.1
Old password



Fig.2
New password



9.3.2 CONTROL UNIT PROGRAMMING

To enter each menu select it with the arrow keys and the validation key. The main menu is restricted to a minimum of a maintenance level password.

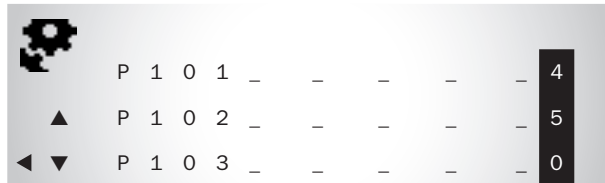
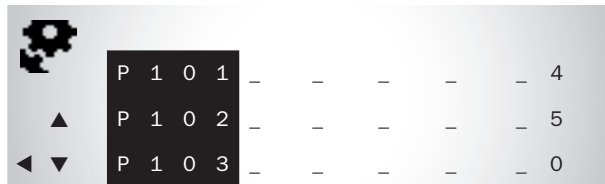
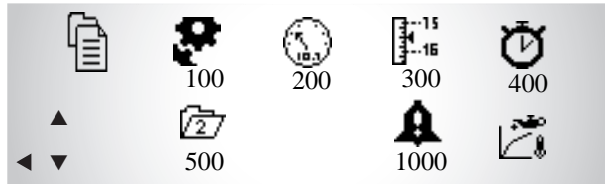

Fig.1
Parameter No.

Fig.1
Value

Parameter tables:

	Control unit general setup parameters
	Measurement parameters
	Threshold parameters
	Time parameters
	Alarm parameters
	Second set parameters
	Sensor curves

9.3.3 PROGRAMMING SENSOR CURVES

The sensor curve parameter menu is used to program the 3 response curves that can be applied to the temperature, pressure and fuel gauge sensors (Measurements table - parameter 206).



Programming the response curves of the sensors is carried out by entering decreasing resistance value points. For curve 1 associated with temperature sensors, positive and negative values temperature are permitted; for curve 2 associated with pressure sensors only positive pressure values are permitted. The data for curve 3, which corresponds to the fuel gauge, are entered by the position of the fuel gauge. The maximum number of points for the temperature and pressure curves is 32 per curve and 8 for the fuel gauge.

The arrow keys are used to select each new point and enter the resistance value; the values range from 0 to the resistance value of the previous point. After entering the resistance value, the accept key is pressed and the value associated with said resistance is entered. To finish programming the curve, hold down the validation key for 5 seconds after entering the value for the physical units of the point; to program a new point on the curve, press the validation key.

Once programming the curve has been completed, the system automatically returns to the sensors menu.

10. APPENDIX III: DIMENSIONS, WIRING AND MECHANICAL PARTS

10.1 M7T CONTROL UNIT

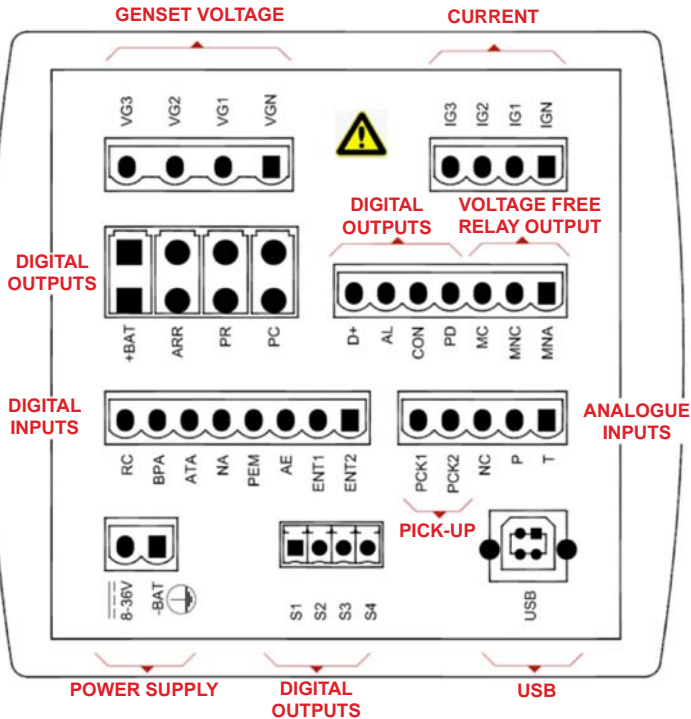

Fig.1
M7T control unit



10.2 INSTALLATION AND WIRING

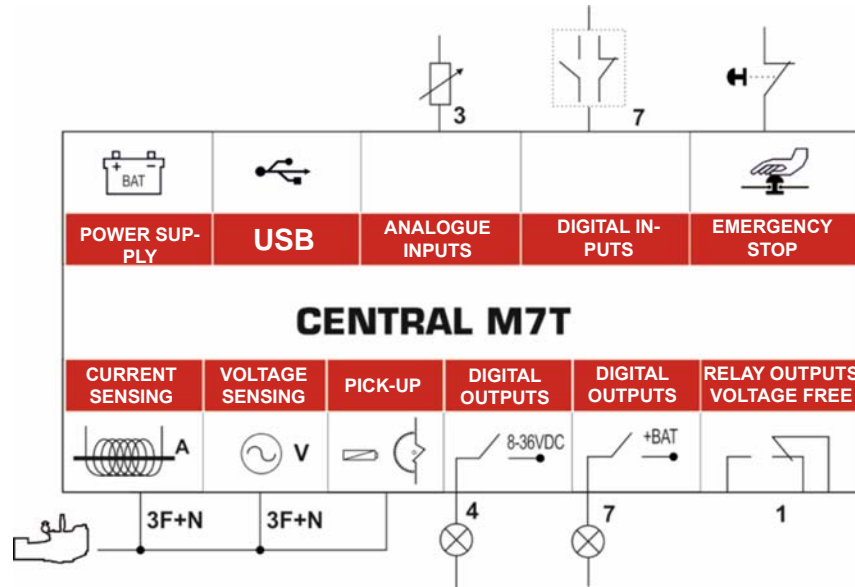

Fig.2
M7T Control Unit Connections

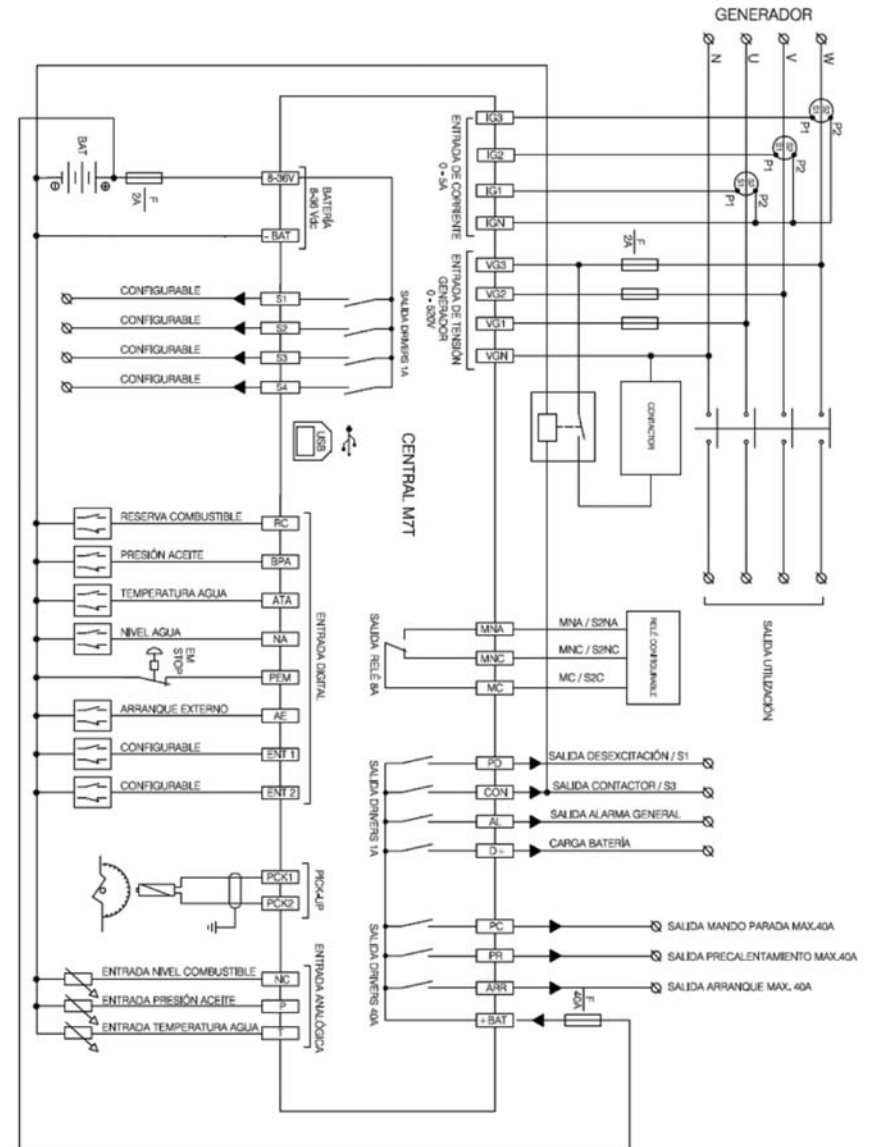

Fig.3
M7T Control Unit wiring diagram



Table 1
M7T Control Unit Connections

Signal	Description	Type	Characteristics
POWER SUPPLY			
8+36 V	Positive battery terminal	Power supply	Module supply voltage from 8 to 36 V
-BAT	Negative battery terminal	Power supply	Module supply negative
PNP OUTPUTS			
S1	Output 1	Output	PNP digital output
S2	Output 2	Output	PNP digital output
S3	Output 3	Output	PNP digital output
S4	Output 4	Output	PNP digital output
DIGITAL INPUTS			
RC	Fuel reserve	Input	NPN digital input
BPA	Low oil pressure	Input	NPN digital input
ATA	High water temperature	Input	NPN digital input
NA	Water level	Input	NPN digital input
PEM	Emergency Stop	Input	NPN digital input
AE	External start-up	Input	NPN digital input
ENT1	Input 1	Input	NPN digital input
ENT2	Input 2	Input	NPN digital input
PICK-UP INPUT			
PCK1	Pick-up input	Input	PICK-UP input
PCK2	Pick-up input	Input	PICK-UP input
ANALOGUE INPUTS			
NC	Fuel level	Input	Analogue input of resistance sensor VDO
P	Oil pressure	Input	Analogue input of resistance sensor VDO
T	Coolant temperature	Input	Analogue input of resistance sensor VDO
HIGH VOLTAGE PNP OUTPUTS			
+BAT	Positive battery terminal	Power supply	Digital outputs supply voltage
ARR	Start-up	Output	PNP digital output of power
PR	Preheating	Output	PNP digital output of power
PC	Configurable stop	Output	PNP digital output of power

Signal	Description	Type	Characteristics
PNP OUTPUTS			
D+	Alternator excitation	Output	PNP digital output
AL	Alarm	Output	PNP digital output
CON	Contact / S3	Output	PNP digital output
PD	Ignition / S1	Output	PNP digital output
VOLTAGE FREE RELAY OUTPUT			
MC	C / S2C contact	Output	Voltage free relay output, C contact
MNC	NC / S2NC contact	Output	Voltage free relay output, NC contact
MNA	NA / S2NA contact	Output	Voltage free relay output, NA contact
GENSET THREE-PHASE CURRENT INPUTS			
IGN	Neutral current	Input	Analogue input for current measurement
IG1	R-phase current	Input	Analogue input for current measurement
IG2	S-phase current	Input	Analogue input for current measurement
IG3	T-phase current	Input	Analogue input for current measurement
GENSET THREE-PHASE VOLTAGE INPUT			
VGN	Neutral	Input	Analogue input for voltage measurement
VG1	R-phase voltage	Input	Analogue input for voltage measurement
VG2	S-phase voltage	Input	Analogue input for voltage measurement
VG3	T-phase voltage	Input	Analogue input for voltage measurement

The USB connector complies with the standard 2.0.

To power the control unit, it is recommended that a cable be used with a cross-section of 1 mm².

The equipment must be isolated or disconnected before connecting the voltage input for the generator, as there is a risk of danger.

A cable with a cross-section of 2.5 mm² must be used for +BAT, ARR, PR and PC connections. For the rest of the connections it is recommended that a cable be used with a cross-section of 1 mm².

The control unit must be mounted at the front of an electrical panel, if possible in the centre to allow easy wiring. There are no special ventilation requirements due to the low power consumed by the control unit.

The surface areas of the equipment and the external face should be cleaned with a damp cloth. The equipment is included within the measurement category CAT III 600 V for measurements performed in the building installation.



Disconnection means should be incorporated to the fixed installation in accordance with installation regulations. Such means must have contact separation for all poles that provide full disconnection in category III overvoltage conditions.

The disconnecting means must be accessible by the user. The negative terminal of the battery, the chassis of the electrical panel and the chassis of the generator set must all be earthed.



This equipment can generate the risk of danger if handled improperly. It must be installed by qualified personnel. It is necessary to consult the equipment's documentation.

ATTENTION: risk of danger.

10.3 ELECTRICAL CHARACTERISTICS

Symbol	Parameter	Conditions	Minimum	Typical	Maximum	Unit
Power supply (terminals 8÷36V, -BAT, +BAT)						
8÷36 V	Module supply voltage		8		36	VDC
+BAT	Power supply of the outputs		8		36	VDC
I_{BAT}	Supply current	8÷36 V = 12 V			80	mA
I_{BAT}	Supply current	8÷36 V = 24 V			40	mA
P_{BAT}	Power consumption				1	W
PNP outputs (S1, S2, S3, S4 terminals)						
V_o	Output voltage		8		36	VDC
I_o	Output current				1	A
NPN digital inputs (terminals RC, BPA, ATA, NA, PEM, AE, ENT1, ENT2)						
V_{IN}	Input voltage		-0.7		40	V
V_{IL}	Low level input voltage				1	V
V_{IH}	High level input voltage		5			V
I_{IL}	Low level input current	$V_{IN} = 0 V$		2	2.5	mA
I_{IH}	High level input current	$V_{IN} = 24 V$		0	100	uA
PICK-UP sensor input (PCK terminals)						
V_{IN}	Input voltage				30	VAC
I_{IN}	Input current	$V_{IN} = 12 VAC$		2.6	3	mA
F_{IN}	Input frequency	$V_{IN} = 12 VAC$		3600		Hz

Symbol	Parameter	Conditions	Minimum	Typical	Maximum	Unit
Analogue inputs (terminals NC, P, T)						
V_i	Input voltage				5	V
R_{NC}	Fuel level resistance		0		400	Ω
R_p	Pressure resistance		0		200	Ω
R_T	Water temperature resistance		0		4000	Ω
R_{TC}	Oil temperature resistance		0		4000	Ω
D_i	Alternator voltage		0		40	V
PNP high current outputs (terminals PC, PR, ARR)						
V_o	Output voltage			+BAT		V
I_o	Output current	$T = \infty$			20	A
I_o	Output current	$T = 1 s$			40	A
PNP outputs (terminals D+, AL, PD, CON)						
V_o	Output voltage			+BAT		V
I_o	Output current				1	A
R_{D+}	Output resistance D+				47	Ω
Relay outputs (terminals MC, MNC, MNA)						
V_o	High voltage relay contacts				250	VAC
I_o	Current relay contacts	$\cos\phi = 1$			8	A
Current measurement analogue inputs (terminals IGN, IG1, IG2, IG3)						
I_{IN}	Input current				5	AAC
R_{IN}	Input resistance				0.05	Ω
Voltage measurement analogue inputs (terminals VGN, VG1, VG2, VG3)						
V_{INFF}	Input voltage phase to phase				520	VAC
V_{INFN}	Input voltage phase to neutral				300	VAC
Environmental conditions and protection of the enclosure						
Temp.	Operating temperature		-20		+70	$^{\circ}C$
H_R	Relative humidity	No condensation			80	%
	IP Degree of Protection	*see note 1			65	

Note 1: IP 65 on the front of the control unit when installed on the control panel with the sealing gasket provided.

The equipment has been designed and manufactured according to the requirements of the directives and harmonized standards which are applicable for compliance with EC regulations.



10.4 DIMENSIONS

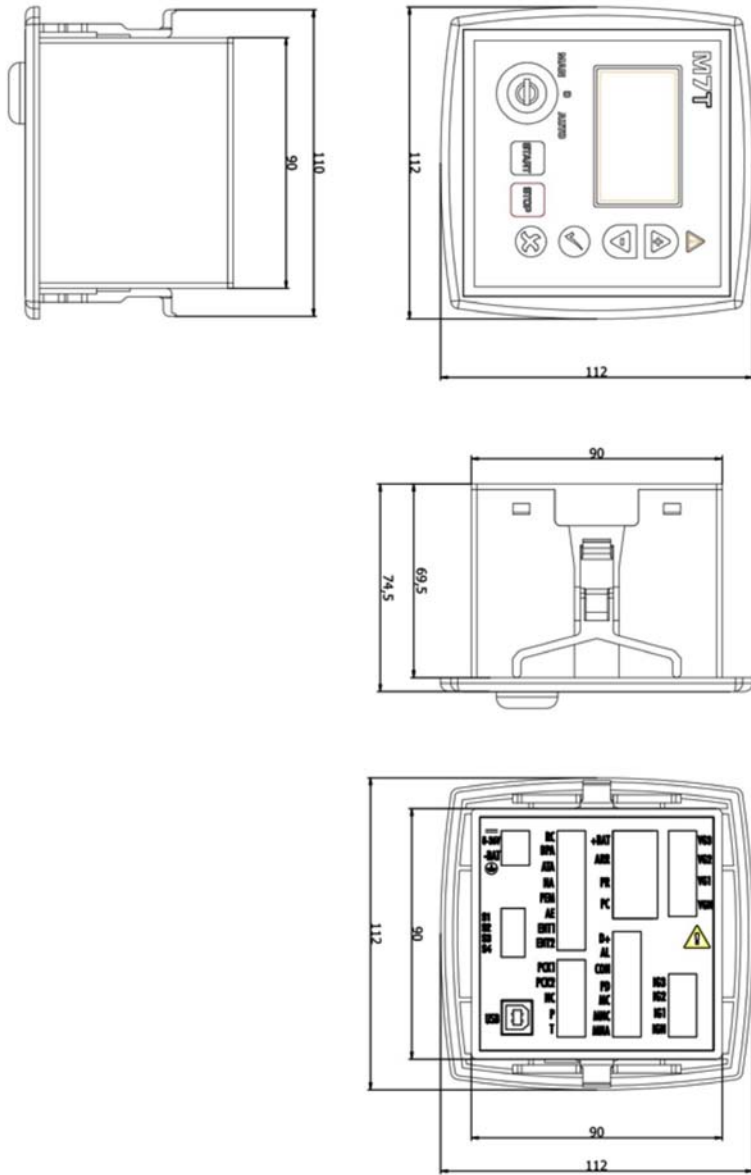

Fig.2
M7T Control Unit dimensions





FACTORIES

SPAIN • FRANCE • INDIA • CHINA • USA • BRAZIL • ARGENTINA

SUBSIDIARIES

PORTUGAL | SINGAPORE | POLAND | UAE | PANAMA | GERMANY
ARGENTINA | ANGOLA | UNITED KINGDOM | DOMINICAN REPUBLIC | SOUTH AFRICA

HEADQUARTERS

Ctra. Murcia - San Javier, km 23.6
30730 SAN JAVIER (Murcia) SPAIN
Tel.: +34 968 19 11 28 | +34 902 19 11 28
Fax: +34 968 19 12 17 | Fax - Exports: +34 968 33 43 03

www.himoinsa.com

Himoinsa reserves the right to change any feature without prior notice.
The illustrations may include optional equipment and/or accessories.
Not contractual images. The technical indications described in this manual correspond to the information available at the moment of printing.
HIMOINSA © - 2017 © All rights reserved.



HIMOINSA